

**650ns Precision Sample and Hold Amplifier**

The HA-5330 is a very fast sample and hold amplifier designed primarily for use with high speed A/D converters. It utilizes the Intersil Dielectric Isolation process to achieve a 650ns acquisition time to 12-bit accuracy and a droop rate of 0.01 $\mu$ V/ $\mu$ s. The circuit consists of an input transconductance amplifier capable of producing large amounts of charging current, a low leakage analog switch, and an integrating output stage which includes a 90pF hold capacitor.

The analog switch operates into a virtual ground, so charge injection on the hold capacitor is constant and independent of  $V_{IN}$ . Charge injection is held to a low value by compensation circuits and, if necessary, the resulting 0.5mV hold step error can be adjusted to zero via the Offset Adjust terminals. Compensation is also used to minimize leakage currents which cause voltage droop in the Hold mode.

The HA-5330 will operate at reduced supply voltages (to  $\pm 10V$ ) with a reduced signal range. The MIL-STD-883 data sheet for this device is available on request.

**Ordering Information**

PART NUMBER	TEMP. RANGE (°C)	PACKAGE	PKG. NO.
HA1-5330-2	-55 to 125	14 Ld CERDIP	F14.3
HA1-5330-5	0 to 75	14 Ld CERDIP	F14.3
HA3-5330-5	0 to 75	14 Ld PDIP	E14.3

**Pinout**

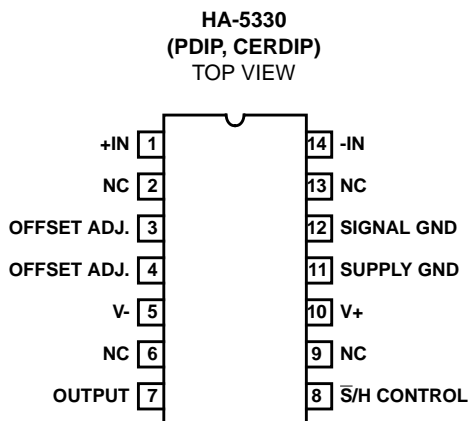

**Features**

- Very Fast Acquisition . . . . . 500ns (0.1%) 650ns (0.01%)
- Low Droop Rate . . . . . 0.01 $\mu$ V/ $\mu$ s
- Very Low Offset . . . . . 0.2mV
- High Slew Rate. . . . . 90V/ $\mu$ s
- Wide Supply Range . . . . .  $\pm 10V$  to  $\pm 20V$
- Internal Hold Capacitor
- Fully Differential Input
- TTL/CMOS Compatible

**Applications**

- Precision Data Acquisition Systems
- D/A Converter Deglitching
- Auto-Zero Circuits
- Peak Detectors

**Functional Diagram**

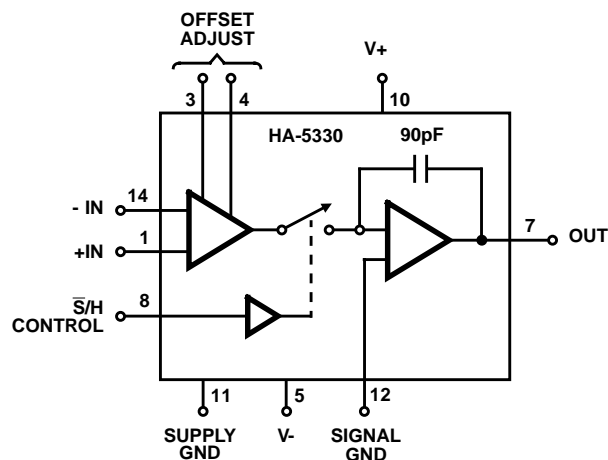

**Absolute Maximum Ratings**

Voltage between V+ and SUPPLY/SIG GND . . . . . +20V  
 Voltage between V- and SUPPLY/SIG GND . . . . . -20V  
 Voltage between SUPPLY GND and SIG GND . . . . . ±2.0V  
 Voltage between  $\bar{S}/H$  Control and SUPPLY/SIG GND . . . . +8V, -6V  
 Differential Input Voltage . . . . . 24V  
 Output Current, Continuous (Note 1) . . . . . ±17mA

**Thermal Information**

Thermal Resistance (Typical, Note 3)  $\theta_{JA}$  (°C/W)  $\theta_{JC}$  (°C/W)  
 CERDIP Package . . . . . 66 16  
 PDIP Package . . . . . 90 N/A  
 Maximum Junction Temperature (Ceramic Package, Note 2) . . . 175°C  
 Maximum Junction Temperature (Plastic Package) . . . . . 150°C  
 Maximum Storage Temperature Range . . . . . -65°C to 150°C  
 Maximum Lead Temperature (Soldering 10s) . . . . . 300°C

**Operating Conditions**

Temperature Range  
 HA-5330-2 . . . . . -55°C to 125°C  
 HA-5330-5 . . . . . 0°C to 75°C  
 Supply Voltage Range (Typical) . . . . . ±10V to ±20V

*CAUTION: Stresses above those listed in "Absolute Maximum Ratings" may cause permanent damage to the device. This is a stress only rating and operation of the device at these or any other conditions above those indicated in the operational sections of this specification is not implied.*

**NOTES:**

1. Internal Power Dissipation may limit Output Current below ±17mA.
2. Maximum power dissipation, including output load, must be designed to maintain the junction temperature below 175°C for the ceramic package, and below 150°C for the plastic package.
3.  $\theta_{JA}$  is measured with the component mounted on an evaluation PC board in free air.

**Electrical Specifications**  $V_{SUPPLY} = \pm 15V$ ;  $\bar{S}/H$  Control  $V_{IL} = +0.8V$  (Sample);  $V_{IH} = +2.0V$  (Hold); SIG GND = SUPPLY GND, Unity Gain Configuration (Output tied to -Input), Unless Otherwise Specified

PARAMETER	TEST CONDITIONS	TEMP. (°C)	HA-5330-2			HA-5330-5			UNITS
			MIN	TYP	MAX	MIN	TYP	MAX	
<b>INPUT CHARACTERISTICS</b>									
Input Voltage Range		Full	±10	-	-	±10	-	-	V
Input Resistance (Note 4)		25	5	15	-	5	15	-	MΩ
Input Capacitance		25	-	3	-	-	3	-	pF
Offset Voltage		25	-	0.2	-	-	0.2	-	mV
		Full	-	-	2.0	-	-	1.5	mV
Offset Voltage Temperature Coefficient		Full	-	1	10	-	1	10	μV/°C
Bias Current		25	-	±20	-	-	±20	-	nA
		Full	-	-	±500	-	-	±300	nA
Offset Current		25	-	20	-	-	20	-	nA
		Full	-	-	500	-	-	300	nA
Common Mode Range		Full	±10	-	-	±10	-	-	V
CMRR	$V_{CM} = \pm 10V$	Full	86	100	-	86	100	-	dB
<b>TRANSFER CHARACTERISTICS</b>									
Gain	DC	Full	$2 \times 10^6$	$2 \times 10^7$	-	$2 \times 10^6$	$2 \times 10^7$	-	V/V
Gain Bandwidth Product	Note 12	25	-	4.5	-	-	4.5	-	MHz
<b>OUTPUT CHARACTERISTICS</b>									
Output Voltage		Full	±10	-	-	±10	-	-	V
Output Current		Full	±10	-	-	±10	-	-	mA
Full Power Bandwidth (Note 6)		25	-	1.4	-	-	1.4	-	MHz
Output Resistance	Hold Mode	25	-	0.2	-	-	0.2	-	Ω
	Sample Mode	25	-	$10^{-5}$	0.001	-	$10^{-5}$	0.001	Ω

## HA-5330

**Electrical Specifications**  $V_{SUPPLY} = \pm 15V$ ;  $\bar{S}/H$  Control  $V_{IL} = +0.8V$  (Sample);  $V_{IH} = +2.0V$  (Hold); SIG GND = SUPPLY GND, Unity Gain Configuration (Output tied to -Input), Unless Otherwise Specified **(Continued)**

PARAMETER	TEST CONDITIONS	TEMP. (°C)	HA-5330-2			HA-5330-5			UNITS
			MIN	TYP	MAX	MIN	TYP	MAX	
Total Output Noise, DC to 4MHz	Sample Mode		-	230	-	-	230	-	$\mu V_{RMS}$
	Hold Mode	25	-	190	-	-	190	-	$\mu V_{RMS}$
<b>TRANSIENT RESPONSE</b>									
Rise Time	Note 5	25	-	70	-	-	70	-	ns
Overshoot	Note 5	25	-	10	-	-	10	-	%
Slew Rate	Note 7	25	-	90	-	-	90	-	V/ $\mu s$
<b>DIGITAL INPUT CHARACTERISTICS</b>									
Input Voltage	$V_{IH}$	Full	2.0	-	-	2.0	-	-	V
	$V_{IL}$	Full	-	-	0.8	-	-	0.8	V
Input Current	$V_{IL} = 0V$	Full	-	10	40	-	10	40	$\mu A$
	$V_{IH} = 5V$	Full	-	10	40	-	10	40	$\mu A$
<b>SAMPLE/HOLD CHARACTERISTICS</b>									
Acquisition Time	To 0.1%, Note 8	25	-	500	-	-	500	-	ns
		Full	-	-	700	-	-	700	ns
	To 0.01%, Note 8	25	-	650	-	-	650	-	ns
		Full	-	-	900	-	-	900	ns
Aperture Time (Note 4)		25	-	20	-	-	20	-	ns
Effective Aperture Delay Time		25	-50	-25	0	-50	-25	0	ns
Aperture Uncertainty		25	-	0.1	-	-	0.1	-	ns
Droop Rate (Note 9)		25	-	0.01	-	-	0.01	-	$\mu V/\mu s$
		Full	-	-	100	-	-	10	$\mu V/\mu s$
Hold Step Error	Note 10	25	-	0.5	-	-	0.5	-	mV
Hold Mode Settling Time	To 0.01%	25	-	100	200	-	100	200	ns
Hold Mode Feedthrough	20V <sub>p-p</sub> , 100kHz	Full	-	-88	-	-	-88	-	dB
<b>POWER SUPPLY CHARACTERISTICS</b>									
Positive Supply Current		Full	-	18	22	-	18	24	mA
Negative Supply Current		Full	-	19	23	-	19	25	mA
Power Supply Rejection	Note 11	Full	86	100	-	86	100	-	dB

**NOTES:**

4. Derived from computer simulation only; not tested.
5.  $V_I = 200mV$  Step;  $R_L = 2k\Omega$ ;  $C_L = 50pF$ .
6. Full power bandwidth based on slew rate measurement using:  $FPBW = \frac{Slew\ Rate}{2\pi V_{PEAK}}$ . Distortion of wave shape occurs beyond 100kHz due to slew rate enhancement circuitry.
7.  $V_O = 20V$  Step;  $R_L = 2k\Omega$ ;  $C_L = 50pF$ .
8.  $V_O = 10V$  Step;  $R_L = 2k\Omega$ ;  $C_L = 50pF$ .
9. This parameter is measured at ambient temperature extremes in a high speed test environment. Consequently, steady state heating effects from internal power dissipation are not included.
10.  $V_{IN} = 0V$ ;  $V_{IH} = +3.5V$ ;  $t_R = 22ns$  ( $V_{IL}$  to  $V_{IH}$ ). See graph.
11. Based on a 3V delta in each supply, i.e.  $15V \pm 1.5V_{DC}$ .
12.  $V_{OUT} = 200mV_{p-p}$ ,  $R_L = 2k\Omega$ ,  $C_L = 50pF$ .

### Application Information

The HA-5330 has the uncommitted differential inputs of an op amp, allowing the Sample/Hold function to be combined with many conventional op amp circuit ideas. See the Intersil Application Note AN517 for a collection of circuit ideas.

#### Layout

A printed circuit board with ground plane is recommended for best performance. Bypass capacitors (0.01 $\mu$ F to 0.1 $\mu$ F, ceramic) should be provided from each power supply terminal to the Supply GND Terminal on pin 11.

### Typical Applications

The HA-5330 is configured as a unity gain noninverting amplifier by simply connecting the output (pin 7) to the inverting input (pin 14). As an input device for a fast successive - approximation A/D converter, it offers an extremely high throughput rate. Also, the HA-5330's pedestal error is adjustable to zero by using an Offset Adjust potentiometer (10K to 50K) center tapped to V-

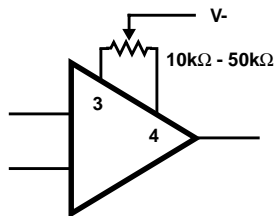

FIGURE 1. HA-5330 OFFSET ADJUST

The ideal ground connections are pin 11 (Supply Ground) directly to the system Supply Common, and pin 12 (Signal Ground) directly to the system Signal Ground (Analog Ground).

#### Hold Capacitor

The HA-5330 includes a 90pF MOS hold capacitor, sufficient for most high speed applications (the Electrical Specifications section is based on the internal capacitor).

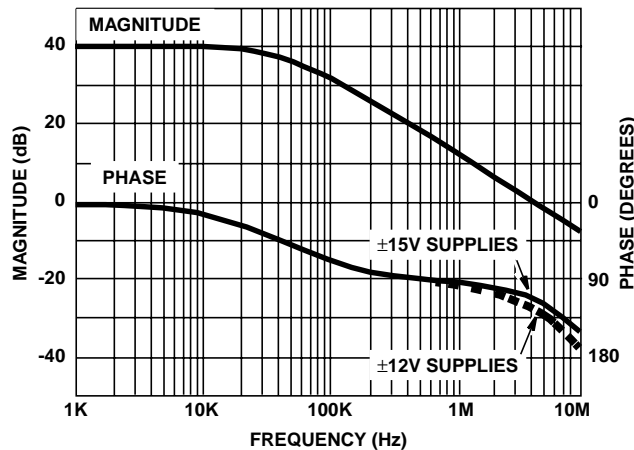

FIGURE 2. MAGNITUDE AND PHASE RESPONSE (CLOSED LOOP GAIN = 100)

### Output Stage

The HA-5330 output circuit does not include short circuit protection, and consequently its output impedance remains low at high frequencies. Thus, the step changes in load current which occur during an A/D conversion are absorbed at the  $\bar{S}/H$  output with minimum voltage error. A momentary short circuit to ground is permissible, but the output is not designed to tolerate a short of indefinite duration.

### Glossary of Terms

#### Acquisition Time

The time required following a "sample" command, for the output to reach its final value within  $\pm 0.1\%$  or  $\pm 0.01\%$ . This is the minimum sample time required to obtain a given accuracy, and includes switch delay time, slewing time and settling time.

#### Aperture Time

The time required for the sample-and-hold switch to open, independent of delays through the switch driver and input amplifier circuitry. The switch opening time is that interval between the conditions of 10% open and 90% open.

#### Hold Step Error

Hold step error is the output shift due to charge transfer from the sample to the hold mode. It is also referred to as "offset step" or "pedestal error".

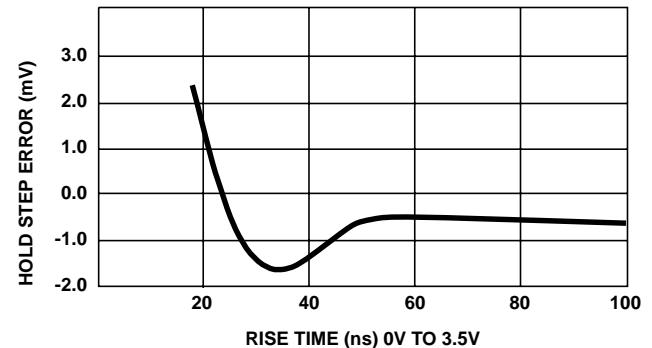

FIGURE 3. HOLD STEP ERROR vs  $\bar{S}/H$  CONTROL RISE TIME

#### Effective Aperture Delay Time (EADT)

The difference between the digital delay time from the Hold command to the opening of the  $\bar{S}/H$  switch, and the propagation time from the analog input to the switch.

EADT may be positive, negative or zero. If zero, the  $\bar{S}/H$  amplifier will output a voltage equal to  $V_{IN}$  at the instant the Hold command was received. For negative EADT, the output in Hold (exclusive of pedestal and droop errors) will correspond to a value of  $V_{IN}$  that occurred before the Hold command.

#### Aperture Uncertainty

The range of variation in Effective Aperture Delay Time. Aperture Uncertainty (also called Aperture Delay Uncertainty, Aperture Time Jitter, etc.) sets a limit on the accuracy with which a waveform can be reconstructed from sample data.

## Die Characteristics

### DIE DIMENSIONS:

99 mils x 166 mils x 19 mils  
 2510 $\mu$ m x 4210 $\mu$ m x 483 $\mu$ m

### METALLIZATION:

Type: Al, 1% Cu  
 Thickness: 16k $\text{Å}$   $\pm$  2k $\text{Å}$

### PASSIVATION:

Type: Nitride ( $\text{Si}_3\text{N}_4$ ) over Silox ( $\text{SiO}_2$ , 5% Phos.)  
 Silox Thickness: 12k $\text{Å}$   $\pm$  2k $\text{Å}$   
 Nitride Thickness: 3.5k $\text{Å}$   $\pm$  1.5k $\text{Å}$

### SUBSTRATE POTENTIAL (Powered Up):

Signal GND

### TRANSISTOR COUNT:

205

### PROCESS:

Bipolar Dielectric Isolation

## Metallization Mask Layout

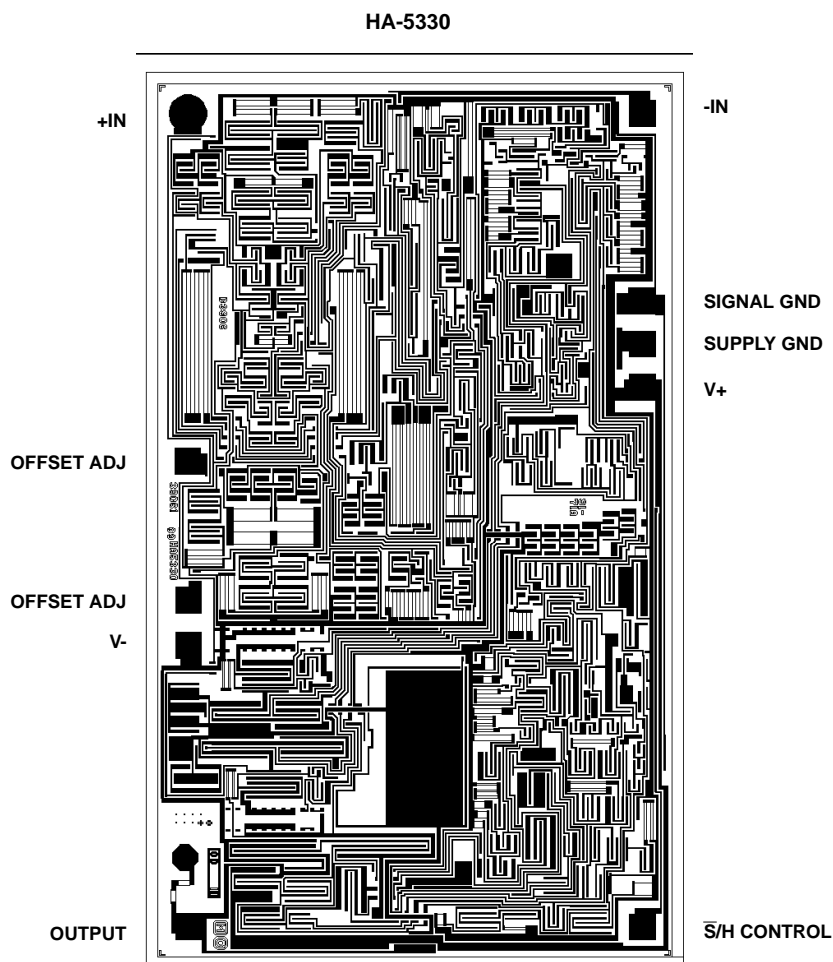

All Intersil semiconductor products are manufactured, assembled and tested under **ISO9000** quality systems certification.

*Intersil semiconductor products are sold by description only. Intersil Corporation reserves the right to make changes in circuit design and/or specifications at any time without notice. Accordingly, the reader is cautioned to verify that data sheets are current before placing orders. Information furnished by Intersil is believed to be accurate and reliable. However, no responsibility is assumed by Intersil or its subsidiaries for its use; nor for any infringements of patents or other rights of third parties which may result from its use. No license is granted by implication or otherwise under any patent or patent rights of Intersil or its subsidiaries.*

For information regarding Intersil Corporation and its products, see web site <http://www.intersil.com>

This datasheet has been downloaded from:

[www.DatasheetCatalog.com](http://www.DatasheetCatalog.com)

Datasheets for electronic components.



LittleDiode supplies new, hard to find or obsolete electronic components and semiconductors all over the world.

With over two million different components listed you are sure to find the part you need.

Feel free to visit us today at our online store:

**[LittleDiode.com](http://LittleDiode.com)**

Looking forward to providing you with the best possible service.