HM62256B Series

256k SRAM (32-kword × 8-bit)

HITACHI

ADE-203-135F (Z)

Rev. 6.0

Nov. 13, 1997

Description

The Hitachi HM62256B Series is a CMOS static RAM organized 32,768-word × 8-bit. It realizes higher performance and low power consumption by employing 0.8 μm Hi-CMOS process technology. The device, packaged in 8 × 14 mm TSOP, 8 × 13.4 mm TSOP with thickness of 1.2 mm, 450 mil SOP (foot print pitch width), 600 mil plastic DIP, or 300 mil plastic DIP, is available for high density mounting. It offers low power standby power dissipation; therefore, it is suitable for battery backup systems.

Features

- Single 5.0 V supply: 5.0 V ± 10%
- Access time: 55 ns/70 ns/85 ns (max)
- Power dissipation:
 - Active: 25 mW (typ) (f = 1 MHz)
 - Standby: 1.0 μW (typ)
- Completely static memory
 - No clock or timing strobe required
- Equal access and cycle times
- Common data input and output
 - Three state output
- Directly TTL compatible all inputs and outputs
- Battery backup operation

HM62256B Series

Ordering Information

Type No.	Access time	Package
HM62256BLP-7	70 ns	600-mil 28-pin plastic DIP (DP-28)
HM62256BLP-7SL	70 ns	
HM62256BLSP-7	70 ns	300-mil 28-pin plastic DIP (DP-28NA)
HM62256BLSP-7SL	70 ns	
HM62256BLFP-7T	70 ns	450-mil 28-pin plastic SOP (FP-28DA)
HM62256BLFP-5SLT	55 ns	
HM62256BLFP-7SLT	70 ns	
HM62256BLFP-7ULT	70 ns	
HM62256BLT-8	85 ns	8 mm × 14 mm 32-pin TSOP (TFP-32DA)
HM62256BLT-7SL	70 ns	
HM62256BLTM-8	85 ns	8 mm × 13.4 mm 28-pin TSOP (TFP-28DA)
HM62256BLTM-5SL	55 ns	
HM62256BLTM-7SL	70 ns	
HM62256BLTM-7UL	70 ns	

Pin Arrangement

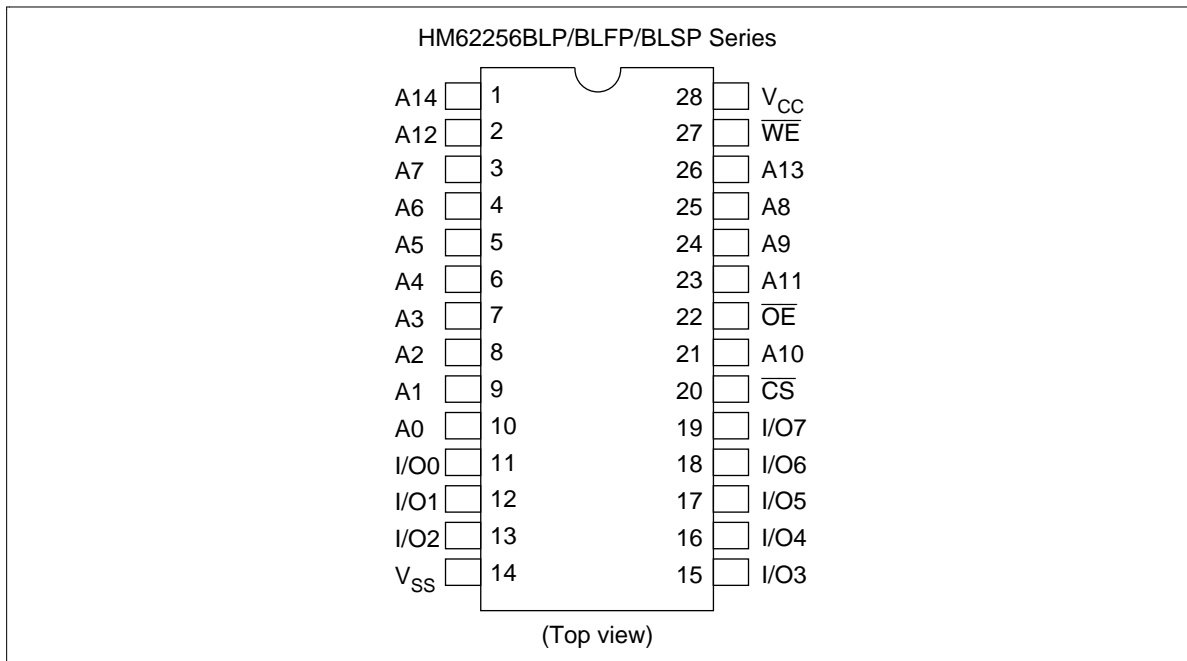

Pin Arrangement (cont.)

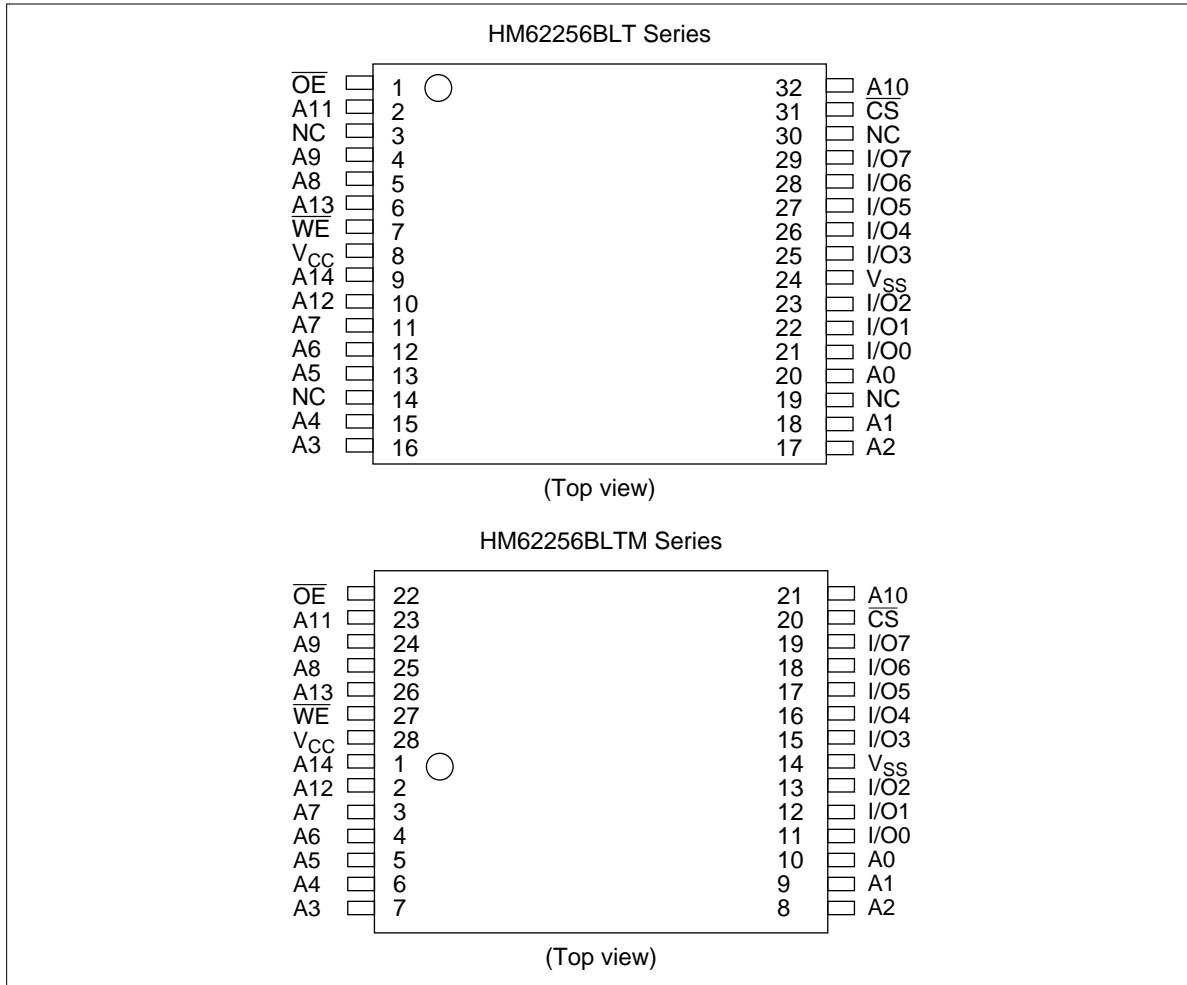

Pin Description

Pin Name	Function
A0 to A14	Address input
I/O0 to I/O7	Data input/output
\overline{CS}	Chip select
\overline{WE}	Write enable
\overline{OE}	Output enable
V _{CC}	Power supply
V _{SS}	Ground
NC	No connection

HM62256B Series

Block Diagram

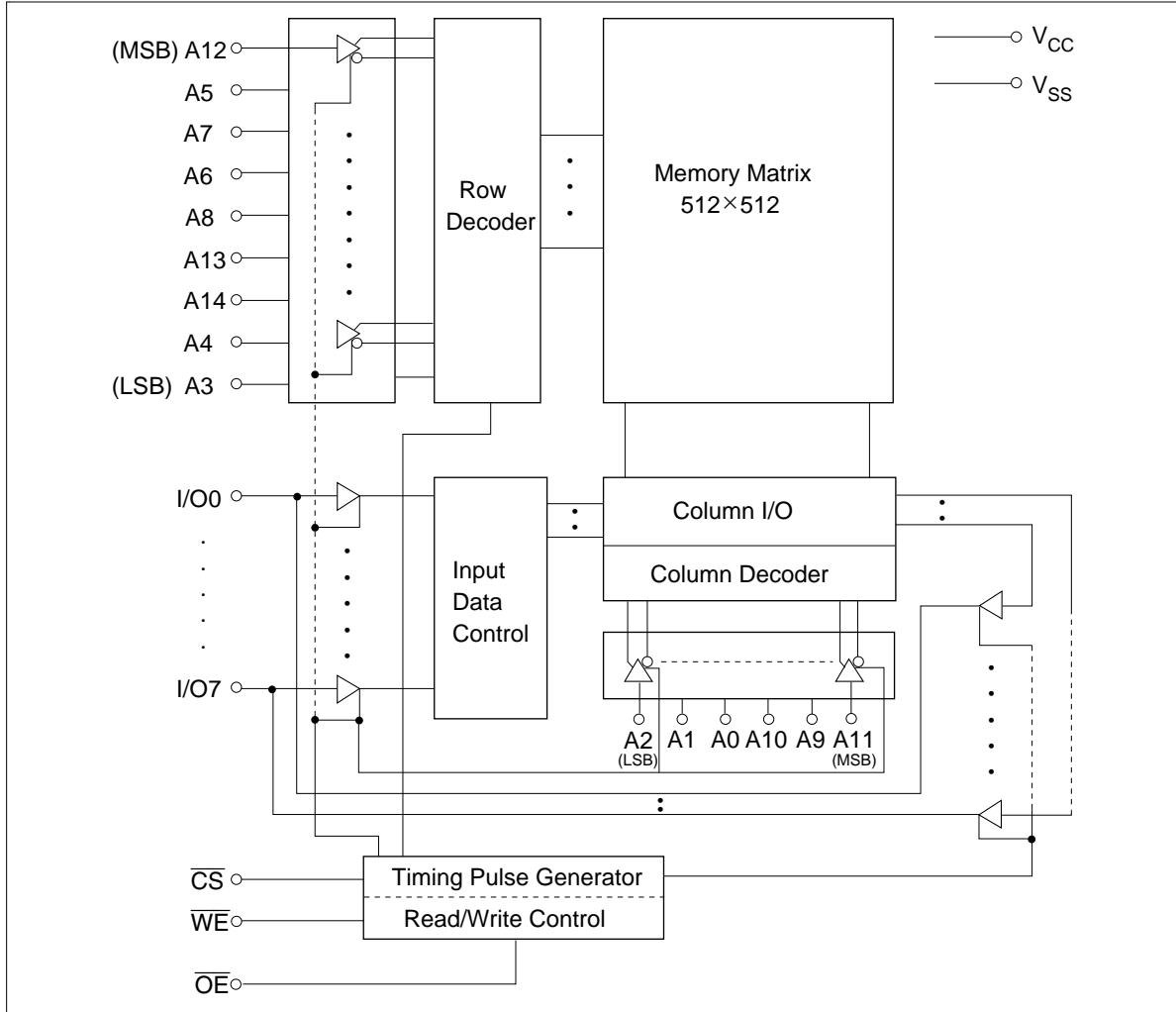

Operation Table

\overline{WE}	\overline{CS}	\overline{OE}	Mode	V_{CC} current	I/O pin	Ref. cycle
×	H	×	Standby	I_{SB}, I_{SB1}	High-Z	—
H	L	H	Output disable	I_{CC}	High-Z	—
H	L	L	Read	I_{CC}	Dout	Read cycle (1)to (3)
L	L	H	Write	I_{CC}	Din	Write cycle (1)
L	L	L	Write	I_{CC}	Din	Write cycle (2)

Note: ×: H or L

Absolute Maximum Ratings

Parameter	Symbol	Value	Unit
Power supply voltage relative to V_{SS}	V_{CC}	-0.5 to +7.0	V
Terminal voltage on any pin relative to V_{SS}	V_T	-0.5* ¹ to $V_{CC}+0.3$ * ²	V
Power dissipation	P_T	1.0	W
Operating temperature range	T_{opr}	0 to +70	°C
Storage temperature range	T_{stg}	-55 to +125	°C
Storage temperature range under bias	T_{bias}	-10 to +85	°C

Notes: 1. V_T min: -3.0 V for pulse half-width \leq 50 ns
 2. Maximum voltage is 7.0 V

DC Operating Conditions ($T_a = 0$ to +70°C)

Parameter	Symbol	Min	Typ	Max	Unit	Notes
Supply voltage	V_{CC}	4.5	5.0	5.5	V	
	V_{SS}	0	0	0	V	
Input high voltage	V_{IH}	2.2	—	$V_{CC} + 0.3$	V	
Input low voltage	V_{IL}	-0.5* ¹	—	0.8	V	

Note: 1. V_{IL} min: -3.0 V for pulse half-width \leq 50 ns

HM62256B Series

DC Characteristics ($T_a = 0$ to $+70^\circ\text{C}$, $V_{CC} = 5\text{ V} \pm 10\%$, $V_{SS} = 0\text{ V}$)

Parameter	Symbol	Min	Typ* ¹	Max	Unit	Test conditions	
Input leakage current	$ I_{LI} $	—	—	1	μA	$V_{in} = V_{SS}$ to V_{CC}	
Output leakage current	$ I_{LO} $	—	—	1	μA	$\overline{CS} = V_{IH}$ or $\overline{OE} = V_{IH}$ or $\overline{WE} = V_{IL}$, $V_{IO} = V_{SS}$ to V_{CC}	
Operating current	I_{CC}	—	6	15	mA	$\overline{CS} = V_{IL}$, Others = V_{IH}/V_{IL} , $I_{IO} = 0\text{ mA}$	
Average operating current	HM62256B-5	I_{CC1}	—	—	60	mA	Min cycle, duty = 100%, $I_{IO} = 0\text{ mA}$, $\overline{CS} = V_{IL}$, Others = V_{IH}/V_{IL}
	HM62256B-7	I_{CC1}	—	33	60	mA	
	HM62256B-8	I_{CC1}	—	29	50	mA	
		I_{CC2}	—	5	15	mA	Cycle time = 1 μs , $I_{IO} = 0\text{ mA}$, $\overline{CS} = V_{IL}$, $V_{IH} = V_{CC}$, $V_{IL} = 0$
Standby current	I_{SB}	—	0.3	2	mA	$\overline{CS} = V_{IH}$	
	I_{SB1}	—	0.2	100	μA	$V_{in} \geq 0\text{ V}$, $\overline{CS} \geq V_{CC} - 0.2\text{ V}$	
	I_{SB1}	—	0.2^{*2}	50^{*2}	μA		
	I_{SB1}	—	0.2^{*3}	10^{*3}	μA		
Output low voltage	V_{OL}	—	—	0.4	V	$I_{OL} = 2.1\text{ mA}$	
Output high voltage	V_{OH}	2.4	—	—	V	$I_{OH} = -1.0\text{ mA}$	

Notes: 1. Typical values are at $V_{CC} = 5.0\text{ V}$, $T_a = +25^\circ\text{C}$ and not guaranteed.

2. This characteristic is guaranteed only for L-SL version.

3. This characteristic is guaranteed only for L-UL version.

Capacitance ($T_a = 25^\circ\text{C}$, $f = 1.0\text{ MHz}$)

Parameter	Symbol	Min	Typ	Max	Unit	Test Conditions
Input capacitance* ¹	C_{in}	—	—	8	pF	$V_{in} = 0\text{ V}$
Input/output capacitance* ¹	C_{IO}	—	—	10	pF	$V_{IO} = 0\text{ V}$

Note: 1. This parameter is sampled and not 100% tested.

AC Characteristics ($T_a = 0$ to $+70^\circ\text{C}$, $V_{CC} = 5.0\text{ V} \pm 10\%$)

Test Conditions

- Input pulse levels: 0.8 V to 2.4 V
- Input rise and fall time: 5 ns
- Input and output timing reference levels: 1.5 V
- Output load: 1 TTL Gate + C_L (50 pF) (HM62256B-5)
 1 TTL Gate + C_L (100 pF) (HM62256B-7/8)
 (Including scope & jig)

Read Cycle

Parameter	Symbol	HM62256B						Unit	Notes
		-5		-7		-8			
		Min	Max	Min	Max	Min	Max		
Read cycle time	t_{RC}	55	—	70	—	85	—	ns	
Address access time	t_{AA}	—	55	—	70	—	85	ns	
Chip select to access time	t_{ACS}	—	55	—	70	—	85	ns	
Output enable to output valid	t_{OE}	—	35	—	40	—	45	ns	
Chip select to output in low-Z	t_{CLZ}	5	—	10	—	10	—	ns	2
Output enable to output in low-Z	t_{OLZ}	5	—	5	—	5	—	ns	2
Chip deselect to output in high-Z	t_{CHZ}	0	20	0	25	0	30	ns	1, 2
Output disable to output in high-Z	t_{OHZ}	0	20	0	25	0	30	ns	1, 2
Output hold from address change	t_{OH}	5	—	5	—	5	—	ns	

HM62256B Series

Write Cycle

Parameter	Symbol	HM62256B						Unit	Notes
		-5		-7		-8			
		Min	Max	Min	Max	Min	Max		
Write cycle time	t_{WC}	55	—	70	—	85	—	ns	
Chip selection to end of write	t_{CW}	40	—	60	—	75	—	ns	5
Address setup time	t_{AS}	0	—	0	—	0	—	ns	6
Address valid to end of write	t_{AW}	40	—	60	—	75	—	ns	
Write pulse width	t_{WP}	35	—	50	—	55	—	ns	4, 13
Write recovery time	t_{WR}	0	—	0	—	0	—	ns	7
Write to output in high-Z	t_{WHZ}	0	20	0	25	0	30	ns	1, 2, 8
Data to write time overlap	t_{DW}	25	—	30	—	35	—	ns	
Data hold from write time	t_{DH}	0	—	0	—	0	—	ns	
Output active from end of write	t_{OW}	5	—	5	—	5	—	ns	2
Output disable to output in High-Z	t_{OHZ}	0	20	0	25	0	30	ns	1, 2, 8

Notes: 1. t_{CHZ} , t_{OHZ} and t_{WHZ} are defined as the time at which the outputs achieve the open circuit conditions and are not referred to output voltage levels.

2. This parameter is sampled and not 100% tested.
3. Address must be valid prior to or simultaneously with \overline{CS} going low.
4. A write occurs during the overlap of a low \overline{CS} and a low \overline{WE} . A write begins at the latest transition of \overline{CS} going low or \overline{WE} going low. A write ends at the earliest transition of \overline{CS} going high or \overline{WE} going high. t_{WP} is measured from the beginning of write to the end of write.
5. t_{CW} is measured from \overline{CS} going low to the end of write.
6. t_{AS} is measured from the address valid to the beginning of write.
7. t_{WR} is measured from the earliest of \overline{CS} or \overline{WE} going high to the end of write cycle.
8. During this period, I/O pins are in the output state; therefore, the input signals of the opposite phase to the outputs must not be applied.
9. If \overline{CS} goes low simultaneously with \overline{WE} going low or after \overline{WE} going low, the outputs remain in the high impedance state.
10. Dout is the same phase of the latest written data in this write cycle.
11. Dout is the read data of next address.
12. If \overline{CS} is low during this period, I/O pins are in the output state. Therefore, the input signals of the opposite phase to the outputs must not be applied to them.
13. In the write cycle with \overline{OE} low fixed, t_{WP} must satisfy the following equation to avoid a problem of data bus contention.

$$t_{WP} \geq t_{DW} \text{ min} + t_{WHZ} \text{ max}$$

Timing Waveform

Read Timing Waveform (1) ($\overline{WE} = V_{IH}$)

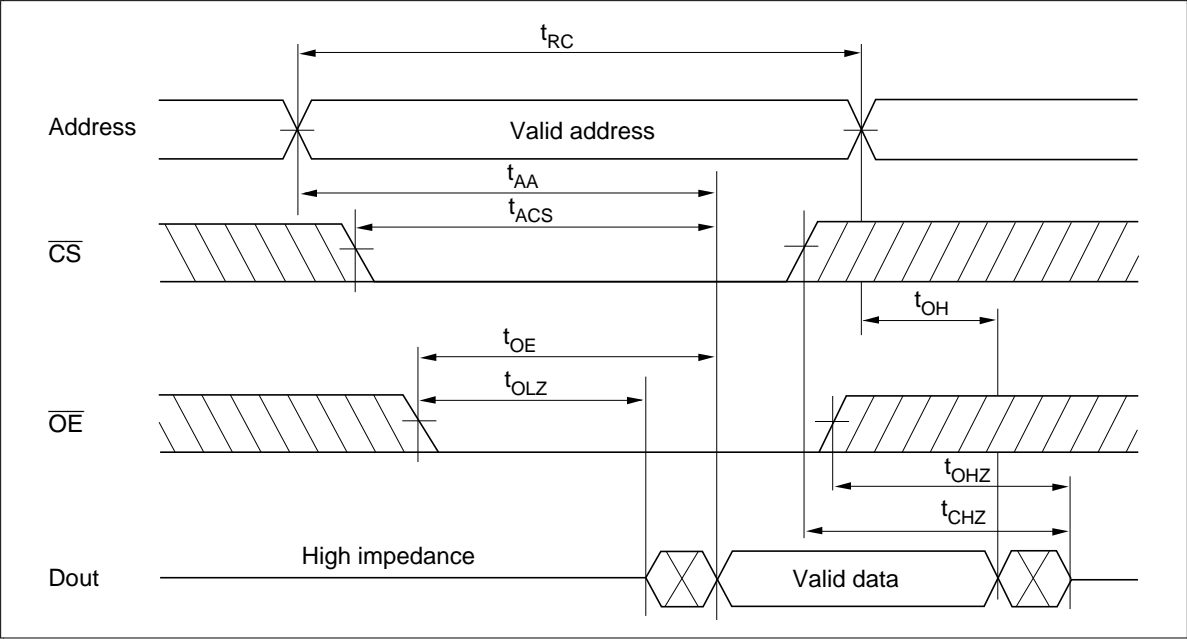

Read Timing Waveform (2) ($\overline{WE} = V_{IH}, \overline{CS} = V_{IL}, \overline{OE} = V_{IL}$)

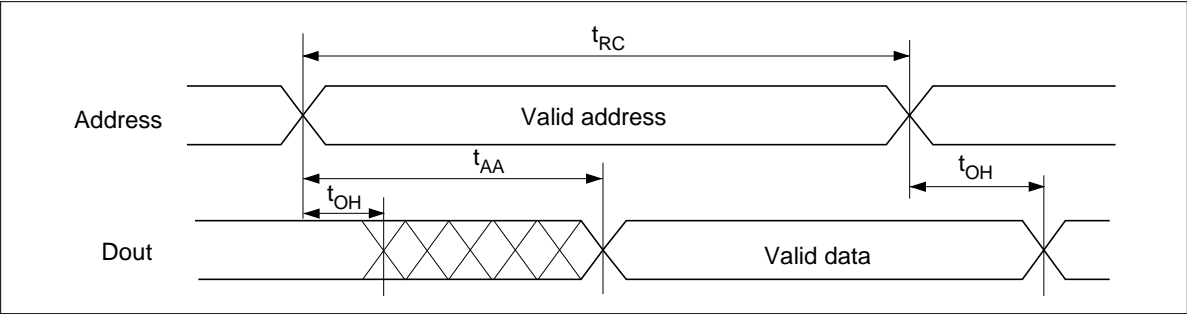

HM62256B Series

Read Timing Waveform (3) ($\overline{WE} = V_{IH}, \overline{OE} = V_{IL}$)*³

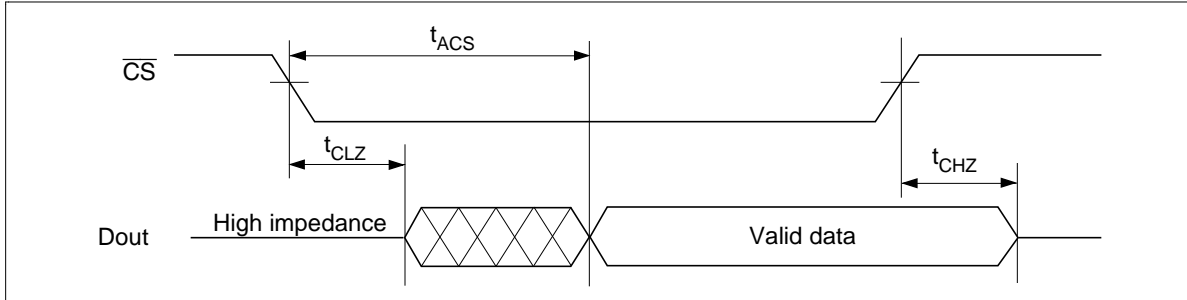

Write Timing Waveform (1) (\overline{OE} Clock)

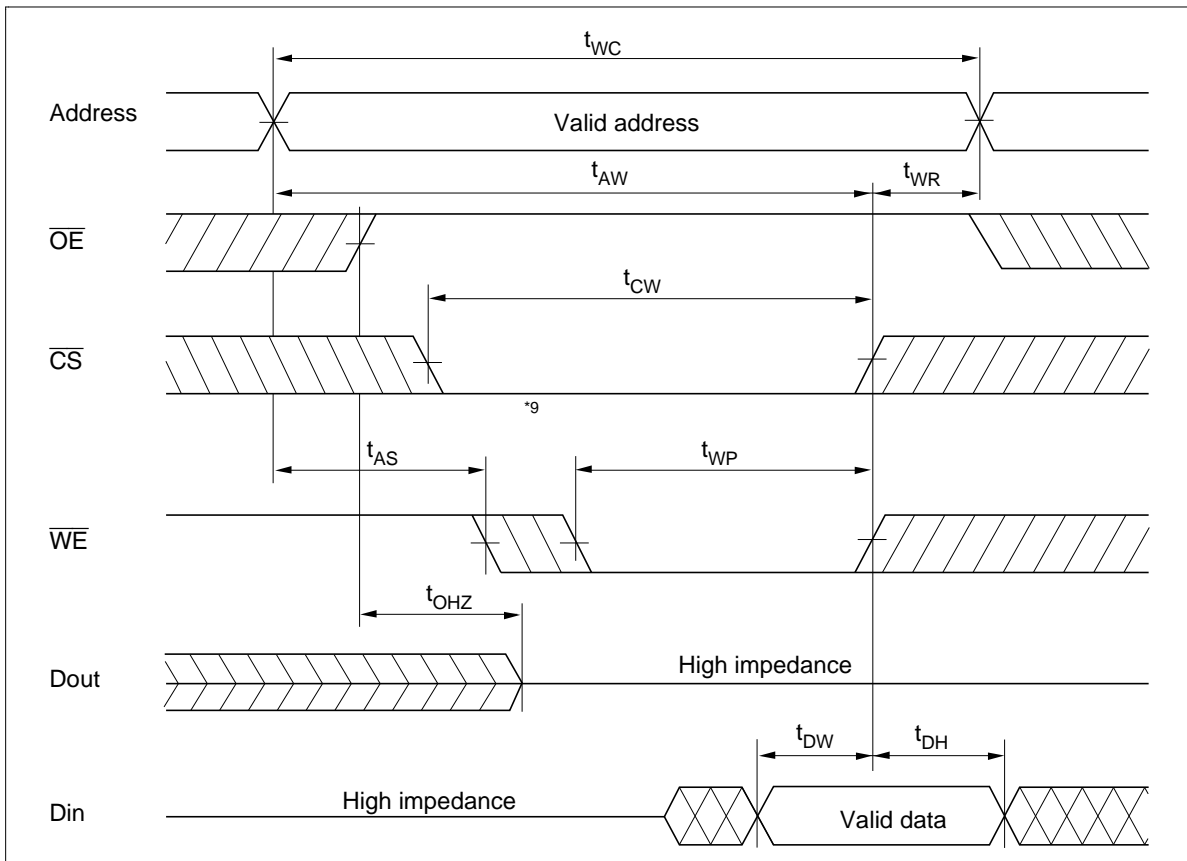

Write Timing Waveform (2) (\overline{OE} Low Fixed)

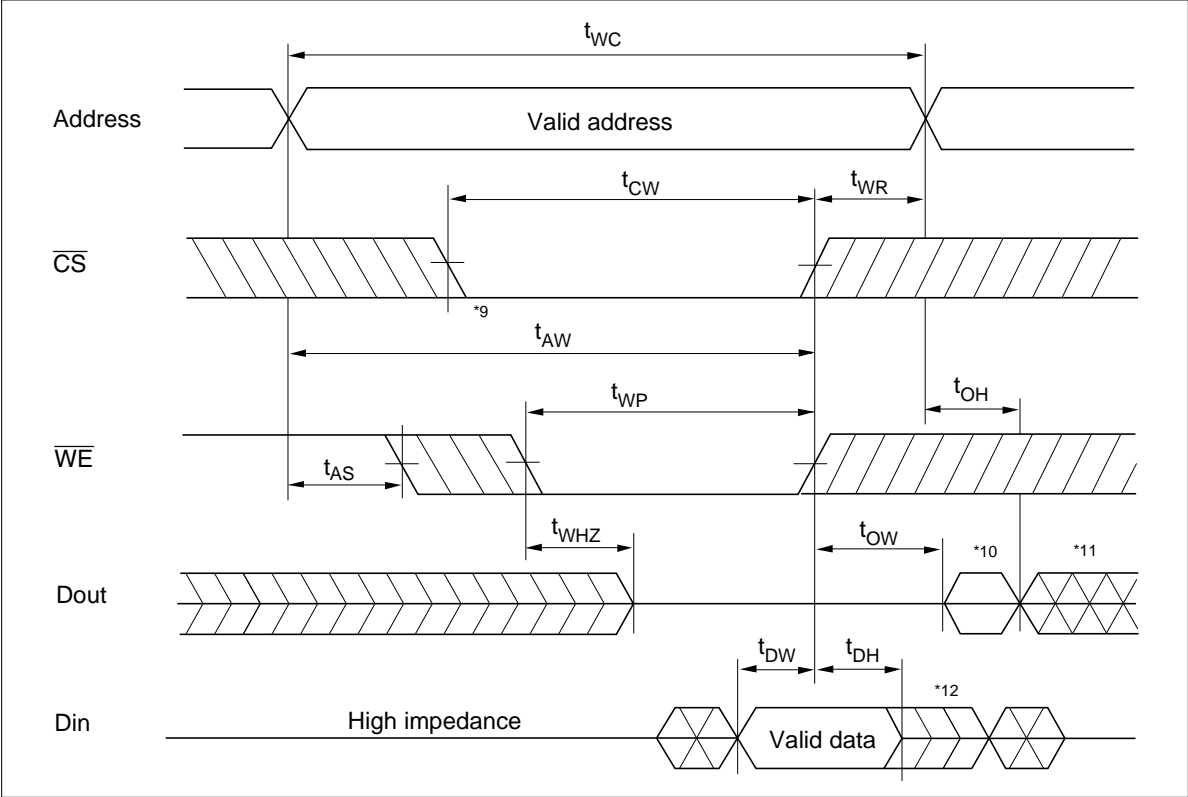

HM62256B Series

Low V_{CC} Data Retention Characteristics ($T_a = 0$ to 70°C)

Parameter	Symbol	Min	Typ ^{*1}	Max	Unit	Test conditions ^{*6}
V_{CC} for data retention	V_{DR}	2.0	—	5.5	V	$\overline{CS} \geq V_{CC} - 0.2\text{ V}$, $V_{in} \geq 0\text{ V}$
Data retention current	I_{CCDR}	—	0.05	30^{*2}	μA	$V_{CC} = 3.0\text{ V}$, $V_{in} \geq 0\text{ V}$ $\overline{CS} \geq V_{CC} - 0.2\text{ V}$
	I_{CCDR}	—	0.05	10^{*3}	μA	
	I_{CCDR}	—	0.05	3^{*4}	μA	
Chip deselect to data retention time	t_{CDR}	0	—	—	ns	See retention Waveform
Operation recovery time	t_R	t_{RC}^{*5}	—	—	ms	

Notes: 1. Typical values are at $V_{CC} = 3.0\text{ V}$, $T_a = +25^\circ\text{C}$ and not guaranteed.

2. $10\ \mu\text{A}$ max. at $T_a = 0$ to $+40^\circ\text{C}$.

3. This characteristic is guaranteed only for L-SL version, $3\ \mu\text{A}$ max. at $T_a = 0$ to $+40^\circ\text{C}$.

4. This characteristic is guaranteed only for L-UL version, $0.6\ \mu\text{A}$ max. at $T_a = 0$ to $+40^\circ\text{C}$.

5. t_{RC} = Read cycle time.

6. \overline{CS} controls address buffer, \overline{WE} buffer, \overline{OE} buffer, and Din buffer. If \overline{CS} controls data retention mode, V_{in} levels (address, \overline{WE} , \overline{OE} , I/O) can be in the high impedance state.

Low V_{CC} Data Retention Timing Waveform

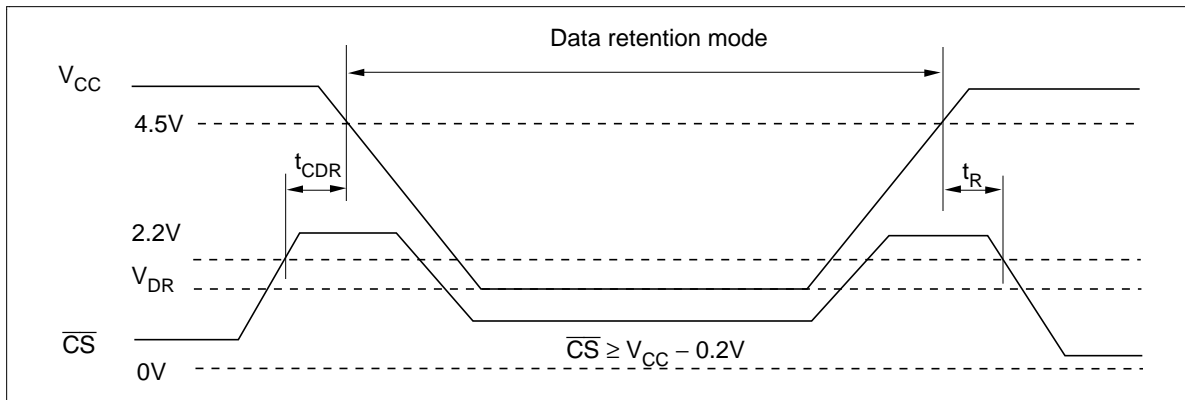

HM62256B Series

Package Dimensions

HM62256BLP Series (DP-28)

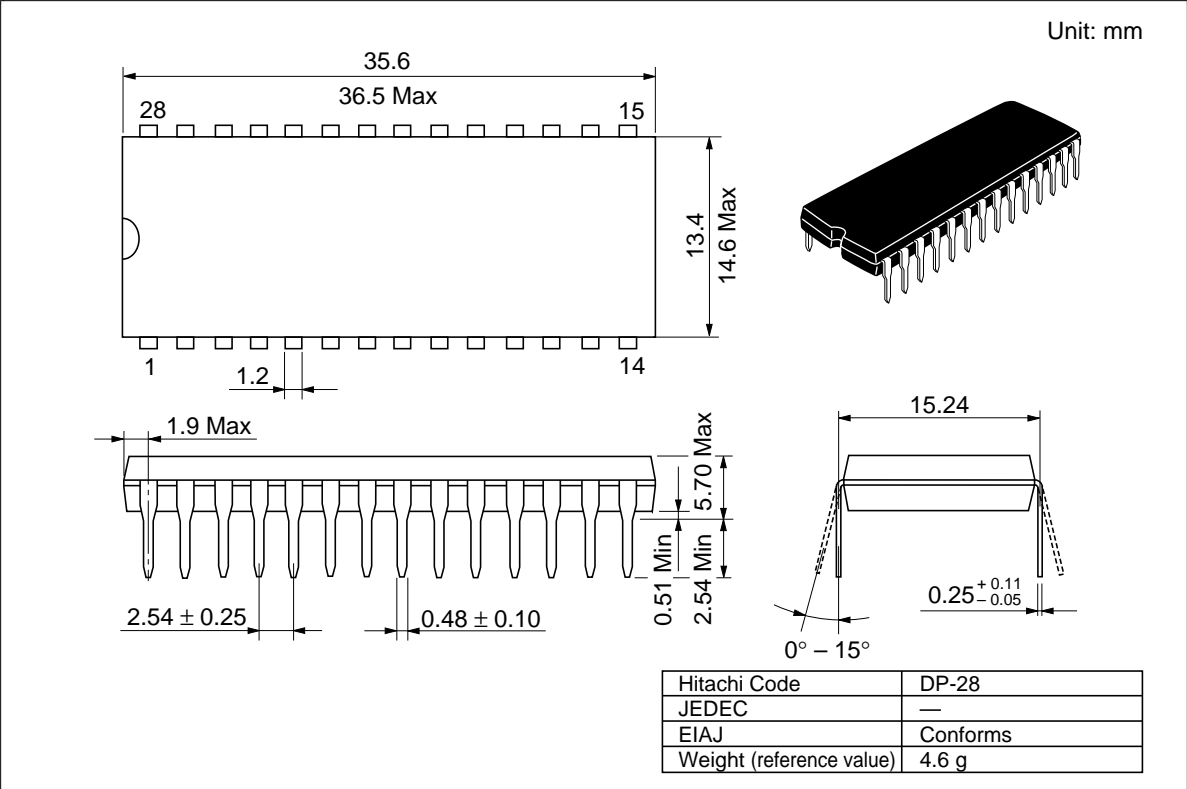

HM62256B Series

Package Dimensions (cont.)

HM62256BLSP Series (DP-28NA)

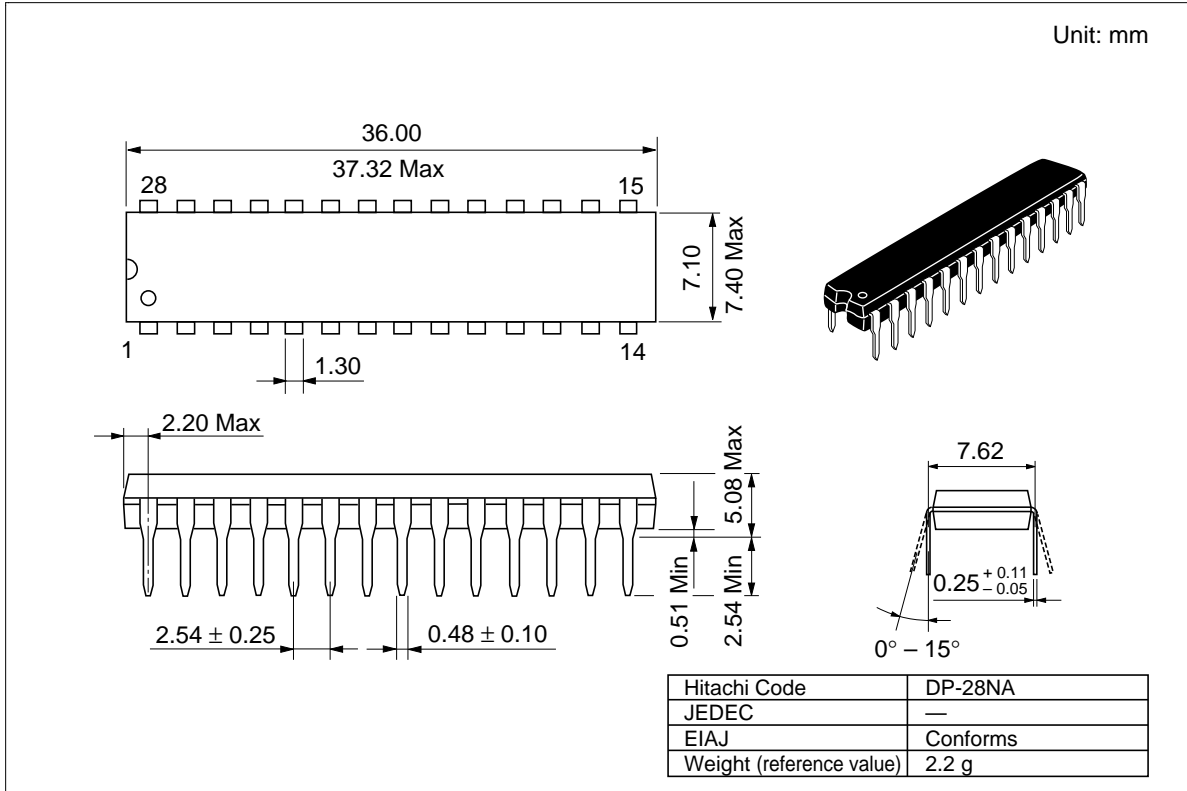

HM62256B Series

Package Dimensions (cont.)

HM62256BLFP Series (FP-28DA)

Unit: mm

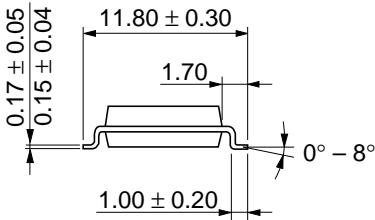
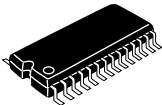
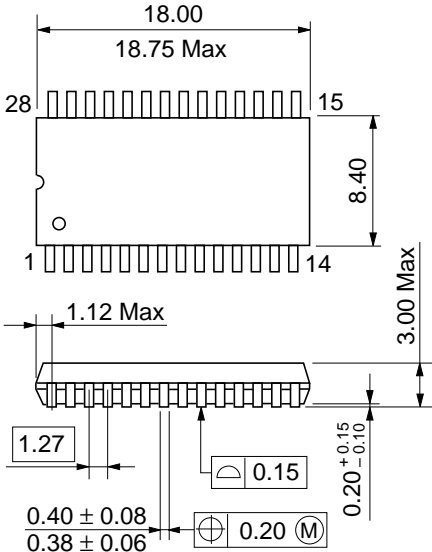

Dimension including the plating thickness
 Base material dimension

Hitachi Code	FP-28DA
JEDEC	Conforms
EIAJ	Conforms
Weight (reference value)	0.82 g

HM62256B Series

Package Dimensions (cont.)

HM62256BLTM Series (TFP-28DA)

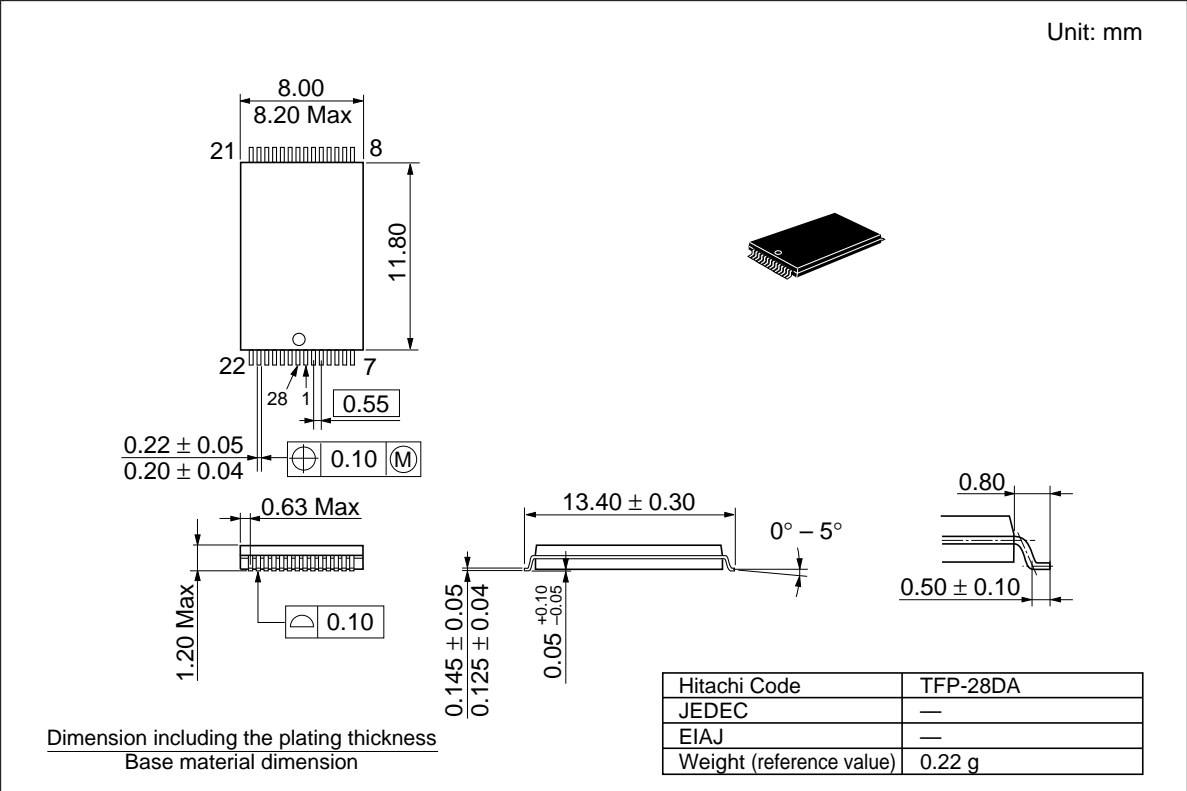

HM62256B Series

When using this document, keep the following in mind:

1. This document may, wholly or partially, be subject to change without notice.
2. All rights are reserved: No one is permitted to reproduce or duplicate, in any form, the whole or part of this document without Hitachi's permission.
3. Hitachi will not be held responsible for any damage to the user that may result from accidents or any other reasons during operation of the user's unit according to this document.
4. Circuitry and other examples described herein are meant merely to indicate the characteristics and performance of Hitachi's semiconductor products. Hitachi assumes no responsibility for any intellectual property claims or other problems that may result from applications based on the examples described herein.
5. No license is granted by implication or otherwise under any patents or other rights of any third party or Hitachi, Ltd.
6. **MEDICAL APPLICATIONS:** Hitachi's products are not authorized for use in **MEDICAL APPLICATIONS** without the written consent of the appropriate officer of Hitachi's sales company. Such use includes, but is not limited to, use in life support systems. Buyers of Hitachi's products are requested to notify the relevant Hitachi sales offices when planning to use the products in **MEDICAL APPLICATIONS**.

HITACHI

Hitachi, Ltd.

Semiconductor & IC Div.
Nippon Bldg., 2-6-2, Ohte-machi, Chiyoda-ku, Tokyo 100, Japan
Tel: Tokyo (03) 3270-2111
Fax: (03) 3270-5109

For further information write to:

Hitachi America, Ltd.
Semiconductor & IC Div.
2000 Sierra Point Parkway
Brisbane, CA. 94005-1835
U S A
Tel: 415-589-8300
Fax: 415-583-4207

Hitachi Europe GmbH
Continental Europe
Dornacher Straße 3
D-85622 Feldkirchen
München
Tel: 089-9 91 80-0
Fax: 089-9 29 30-00

Hitachi Europe Ltd.
Electronic Components Div.
Northern Europe Headquarters
Whitebrook Park
Lower Cookham Road
Maidenhead
Berkshire SL6 8YA
United Kingdom
Tel: 01628-585000
Fax: 01628-585160

Hitachi Asia Pte. Ltd.
16 Collyer Quay #20-00
Hitachi Tower
Singapore 049318
Tel: 535-2100
Fax: 535-1533

Hitachi Asia (Hong Kong) Ltd.
Unit 706, North Tower,
World Finance Centre,
Harbour City, Canton Road
Tsim Sha Tsui, Kowloon
Hong Kong
Tel: 27359218
Fax: 27306071

Copyright © Hitachi, Ltd., 1997. All rights reserved. Printed in Japan.

Revision Record

Rev.	Date	Contents of Modification	Drawn by	Approved by
0.0	Sep. 10, 1993	Initial Issue	Y. Saito	K. Yoshizaki
1.0	Mar. 23, 1994	DC Characteristics I _{CC1} Typ: —/—/—/— mA to 33/29/26/24 mA	Y. Saito	K. Yoshizaki
2.0	Oct. 31, 1994	Deletion of HM62256BLT-7/10SL/12SL Addition of HM62256BLTM-8/7SL/8SL(TFP-28DA) AC Characteristics Addition of note 12 Low V _{CC} data retention characteristics V _{DR} max: — to 5.5 V Note 2: 20 μA max at Ta = 0 to +40°C to 10 μA max at Ta = 0 to +40°C Deletion of description; (only for L-version)	Y. Saito	K. Yoshizaki
3.0	Jun. 19, 1995	Change of format Deletion of HM62256BLP-8/10/12/8SL/10SL/12SL Deletion of HM62256BLSP-8/10/12/8SL/10SL/12SL Deletion of HM62256BLFP-8T/10T/12T Deletion of HM62256BLFP-8SLT/10SLT/12SLT Deletion of HM62256BLT-10/12/8SL Deletion of HM62256BLTM-8SL Addition of HM62256BLFP-4SLT/5SLT/7ULT Addition of HM62256BLTM-4SLT/5SLT/7ULT Features Fast access time: 70/85/100/120 ns to 45/55/70/85 ns DC Characteristics I _{CC1} typ: 33/29/26/24 mA to —/—/33/29 mA max: 60/50/50/45 mA to 70/60/60/50 mA I _{SB1} typ: 0.3/0.3 μA to 0.2/0.2/0.2 μA max: 100/50 μA to 100/50/10 μA Addition of note 3 AC Characteristics Change order of notes. Test Condition Addition of HM62256B-4: 1TTL Gate + C _L (100pF) (Including scope & jig) t _{RC} min: 70/85/100/120 ns to 45/55/70/85 ns t _{AA} max: 70/85/100/120 ns to 45/55/70/85 ns t _{ACS} max: 70/85/100/120 ns to 45/55/70/85 ns t _{OE} max: 40/45/50/60 ns to 30/35/40/45 ns t _{CLZ} min: 10/10/10/10 ns to 5/5/10/10 ns t _{OHZ} max: 25/30/35/40 ns to 20/20/25/30 ns t _{OH} min: 5/5/10/10 ns 5/5/5/5 ns t _{WC} min: 70/85/100/120 ns to 45/55/70/85 ns t _{CW} min: 60/75/80/85 ns to 35/40/60/75 ns t _{AW} min: 60/75/80/85 ns to 35/40/60/75 ns t _{WP} min: 50/55/60/70 ns to 30/35/50/55 ns t _{WHZ} max: 25/30/35/40 ns to 20/20/25/30 ns	M. Higuchi	K. Yoshizaki

HM62256B Series

Revision Record (cont.)

Rev.	Date	Contents of Modification	Drawn by	Approved by
3.0	Jun. 19, 1995	AC Characteristics t_{PW} min: 30/35/40/50 ns to 20/25/30/35 ns t_{OHZ} max: 25/30/35/40 ns to 20/20/25/30 ns Low V_{CC} Data Retention Characteristics Addition of note 4. t_{CCDR} typ: 0.2/0.2 μ A to 0.05/0.05/0.05 μ A max: 30/10 μ A to 30/10/3 μ A	M. Higuchi	K. Yoshizaki
4.0	Nov. 29, 1995	Ordering Information (HM62256BLFP-4 Series) Addition of note (Under development) AC Characteristics Test Conditions HM62256-5/7/8:1TTL Gate + C_L (100pF) to HM62256-5:1TTL Gate + C_L (50pF) and HM62256-7/8:1TTL Gate + C_L (100pF)	M. Higuchi	K. Yoshizaki
5.0	Jul. 9, 1997	Change of format Deletion of HM62256B-4 Series	M. Higuchi	K. Imato
6.0	Nov. 13, 1997	Operation Table Correct Error DC Operating Conditions Correct Error DC Characteristics Correct Error		

This datasheet has been downloaded from:

www.DatasheetCatalog.com

Datasheets for electronic components.



LittleDiode supplies new, hard to find or obsolete electronic components and semiconductors all over the world.

With over two million different components listed you are sure to find the part you need.

Feel free to visit us today at our online store:

LittleDiode.com

Looking forward to providing you with the best possible service.