

---

# HM628128D Series

1 M SRAM (128-kword × 8-bit)

# HITACHI

ADE-203-996 (Z)  
Preliminary, Rev. 0.0  
Jan. 20, 1999

---

## Description

The Hitachi HM628128D Series is 1-Mbit static RAM organized 131,072-kword × 8-bit. HM628128D Series has realized higher density, higher performance and low power consumption by employing Hi-CMOS process technology. The HM628128D Series offers low power standby power dissipation; therefore, it is suitable for battery backup systems. It has package variations of standard 32-pin plastic DIP, standard 32-pin plastic SOP and standard 32-pin plastic TSOPI.

## Features

- Single 5 V supply: 5 V ± 10%
- Access time: 55 ns/70 ns (max)
- Power dissipation
  - Active: 30 mW/MHz (typ)
  - Standby: 10 μW (typ)
- Completely static memory.
  - No clock or timing strobe required
- Equal access and cycle times
- Common data input and output
  - Three state output
- Directly TTL compatible all inputs
- Battery backup operation
  - 2 chip selection for battery backup

---

## HM628128D Series

---

### Ordering Information

Type No.	Access time	Package
HM628128DLP-5	55 ns	600-mil 32-pin plastic DIP (DP-32)
HM628128DLP-7	70 ns	
HM628128DLP-5SL	55 ns	
HM628128DLP-7SL	70 ns	
HM628128DLP-5UL	55 ns	
HM628128DLP-7UL	70 ns	
HM628128DLFP-5	55 ns	525-mil 32-pin plastic SOP (FP-32D)
HM628128DLFP-7	70 ns	
HM628128DLFP-5SL	55 ns	
HM628128DLFP-7SL	70 ns	
HM628128DLFP-5UL	55 ns	
HM628128DLFP-7UL	70 ns	
HM628128DLTS-5	55 ns	8 × 13.4 mm 32-pin plastic TSOP I (TFP-32DC)
HM628128DLTS-7	70 ns	
HM628128DLTS-5SL	55 ns	
HM628128DLTS-7SL	70 ns	
HM628128DLTS-5UL	55 ns	
HM628128DLTS-7UL	70 ns	
HM628128DLT-5	55 ns	Normal-bend type 8 × 20 mm 32-pin plastic TSOP I (TFP-32D)
HM628128DLT-7	70 ns	
HM628128DLT-5SL	55 ns	
HM628128DLT-7SL	70 ns	
HM628128DLT-5UL	55 ns	
HM628128DLT-7UL	70 ns	
HM628128DLR-5	55 ns	Reverse-bend type 8 × 20 mm 32-pin plastic TSOP I (TFP-32DR)
HM628128DLR-7	70 ns	
HM628128DLR-5SL	55 ns	
HM628128DLR-7SL	70 ns	
HM628128DLR-5UL	55 ns	
HM628128DLR-7UL	70 ns	

## Pin Arrangement

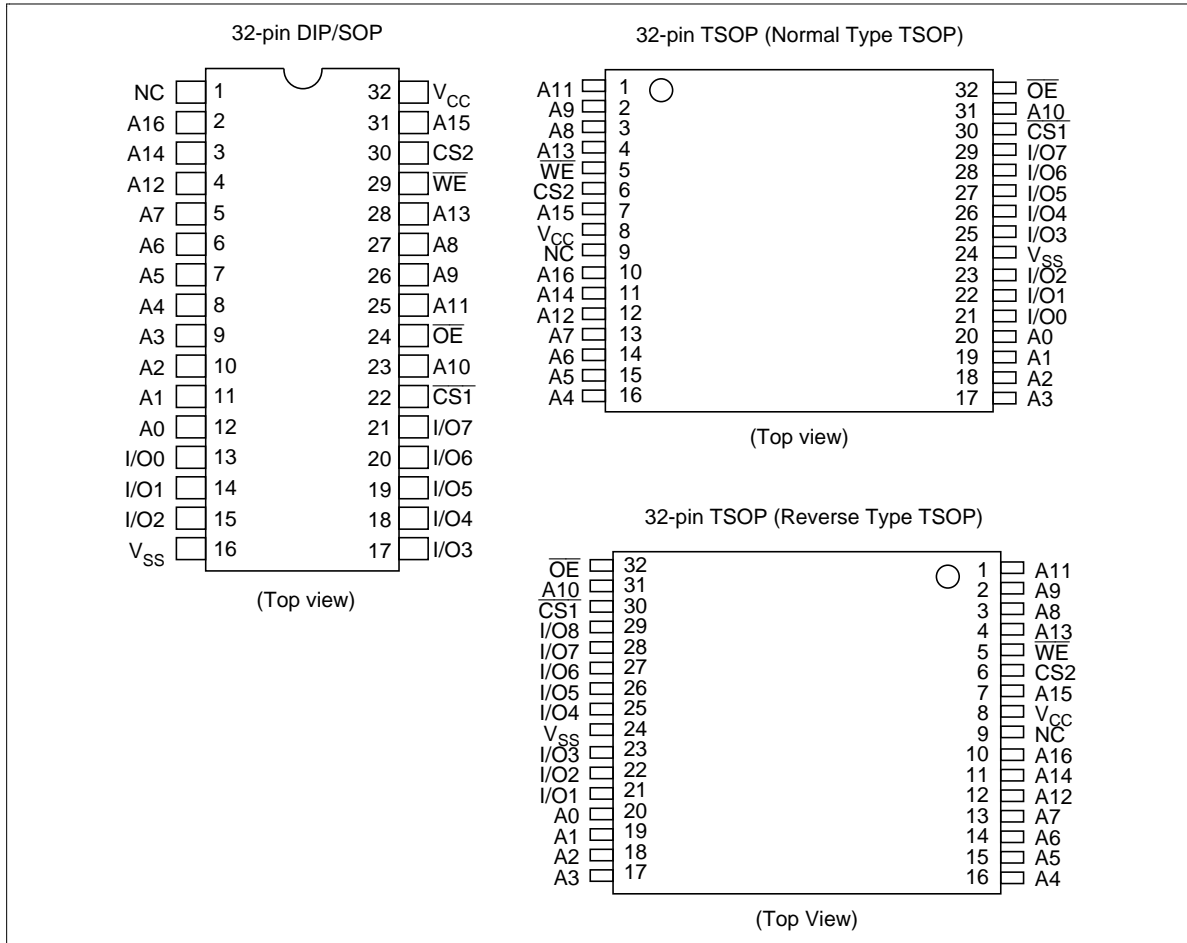

## Pin Description

Pin name	Function
A0 to A16	Address input
I/O0 to I/O7	Data input/output
$\overline{CS1}$	Chip select 1
CS2	Chip select 2
$\overline{WE}$	Write enable
$\overline{OE}$	Output enable
V <sub>cc</sub>	Power supply
V <sub>ss</sub>	Ground
NC	No connection

# HM628128D Series

## Block Diagram

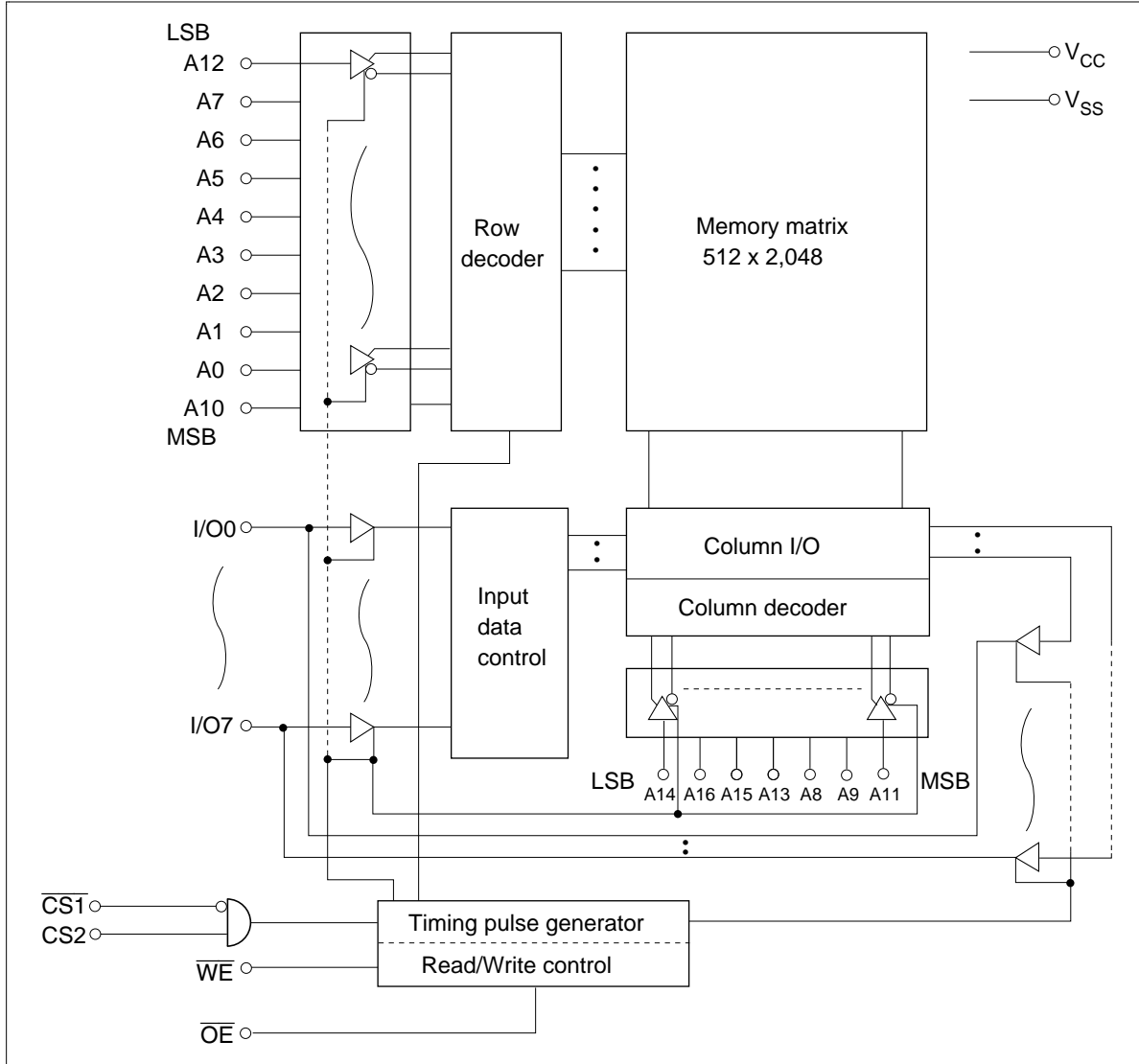

**Operation Table**

$\overline{CS1}$	CS2	$\overline{WE}$	$\overline{OE}$	I/O	Operation
H	H	×	×	High-Z	Standby
L	L	×	×	High-Z	Standby
L	L	×	×	High-Z	Standby
L	H	H	L	Dout	Read
L	H	L	H	Din	Write
L	H	L	L	Din	Write
L	H	H	H	High-Z	Output disable

Note: H:  $V_{IH}$ , L:  $V_{IL}$ , ×:  $V_{IH}$  or  $V_{IL}$

**Absolute Maximum Ratings**

Parameter	Symbol	Value	Unit
Power supply voltage relative to $V_{SS}$	$V_{CC}$	-0.5 to +7.0	V
Terminal voltage on any pin relative to $V_{SS}$	$V_T$	-0.5* <sup>1</sup> to $V_{CC} + 0.3$ * <sup>2</sup>	V
Power dissipation	$P_T$	1.0	W
Storage temperature range	Tstg	-55 to +125	°C
Storage temperature range under bias	Tbias	-20 to +85	°C

Notes: 1.  $V_T$  min: -1.5 V for pulse half-width  $\leq 30$  ns  
 2. Maximum voltage is +7.0 V

**DC Operating Conditions**

Parameter	Symbol	Min	Typ	Max	Unit	Note
Supply voltage	$V_{CC}$	4.5	5.0	5.5	V	
	$V_{SS}$	0	0	0	V	
Input high voltage	$V_{IH}$	2.2	—	$V_{CC} + 0.3$	V	
Input low voltage	$V_{IL}$	-0.3	—	0.8	V	1
Ambient temperature range	Ta	-20	—	+70	°C	

Note: 1.  $V_{IL}$  min: -1.5 V for pulse half-width  $\leq 30$  ns

## HM628128D Series

### DC Characteristics

Parameter	Symbol	Min	Typ* <sup>1</sup>	Max	Unit	Test conditions
Input leakage current	$ I_{LI} $	—	—	1	$\mu\text{A}$	$V_{in} = V_{SS} \text{ to } V_{CC}$
Output leakage current	$ I_{LO} $	—	—	1	$\mu\text{A}$	$\overline{CS1} = V_{IH}$ or $CS2 = V_{IL}$ or $OE = V_{IH}$ or $\overline{WE} = V_{IL}$ , $V_{I/O} = V_{SS} \text{ to } V_{CC}$
Operating current	$I_{CC}$	—	—	15	$\text{mA}$	$\overline{CS1} = V_{IL}$ , $CS2 = V_{IH}$ , others = $V_{IH}/V_{IL}$ , $I_{I/O} = 0 \text{ mA}$
Average operating current	$I_{CC1}$	—	—	60	$\text{mA}$	Min cycle, duty = 100% $I_{I/O} = 0 \text{ mA}$ , $\overline{CS1} = V_{IL}$ , $CS2 = V_{IH}$ , Others = $V_{IH}/V_{IL}$
	$I_{CC2}$	—	6	20	$\text{mA}$	Cycle time = 1 $\mu\text{s}$ , duty = 100%, $I_{I/O} = 0 \text{ mA}$ , $\overline{CS1} \leq 0.2 \text{ V}$ , $CS2 \geq V_{CC} - 0.2 \text{ V}$ , $V_{IH} \geq V_{CC} - 0.2 \text{ V}$ , $V_{IL} \leq 0.2 \text{ V}$
Standby current	$I_{SB}$	—	—	2	$\text{mA}$	(1) $\overline{CS1} = V_{IH}$ , $CS2 = V_{IH}$ , or (2) $CS2 = V_{IL}$
	$I_{SB1}^{*2}$	—	2	100	$\mu\text{A}$	0 V $\leq V_{in}$ (1) 0 V $\leq CS2 \leq 0.2 \text{ V}$ or (2) $\overline{CS1} \geq V_{CC} - 0.2 \text{ V}$ , $CS2 \geq V_{CC} - 0.2 \text{ V}$
	$I_{SB1}^{*3}$	—	2	50	$\mu\text{A}$	
	$I_{SB1}^{*4}$	—	1	20	$\mu\text{A}$	
Output high voltage	$V_{OH}$	2.4	—	—	V	$I_{OH} = -1 \text{ mA}$
Output low voltage	$V_{OL}$	—	—	0.4	V	$I_{OL} = 2.1 \text{ mA}$

- Notes: 1. Typical values are at  $V_{CC} = 5.0 \text{ V}$ ,  $T_a = +25^\circ\text{C}$  and specified loading, and not guaranteed.  
 2. This characteristics is guaranteed only for L version.  
 3. This characteristics is guaranteed only for L-SL version.  
 4. This characteristics is guaranteed only for L-UL version.

### Capacitance ( $T_a = +25^\circ\text{C}$ , $f = 1 \text{ MHz}$ )

Parameter	Symbol	Typ	Max	Unit	Test conditions	Note
Input capacitance	$C_{in}$	—	8	$\text{pF}$	$V_{in} = 0 \text{ V}$	1
Input/output capacitance	$C_{I/O}$	—	10	$\text{pF}$	$V_{I/O} = 0 \text{ V}$	1

- Note: 1. This parameter is sampled and not 100% tested.

## HM628128D Series

**AC Characteristics** ( $T_a = -20$  to  $+70^\circ\text{C}$ ,  $V_{CC} = 5.0\text{ V} \pm 10\%$ , unless otherwise noted.)

### Test Conditions

- Input pulse levels:  $V_{IL} = 0.8\text{ V}$ ,  $V_{IH} = 2.4\text{ V}$
- Input rise and fall time: 5 ns
- Input timing reference levels: 1.5 V
- Output timing reference level: 1.5 V
- Output load: 1 TTL Gate+ CL (100 pF) (HM628128D-7)  
1 TTL Gate+ CL (50 pF) (HM628128D-5)  
(Including scope and jig)

### Read Cycle

HM628128D							
		-5		-7			
Parameter	Symbol	Min	Max	Min	Max	Unit	Notes
Read cycle time	$t_{RC}$	55	—	70	—	ns	
Address access time	$t_{AA}$	—	55	—	70	ns	
Chip select access time	$t_{ACS1}$	—	55	—	70	ns	
	$t_{ACS2}$	—	55	—	70	ns	
Output enable to output valid	$t_{OE}$	—	30	—	35	ns	
Output hold from address change	$t_{OH}$	10	—	10	—	ns	
Chip selection to output in low-Z	$t_{CLZ1}$	10	—	10	—	ns	2, 3
	$t_{CLZ2}$	10	—	10	—	ns	2, 3
Output enable to output in low-Z	$t_{OLZ}$	5	—	5	—	ns	2, 3
Chip deselection to output in high-Z	$t_{CHZ1}$	0	20	0	25	ns	1, 2, 3
	$t_{CHZ2}$	0	20	0	25	ns	1, 2, 3
Output disable to output in high-Z	$t_{OHZ}$	0	20	0	25	ns	1, 2, 3

## HM628128D Series

### Write Cycle

HM628128D							
		-5		-7			
Parameter	Symbol	Min	Max	Min	Max	Unit	Notes
Write cycle time	$t_{WC}$	55	—	70	—	ns	
Address valid to end of write	$t_{AW}$	50	—	60	—	ns	
Chip selection to end of write	$t_{CW}$	50	—	60	—	ns	5
Write pulse width	$t_{WP}$	40	—	50	—	ns	4, 13
Address setup time	$t_{AS}$	0	—	0	—	ns	6
Write recovery time	$t_{WR}$	0	—	0	—	ns	7
Data to write time overlap	$t_{DW}$	20	—	25	—	ns	
Data hold from write time	$t_{DH}$	0	—	0	—	ns	
Output active from output in high-Z	$t_{OW}$	5	—	5	—	ns	2
Output disable to output in high-Z	$t_{OHZ}$	0	20	0	25	ns	1, 2, 8
$\overline{WE}$ to output in high-Z	$t_{WHZ}$	0	20	0	25	ns	1, 2, 8

- Notes:
- $t_{CHZ}$ ,  $t_{OHZ}$  and  $t_{WHZ}$  are defined as the time at which the outputs achieve the open circuit conditions and are not referred to output voltage levels.
  - This parameter is sampled and not 100% tested.
  - At any given temperature and voltage condition,  $t_{HZ}$  max is less than  $t_{LZ}$  min both for a given device and from device to device.
  - A write occurs during the overlap ( $t_{WP}$ ) of a low  $\overline{CS1}$ , a high CS2, and a low  $\overline{WE}$ . A write begins at the later transition of  $\overline{CS1}$  going low, CS2 going high, or  $\overline{WE}$  going low. A write ends at the earlier transition of  $\overline{CS1}$  going high, CS2 going low, or  $\overline{WE}$  going high.  $t_{WP}$  is measured from the beginning of write to the end of write.
  - $t_{CW}$  is measured from  $\overline{CS1}$  going low or CS2 going high to the end of write.
  - $t_{AS}$  is measured from the address valid to the beginning of write.
  - $t_{WR}$  is measured from the earlier of  $\overline{WE}$  or  $\overline{CS1}$  going high or CS2 going low to the end of write cycle.
  - During this period, I/O pins are in the output state; therefore, the input signals of the opposite phase to the outputs must not be applied.
  - If the  $\overline{CS1}$  goes low or CS2 going high simultaneously with  $\overline{WE}$  going low or after  $\overline{WE}$  going low, the output remain in a high impedance state.
  - Dout is the same phase of the write data of this write cycle.
  - Dout is the read data of next address.
  - If  $\overline{CS1}$  is low and CS2 high during this period, I/O pins are in the output state. Therefore, the input signals of the opposite phase to the outputs must not be applied to them.
  - In the write cycle with  $\overline{OE}$  low fixed,  $t_{WP}$  must satisfy the following equation to avoid a problem of data bus contention.  $t_{WP} \geq t_{DW} \text{ min} + t_{WHZ} \text{ max}$

Timing Waveforms

Read Cycle ( $\overline{WE} = V_{IH}$ )

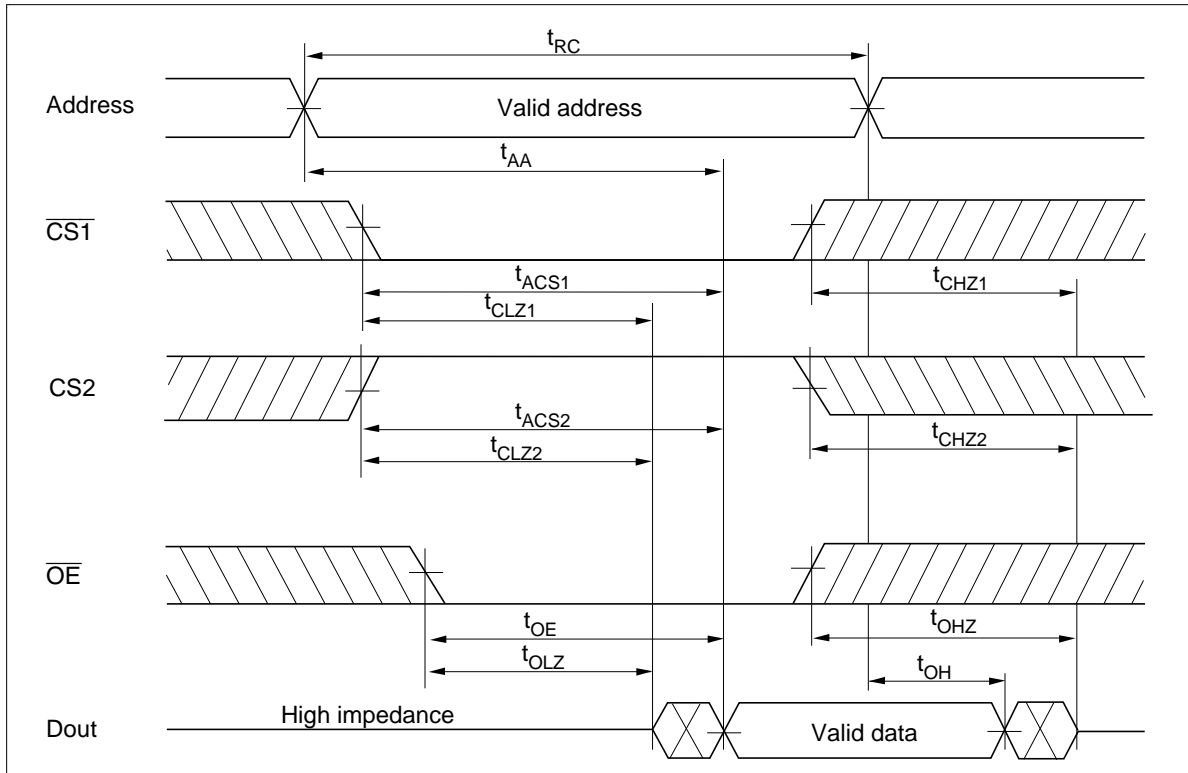

# HM628128D Series

## Write Cycle (1) ( $\overline{\text{OE}}$ Clock)

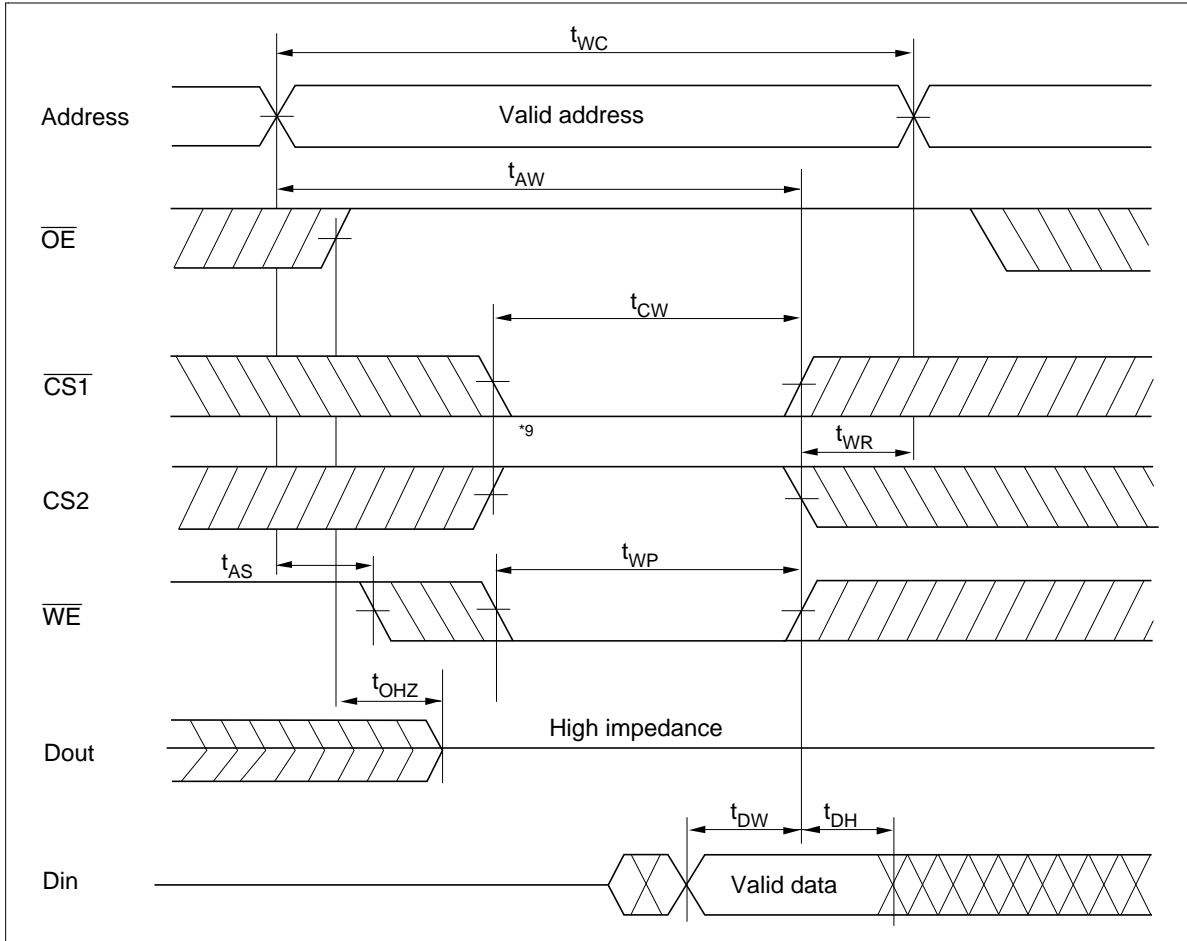

Write Cycle (2) ( $\overline{OE} = V_{IL}$ )

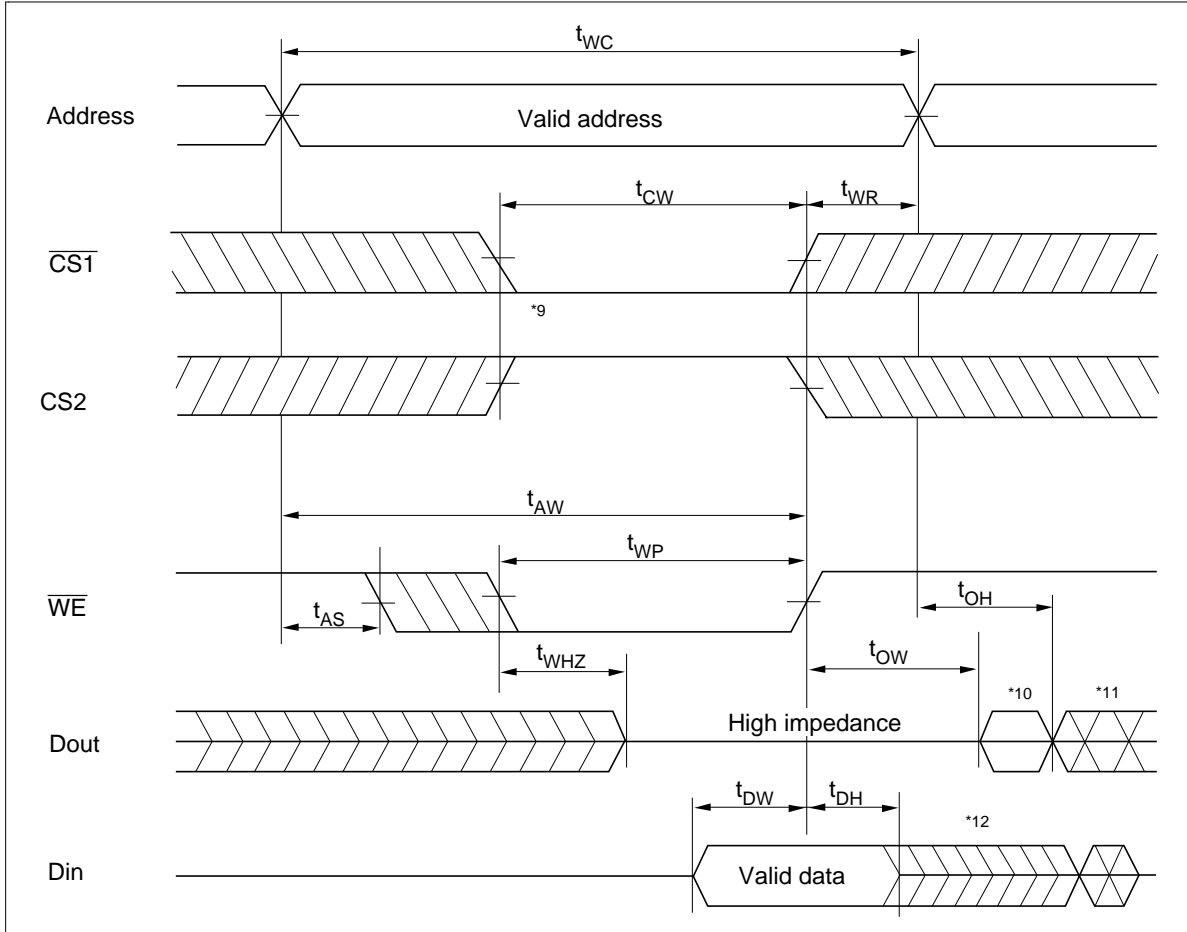

## HM628128D Series

### Low $V_{CC}$ Data Retention Characteristics ( $T_a = -20$ to $+70^\circ\text{C}$ )

Parameter	Symbol	Min	Typ <sup>*5</sup>	Max	Unit	Test conditions <sup>*4</sup>
$V_{CC}$ for data retention	$V_{DR}$	2.0	—	—	V	$V_{in} \geq 0\text{V}$ (1) $0\text{V} \leq \text{CS2} \leq 0.2\text{V}$ or (2) $\text{CS2} \geq V_{CC} - 0.2\text{V}$ $\text{CS1} \geq V_{CC} - 0.2\text{V}$
Data retention current	$I_{CCDR}^{*1}$	—	1.0	50	$\mu\text{A}$	$V_{CC} = 3.0\text{V}$ , $V_{in} \geq 0\text{V}$ (1) $0\text{V} \leq \text{CS2} \leq 0.2\text{V}$ or (2) $\text{CS2} \geq V_{CC} - 0.2\text{V}$ , $\text{CS1} \geq V_{CC} - 0.2\text{V}$
	$I_{CCDR}^{*2}$	—	1.0	15	$\mu\text{A}$	
	$I_{CCDR}^{*3}$	—	0.5	10	$\mu\text{A}$	
Chip deselect to data retention time	$t_{CDR}$	0	—	—	ns	See retention waveform
Operation recovery time	$t_R$	$t_{RC}^{*6}$	—	—	ns	

- Notes:
1. This characteristic is guaranteed only for L-version, 20  $\mu\text{A}$  max. at  $T_a = -20$  to  $+40^\circ\text{C}$ .
  2. This characteristic is guaranteed only for L-SL-version, 3  $\mu\text{A}$  max. at  $T_a = -20$  to  $+40^\circ\text{C}$ .
  3. This characteristic is guaranteed only for L-UL-version, 1  $\mu\text{A}$  max. at  $T_a = -20$  to  $+40^\circ\text{C}$ .
  4. CS2 controls address buffer,  $\overline{\text{WE}}$  buffer,  $\overline{\text{CS1}}$  buffer,  $\overline{\text{OE}}$  buffer, and Din buffer. If CS2 controls data retention mode,  $V_{in}$  levels (address,  $\overline{\text{WE}}$ ,  $\overline{\text{OE}}$ ,  $\overline{\text{CS1}}$ , I/O) can be in the high impedance state. If  $\overline{\text{CS1}}$  controls data retention mode, CS2 must be  $\text{CS2} \geq V_{CC} - 0.2\text{V}$  or  $0\text{V} \leq \text{CS2} \leq 0.2\text{V}$ . The other input levels (address,  $\overline{\text{WE}}$ ,  $\overline{\text{OE}}$ , I/O) can be in the high impedance state.
  5. Typical values are at  $V_{CC} = 3.0\text{V}$ ,  $T_a = +25^\circ\text{C}$  and specified loading, and not guaranteed.
  6.  $t_{RC}$  = read cycle time.

### Low $V_{CC}$ Data Retention Timing Waveform (1) ( $\overline{\text{CS1}}$ Controlled)

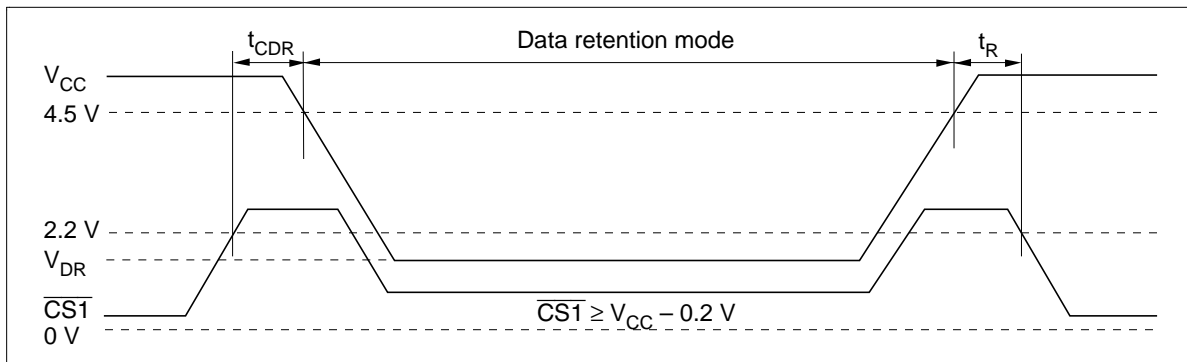

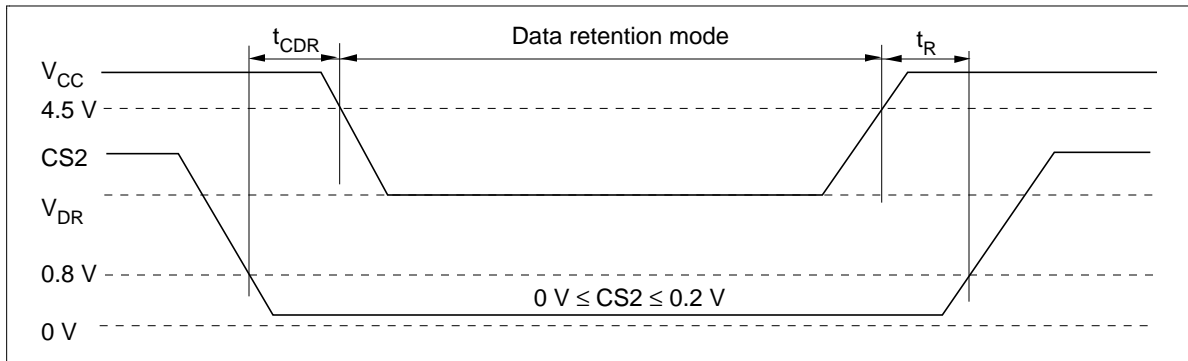
**Low  $V_{CC}$  Data Retention Timing Waveform (2) (CS2 Controlled)**

# HM628128D Series

## Package Dimensions

### HM628128DLP Series (DP-32)

Unit: mm

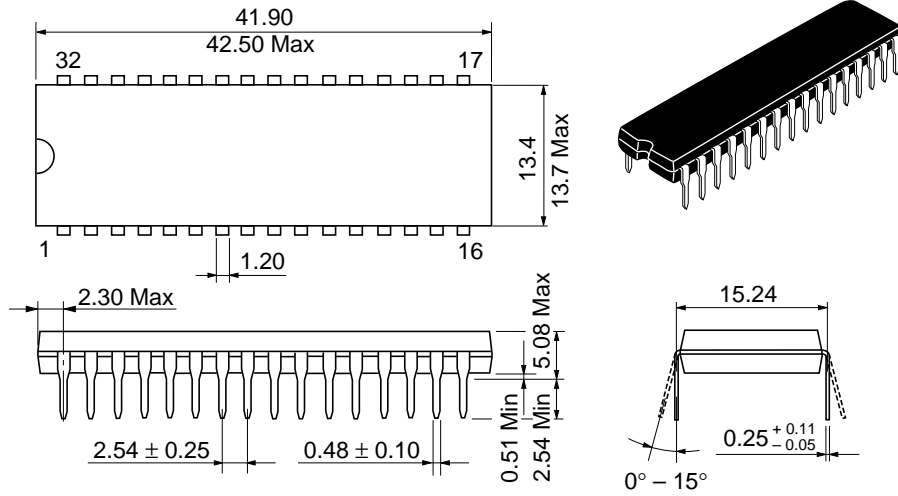

Hitachi Code	DP-32
JEDEC	—
EIAJ	Conforms
Weight (reference value)	5.1 g

# HM628128D Series

## HM628128DLFP Series (FP-32D)

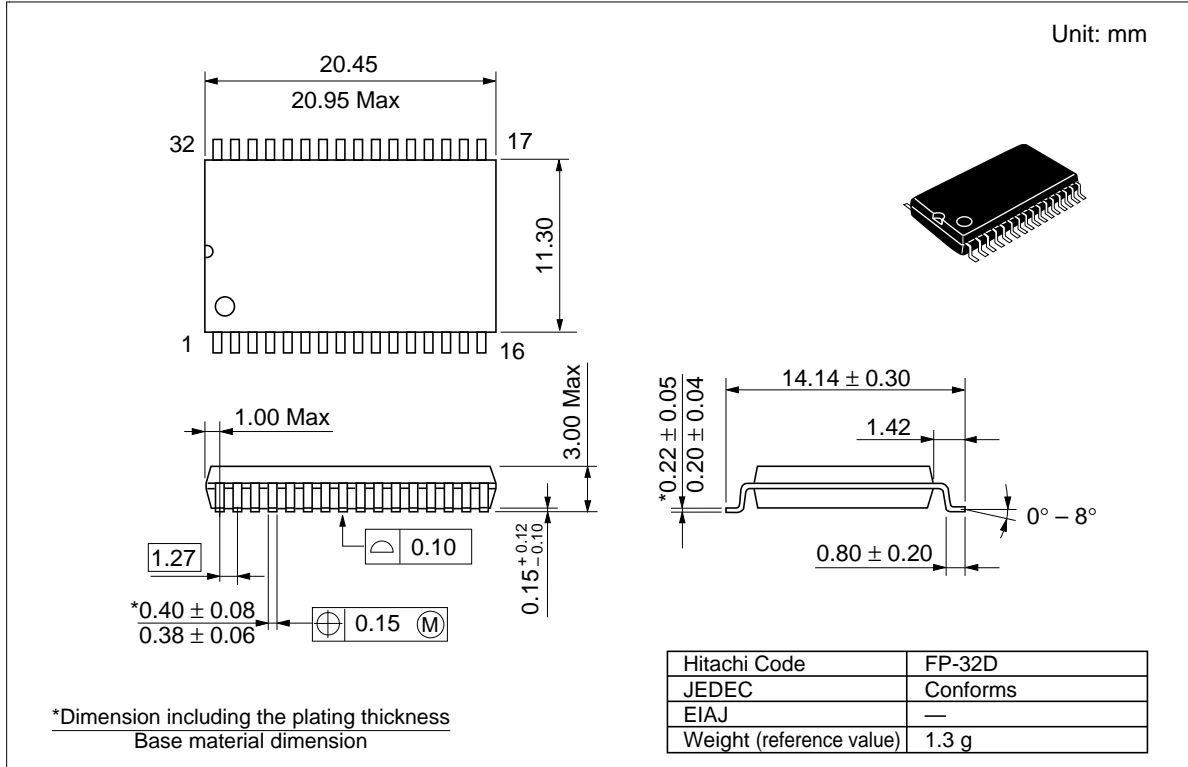

# HM628128D Series

## HM628128DLTS Series (TFP-32DC)

Unit: mm

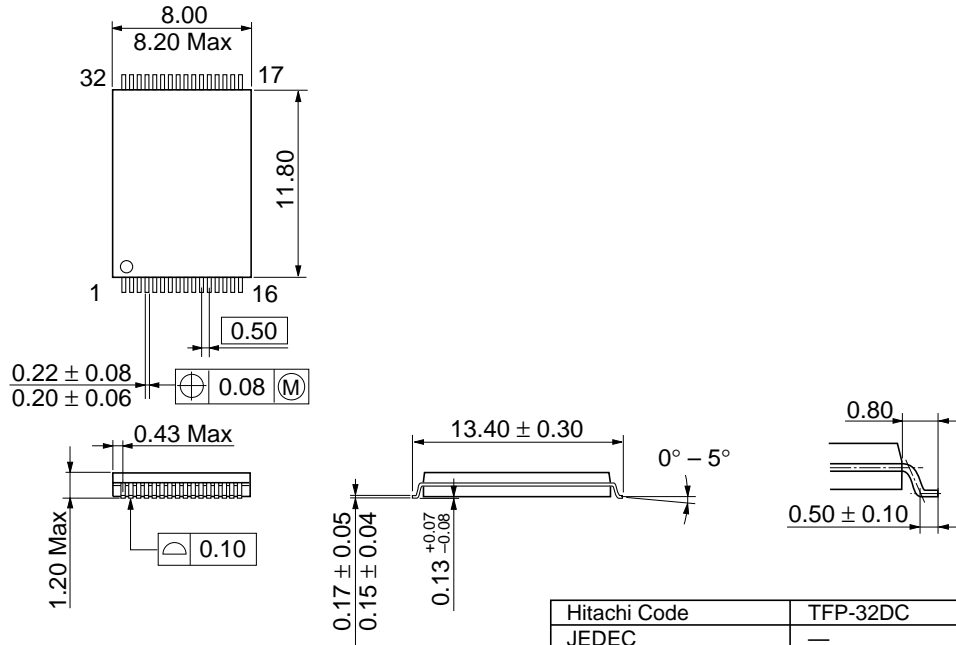

Dimension including the plating thickness  
Base material dimension

Hitachi Code	TFP-32DC
JEDEC	—
EIAJ	—
Weight (reference value)	0.23 g

# HM628128D Series

## HM628128DLT Series (TFP-32D)

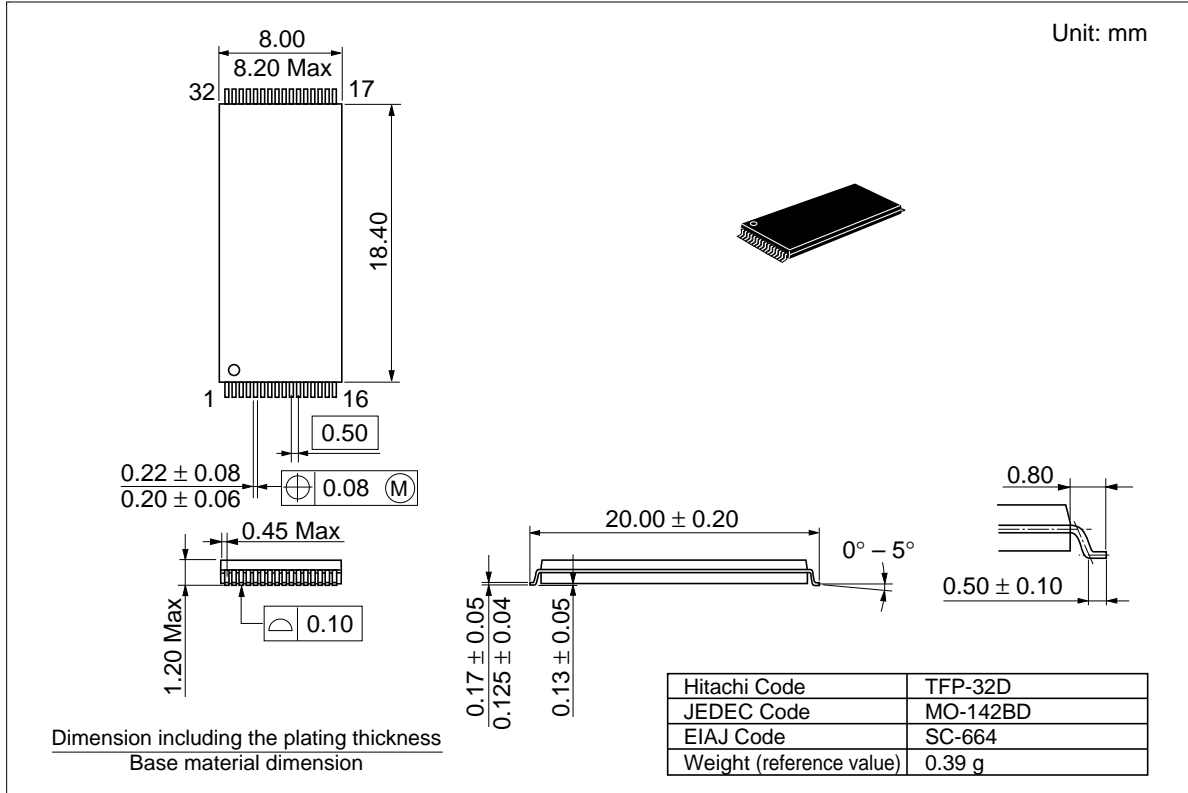

# HM628128D Series

## HM628128DLR Series (TFP-32DR)

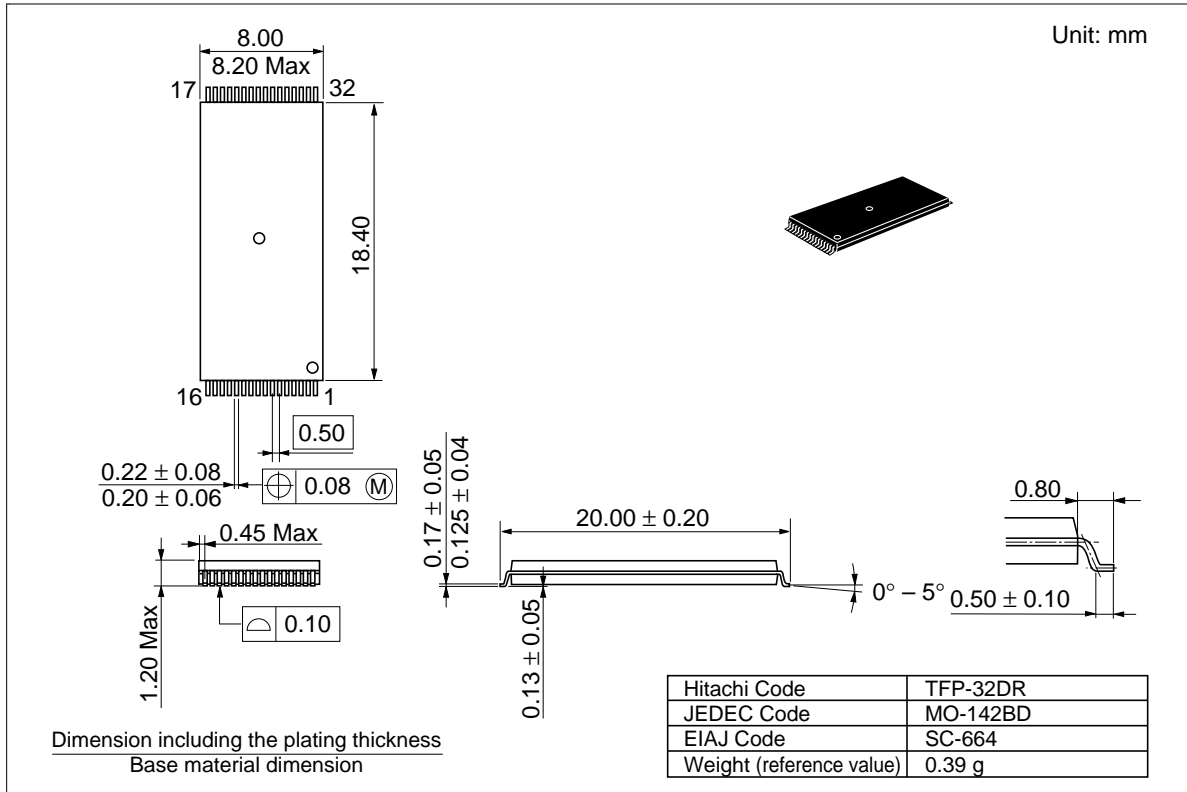

**Cautions**

1. Hitachi neither warrants nor grants licenses of any rights of Hitachi's or any third party's patent, copyright, trademark, or other intellectual property rights for information contained in this document. Hitachi bears no responsibility for problems that may arise with third party's rights, including intellectual property rights, in connection with use of the information contained in this document.
2. Products and product specifications may be subject to change without notice. Confirm that you have received the latest product standards or specifications before final design, purchase or use.
3. Hitachi makes every attempt to ensure that its products are of high quality and reliability. However, contact Hitachi's sales office before using the product in an application that demands especially high quality and reliability or where its failure or malfunction may directly threaten human life or cause risk of bodily injury, such as aerospace, aeronautics, nuclear power, combustion control, transportation, traffic, safety equipment or medical equipment for life support.
4. Design your application so that the product is used within the ranges guaranteed by Hitachi particularly for maximum rating, operating supply voltage range, heat radiation characteristics, installation conditions and other characteristics. Hitachi bears no responsibility for failure or damage when used beyond the guaranteed ranges. Even within the guaranteed ranges, consider normally foreseeable failure rates or failure modes in semiconductor devices and employ systemic measures such as fail-safes, so that the equipment incorporating Hitachi product does not cause bodily injury, fire or other consequential damage due to operation of the Hitachi product.
5. This product is not designed to be radiation resistant.
6. No one is permitted to reproduce or duplicate, in any form, the whole or part of this document without written approval from Hitachi.
7. Contact Hitachi's sales office for any questions regarding this document or Hitachi semiconductor products.

---

---

**HITACHI****Hitachi, Ltd.**

Semiconductor & IC Div.  
Nippon Bldg., 2-6-2, Ohte-machi, Chiyoda-ku, Tokyo 100-0004, Japan  
Tel: Tokyo (03) 3270-2111 Fax: (03) 3270-5109

URL      North America      : <http://semiconductor.hitachi.com/>  
             Europe                : <http://www.hitachi-eu.com/hel/ecg>  
             Asia (Singapore)      : <http://www.has.hitachi.com.sg/grp3/sicd/index.htm>  
             Asia (Taiwan)         : [http://www.hitachi.com.tw/E/Product/SICD\\_Frame.htm](http://www.hitachi.com.tw/E/Product/SICD_Frame.htm)  
             Asia (HongKong)      : <http://www.hitachi.com.hk/eng/bo/grp3/index.htm>  
             Japan                    : <http://www.hitachi.co.jp/Sicd/indx.htm>

**For further information write to:**

Hitachi Semiconductor  
(America) Inc.  
2000 Sierra Point Parkway  
Brisbane, CA 94005-1897  
Tel: <1> (800) 285-1601  
Fax: <1> (303) 297-0447

Hitachi Europe GmbH  
Electronic components Group  
Dornacher Straße 3  
D-85622 Feldkirchen, Munich  
Germany  
Tel: <49> (89) 9 9180-0  
Fax: <49> (89) 9 29 30 00

Hitachi Europe Ltd.  
Electronic Components Group.  
Whitebrook Park  
Lower Cookham Road  
Maidenhead  
Berkshire SL6 8YA, United Kingdom  
Tel: <44> (1628) 585000  
Fax: <44> (1628) 778322

Hitachi Asia Pte. Ltd.  
16 Collyer Quay #20-00  
Hitachi Tower  
Singapore 049318  
Tel: 535-2100  
Fax: 535-1533

Hitachi Asia Ltd.  
Taipei Branch Office  
3F, Hung Kuo Building, No.167,  
Tun-Hwa North Road, Taipei (105)  
Tel: <886> (2) 2718-3666  
Fax: <886> (2) 2718-8180

Hitachi Asia (Hong Kong) Ltd.  
Group III (Electronic Components)  
7/F., North Tower, World Finance Centre,  
Harbour City, Canton Road, Tsim Sha Tsui,  
Kowloon, Hong Kong  
Tel: <852> (2) 735 9218  
Fax: <852> (2) 730 0281  
Telex: 40815 HITEC HX

Copyright © Hitachi, Ltd., 1998. All rights reserved. Printed in Japan.

---

## HM628128D Series

---

### Revision Record

Rev.	Date	Contents of Modification	Drawn by	Approved by
0.0	Jan. 20, 1999	Initial issue		

---

This datasheet has been downloaded from:

[www.DatasheetCatalog.com](http://www.DatasheetCatalog.com)

Datasheets for electronic components.



LittleDiode supplies new, hard to find or obsolete electronic components and semiconductors all over the world.

With over two million different components listed you are sure to find the part you need.

Feel free to visit us today at our online store:

[LittleDiode.com](http://LittleDiode.com)

Looking forward to providing you with the best possible service.