

---

# HM658512A Series

4 M PSRAM (512-kword × 8-bit)  
2 k Refresh

# HITACHI

ADE-203-218C(Z)  
Rev. 3.0  
Nov. 1997

---

## Description

The Hitachi HM658512A is a CMOS pseudo static RAM organized 512-kword × 8-bit. It realizes higher density, higher performance and low power consumption by employing 0.8 μm Hi-CMOS process technology.

It offers low power data retention by self refresh mode. It also offers easy non multiplexed address interface and easy refresh functions. HM658512A is suitable for handy systems which work with battery back-up systems.

The device is packaged in a small 525-mil SOP (460-mil body SOP) or a 8 × 20 mm TSOP with thickness of 1.2 mm, or a 600-mil plastic DIP. High density custom cards made of Tape Carrier Packages are also available.

## Features

- Single 5 V (±10%)
- High speed
  - Access time  
     $\overline{\text{CE}}$  access time: 70/80/100 ns (max)
  - Cycle time  
    Random read/write cycle time:  
    115/130/160 ns (min)
- Low power
  - Active: 250 mW (typ)
  - Standby: 200 μW (typ)
- Directly TTL compatible  
All inputs and outputs
- Simple address configuration  
Non multiplexed address
- Refresh cycle
  - 2048 refresh cycles: 32 ms

---

## HM658512A Series

---

- Easy refresh functions
  - Address refresh
  - Automatic refresh
  - Self refresh

### Ordering Information

Type No.	Access time	Package
HM658512ALP-7	70 ns	600-mil 32-pin plastic DIP (DP-32)
HM658512ALP-8	80 ns	
HM658512ALP-10	100 ns	
HM658512ALP-7V	70 ns	
HM658512ALP-8V	80 ns	
HM658512ALP-10V	100 ns	
HM658512ALFP-7	70 ns	525-mil 32-pin plastic SOP (FP-32D)
HM658512ALFP-8	80 ns	
HM658512ALFP-10	100 ns	
HM658512ALFP-7V	70 ns	
HM658512ALFP-8V	80 ns	
HM658512ALFP-10V	100 ns	
HM658512ALTT-7	70 ns	400-mil 32-pin plastic TSOP (TTP-32D)
HM658512ALTT-8	80 ns	
HM658512ALTT-10	100 ns	
HM658512ALTT-7V	70 ns	
HM658512ALTT-8V	80 ns	
HM658512ALTT-10V	100 ns	
HM658512ALRR-7	70 ns	400-mil 32-pin plastic TSOP (TTP-32DR)
HM658512ALRR-8	80 ns	
HM658512ALRR-10	100 ns	
HM658512ALRR-7V	70 ns	
HM658512ALRR-8V	80 ns	
HM658512ALRR-10V	100 ns	

---

Pin Arrangement

HM658512ALP/ALFP Series

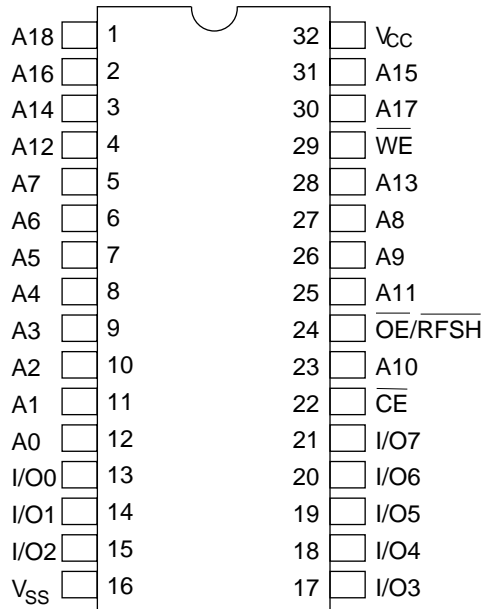

(Top view)

HM658512ALTT Series

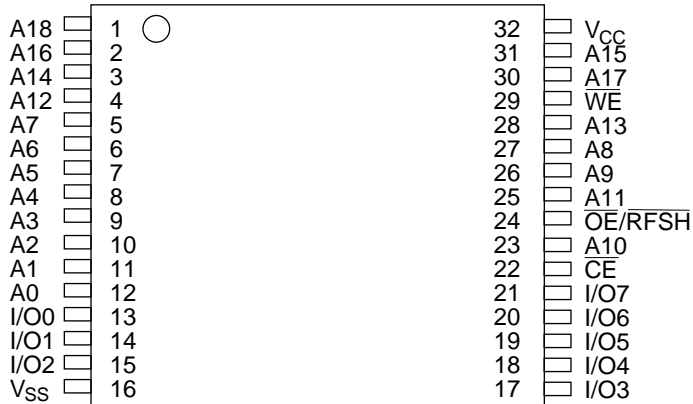

(Top view)

# HM658512A Series

## Pin Arrangement (cont.)

HM658512ALRR Series

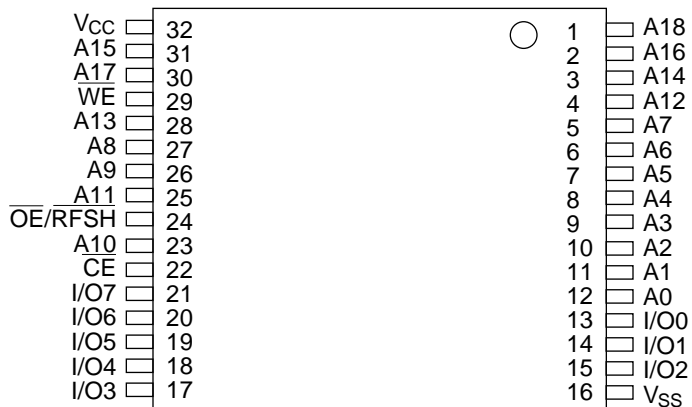

(Top view)

## Pin Description

Pin name	Function
A0 to A18	Address
I/O0 to I/O7	Input/Output
$\overline{CE}$	Chip enable
$\overline{OE/RFSH}$	Output enable/Refresh
$\overline{WE}$	Write enable
V <sub>CC</sub>	Power supply
V <sub>SS</sub>	Ground

Block Diagram

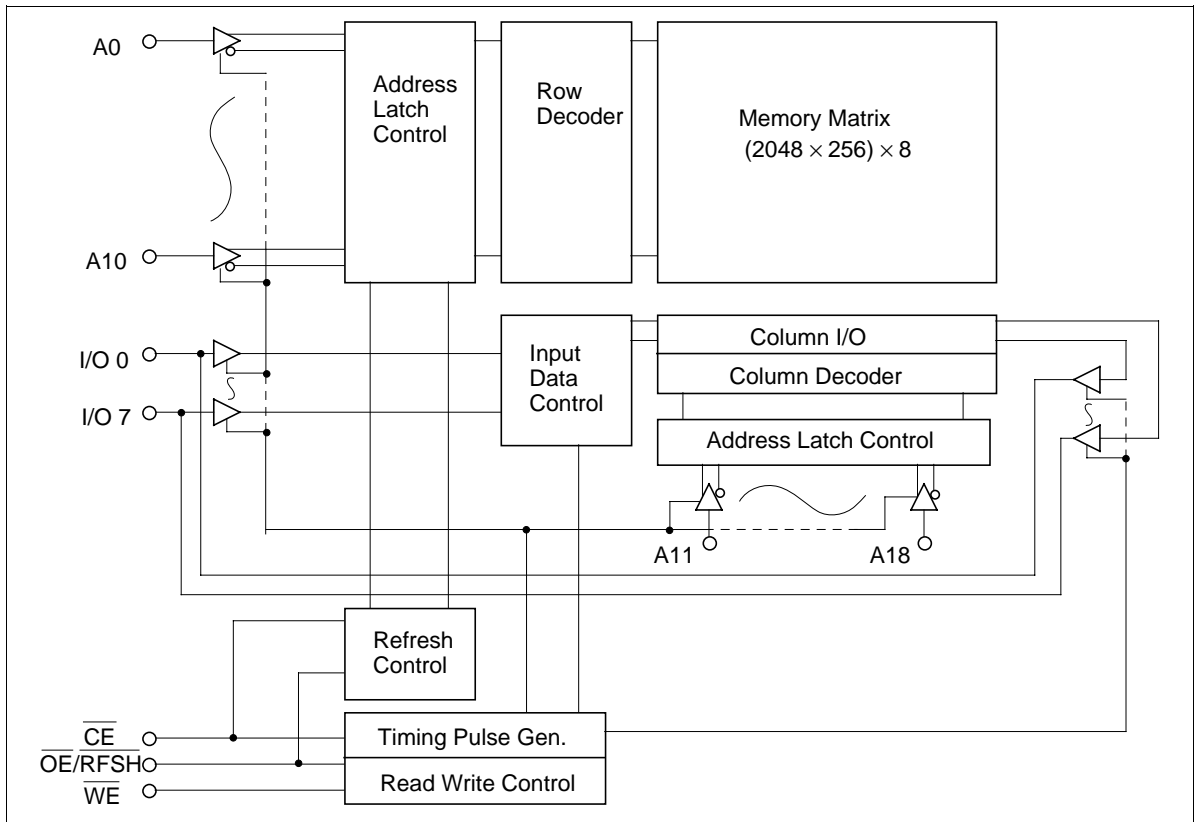

## Pin Functions

$\overline{\text{CE}}$ : Chip Enable (Input)

$\overline{\text{CE}}$  is a basic clock. RAM is active when  $\overline{\text{CE}}$  is low, and is on standby when  $\overline{\text{CE}}$  is high.

A0 to A18: Address Inputs (Input)

A0 to A10 are row addresses and A11 to A18 are column addresses. The entire addresses A0 to A18 are fetched into RAM by the falling edge of  $\overline{\text{CE}}$ .

$\overline{\text{OE/RFSH}}$ : Output Enable/Refresh (Input)

This pin has two functions. Basically it works as  $\overline{\text{OE}}$  when  $\overline{\text{CE}}$  is low, and as  $\overline{\text{RFSH}}$  when  $\overline{\text{CE}}$  is high (in standby mode). After a read or write cycle finishes, refresh does not start if  $\overline{\text{CE}}$  goes high while  $\overline{\text{OE/RFSH}}$  is held low. In order to start a refresh in standby mode,  $\overline{\text{OE/RFSH}}$  must go high to reset the refresh circuits of the RAM. After the refresh circuits are reset, the refresh starts when  $\overline{\text{OE/RFSH}}$  goes low.

I/O0 to I/O7: Input/Output (Inputs and Outputs) These pins are data I/O pins.

$\overline{\text{WE}}$ : Write Enable (Input)

RAM is in write mode when  $\overline{\text{WE}}$  is low, and is in read mode when  $\overline{\text{WE}}$  is high. I/O data is fetched into RAM by the rising edge of  $\overline{\text{WE}}$  or  $\overline{\text{CE}}$  (earlier timing) and the data is written into memory cells.

## Refresh

There are three refresh modes : address refresh, automatic refresh and self refresh.

- (1) Address refresh: Data is refreshed by accessing all 2048 row addresses every 32 ms. A read is one method of accessing those addresses. Each row address (2048 addresses of A0 to A10) must be read at least once every 32 ms. In address refresh mode,  $\overline{\text{OE/RFSH}}$  can remain high. In this case, the I/O pins remain at high impedance, but the refresh is done within RAM.
- (2) Automatic refresh: Instead of address refresh, automatic refresh can be used. RAM goes to automatic refresh mode if  $\overline{\text{OE/RFSH}}$  falls while  $\overline{\text{CE}}$  is high and it remains low for at least  $t_{\text{FAP}}$ . One automatic refresh cycle is executed by one low pulse of  $\overline{\text{OE/RFSH}}$ . It is not necessary to input the refresh address from outside since it is generated internally by an on-chip address counter. 2048 automatic refresh cycles must be done every 32 ms.
- (3) Self refresh: Self refresh mode is suitable for data retention by battery. In standby mode, a self refresh starts automatically when  $\overline{\text{OE/RFSH}}$  stays low for more than 8  $\mu\text{s}$ . Refresh addresses are automatically specified by the on-chip address counter, and the refresh period is determined by the on-chip timer.

Automatic refresh and self refresh are distinguished from each other by the width of the  $\overline{\text{OE/RFSH}}$  low pulse in standby mode. If the  $\overline{\text{OE/RFSH}}$  low pulse is wider than 8  $\mu\text{s}$ , RAM becomes into self refresh mode; if the  $\overline{\text{OE/RFSH}}$  low pulse is less than 8  $\mu\text{s}$ , it is recognized as an automatic refresh instruction.

At the end of self refresh, refresh reset time ( $t_{RFS}$ ) is required to reset the internal self refresh operation of the RAM. During  $t_{RFS}$ ,  $\overline{CE}$  and  $\overline{OE/RFSH}$  must be kept high. If auto refresh follows self refresh, low transition of  $\overline{OE/RFSH}$  at the beginning of automatic refresh must not occur during  $t_{RFS}$  period.

## Notes on Using the HM658512A

Since pseudo static RAM consists of dynamic circuits like DRAM, its clock pins are more noise-sensitive than conventional SRAM's.

- (1) If a short  $\overline{CE}$  pulse of a width less than  $t_{CE\ min}$  is applied to RAM, an incomplete read occurs and stored data may be destroyed. Make sure that  $\overline{CE}$  low pulses of less than  $t_{CE\ min}$  are inhibited. Note that a 10 ns  $\overline{CE}$  low pulse may sometimes occur owing to the gate delay on the board if the  $\overline{CE}$  signal is generated by the decoding of higher address signals on the board. Avoid these short pulses.
- (2)  $\overline{OE/RFSH}$  works as refresh control in standby mode. A short  $\overline{OE/RFSH}$  low pulse may cause an incomplete refresh that will destroy data. Make sure that  $\overline{OE/RFSH}$  low pulse of less than  $t_{FAP\ min}$  are also inhibited.
- (3)  $t_{OHC}$  and  $t_{OCD}$  are the timing specs which distinguish the  $\overline{OE}$  function of  $\overline{OE/RFSH}$  from the  $\overline{RFSH}$  function. The  $t_{OHC}$  and  $t_{OCD}$  specs must be strictly maintained.
- (4) Start the HM658512A operating by executing at least eight initial cycles (dummy cycles) at least 100  $\mu$ s after the power voltage reaches 4.5 V-5.5 V after power-on.

## Function Table

$\overline{CE}$	$\overline{OE/RFSH}$	$\overline{WE}$	I/O pin	Mode
L	L	H	Dout	Read
L	X	L	High-Z	Write
L	H	H	High-Z	—
H	L	X	High-Z	Refresh
H	H	X	High-Z	Standby

Note: X means H or L.

---

## HM658512A Series

---

### Absolute Maximum Ratings

Parameter	Symbol	Value	Unit	Note
Terminal voltage with respect to $V_{SS}$	$V_T$	-1.0 to +7.0	V	1
Power dissipation	$P_T$	1.0	W	
Operating temperature	$T_{opr}$	0 to +70	°C	
Storage temperature	$T_{stg}$	-55 to +125	°C	
Storage temperature under bias	$T_{bias}$	-10 to +85	°C	

Note: 1. With respect to  $V_{SS}$

### Recommended DC Operating Conditions ( $T_a = 0$ to +70°C)

Parameter	Symbol	Min	Typ	Max	Unit	Notes
Supply voltage	$V_{CC}$	4.5	5.0	5.5	V	
	$V_{SS}$	0	0	0	V	
Input voltage	$V_{IH}$	2.4	—	6.0	V	
	$V_{IL}$	-1.0	—	0.8	V	1

Note: 1.  $V_{IL}$  min = -3.0 V for pulse width 30 ns

**DC Characteristics** ( $T_a = 0$  to  $+70^\circ\text{C}$ ,  $V_{CC} = 5\text{ V} \pm 10\%$ ,  $V_{SS} = 0\text{ V}$ )

Parameter	Symbol	Min	Typ	Max	Unit	Test conditions	Notes
Operating power supply current	$I_{CC1}$	—	—	75	mA	$I_{I/O} = 0\text{ mA}$ $t_{cyc} = \text{min}$	
Standby power supply current	$I_{SB1}$	—	1	2	mA	$\overline{CE} = V_{IH}$ , $V_{in} \geq 0\text{ V}$ $\overline{OE}/\text{RFSH} = V_{IH}$	
	$I_{SB2}$	—	20	200	$\mu\text{A}$	$\overline{CE} \geq V_{CC} - 0.2\text{ V}$ , $V_{in} \geq 0\text{ V}$ , 1 $\overline{OE}/\text{RFSH} \geq V_{CC} - 0.2\text{ V}$	
					$\mu\text{A}$	$\overline{CE} \geq V_{CC} - 0.2\text{ V}$ , $V_{in} \geq 0\text{ V}$ , 2 $\overline{OE}/\text{RFSH} \geq V_{CC} - 0.2\text{ V}$	
Operating power supply current in self refresh mode	$I_{CC2}$	—	1	2	mA	$\overline{CE} = V_{IH}$ , $V_{in} \geq 0\text{ V}$ , $\overline{OE}/\text{RFSH} = V_{IL}$	
	$I_{CC3}$	—	70	200	$\mu\text{A}$	$\overline{CE} \geq V_{CC} - 0.2\text{ V}$ , $V_{in} \geq 0\text{ V}$ , 1 $\overline{OE}/\text{RFSH} \leq 0.2\text{ V}$	
					$\mu\text{A}$	$\overline{CE} \geq V_{CC} - 0.2\text{ V}$ , $V_{in} \geq 0\text{ V}$ , 2 $\overline{OE}/\text{RFSH} \leq 0.2\text{ V}$	
Input leakage current	$I_{LI}$	-10	—	10	$\mu\text{A}$	$V_{CC} = 5.5\text{ V}$ , $V_{in} = V_{SS}$ to $V_{CC}$	
Output leakage current	$I_{LO}$	-10	—	10	$\mu\text{A}$	$\overline{OE}/\text{RFSH} = V_{IH}$ $V_{I/O} = V_{SS}$ to $V_{CC}$	
Output voltage	$V_{OL}$	—	—	0.4	V	$I_{OL} = 2.1\text{ mA}$	
	$V_{OH}$	2.4	—	—	V	$I_{OH} = -1\text{ mA}$	

Notes: 1. Only for L-version.

2. Only for V-version.

**Capacitance** ( $T_a = 25^\circ\text{C}$ ,  $f = 1\text{ MHz}$ )

Parameter	Symbol	Typ	Max	Unit	Test conditions
Input capacitance	$C_{in}$	—	8	pF	$V_{in} = 0\text{ V}$
Input/output capacitance	$C_{I/O}$	—	10	pF	$V_{I/O} = 0\text{ V}$

Note : This parameter is sampled and not 100% tested.

# HM658512A Series

**AC Characteristics** ( $T_a = 0$  to  $+70^\circ\text{C}$ ,  $V_{CC} = 5\text{ V} \pm 10\%$ , unless otherwise noted.)

## Test Conditions

- Input pulse levels: 0.4 V, 2.4 V
- Input rise and fall time: 5 ns
- Timing measurement level: 0.8 V, 2.2 V
- Reference levels:  $V_{OH} = 2.0\text{ V}$ ,  $V_{OL} = 0.8\text{ V}$
- Output load: 1 TTL Gate and  $C_L$  (100 pF) (Including scope and jig)

		HM658512A							
		-7		-8		-10			
Parameter	Symbol	Min	Max	Min	Max	Min	Max	Unit	Notes
Random read or write cycle time	$t_{RC}$	115	—	130	—	160	—	ns	
Chip enable access time	$t_{CEA}$	—	70	—	80	—	100	ns	
Read-modify- write cycle time	$t_{RWC}$	160	—	180	—	220	—	ns	
Output enable access time	$t_{OEA}$	—	25	—	30	—	40	ns	
Chip disable to output in high-Z	$t_{CHZ}$	0	25	0	25	0	25	ns	1, 2
Chip enable to output in low-Z	$t_{CLZ}$	20	—	20	—	20	—	ns	2
Output disable to output in high-Z	$t_{OHZ}$	—	25	—	25	—	25	ns	1, 2
Output enable to output in low-Z	$t_{OLZ}$	0	—	0	—	0	—	ns	2
Chip enable pulse width	$t_{CE}$	70 n	10 $\mu$	80 n	10 $\mu$	100 n	10 $\mu$	s	
Chip enable precharge time	$t_P$	35	—	40	—	50	—	ns	
Address setup time	$t_{AS}$	0	—	0	—	0	—	ns	
Address hold time	$t_{AH}$	20	—	20	—	25	—	ns	
Read command setup time	$t_{RCS}$	0	—	0	—	0	—	ns	
Read command hold time	$t_{RCH}$	0	—	0	—	0	—	ns	
Write command pulse width	$t_{WP}$	25	—	25	—	30	—	ns	
Chip enable to end of write	$t_{CW}$	70	—	80	—	100	—	ns	
Chip enable to output enable delay time	$t_{OCD}$	0	—	0	—	0	—	ns	
Output enable hold time	$t_{OHC}$	0	—	0	—	0	—	ns	

AC Characteristics (Ta = 0 to +70°C, V<sub>CC</sub> = 5 V ± 10%, unless otherwise noted.) (cont.)

Parameter	Symbol	HM658512A						Unit	Notes
		-7		-8		-10			
		Min	Max	Min	Max	Min	Max		
Data in to end of write	t <sub>DW</sub>	20	—	20	—	25	—	ns	
Data in hold time for write	t <sub>DH</sub>	0	—	0	—	0	—	ns	
Output active from end of write	t <sub>OW</sub>	5	—	5	—	5	—	ns	2
Write to output in high-Z	t <sub>WHZ</sub>	—	20	—	20	—	25	ns	1, 2
Transition time (rise and fall)	t <sub>T</sub>	3	50	3	50	3	50	ns	6
Refresh command delay time	t <sub>RFD</sub>	35	—	40	—	50	—	ns	
Refresh precharge time	t <sub>FP</sub>	35	—	40	—	40	—	ns	
Refresh command pulse width for automatic refresh	t <sub>FAP</sub>	70 n	8 μ	80 n	8 μ	80 n	8 μ	s	
Automatic refresh cycle time	t <sub>FC</sub>	115	—	130	—	160	—	ns	
Refresh command pulse width for self refresh	t <sub>FAS</sub>	8	—	8	—	8	—	μs	
Refresh reset time from self refresh	t <sub>RFS</sub>	600	—	600	—	600	—	ns	9
Refresh period	t <sub>REF</sub>	—	32	—	32	—	32	ms	2048 cycle

- Notes:
1. t<sub>CHZ</sub>, t<sub>OHZ</sub>, t<sub>WHZ</sub> are defined as the time at which the output achieves the open circuit condition.
  2. t<sub>CHZ</sub>, t<sub>CLZ</sub>, t<sub>OHZ</sub>, t<sub>OLZ</sub>, t<sub>WHZ</sub> and t<sub>OW</sub> are sampled under the condition of t<sub>r</sub> = 5 ns and not 100% tested.
  3. A write occurs during the overlap of low  $\overline{CE}$  and low  $\overline{WE}$ . Write end is defined at the earlier of  $\overline{WE}$  going high or  $\overline{CE}$  going high.
  4. If the  $\overline{CE}$  low transition occurs simultaneously with or from the  $\overline{WE}$  low transition, the output buffers remain in high impedance state.
  5. In write cycle,  $\overline{OE}$  or  $\overline{WE}$  must disable output buffers prior to applying data to the device and at the end of write cycle data inputs must be floated prior to  $\overline{OE}$  or  $\overline{WE}$  turning on output buffers. During this period, I/O pins are in the output state, therefore the input signals of opposite phase to the outputs must not be applied.
  6. Transition time t<sub>T</sub> is measured between V<sub>IH</sub> (min) and V<sub>IL</sub> (max). V<sub>IH</sub> (min) and V<sub>IL</sub> (max) are reference levels for measuring timing of input signals.
  7. After power-up, pause for more than 100 μs and execute at least 8 initialization cycles.
  8. 2048 cycles of burst refresh or the first cycle of distributed automatic refresh must be executed within 15 μs after self refresh, in order to meet the refresh specification of 32 ms and 2048 cycles.
  9. At the end of self refresh, refresh reset time (t<sub>RFS</sub>) is required to reset the internal self refresh operation of the RAM. During t<sub>RFS</sub>,  $\overline{CE}$  and  $\overline{OE/RFSH}$  must be kept high. If automatic refresh follows self refresh, low transition of  $\overline{OE/RFSH}$  at the beginning of automatic refresh must not occur during t<sub>RFS</sub> period.

## Timing Waveform

### Read Cycle

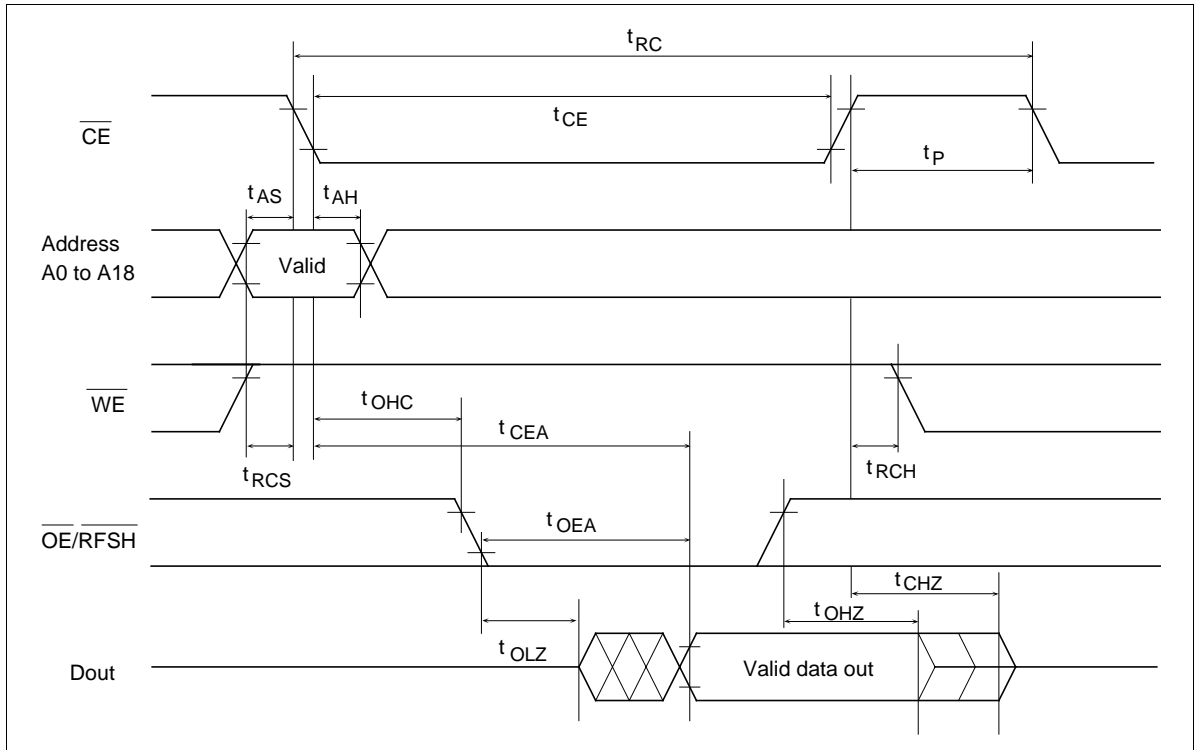

Write Cycle (1) ( $\overline{OE}$  high)

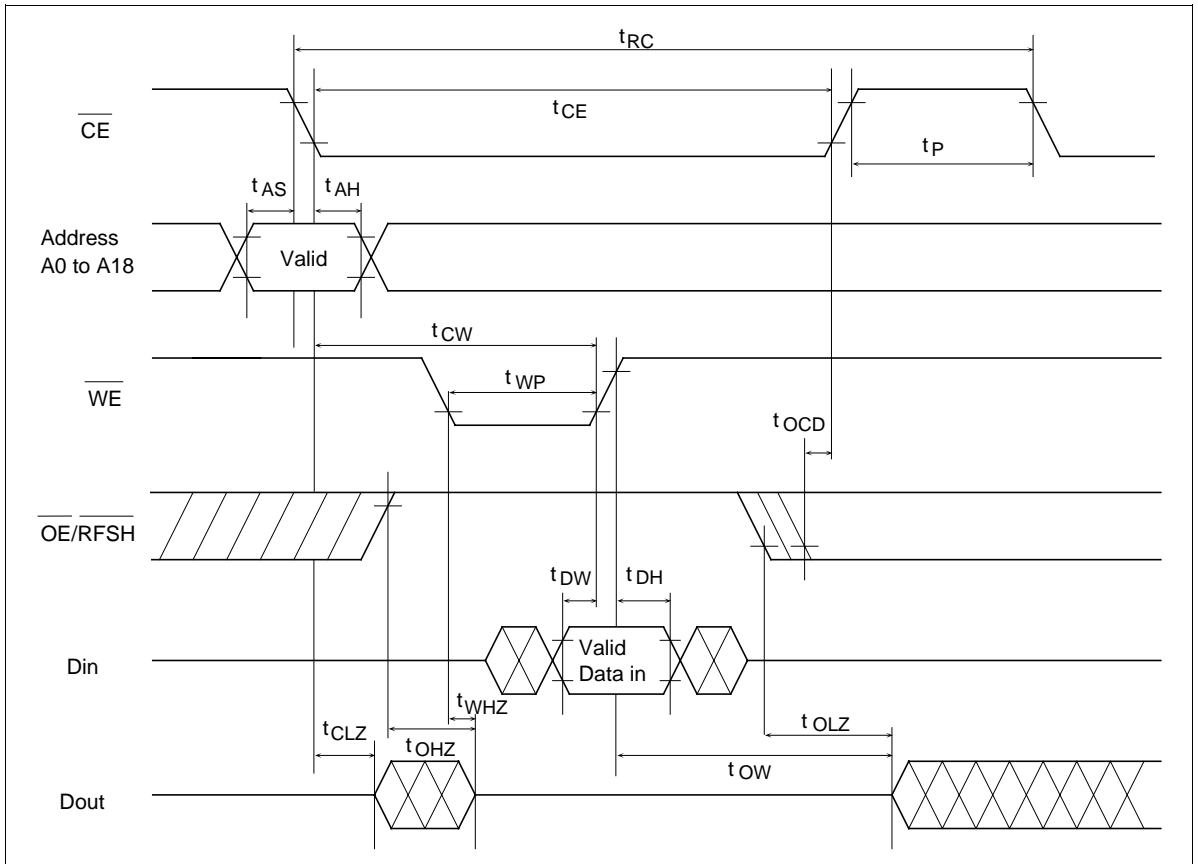

## Write Cycle (2) ( $\overline{OE}$ low)

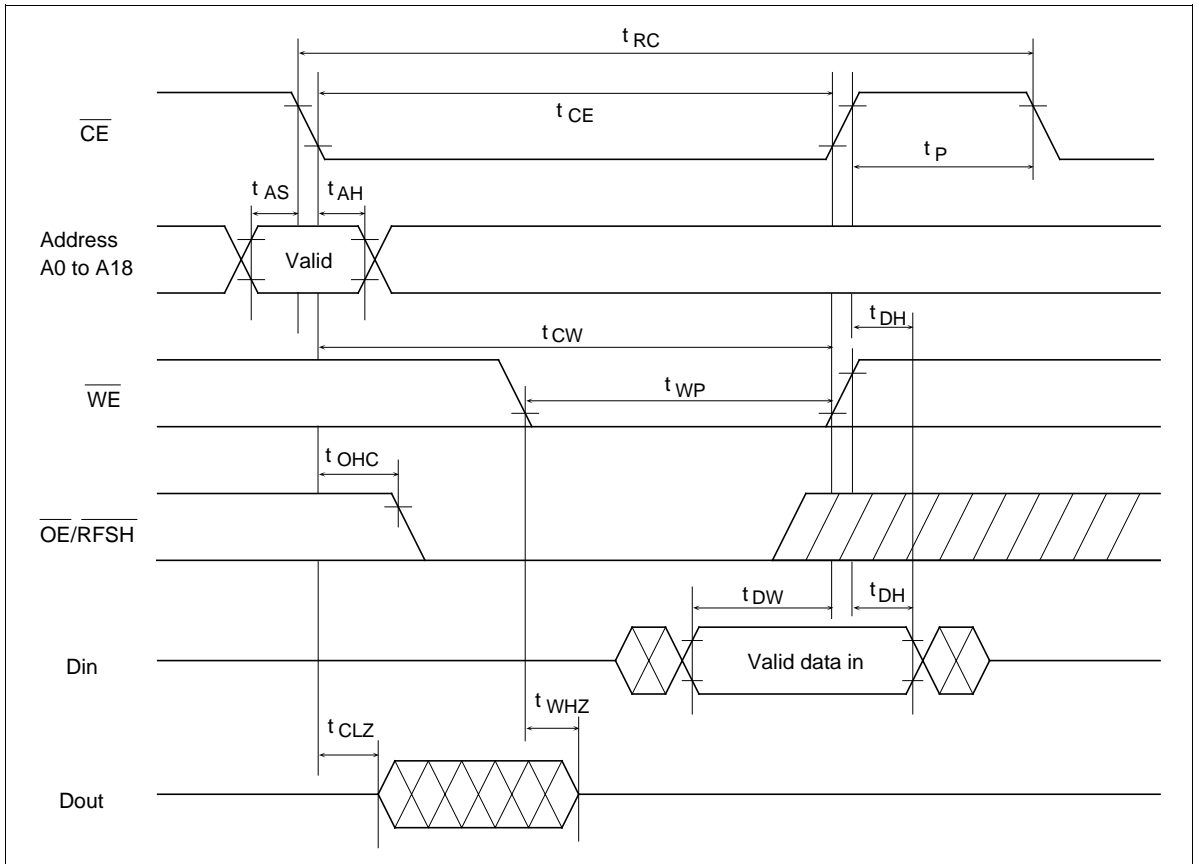

Read-Modify-Write Cycle

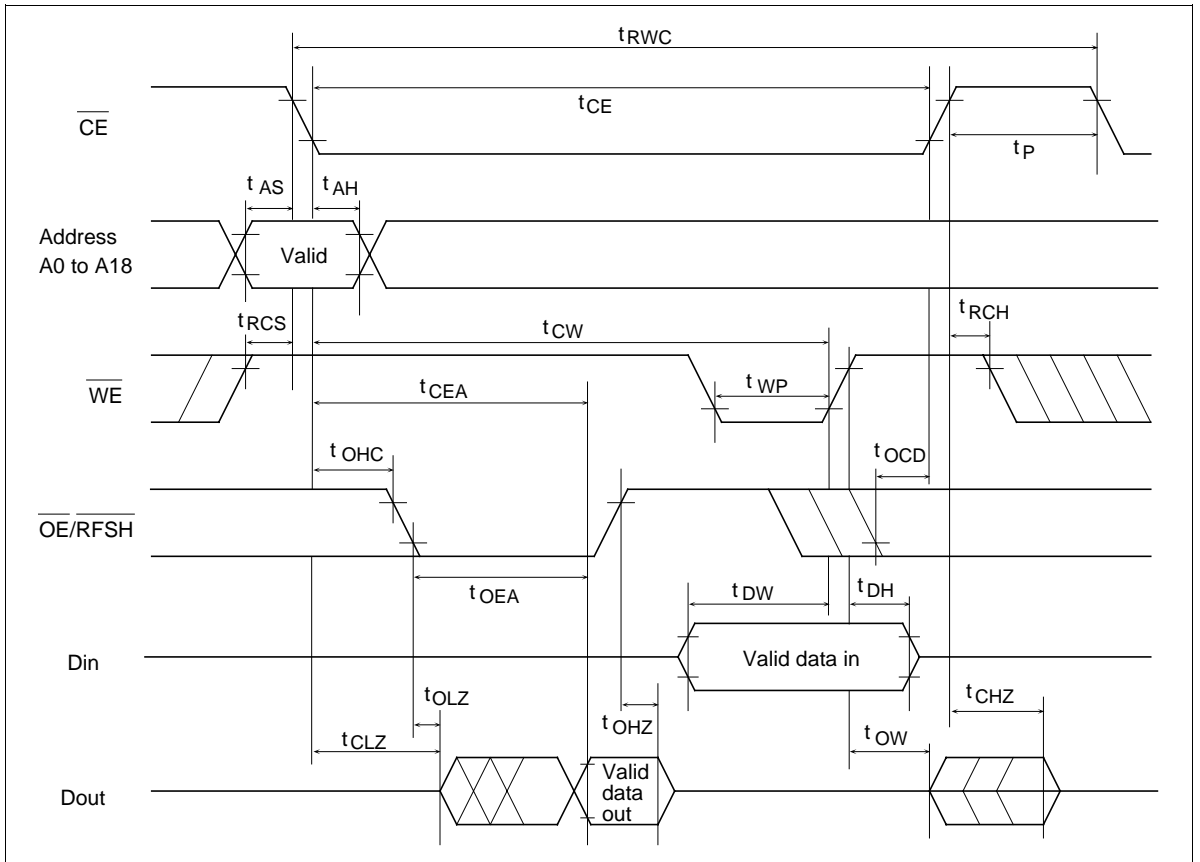

Automatic Refresh Cycle

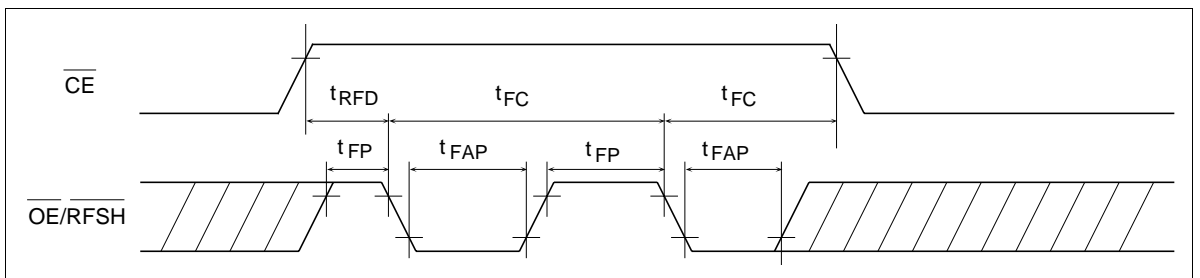

## Self Refresh Cycle

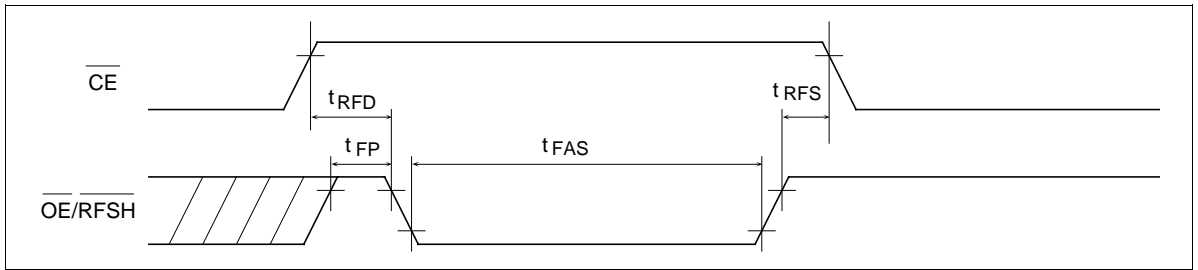

## Low $V_{CC}$ Data Retention Characteristics ( $T_a = 0$ to $+70^\circ\text{C}$ )

This characteristics is guaranteed only for V-version.

Parameter	Symbol	Min	Typ	Max	Unit	Test conditions
$V_{CC}$ for data retention	$V_{DR}$	3.0	—	5.5	V	
Self refresh current	$I_{CCDR}$	—	—	50	$\mu\text{A}$	$V_{CC} = 3.0\text{ V}$ , $\overline{CE} \geq V_{CC} - 0.2\text{ V}$ $\overline{OE/RFSH} \leq 0.2$ $V_{in} \geq 0\text{ V}$
		—	—	100	$\mu\text{A}$	$V_{CC} = 5.5\text{ V}$ , $\overline{CE} \geq V_{CC} - 0.2\text{ V}$ $\overline{OE/RFSH} \leq 0.2$ $V_{in} \geq 0\text{ V}$
Refresh setup time	$t_{FS}$	0	—	—	ns	
Operation recovery time	$t_{FR}$	5	—	—	ms	

Low  $V_{CC}$  Data Retention Timing Waveform

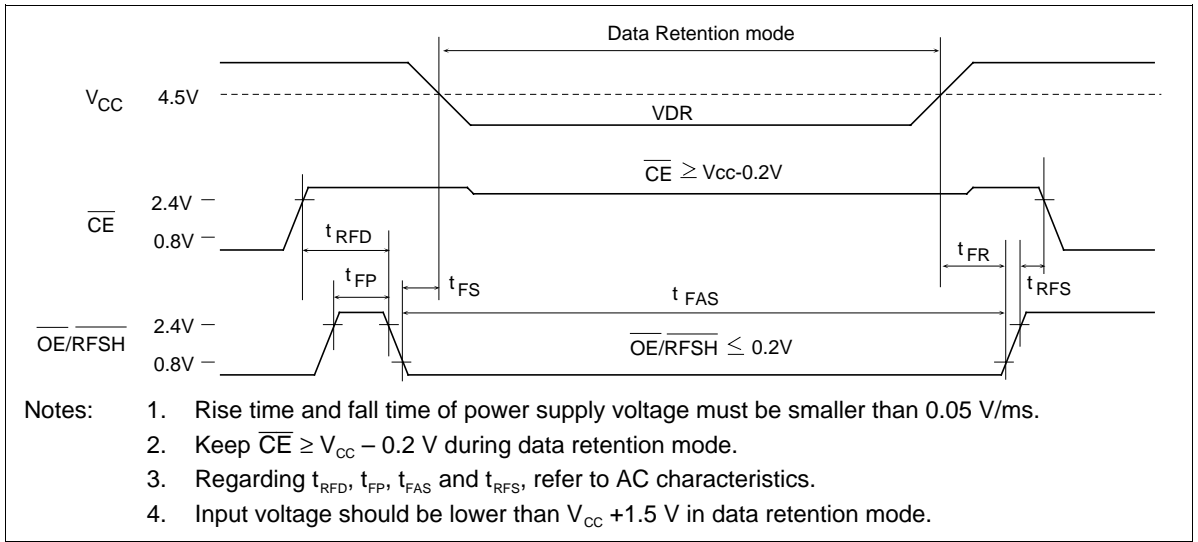

# HM658512A Series

## Package Dimensions

### HM658512ALP Series (DP-32)

Unit: mm

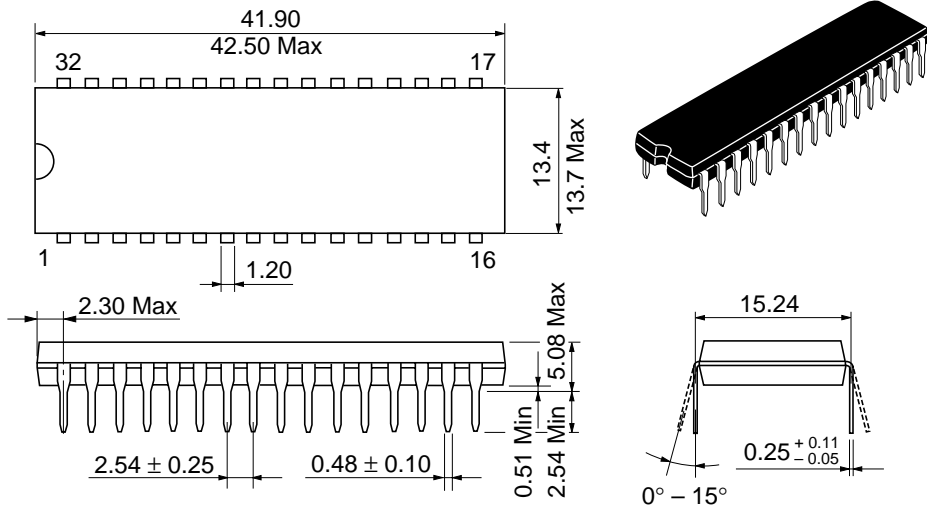

Hitachi Code	DP-32
JEDEC	—
EIAJ	Conforms
Weight (reference value)	5.1 g

HM658512ALFP Series (FP-32D)

Unit: mm

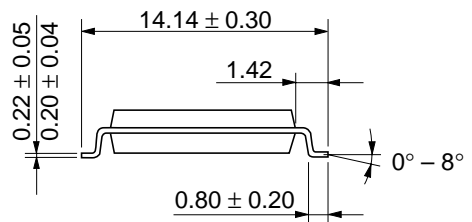
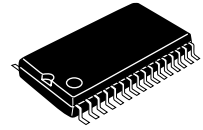
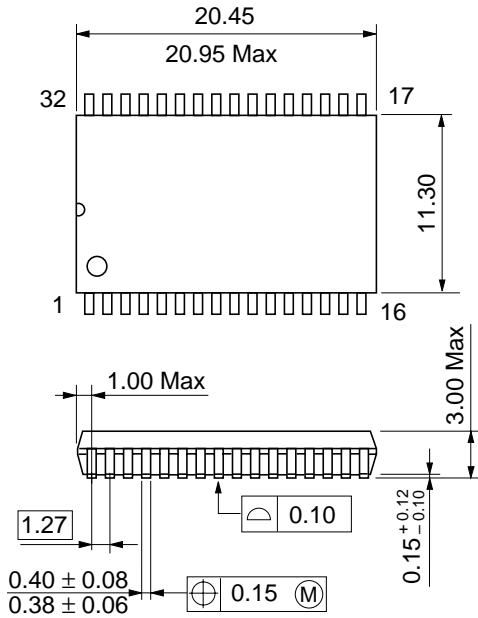

Dimension including the plating thickness  
Base material dimension

Hitachi Code	FP-32D
JEDEC	Conforms
EIAJ	—
Weight (reference value)	1.3 g

# HM658512A Series

## HM658512ALTT Series (TTP-32D)

Unit: mm

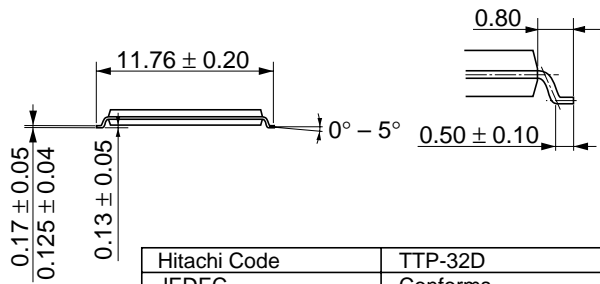
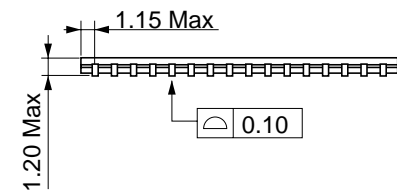
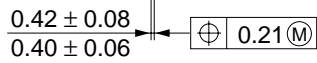
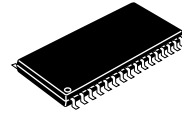
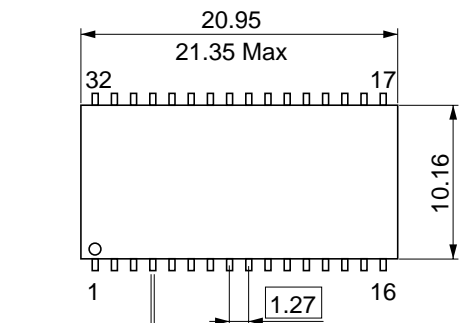

Dimension including the plating thickness  
Base material dimension

Hitachi Code	TTP-32D
JEDEC	Conforms
EIAJ	—
Weight (reference value)	0.51 g

HM658512ALRR Series (TTP-32DR)

Unit: mm

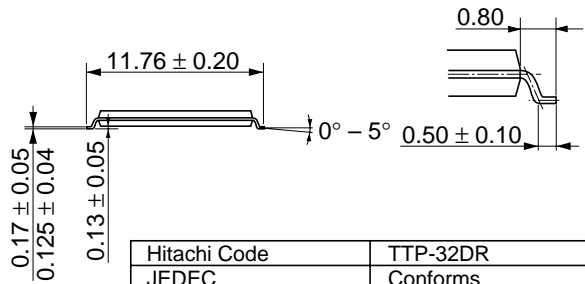
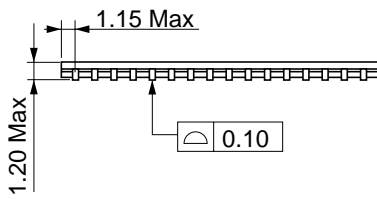
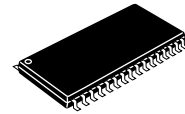
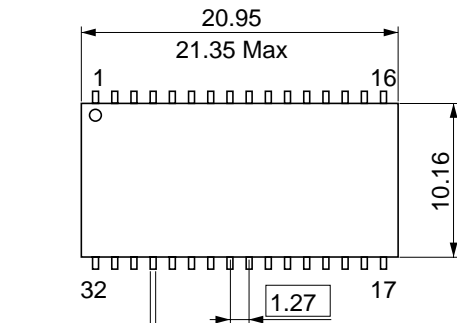

Dimension including the plating thickness  
Base material dimension

Hitachi Code	TTP-32DR
JEDEC	Conforms
EIAJ	—
Weight (reference value)	0.51 g

When using this document, keep the following in mind:

1. This document may, wholly or partially, be subject to change without notice.
2. All rights are reserved: No one is permitted to reproduce or duplicate, in any form, the whole or part of this document without Hitachi's permission.
3. Hitachi will not be held responsible for any damage to the user that may result from accidents or any other reasons during operation of the user's unit according to this document.
4. Circuitry and other examples described herein are meant merely to indicate the characteristics and performance of Hitachi's semiconductor products. Hitachi assumes no responsibility for any intellectual property claims or other problems that may result from applications based on the examples described herein.
5. No license is granted by implication or otherwise under any patents or other rights of any third party or Hitachi, Ltd.
6. **MEDICAL APPLICATIONS:** Hitachi's products are not authorized for use in **MEDICAL APPLICATIONS** without the written consent of the appropriate officer of Hitachi's sales company. Such use includes, but is not limited to, use in life support systems. Buyers of Hitachi's products are requested to notify the relevant Hitachi sales offices when planning to use the products in **MEDICAL APPLICATIONS**.

# HITACHI

## Hitachi, Ltd.

Semiconductor & IC Div.  
Nippon Bldg., 2-6-2, Ohte-machi, Chiyoda-ku, Tokyo 100-0004, Japan  
Tel: Tokyo (03) 3270-2111  
Fax: (03) 3270-5109

### For further information write to:

Hitachi Semiconductor  
(America) Inc.  
2000 Sierra Point Parkway  
Brisbane, CA. 94005-1897  
U S A  
Tel: 800-285-1601  
Fax:303-297-0447

Hitachi Europe GmbH  
Continental Europe  
Dornacher Straße 3  
D-85622 Feldkirchen  
München  
Tel: 089-9 91 80-0  
Fax: 089-9 29 30-00

Hitachi Europe Ltd.  
Electronic Components Div.  
Northern Europe Headquarters  
Whitebrook Park  
Lower Cookham Road  
Maidenhead  
Berkshire SL6 8YA  
United Kingdom  
Tel: 01628-585000  
Fax: 01628-585160

Hitachi Asia Pte. Ltd.  
16 Collyer Quay #20-00  
Hitachi Tower  
Singapore 049318  
Tel: 535-2100  
Fax: 535-1533

Hitachi Asia (Hong Kong) Ltd.  
Unit 706, North Tower,  
World Finance Centre,  
Harbour City, Canton Road  
Tsim Sha Tsui, Kowloon  
Hong Kong  
Tel: 27359218  
Fax: 27306071

Copyright © Hitachi, Ltd., 1998. All rights reserved. Printed in Japan.

This datasheet has been downloaded from:

[www.DatasheetCatalog.com](http://www.DatasheetCatalog.com)

Datasheets for electronic components.



LittleDiode supplies new, hard to find or obsolete electronic components and semiconductors all over the world.

With over two million different components listed you are sure to find the part you need.

Feel free to visit us today at our online store:

[LittleDiode.com](http://LittleDiode.com)

Looking forward to providing you with the best possible service.