

**HMA121A**

**HMA121B**

**HMA121C**

**DESCRIPTION**

The HMA121X series consists of a gallium arsenide infrared emitting diode driving a silicon phototransistor in a compact 4-pin mini-flat package. The lead pitch is 2.54 mm.

**FEATURES**

- Compact 4-pin package (2.4 mm maximum standoff height)
- Current Transfer Ratio: in selected groups  
HMA121A: 100-300%  
HMA121B: 50-150%  
HMA121C: 100-200%
- Available in tape and reel quantities of 500 and 2500.
- Applicable to Infrared Ray reflow (230°C max, 30 seconds.)
- U.L. (File # E90700), CSA (82858) and BSI (8611/8612) certified
- VDE certified (option V)
- Creepage ≥ 5 mm, typical 5.2 mm
- Clearance ≥ 5 mm, typical 5.2 mm

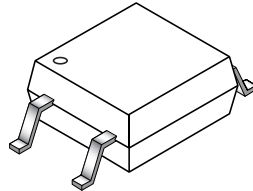

**APPLICATIONS**

- Digital logic inputs
- Microprocessor inputs
- Power supply monitor
- Twisted pair line receiver
- Telephone line receiver

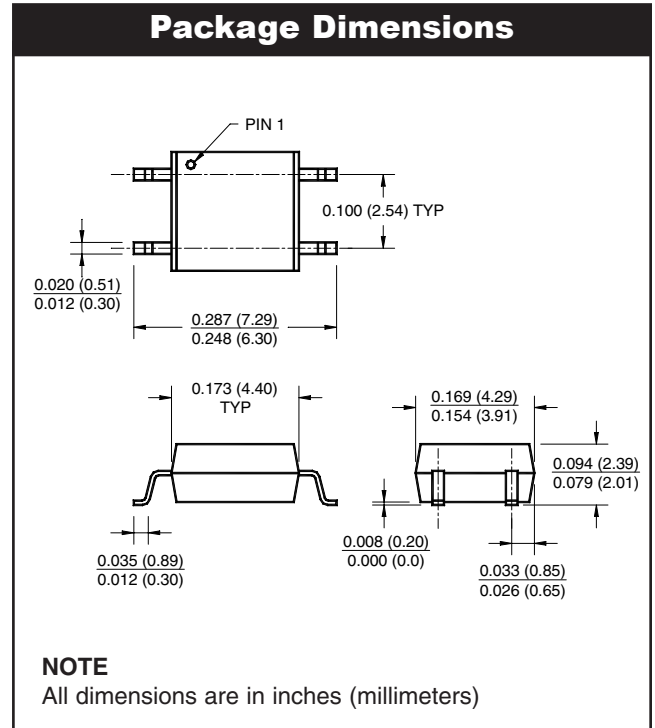
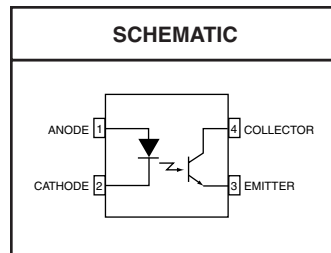

<b>ABSOLUTE MAXIMUM RATINGS</b> ( $T_A = 25^\circ\text{C}$ unless otherwise specified)			
Parameter	Symbol	Value	Units
<b>TOTAL PACKAGE</b>			
Storage Temperature	$T_{STG}$	-55 to +150	°C
Operating Temperature	$T_{OPR}$	-55 to +100	°C
<b>EMITTER</b>			
Continuous Forward Current	$I_F$ (avg)	50	mA
Peak Forward Current (1 $\mu\text{s}$ pulse, 300 pps.)	$I_F$ (pk)	1	A
Reverse Input Voltage	$V_R$	6	V
Power Dissipation	$P_D$	70	mW
Derate linearly (above 25°C)		0.65	mW/°C
<b>DETECTOR</b>			
Continuous Collector Current		80	mA
Power Dissipation	$P_D$	150	mW
Derate linearly (above 25°C)		2.0	mW/°C
Collector-Emitter Voltage	$V_{CEO}$	80	V
Emitter-Collector Voltage	$V_{ECO}$	7	V

**HMA121A**
**HMA121B**
**HMA121C**

ELECTRICAL CHARACTERISTICS (T <sub>A</sub> = 25°C)							
INDIVIDUAL COMPONENT CHARACTERISTICS							
Parameter	Test Conditions	Symbol	Device	Min	Typ**	Max	Unit
<b>EMITTER</b>							
Forward Voltage	(I <sub>F</sub> = 10 mA)	V <sub>F</sub>	ALL	1.0		1.3	V
Reverse Current	(V <sub>R</sub> = 5 V)	I <sub>R</sub>	ALL			5	μA
<b>DETECTOR</b>							
Breakdown Voltage Collector to Emitter	(I <sub>C</sub> = 1 mA, I <sub>F</sub> = 0)	BV <sub>CEO</sub>	ALL	80			V
Emitter to Collector	(I <sub>E</sub> = 100 μA, I <sub>F</sub> = 0)	BV <sub>ECO</sub>	All	7			
Collector Dark Current	(V <sub>CE</sub> = 40 V, I <sub>F</sub> = 0)	I <sub>CEO</sub>	All			100	nA
Capacitance	(V <sub>CE</sub> = 0 V, f = 1 MHz)	C <sub>CE</sub>	All		10		pF

TRANSFER CHARACTERISTICS (T <sub>A</sub> = 25°C)							
Characteristic	Test Conditions	Symbol	Device	Min	Typ**	Max	Unit
DC Current Transfer Ratio	(I <sub>F</sub> = 5 mA, V <sub>CE</sub> = 5 V)	CTR	HMA121A	100		300	%
			HMA121B	50		150	
			HMA121C	100		200	
Saturation Voltage	(I <sub>F</sub> = 8 mA, I <sub>C</sub> = 2.4 mA)	V <sub>CE (SAT)</sub>	ALL			0.4	V
Rise Time (Non-Saturated)	(I <sub>C</sub> = 2 mA, V <sub>CE</sub> = 5 V) (R <sub>L</sub> = 100Ω)	t <sub>r</sub>	ALL		3		μs
Fall Time (Non-Saturated)	(I <sub>C</sub> = 2 mA, V <sub>CE</sub> = 5 V) (R <sub>L</sub> = 100Ω)	t <sub>f</sub>	ALL		3		

ISOLATION CHARACTERISTICS							
Characteristic	Test Conditions	Symbol	Device	Min	Typ**	Max	Unit
Steady State Isolation Voltage	(1 Minute)	V <sub>ISO</sub>	All	3750			VRMS

 \*\* All typicals at T<sub>A</sub> = 25°C

**TYPICAL PERFORMANCE CURVES**

**Fig. 1 Forward Current vs. Forward Voltage**

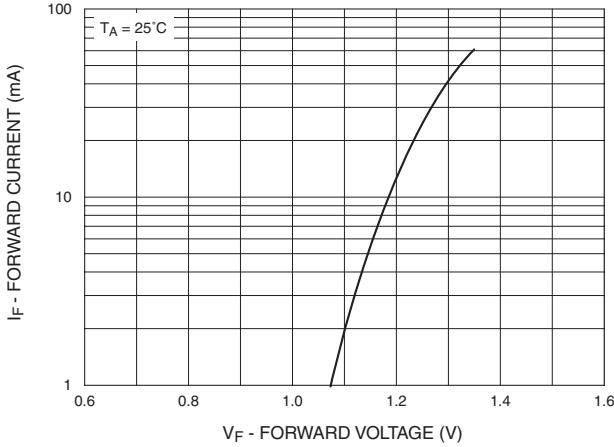

**Fig. 2 Collector Current vs. Forward Current**

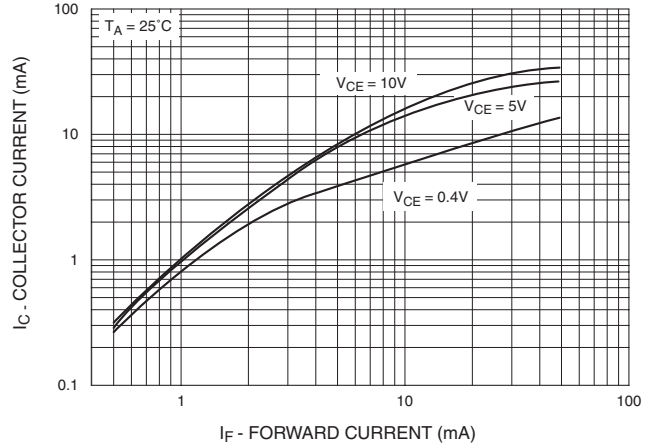

**Fig. 3 Current Transfer Ratio vs. Forward Current**

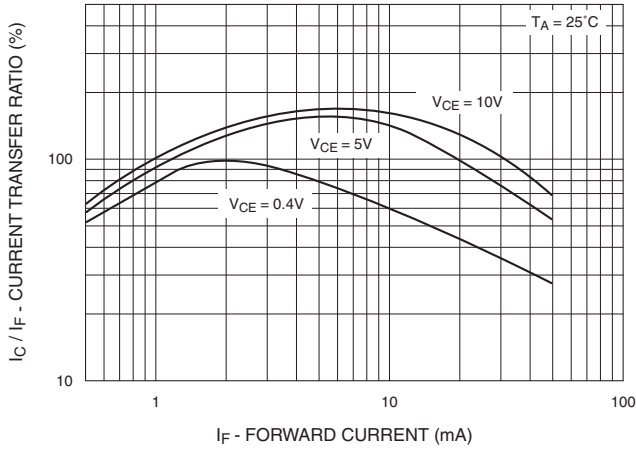

**Fig. 4 Collector Current vs. Temperature**

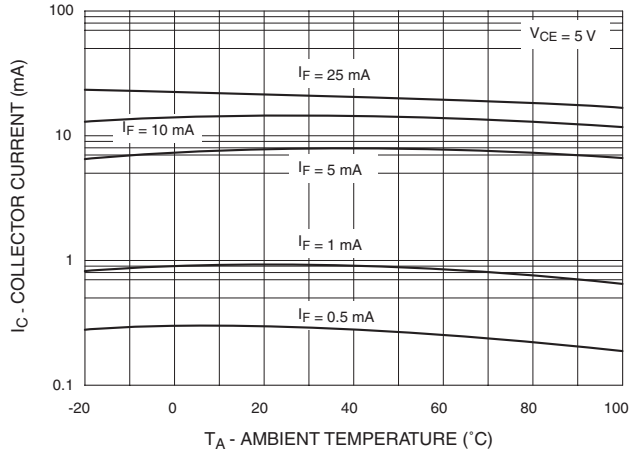

**Fig. 5 Collector Current vs. Collector-Emitter Voltage**

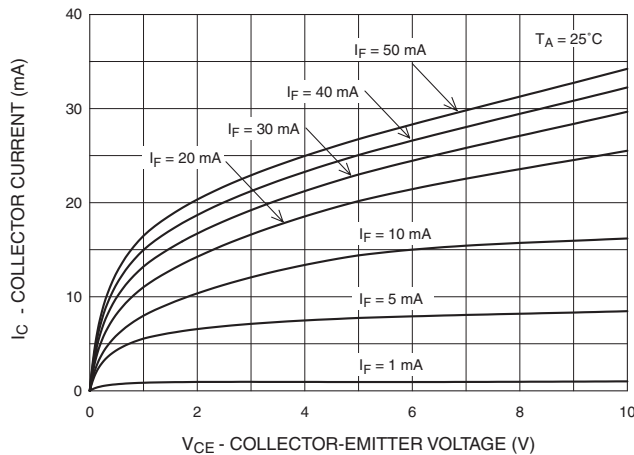

HMA121A

HMA121B

HMA121C

**Fig. 6 Collector Current vs. Collector-Emitter Voltage**

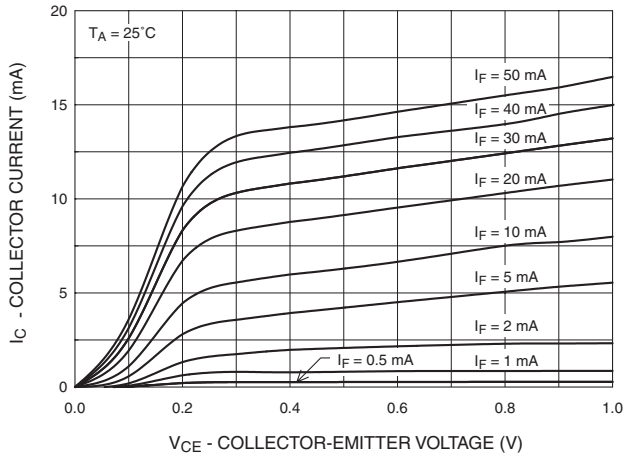

**Fig. 7 Collector Dark Current vs. Temperature**

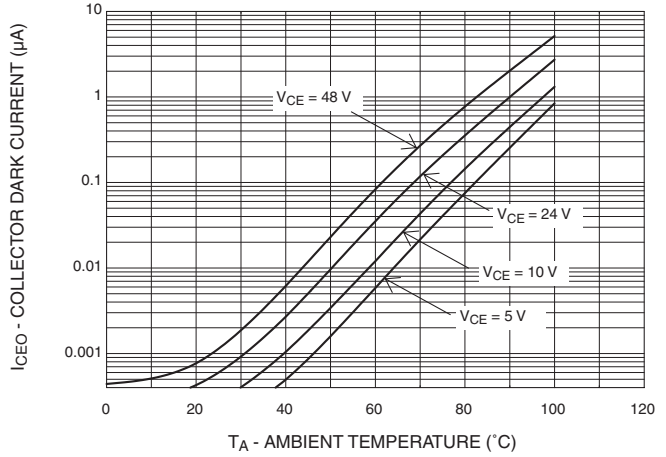

**Fig. 8 Switching Time vs. Load Resistance**

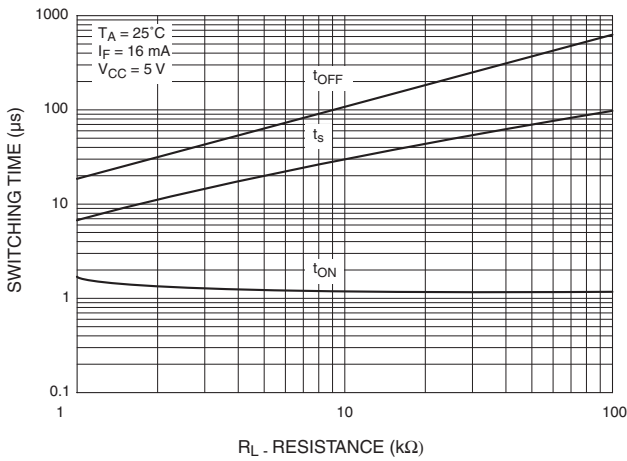

**Fig. 9 Collector-Emitter Saturation Voltage vs. Temperature**

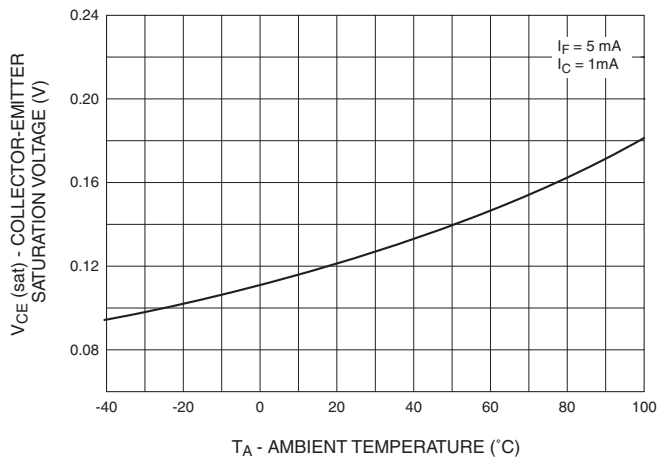

HMA121A

HMA121B

HMA121C

**ORDERING INFORMATION**

Option	Description
R1	Tape and Reel (500 Units)
R2	Tape and Reel (2500 Units)

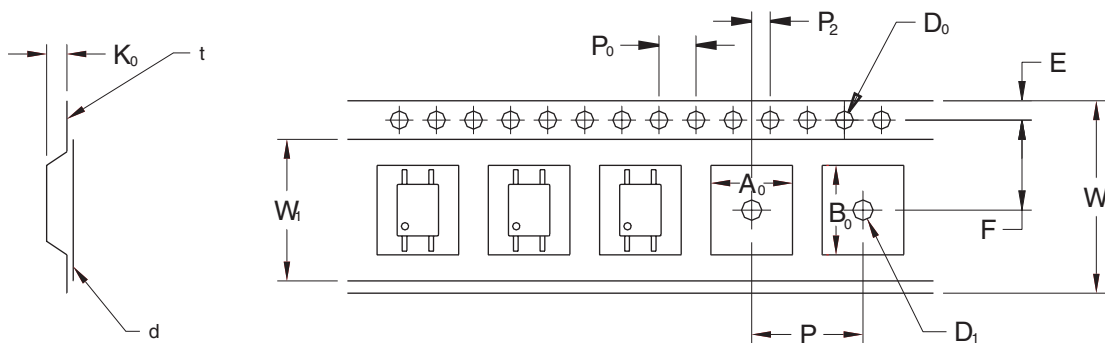

Description		Symbol	2.54 Pitch Dimensions (mm)
Tape Width		W	12.00±0.4
Tape Thickness		t	0.30±0.20
Sprocket Hole Pitch		$P_0$	4.00±0.20
Sprocket Hole Dia.		$D_0$	1.55±0.20
Sprocket Hole Location		E	1.75±0.20
Pocket Location		F	5.50±0.20
		$P_2$	2.00±0.20
Pocket Pitch		P	8.00±0.20
Pocket Dimension		$A_0$	4.40±0.20
		$B_0$	7.30±0.20
		$K_0$	2.30±0.20
Pocket Hole Dia.		$D_1$	1.55±0.20
Cover Tape Width		$W_1$	9.20
Cover Tape Thickness		d	0.065±0.02
Max. Component Rotation or Tilt			20° max
Devices Per Reel	R1		500
	R2		2500
Reel Diameter	R1		178 mm (7")
	R2		330 mm (13")

HMA121A

HMA121B

HMA121C

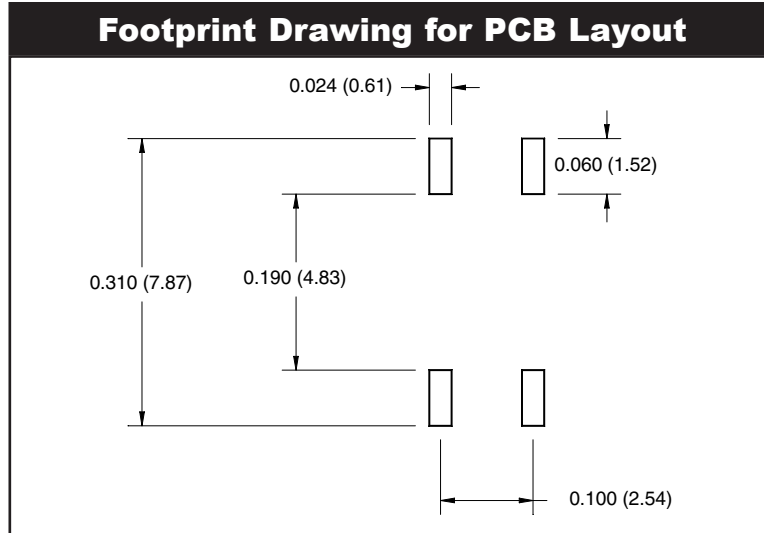

**Recommended Infrared Reflow Soldering Profile**

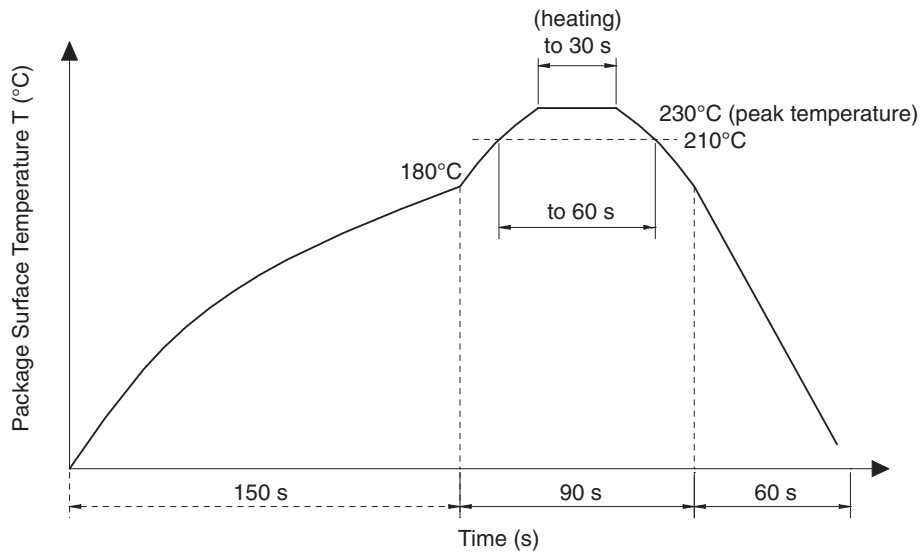

- Peak reflow temperature: 230°C (package surface temperature) for 30 seconds
- Time of temperature higher than 210°C: 60 seconds or less
- One time soldering reflow is recommended

---

**HMA121A**

**HMA121B**

**HMA121C**

---

## **DISCLAIMER**

FAIRCHILD SEMICONDUCTOR RESERVES THE RIGHT TO MAKE CHANGES WITHOUT FURTHER NOTICE TO ANY PRODUCTS HEREIN TO IMPROVE RELIABILITY, FUNCTION OR DESIGN. FAIRCHILD DOES NOT ASSUME ANY LIABILITY ARISING OUT OF THE APPLICATION OR USE OF ANY PRODUCT OR CIRCUIT DESCRIBED HEREIN; NEITHER DOES IT CONVEY ANY LICENSE UNDER ITS PATENT RIGHTS, NOR THE RIGHTS OF OTHERS.

## **LIFE SUPPORT POLICY**

FAIRCHILD'S PRODUCTS ARE NOT AUTHORIZED FOR USE AS CRITICAL COMPONENTS IN LIFE SUPPORT DEVICES OR SYSTEMS WITHOUT THE EXPRESS WRITTEN APPROVAL OF THE PRESIDENT OF FAIRCHILD SEMICONDUCTOR CORPORATION. As used herein:

1. Life support devices or systems are devices or systems which, (a) are intended for surgical implant into the body, or (b) support or sustain life, and (c) whose failure to perform when properly used in accordance with instructions for use provided in labeling, can be reasonably expected to result in a significant injury of the user.
2. A critical component in any component of a life support device or system whose failure to perform can be reasonably expected to cause the failure of the life support device or system, or to affect its safety or effectiveness.



LittleDiode supplies new, hard to find or obsolete electronic components and semiconductors all over the world.

With over two million different components listed you are sure to find the part you need.

Feel free to visit us today at our online store:

**[LittleDiode.com](http://LittleDiode.com)**

Looking forward to providing you with the best possible service.