

---

# HN29W25611 Series

256M AND type Flash Memory  
More than 16,057-sector (271,299,072-bit)

# HITACHI

ADE-203-995B (Z)  
Rev. 1.0  
Dec. 10, 1999

---

## Description

The Hitachi HN29W25611 Series is a CMOS Flash Memory with AND type multi-level memory cells. It has fully automatic programming and erase capabilities with a single 3.3 V power supply. The functions are controlled by simple external commands. To fit the I/O card applications, the unit of programming and erase is as small as (2048 + 64) bytes. Initial available sectors of HN29W25611 are more than 16,057 (98% of all sector address) and less than 16,384 sectors.

## Features

- On-board single power supply ( $V_{CC}$ ):  $V_{CC} = 3.3 \text{ V} \pm 0.3 \text{ V}$
- Organization
  - AND Flash Memory: (2048 + 64) bytes  $\times$  (More than 16,057 sectors)
  - Data register: (2048 + 64) bytes
- Multi-level memory cell
  - 2 bit/per memory cell
- Automatic programming
  - Sector program time: 3.0 ms (typ)
  - System bus free
  - Address, data latch function
  - Internal automatic program verify function
  - Status data polling function
- Automatic erase
  - Single sector erase time: 1.5 ms (typ)
  - System bus free
  - Internal automatic erase verify function
  - Status data polling function

---

## HN29W25611 Series

---

- Erase mode
  - Single sector erase ((2048 + 64) byte unit)
- Fast serial read access time:
  - First access time: 50  $\mu$ s (max)
  - Serial access time: 50 ns (max)
- Low power dissipation:
  - $I_{CC2}$  = 50 mA (max) (Read)
  - $I_{SB2}$  = 50  $\mu$ A (max) (Standby)
  - $I_{CC3}/I_{CC4}$  = 40 mA (max) (Erase/Program)
  - $I_{SB3}$  = 5  $\mu$ A (max) (Deep standby)
- The following architecture is required for data reliability.
  - Error correction: more than 3-bit error correction per each sector read
  - Spare sectors: 1.8% (290 sectors) within usable sectors

### Ordering Information

Type No.	Available sector	Package
HN29W25611T-50	More than 16,057 sectors	12.0 $\times$ 18.40 mm <sup>2</sup> 0.5 mm pitch 48-pin plastic TSOP I (TFP-48D)

---

Pin Arrangement

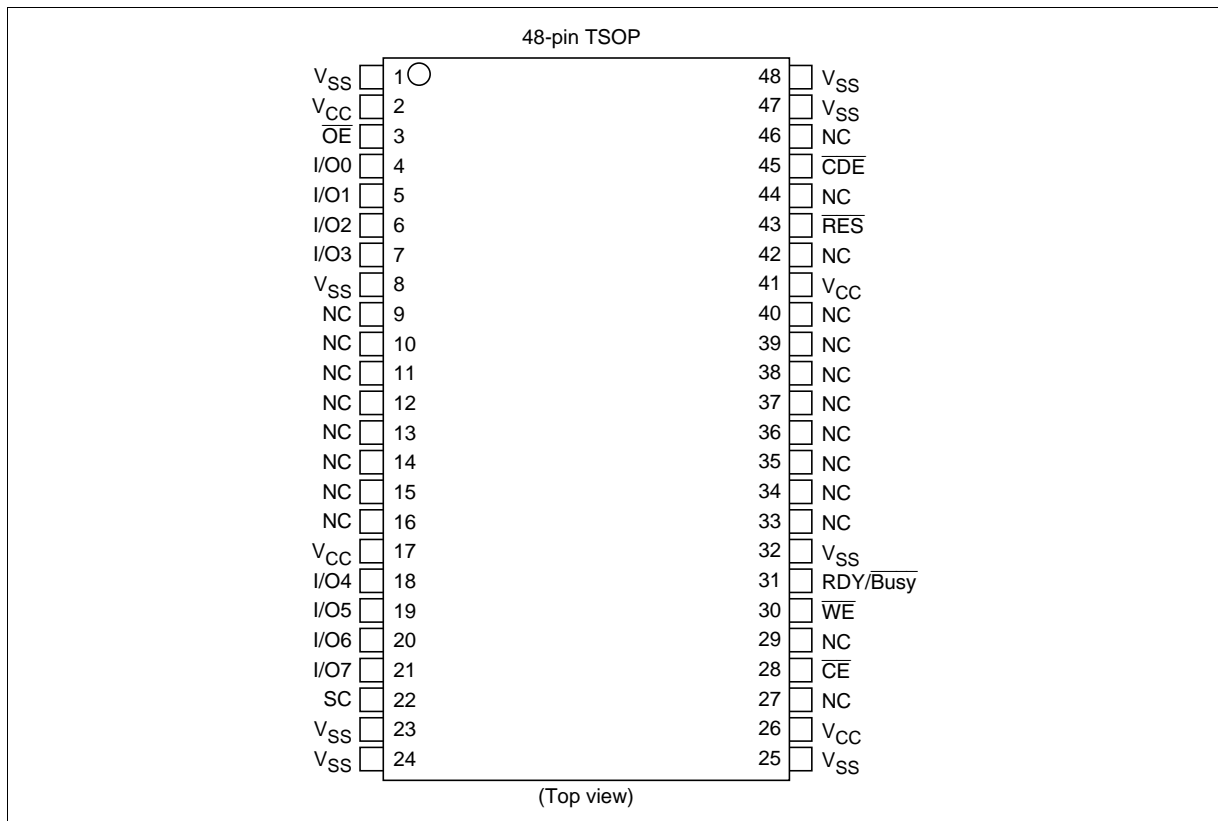

Pin Description

Pin name	Function
I/O0 to I/O7	Input/output
$\overline{CE}$	Chip enable
$\overline{OE}$	Output enable
$\overline{WE}$	Write enable
$\overline{CDE}$	Command data enable
V <sub>CC</sub> <sup>*1</sup>	Power supply
V <sub>SS</sub> <sup>*1</sup>	Ground
$\overline{RDY/Busy}$	Ready/Busy
$\overline{RES}$	Reset
SC	Serial clock
NC	No connection

Note: 1. All V<sub>CC</sub> and V<sub>SS</sub> pins should be connected to a common power supply and a ground, respectively.

## Block Diagram

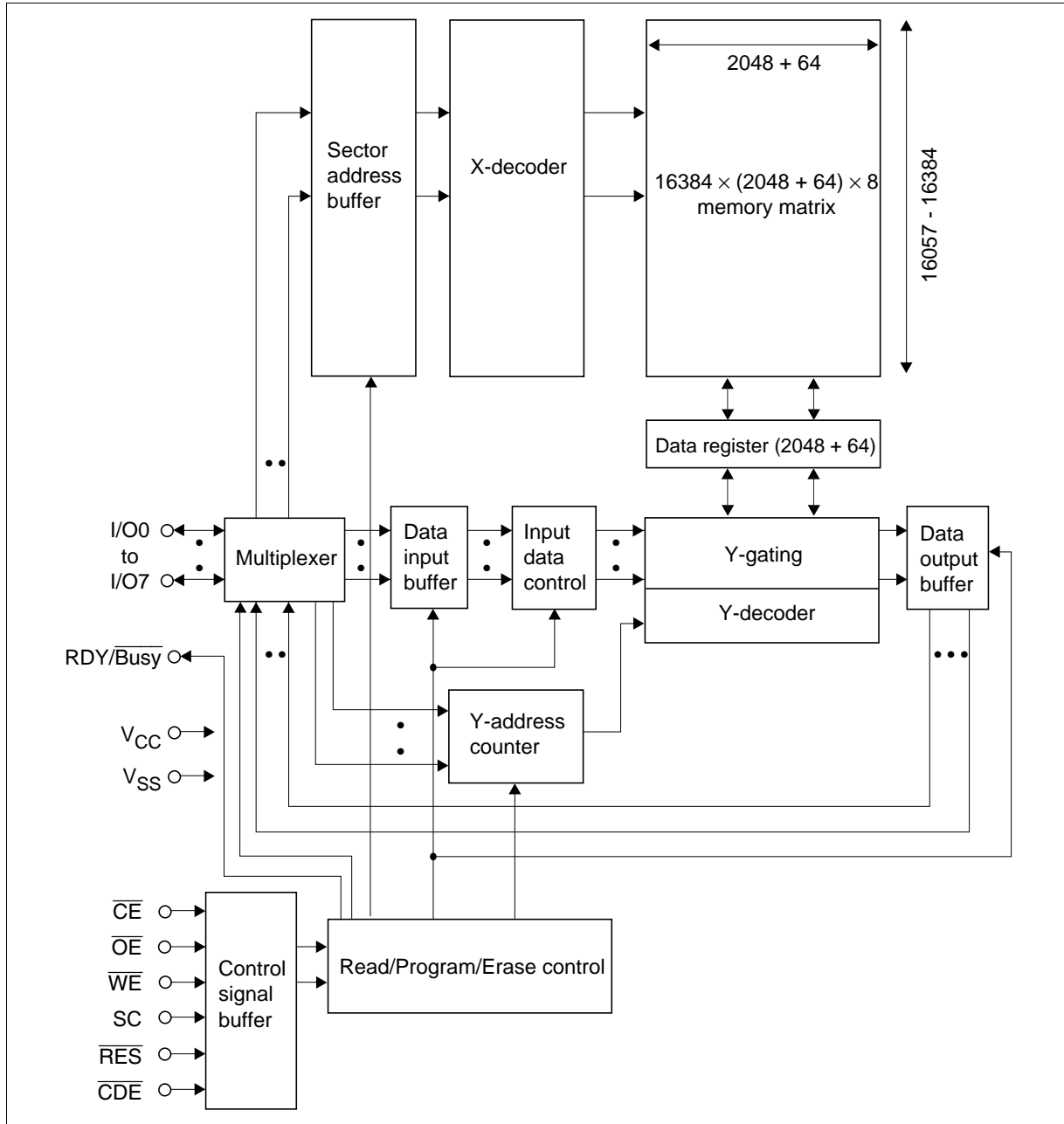

Memory Map and Address

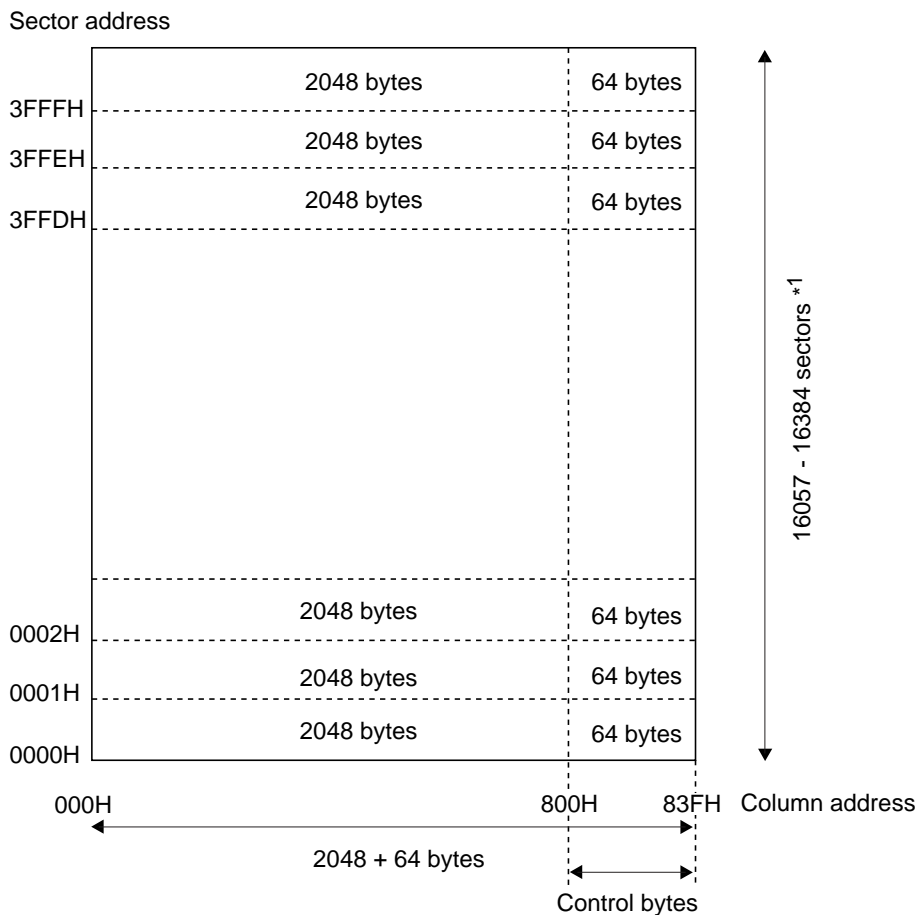

Address	Cycles	I/O0	I/O1	I/O2	I/O3	I/O4	I/O5	I/O6	I/O7
Sector address	SA (1): First cycle	A0	A1	A2	A3	A4	A5	A6	A7
	SA (2): Second cycle	A8	A9	A10	A11	A12	A13	×*2	×
Column address	CA (1): First cycle	A0	A1	A2	A3	A4	A5	A6	A7
	CA (2): Second cycle	A8	A9	A10	A11	×	×	×	×

- Notes: 1. Some failed sectors may exist in the device. The failed sectors can be recognized by reading the sector valid data written in a part of the column address 800 to 83F (The specific address is TBD.). The sector valid data must be read and kept outside of the sector before the sector erase. When the sector is programmed, the sector valid data should be written back to the sector.
2. An × means "Don't care". The pin level can be set to either  $V_{IL}$  or  $V_{IH}$ , referred to DC characteristics.

## Pin Function

**$\overline{CE}$ :**  $\overline{CE}$  is used to select the device. The status returns to the standby at the rising edge of  $\overline{CE}$  in the reading operation. However, the status does not return to the standby at the rising edge of  $\overline{CE}$  in the busy state in programming and erase operation.

**$\overline{OE}$ :** Memory data and status register data can be read, when  $\overline{OE}$  is  $V_{IL}$ .

**$\overline{WE}$ :** Commands and address are latched at the rising edge of  $\overline{WE}$ .

**SC:** Programming and reading data is latched at the rising edge of SC.

**$\overline{RES}$ :**  $\overline{RES}$  pin must be kept at the  $V_{ILR}$  ( $V_{SS} \pm 0.2$  V) level when  $V_{CC}$  is turned on and off. In this way, data in the memory is protected against unintentional erase and programming.  $\overline{RES}$  must be kept at the  $V_{IHR}$  ( $V_{CC} \pm 0.2$  V) level during any operations such as programming, erase and read.

**$\overline{CDE}$ :** Commands and data are latched when  $\overline{CDE}$  is  $V_{IL}$  and address is latched when  $\overline{CDE}$  is  $V_{IH}$ .

**$RDY/\overline{Busy}$ :** The  $RDY/\overline{Busy}$  indicates the program/erase status of the flash memory. The  $RDY/\overline{Busy}$  signal is initially at a high impedance state. It turns to a  $V_{OL}$  level after the (40H) command in programming operation or the (B0H) command in erase operation. After the erase or programming operation finishes, the  $RDY/\overline{Busy}$  signal turns back to the high impedance state.

**I/O0 to I/O7:** The I/O pins are used to input data, address and command, and are used to output memory data and status register data.

## Mode Selection

Mode	$\overline{CE}$	$\overline{OE}$	$\overline{WE}$	SC	$\overline{RES}$	$\overline{CDE}$	$RDY/\overline{Busy}^{*3}$	I/O0 to I/O7
Deep standby	$\times^{*4}$	$\times$	$\times$	$\times$	$V_{ILR}$	$\times$	$V_{OH}$	High-Z
Standby	$V_{IH}$	$\times$	$\times$	$\times$	$V_{IHR}$	$\times$	$V_{OH}$	High-Z
Output disable	$V_{IL}$	$V_{IH}$	$V_{IH}$	$\times$	$V_{IHR}$	$\times$	$V_{OH}$	High-Z
Status register read <sup>*1</sup>	$V_{IL}$	$V_{IL}$	$V_{IH}$	$\times$	$V_{IHR}$	$\times$	$V_{OH}$	Status register outputs
Command write <sup>*2</sup>	$V_{IL}$	$V_{IH}$	$V_{IL}$	$V_{IL}$	$V_{IHR}$	$V_{IL}$	$V_{OH}$	Din

Notes: 1. Default mode after the power on is the status register read mode (refer to status transition). From I/O0 to I/O7 pins output the status, when  $\overline{CE} = V_{IL}$  and  $\overline{OE} = V_{IL}$  (conventional read operation condition).

2. Refer to the command definition. Data can be read, programmed and erased after commands are written in this mode.

3. The  $RDY/\overline{Busy}$  bus should be pulled up to  $V_{CC}$  to maintain the  $V_{OH}$  level while the  $RDY/\overline{Busy}$  pin outputs a high impedance.

4. An  $\times$  means "Don't care". The pin level can be set to either  $V_{IL}$  or  $V_{IH}$  referred to DC characteristics.

Command Definition\*1,2

Command		Bus cycles	First bus cycle		Second bus cycle		
			Operation mode*3	Data in	Operation mode	Data in	Data out
Read	Serial read (1)	(Without CA)	3	Write	00H	Write	SA (1)**4
		(With CA)	3 + 2h*6	Write	00H	Write	SA (1)**4
	Serial read (2)	3	Write	F0H	Write	SA (1)**4	
	Read identifier codes	1	Write	90H	Read	ID*8,9	
	Data recovery read	1	Write	01H	Read	Recovery data	
Auto erase	Single sector	4	Write	20H	Write	SA (1)**4	
Auto program	Program (1)	(Without CA*7)	4	Write	10H	Write	SA (1)**4
		(With CA*7)	4 + 2h*6	Write	10H	Write	SA (1)**4
	Program (2)*10	4	Write	1FH	Write	SA (1)**4	
	Program (3) (Control bytes)*7	4	Write	0FH	Write	SA (1)**4	
	Program (4)	(Without CA*7)	4	Write	11H	Write	SA (1)**4
(With CA*7)		4 + 2h*6	Write	11H	Write	SA (1)**4	
Reset		1	Write	FFH			
Clear status register		1	Write	50H			
Data recovery write		4	Write	12H	Write	SA (1)**4	

# HN29W25611 Series

Command		Bus cycles	Third bus cycle		Fourth bus cycle		
			Operation mode	Data in	Operation mode	Data in	
Read	Serial read (1)	(Without CA)	3	Write	SA (2) <sup>*4</sup>		
		(With CA)	3 + 2h <sup>*6</sup>	Write	SA (2) <sup>*4</sup>	Write	CA (1) <sup>*5</sup>
	Serial read (2)	3	Write	SA (2) <sup>*4</sup>			
	Read identifier codes	1					
	Data recovery read	1					
Auto erase	Single sector	4	Write	SA (2) <sup>*4</sup>	Write	B0H <sup>*11</sup>	
Auto program	Program (1)	(Without CA <sup>*7</sup> )	4	Write	SA (2) <sup>*4</sup>	Write	40H <sup>*11, 12</sup>
		(With CA <sup>*7</sup> )	4 + 2h <sup>*6</sup>	Write	SA (2) <sup>*4</sup>	Write	CA (1)
	Program (2) <sup>*10</sup>	4	Write	SA (2) <sup>*4</sup>	Write	40H <sup>*11, 12</sup>	
	Program (3) (Control bytes) <sup>*7</sup>	4	Write	SA (2) <sup>*4</sup>	Write	40H <sup>*11, 12</sup>	
	Program (4)	(Without CA <sup>*7</sup> )	4	Write	SA (2) <sup>*4</sup>	Write	40H <sup>*11, 12</sup>
(With CA <sup>*7</sup> )		4 + 2h <sup>*6</sup>	Write	SA (2) <sup>*4</sup>	Write	CA (1)	
Reset		1					
Clear status register		1					
Data recovery write		4	Write	SA (2) <sup>*4</sup>	Write	40H <sup>*11, 12</sup>	

Command		Bus cycles	Fifth bus cycle		Sixth bus cycle	
			Operation mode	Data in	Operation mode	Data in
Read	Serial read (1) (Without CA)	3				
	(With CA)	3 + 2h* <sup>6</sup>	Write	CA (2)* <sup>5</sup>		
	Serial read (2)	3				
	Read identifier codes	1				
	Data recovery read	1				
Auto erase	Single sector	4				
Auto program	Program (1) (Without CA* <sup>7</sup> )	4				
	(With CA* <sup>7</sup> )	4 + 2h* <sup>6</sup>	Write	CA (2)* <sup>5</sup>	Write	40H* <sup>11, 12</sup>
	Program (2)* <sup>10</sup>	4				
	Program (3) (Control bytes)* <sup>7</sup>	4				
	Program (4) (Without CA* <sup>7</sup> )	4				
(With CA* <sup>7</sup> )	4 + 2h* <sup>6</sup>	Write	CA (2)	Write	40H* <sup>11, 12</sup>	
Reset		1				
Clear status register		1				
Data recovery write		4				

- Notes:
1. Commands and sector address are latched at rising edge of  $\overline{WE}$  pulses. Program data is latched at rising edge of SC pulses.
  2. The chip is in the read status register mode when  $\overline{RES}$  is set to  $V_{IHR}$  first time after the power up.
  3. Refer to the command read and write mode in mode selection.
  4. SA (1) = Sector address (A0 to A7), SA (2) = Sector address (A8 to A13).
  5. CA (1) = Column address (A0 to A7), CA (2) = Column address (A8 to A11).  
( $0 \leq A11$  to  $A0 \leq 83FH$ )
  6. The variable h is the input number of times of set of CA (1) and CA (2) ( $1 \leq h \leq 2048 + 64$ ).  
Set of CA (1) and CA (2) can be input not only one time but free times.
  7. By using program (1) and (3), data can additionally be programmed for each sector before erase.
  8. ID = Identifier code; Manufacturer code (07H), Device code (99H).
  9. The manufacturer identifier code is output when  $\overline{CDE}$  is low and the device identifier code is output when  $\overline{CDE}$  is high.
  10. Before program (2) operations, data in the programmed sector must be erased.
  11. No commands can be written during auto program and erase (when the RDY/ $\overline{Busy}$  pin outputs a  $V_{OL}$ ).
  12. The fourth or sixth cycle of the auto program comes after the program data input is complete.

## Mode Description

### Read

**Serial Read (1):** Memory data D0 to D2111 in the sector of address SA is sequentially read. Output data is not valid after the number of the SC pulse exceeds 2112. When CA is input, memory data D (m) to D (m + j) in the sector of address SA is sequentially read. Then output data is not valid after the number of the SC pulse exceeds (2112 to m). The mode turns back to the standby mode at any time when  $\overline{CE}$  is  $V_{IH}$ .

**Serial Read (2):** Memory data D2048 to D2111 in the sector of address SA is sequentially read. Output data is not valid after the number of the SC pulse exceeds 64. The mode turns back to the standby mode at any time when  $\overline{CE}$  is  $V_{IH}$ .

### Automatic Erase

**Single Sector Erase:** Memory data D0 to D2111 in the sector of address SA is erased automatically by internal control circuits. After the sector erase starts, the erasure completion can be checked through the  $\overline{RDY/Busy}$  signal and status data polling. All the bits in the sector are "1" after the erase. The sector valid data stored in a part of memory data D2048 to D2111 must be read and kept outside of the sector before the sector erase.

### Automatic Program

**Program (1):** Program data PD0 to PD2111 is programmed into the sector of address SA automatically by internal control circuits. When CA is input, program data PD (m) to PD (m + j) is programmed from CA into the sector of address SA automatically by internal control circuits. By using program (1), data can additionally be programmed for each sector before the following erase. When the column is programmed, the data of the column must be [FF]. After the programming starts, the program completion can be checked through the  $\overline{RDY/Busy}$  signal and status data polling. Programmed bits in the sector turn from "1" to "0" when they are programmed. The sector valid data should be included in the program data PD2048 to PD2111.

**Program (2):** Program data PD0 to PD2111 is programmed into the sector of address SA automatically by internal control circuits. After the programming starts, the program completion can be checked through the  $\overline{RDY/Busy}$  signal and status data polling. Programmed bits in the sector turn from "1" to "0" when they are programmed. The sector must be erased before programming. The sector valid data should be included in the program data PD2048 to PD2111.

**Program (3):** Program data PD2048 to PD2111 is programmed into the sector of address SA automatically by internal control circuits. By using program (3), data can additionally be programmed for each sector before the following erase. When the column is programmed, the data of the column must be [FF]. After the programming starts, the program completion can be checked through the  $\overline{RDY/Busy}$  signal and status data polling. Programmed bits in the sector turn from "1" to "0" when they are programmed.

**Program (4):** Program data PD0 to PD2111 is programmed into the sector of address SA automatically by internal control circuits. When CA is input, program data PD (m) to PD (m + j) is programmed from CA into the sector of address SA automatically by internal control circuits. By using program (4), data can be rewritten for each sector before the following erase. So the column data before programming operation are either "1" or "0". In this mode, E/W number of times must be counted whenever program (4) execute. After the programming starts, the program completion can be checked through the RDY/ $\overline{\text{Busy}}$  signal and status data polling. The sector valid data should be included in the program data PD2048 to PD2111.

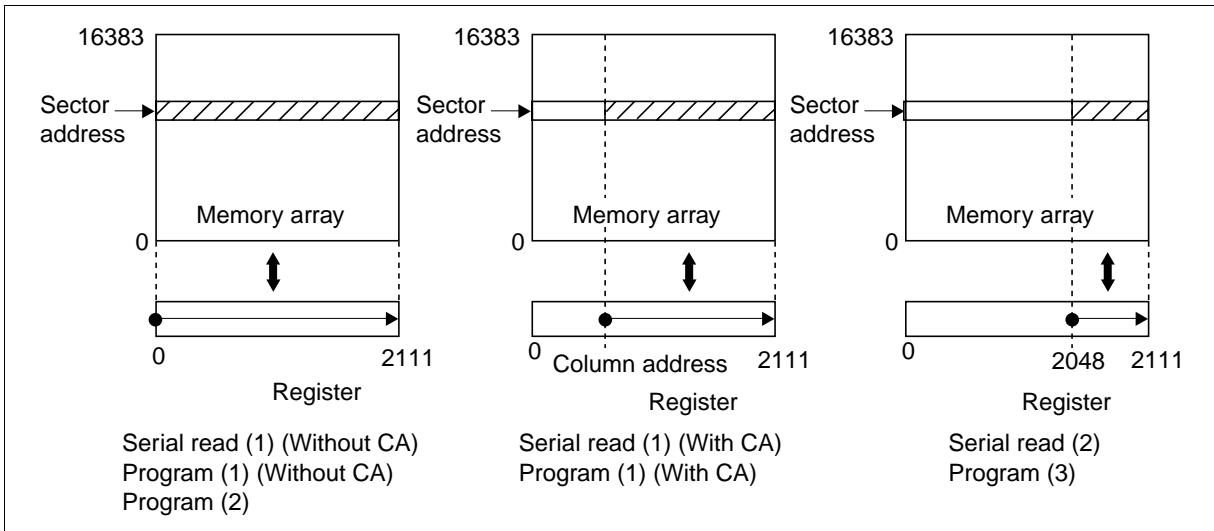

**Status Register Read**

The status returns to the status register read mode from standby mode, when  $\overline{\text{CE}}$  and  $\overline{\text{OE}}$  is  $V_{\text{IL}}$ . In the status register read mode, I/O pins output the same operation status as in the status data polling defined in the function description.

**Identifier Read**

The manufacturer and device identifier code can be read in the identifier read mode. The manufacturer and device identifier code is selected with  $\overline{\text{CDE}} V_{\text{IL}}$  and  $V_{\text{IH}}$ , respectively.

### Data Recovery Read

When the programming was an error, the program data can be read by using data recovery read. When an additional programming was an error, the data compounded of the program data and the origin data in the sector address SA can be read. Output data are not valid after the number of SA pulse exceeds 2112. The mode turns back to the standby mode at any time when  $\overline{CE}$  is  $V_{IH}$ . The read data are invalid when addresses are latched at a rising edge of  $\overline{WE}$  pulse after the data recovery read command is written.

### Data Recovery Write

When the programming into a sector of address SA was an error, the program data can be rewritten automatically by internal control circuit into the other selected sector of address SA'. In this case, top address [SA13] of sector of address SA' must be the same as SA. Since the data recovery write mode is internally Program (4) mode, rewritten sector of address SA' needs no sector erase before rewrite. After the data recovery write mode starts, the program completion can be checked through the RDY/ $\overline{Busy}$  signal and the status data polling.

## Command/Address/Data Input Sequence

### Serial Read (1) (With CA before SC)

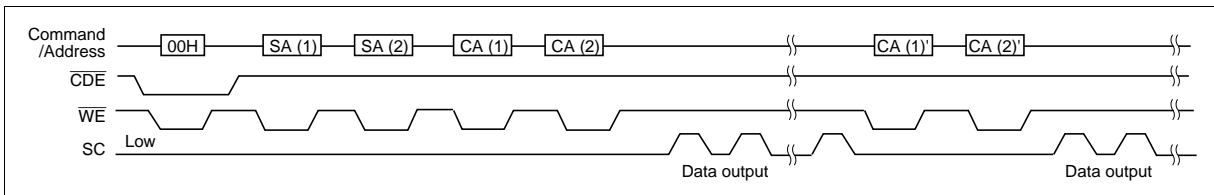

### Serial Read (1) (With CA after SC)

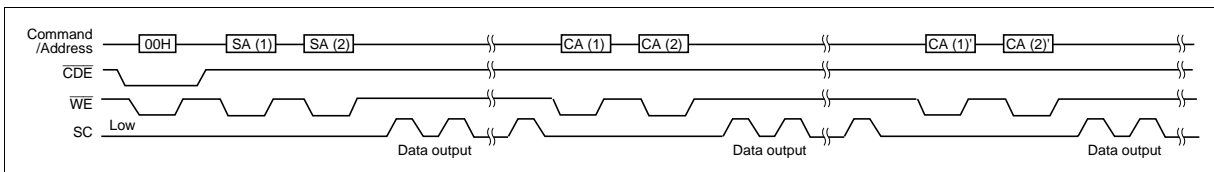

### Serial Read (1) (Without CA), (2)

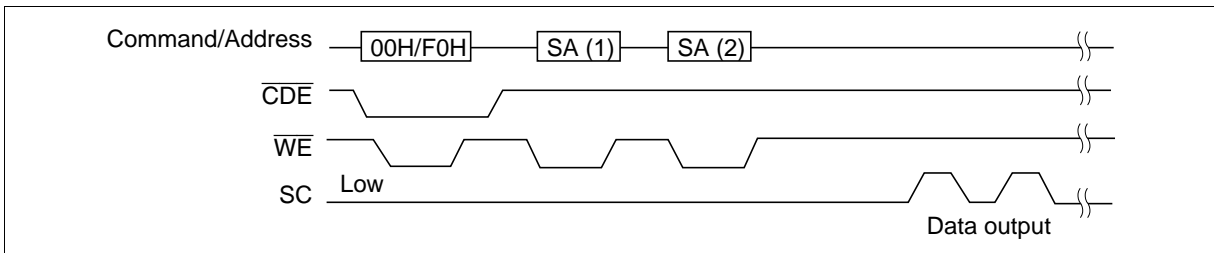

### Single Sector Erase

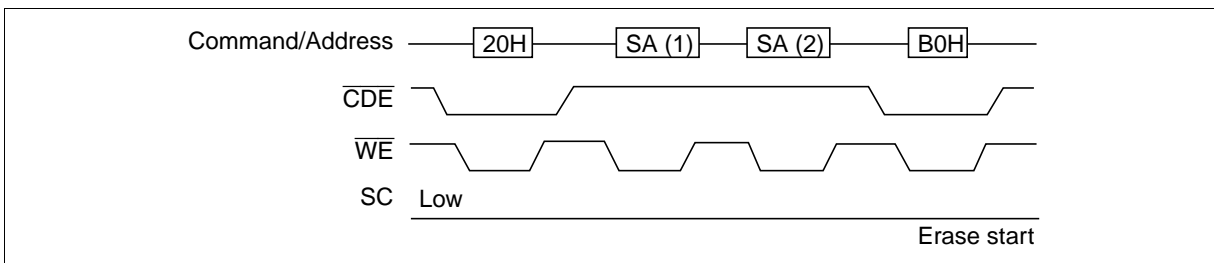

## Program (1), (4) (With CA before SC)

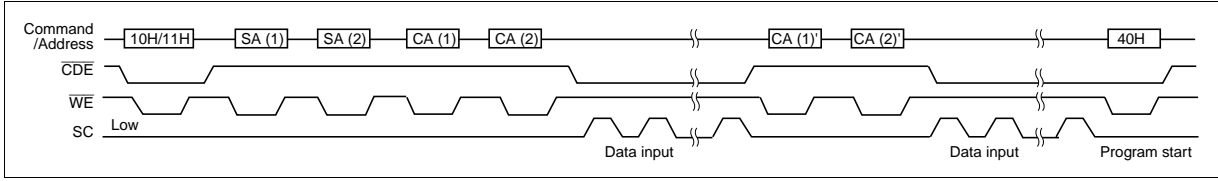

## Program (1), (4) (With CA after SC)

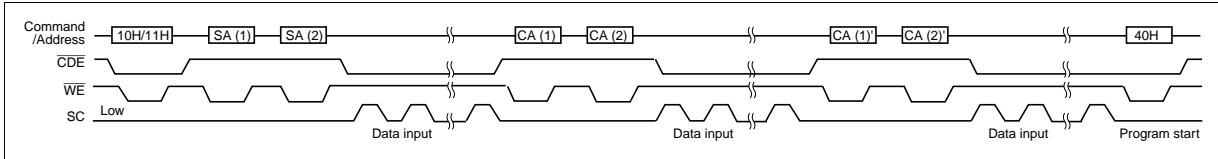

## Program (1), (4) (Without CA)

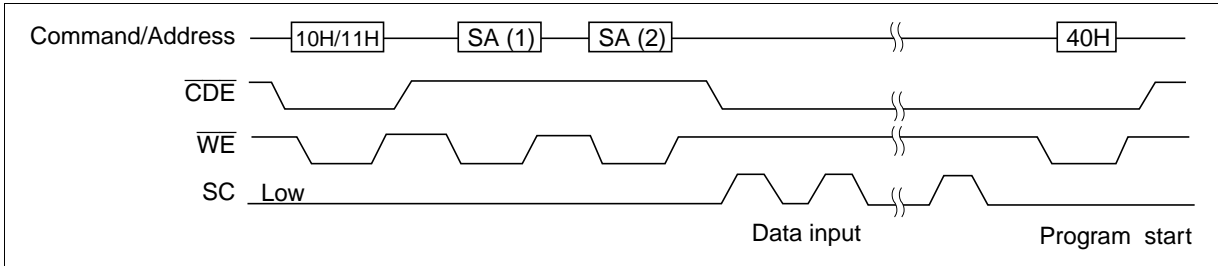

## Program (2)

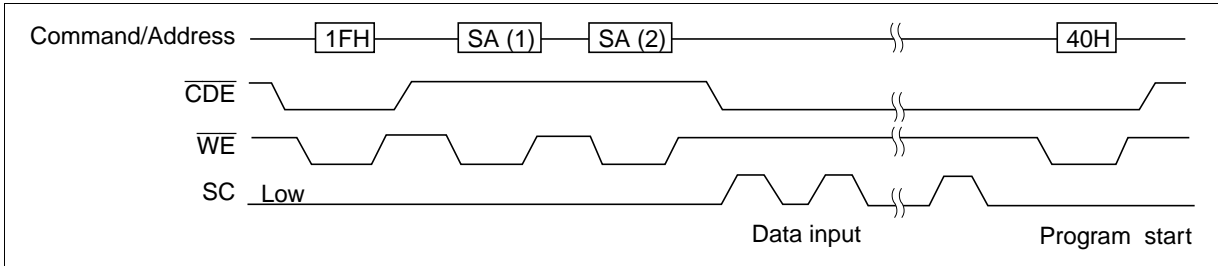

**Program (3)**

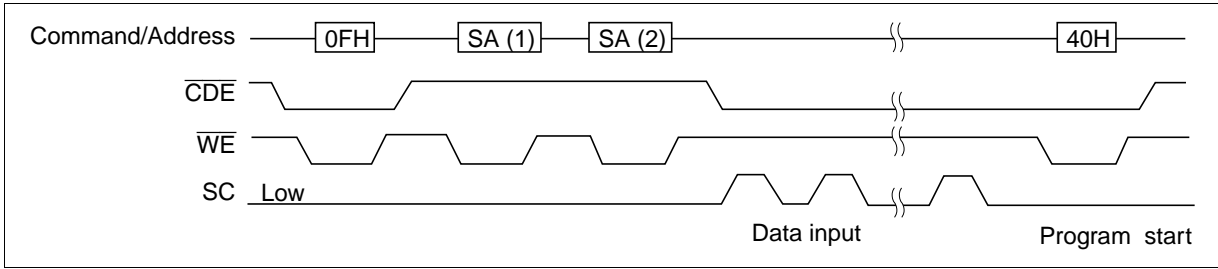

**ID Read Mode**

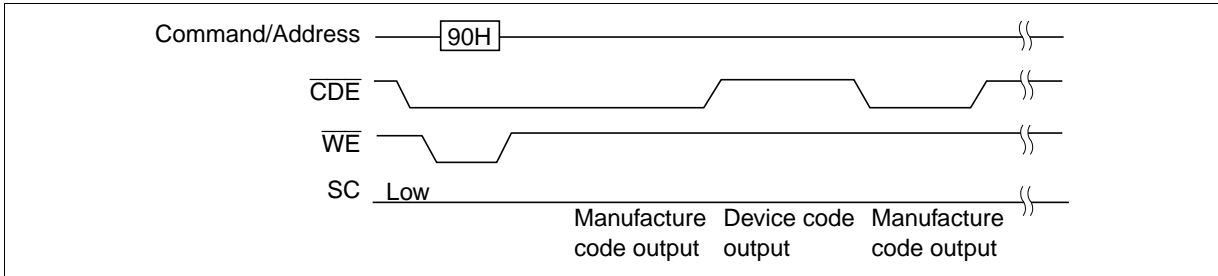

**Data Recovery Read Mode**

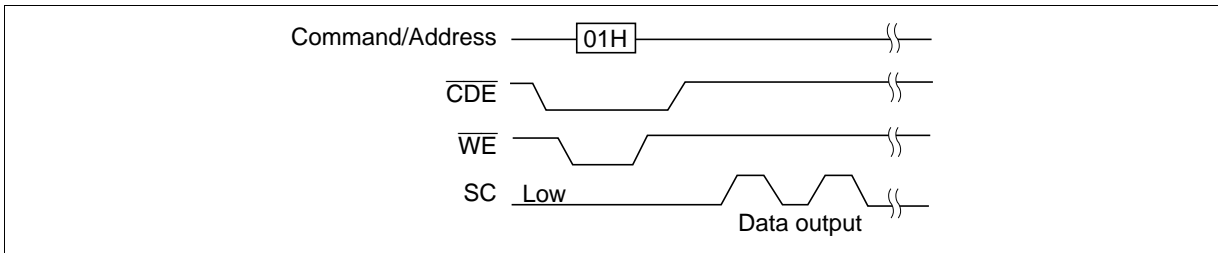

**Data Recovery Write Mode**

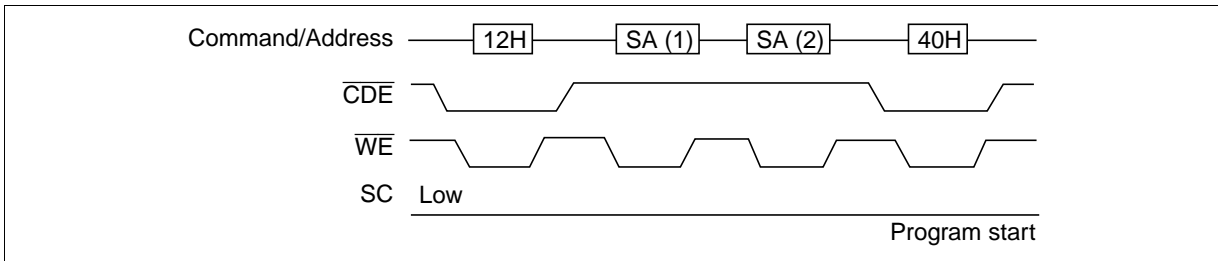



### Absolute Maximum Ratings

Parameter	Symbol	Value	Unit	Notes
V <sub>CC</sub> voltage	V <sub>CC</sub>	-0.6 to +7	V	1
V <sub>SS</sub> voltage	V <sub>SS</sub>	0	V	
All input and output voltages	V <sub>in</sub> , V <sub>out</sub>	-0.6 to +7	V	1, 2
Operating temperature range	T <sub>opr</sub>	0 to +70	°C	
Storage temperature range	T <sub>stg</sub>	-65 to +125	°C	3
Storage temperature under bias	T <sub>bias</sub>	-10 to +80	°C	

Notes: 1. Relative to V<sub>SS</sub>.

2. V<sub>in</sub>, V<sub>out</sub> = -2.0 V for pulse width ≤ 20 ns.

3. Device storage temperature range before programming.

### Capacitance (T<sub>a</sub> = 25°C, f = 1 MHz)

Parameter	Symbol	Min	Typ	Max	Unit	Test conditions
Input capacitance	C <sub>in</sub>	—	—	6	pF	V <sub>in</sub> = 0 V
Output capacitance	C <sub>out</sub>	—	—	12	pF	V <sub>out</sub> = 0 V

# HN29W25611 Series

## DC Characteristics ( $V_{CC} = 3.3 \text{ V} \pm 0.3 \text{ V}$ , $T_a = 0 \text{ to } +70^\circ\text{C}$ )

Parameter	Symbol	Min	Typ	Max	Unit	Test conditions
Input leakage current	$I_{LI}$	—	—	2	$\mu\text{A}$	$V_{in} = V_{SS} \text{ to } V_{CC}$
Output leakage current	$I_{LO}$	—	—	2	$\mu\text{A}$	$V_{out} = V_{SS} \text{ to } V_{CC}$
Standby $V_{CC}$ current	$I_{SB1}$	—	0.3	1	$\text{mA}$	$\overline{CE} = V_{IH}$
	$I_{SB2}$	—	30	50	$\mu\text{A}$	$\overline{CE} = V_{CC} \pm 0.2 \text{ V}$ , $\overline{RES} = V_{CC} \pm 0.2 \text{ V}$
Deep standby $V_{CC}$ current	$I_{SB3}$	—	1	5	$\mu\text{A}$	$\overline{RES} = V_{SS} \pm 0.2 \text{ V}$
Operating $V_{CC}$ current	$I_{CC1}$	—	20	25	$\text{mA}$	$I_{out} = 0 \text{ mA}$ , $f = 0.2 \text{ MHz}$
	$I_{CC2}$	—	30	50	$\text{mA}$	$I_{out} = 0 \text{ mA}$ , $f = 20 \text{ MHz}$
Operating $V_{CC}$ current (Program)	$I_{CC3}$	—	20	40	$\text{mA}$	In programming
Operating $V_{CC}$ current (Erase)	$I_{CC4}$	—	20	40	$\text{mA}$	In erase
Input voltage	$V_{IL}$	$-0.3^{*1,2}$	—	0.8	$\text{V}$	
	$V_{IH}$	2.0	—	$V_{CC} + 0.3^{*3}$	$\text{V}$	
Input voltage ( $\overline{RES}$ pin)	$V_{ILR}$	-0.2	—	0.2	$\text{V}$	
	$V_{IHR}$	$V_{CC} - 0.2$	—	$V_{CC} + 0.2$	$\text{V}$	
Output voltage	$V_{OL}$	—	—	0.4	$\text{V}$	$I_{OL} = 2 \text{ mA}$
	$V_{OH}$	2.4	—	—	$\text{V}$	$I_{OH} = -2 \text{ mA}$

- Notes: 1.  $V_{IL}$  min = -1.0 V for pulse width  $\leq 50 \text{ ns}$  in the read operation.  $V_{IL}$  min = -2.0 V for pulse width  $\leq 20 \text{ ns}$  in the read operation.
2.  $V_{IL}$  min = -0.6 V for pulse width  $\leq 20 \text{ ns}$  in the erase/data programming operation.
3.  $V_{IH}$  max =  $V_{CC} + 1.5 \text{ V}$  for pulse width  $\leq 20 \text{ ns}$ . If  $V_{IH}$  is over the specified maximum value, the operations are not guaranteed.

## AC Characteristics ( $V_{CC} = 3.3 \text{ V} \pm 0.3 \text{ V}$ , $T_a = 0 \text{ to } +70^\circ\text{C}$ )

### Test Conditions

- Input pulse levels: 0.4 V/2.4 V
- Input pulse levels for  $\overline{RES}$ : 0.2 V/ $V_{CC} - 0.2 \text{ V}$
- Input rise and fall time:  $\leq 5 \text{ ns}$
- Output load: 1 TTL gate + 100 pF (Including scope and jig.)
- Reference levels for measuring timing: 0.8 V, 1.8 V

## Power on and off, Serial Read Mode

Parameter	Symbol	Min	Typ	Max	Unit	Test conditions	Notes
Write cycle time	$t_{CWC}$	120	—	—	ns		
Serial clock cycle time	$t_{SCC}$	50	—	—	ns		
$\overline{CE}$ setup time	$t_{CES}$	0	—	—	ns		
$\overline{CE}$ hold time	$t_{CEH}$	0	—	—	ns		
Write pulse time	$t_{WP}$	60	—	—	ns	$\overline{CE} = V_{IL}, \overline{OE} = V_{IH}$	
Write pulse high time	$t_{WPH}$	40	—	—	ns		
Address setup time	$t_{AS}$	50	—	—	ns		
Address hold time	$t_{AH}$	10	—	—	ns		
Data setup time	$t_{DS}$	50	—	—	ns		
Data hold time	$t_{DH}$	10	—	—	ns		
SC to output delay	$t_{SAC}$	—	—	50	ns	$\overline{CE} = \overline{OE} = V_{IL}, \overline{WE} = V_{IH}$	
$\overline{OE}$ setup time for SC	$t_{OES}$	0	—	—	ns		
$\overline{OE}$ low to output low-Z	$t_{OEL}$	0	—	40	ns		
$\overline{OE}$ setup time before read	$t_{OER}$	250	—	—	ns		
$\overline{OE}$ setup time before command write	$t_{OEWS}$	0	—	—	ns		
SC to output hold	$t_{SH}$	15	—	—	ns	$\overline{CE} = \overline{OE} = V_{IL}, \overline{WE} = V_{IH}$	
$\overline{OE}$ high to output float	$t_{DF}$	—	—	40	ns	$\overline{CE} = V_{IL}, \overline{WE} = V_{IH}$	1
$\overline{WE}$ to SC delay time	$t_{WSD}$	50	—	—	$\mu$ s		2
$\overline{RES}$ to $\overline{CE}$ setup time	$t_{RP}$	1	—	—	ms		
SC to $\overline{OE}$ hold time	$t_{SOH}$	50	—	—	ns		
SC pulse width	$t_{SP}$	20	—	—	ns		
SC pulse low time	$t_{SPL}$	20	—	—	ns		
SC setup time for $\overline{CE}$	$t_{SCS}$	0	—	—	ns		
$\overline{CDE}$ setup time for $\overline{WE}$	$t_{CDS}$	0	—	—	ns		
$\overline{CDE}$ hold time for $\overline{WE}$	$t_{CDH}$	20	—	—	ns		
$V_{CC}$ setup time for $\overline{RES}$	$t_{VRS}$	1	—	—	$\mu$ s	$\overline{CE} = V_{IH}$	
$\overline{RES}$ to $V_{CC}$ hold time	$t_{VRH}$	1	—	—	$\mu$ s	$\overline{CE} = V_{IH}$	
$\overline{CE}$ setup time for $\overline{RES}$	$t_{CESR}$	1	—	—	$\mu$ s		
RDY/ $\overline{Busy}$ undefined for $V_{CC}$ off	$t_{DFP}$	0	—	—	ns		
$\overline{RES}$ high to device ready	$t_{BSY}$	—	—	1	ms		
$\overline{CE}$ pulse high time	$t_{CPH}$	200	—	—	ns		
$\overline{CE}, \overline{WE}$ setup time for $\overline{RES}$	$t_{CWRS}$	0	—	—	ns		
$\overline{RES}$ to $\overline{CE}, \overline{WE}$ hold time	$t_{CWRH}$	0	—	—	ns		

## HN29W25611 Series

Parameter	Symbol	Min	Typ	Max	Unit	Test conditions	Notes
SC setup for $\overline{WE}$	$t_{SW}$	50	—	—	ns		
$\overline{CE}$ hold time for $\overline{OE}$	$t_{COH}$	0	—	—	ns		
SA (2) to CA (2) delay time	$t_{SCD}$	—	—	30	$\mu$ s		
RDY/ $\overline{Busy}$ setup for SC	$t_{RS}$	200	—	—	ns		
Time to device busy on read mode	$t_{DBR}$	—	—	1	$\mu$ s		
Busy time on reset mode	$t_{RBSY}$	—	45	—	$\mu$ s		

- Notes: 1.  $t_{DF}$  is a time after which the I/O pins become open.
2.  $t_{WSD}$  (min) is specified as a reference point only for SC, if  $t_{WSD}$  is greater than the specified  $t_{WSD}$  (min) limit, then access time is controlled exclusively by  $t_{SAC}$ .

**Program, Erase and Erase Verify**

Parameter	Symbol	Min	Typ	Max	Unit	Test conditions	Note
Write cycle time	$t_{CWC}$	120	—	—	ns		
Serial clock cycle time	$t_{SCC}$	50	—	—	ns		
$\overline{CE}$ setup time	$t_{CES}$	0	—	—	ns		
$\overline{CE}$ hold time	$t_{CEH}$	0	—	—	ns		
Write pulse time	$t_{WP}$	60	—	—	ns		
Write pulse high time	$t_{WPH}$	40	—	—	ns		
Address setup time	$t_{AS}$	50	—	—	ns		
Address hold time	$t_{AH}$	10	—	—	ns		
Data setup time	$t_{DS}$	50	—	—	ns		
Data hold time	$t_{DH}$	10	—	—	ns		
$\overline{OE}$ setup time before command write	$t_{OEWS}$	0	—	—	ns		
$\overline{OE}$ setup time before status polling	$t_{OEPS}$	40	—	—	ns		
$\overline{OE}$ setup time before read	$t_{OER}$	250	—	—	ns		
Time to device busy	$t_{DB}$	—	—	150	ns		
Time to device busy on read mode	$t_{DBR}$	—	—	1	$\mu$ s		
Auto erase time	$t_{ASE}$	—	1.5	5.0	ms		
Auto program time Program(1), (3)	$t_{ASP}$	—	3.0	20.0	ms		
Program(2)	$t_{ASP}$	—	2.5	20.0	ms		
Program(4), Data recovery write	$t_{ASP}$	—	3.5	30.0	ms		
$\overline{WE}$ to SC delay time	$t_{WSD}$	50	—	—	$\mu$ s		
$\overline{WE}$ to SC delay time on recovery read mode	$t_{WSDR}$	2	—	—	$\mu$ s		
$\overline{CE}$ pulse high time	$t_{CPH}$	200	—	—	ns		
SC pulse width	$t_{SP}$	20	—	—	ns		
SC pulse low time	$t_{SPL}$	20	—	—	ns		
Data setup time for SC	$t_{SDS}$	0	—	—	ns		
Data hold time for SC	$t_{SDH}$	30	—	—	ns	$\overline{CDE} = V_{IL}$	
SC setup for $\overline{WE}$	$t_{SW}$	50	—	—	ns		
SC setup for $\overline{CE}$	$t_{SCS}$	0	—	—	ns		
SC hold time for $\overline{WE}$	$t_{SCHW}$	20	—	—	ns		
$\overline{CE}$ to output delay	$t_{CE}$	—	—	120	ns		

# HN29W25611 Series

Parameter	Symbol	Min	Typ	Max	Unit	Test conditions	Note
$\overline{\text{OE}}$ to output delay	$t_{\text{OE}}$	—	—	60	ns		
$\overline{\text{OE}}$ high to output float	$t_{\text{DF}}$	—	—	40	ns		1
$\overline{\text{RES}}$ to $\overline{\text{WE}}$ setup time	$t_{\text{RP}}$	1	—	—	ms		
$\overline{\text{CDE}}$ setup time for $\overline{\text{WE}}$	$t_{\text{CDS}}$	0	—	—	ns		
$\overline{\text{CDE}}$ hold time for $\overline{\text{WE}}$	$t_{\text{CDH}}$	20	—	—	ns		
$\overline{\text{CDE}}$ setup time for SC	$t_{\text{CDSS}}$	1.5	—	—	$\mu\text{s}$		
$\overline{\text{CDE}}$ hold time for SC	$t_{\text{CDSH}}$	30	—	—	ns		
Next cycle ready time	$t_{\text{RDY}}$	0	—	—	ns		
$\overline{\text{CDE}}$ to $\overline{\text{OE}}$ hold time	$t_{\text{CDOH}}$	50	—	—	ns		
$\overline{\text{CDE}}$ to output delay	$t_{\text{CDAC}}$	—	—	50	ns		
$\overline{\text{CDE}}$ to output invalid	$t_{\text{CDF}}$	—	—	100	ns		
$\overline{\text{CE}}$ setup time for $\overline{\text{OE}}$	$t_{\text{COS}}$	0	—	—	ns		
$\overline{\text{CE}}$ hold time for $\overline{\text{OE}}$	$t_{\text{COH}}$	0	—	—	ns		
$\overline{\text{CDE}}$ to $\overline{\text{OE}}$ setup time	$t_{\text{CDOS}}$	20	—	—	ns		
$\overline{\text{OE}}$ setup time for SC	$t_{\text{OES}}$	0	—	—	ns		
$\overline{\text{OE}}$ low to output low-Z	$t_{\text{OEL}}$	0	—	40	ns		
SC to output delay	$t_{\text{SAC}}$	—	—	50	ns		
SC to output hold	$t_{\text{SH}}$	15	—	—	ns		
RDY/ $\overline{\text{Busy}}$ setup for SC	$t_{\text{RS}}$	200	—	—	ns		
$\overline{\text{CE}}$ hold time for $\overline{\text{WE}}$	$t_{\text{CWH}}$	1.0	—	—	$\mu\text{s}$		
$\overline{\text{CE}}$ hold time for $\overline{\text{WE}}$ on recovery read mode	$t_{\text{CWHR}}$	2	—	—	$\mu\text{s}$		
$\overline{\text{WE}}$ hold time for $\overline{\text{WE}}$	$t_{\text{WWH}}$	1	—	—	$\mu\text{s}$		
Busy time on read mode	$t_{\text{RBSY}}$	—	45	—	$\mu\text{s}$		

Note: 1.  $t_{\text{DF}}$  is a time after which the I/O pins become open.

Timing Waveforms

Power on and off Sequence

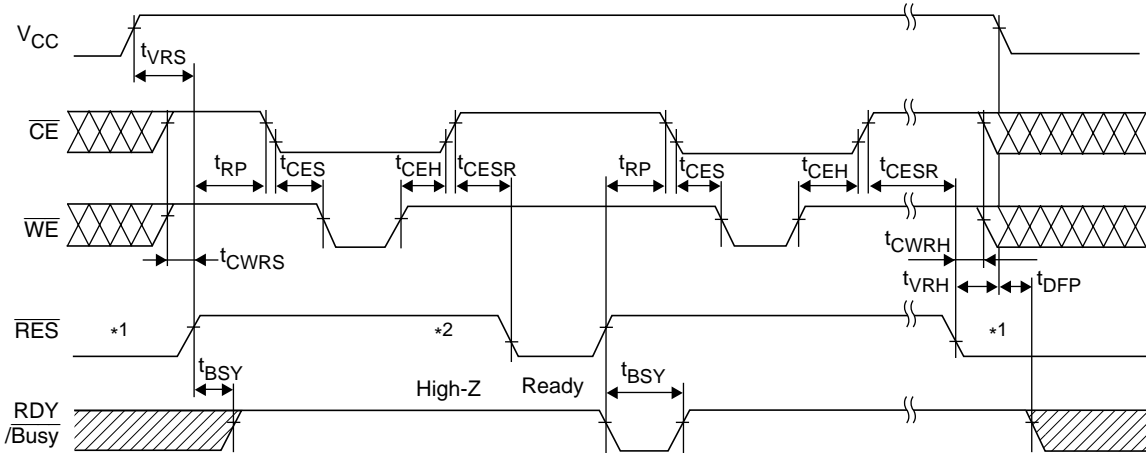

- Notes:
1.  $\overline{\text{RES}}$  must be kept at the  $V_{ILR}$  level referred to DC characteristics at the rising and falling edges of  $V_{CC}$  to guarantee data stored in the chip.
  2.  $\overline{\text{RES}}$  must be kept at the  $V_{IHR}$  level referred to DC characteristics while I/O7 outputs the  $V_{OL}$  level in the status data polling and RDY/Busy outputs the  $V_{OL}$  level.
  3.  : Undefined

## Serial Read (1) (2) Timing Waveform

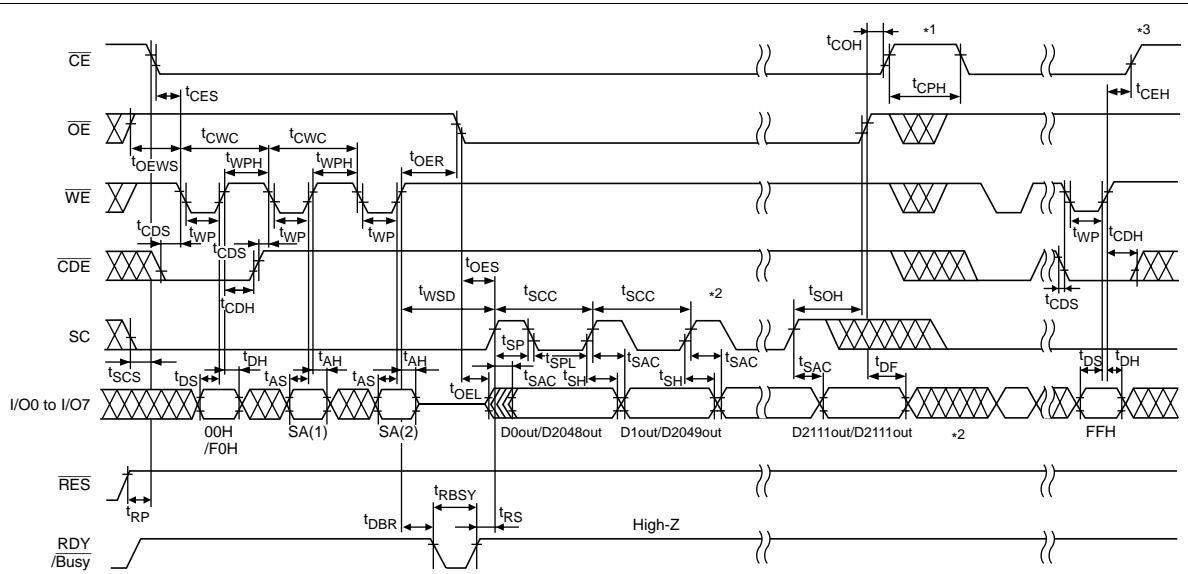

- Notes:
1. The status returns to the standby at the rising edge of  $\overline{CE}$ .
  2. Output data is not valid after the number of the SC pulse exceeds 2112 and 64 in the serial read mode (1) and (2), respectively.
  3. After any commands are written, the status can return to the standby after the command FFH is input and  $\overline{CE}$  turns to the  $V_{IH}$  level.

## Serial Read (1) with CA before SC Timing Waveform

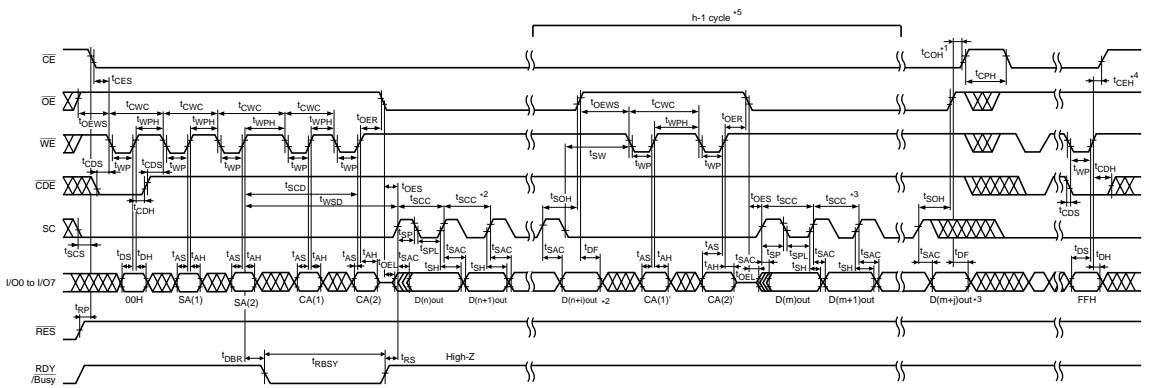

- Notes:
1. The status returns to the Standby at the rising edge of  $\overline{CE}$ .
  2. Output data is not valid after the number of the SC pulse exceeds  $(2112-n)$ . ( $i \leq 2111-n$ ,  $0 \leq n \leq 2111$ )
  3. Output data is not valid after the number of the SC pulse exceeds  $(2112-m)$ . ( $j \leq 2111-m$ ,  $0 \leq m \leq 2111$ )
  4. After any commands are written, the status can return to the standby after the command FFH is input and  $\overline{CE}$  turns to the  $V_{IH}$  level.
  5. This interval can be repeated  $(h-1)$  cycle. ( $1 \leq h \leq 2048 + 64$ )



## Program (1) and Status Data Polling Timing Waveform

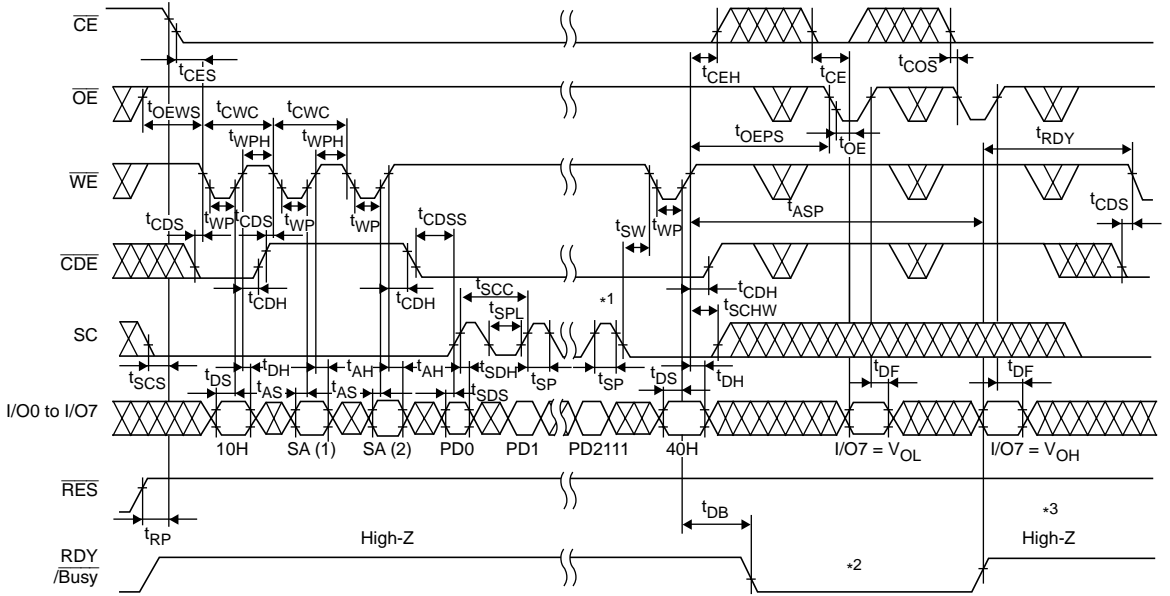

- Notes:
1. The programming operation is not guaranteed when the number of the SC pulse exceeds 2112.
  2. Any commands, including reset command FFH, cannot be input while RDY/Busy is  $V_{OL}$ .
  3. The status returns to the standby status after RDY/Busy returns to High-Z.
  4. By using program (1), data can be programmed additionally for each sector before erase.

Program (1) with CA before SC and Status Data Polling Timing Waveform

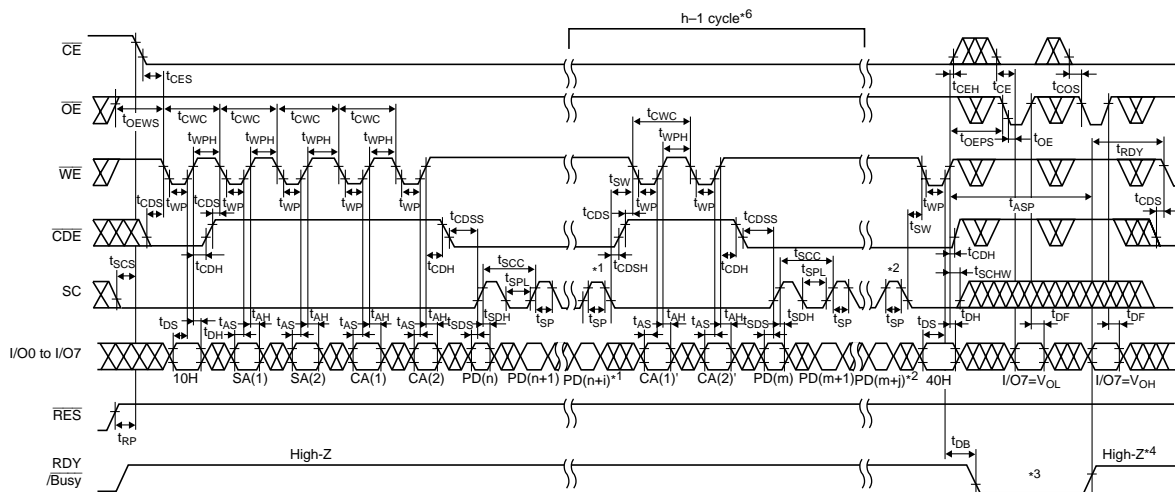

- Notes:
1. The programming operation is not guaranteed when the number of the SC pulse exceeds  $(2112 - n)$ . ( $i \leq 2111 - n$ ,  $0 \leq n \leq 2111$ )
  2. The programming operation is not guaranteed when the number of the SC pulse exceeds  $(2112 - m)$ . ( $j \leq 2111 - m$ ,  $0 \leq m \leq 2111$ )
  3. Any commands, including reset command FFH, cannot be input while RDY/Busy is  $V_{OL}$ .
  4. The status returns to the standby status after RDY/Busy returns to High-Z.
  5. By using program (1), data can be programmed additionally for each sector before erase.
  6. This interval can be repeated  $(h - 1)$  cycle. ( $1 \leq h \leq 2048 + 64$ )

Program (1) with CA after SC and Status Data Polling Timing Waveform

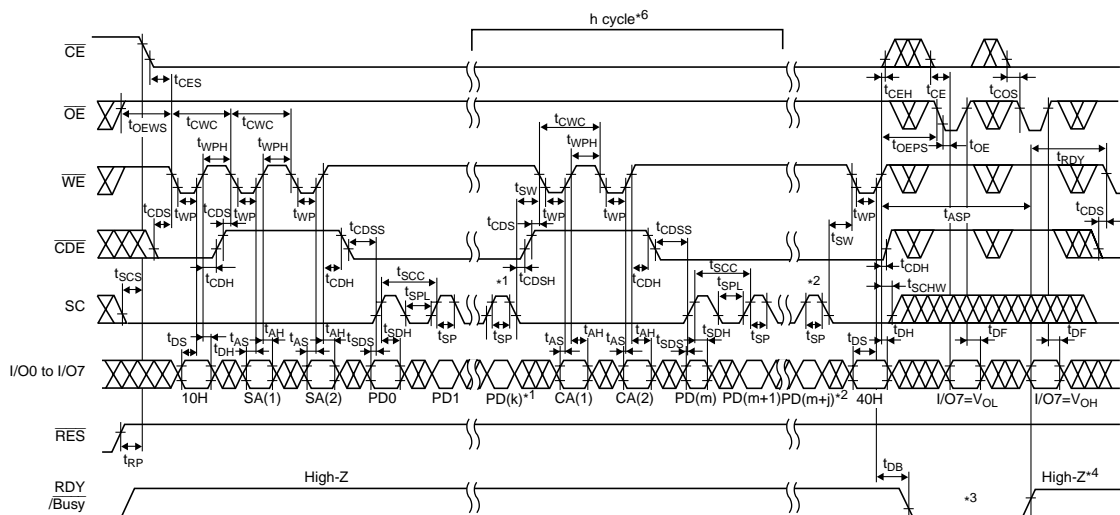

- Notes:
1. The programming operation is not guaranteed when the number of the SC pulse exceeds 2112. ( $0 \leq k \leq 2111$ )
  2. The programming operation is not guaranteed when the number of the SC pulse exceeds  $(2112 - m)$ . ( $j \leq 2111 - m$ ,  $0 \leq m \leq 2111$ )
  3. Any commands, including reset command FFH, cannot be input while RDY/Busy is  $V_{OL}$ .
  4. The status returns to the standby status after RDY/Busy returns to High-Z.
  5. By using program (1), data can be programmed additionally for each sector before erase.
  6. This interval can be repeated  $h$  cycle. ( $1 \leq h \leq 2048 + 64$ )

## Program (2) and Status Data Polling Timing Waveform

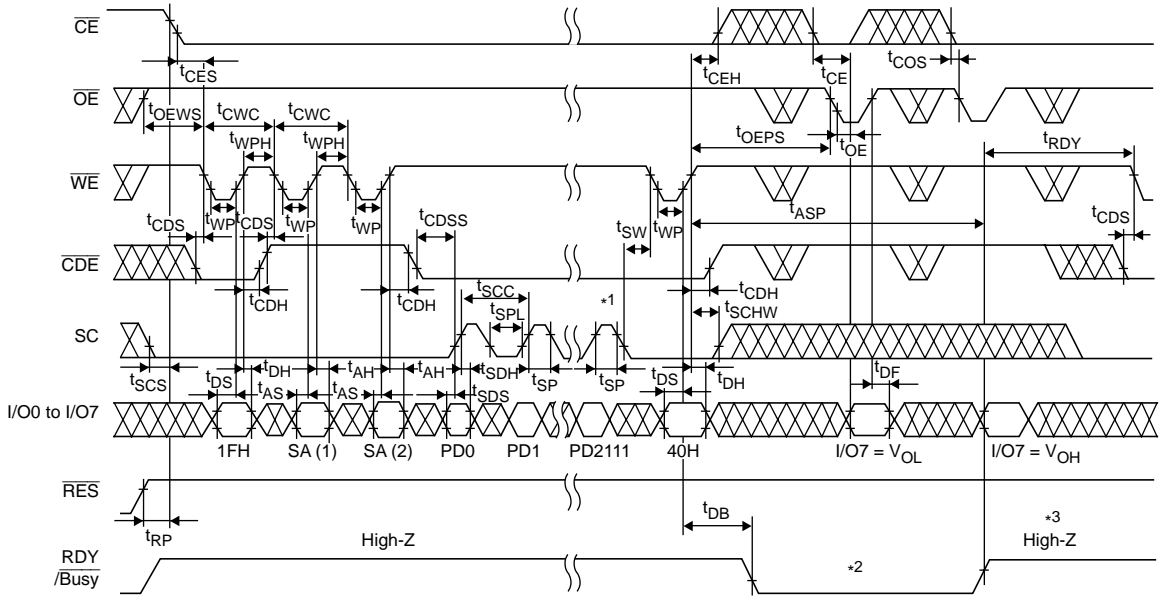

- Notes:
1. The programming operation is not guaranteed when the number of the SC pulse exceeds 2112.
  2. Any commands, including reset command FFH, cannot be input while RDY/Busy is  $V_{OL}$ .
  3. The status returns to the standby status after RDY/Busy returns to High-Z.
  4. By using program (2), the programmed data of each sector must be erased before programming next data.

Program (3) and Status Data Polling Timing Waveform

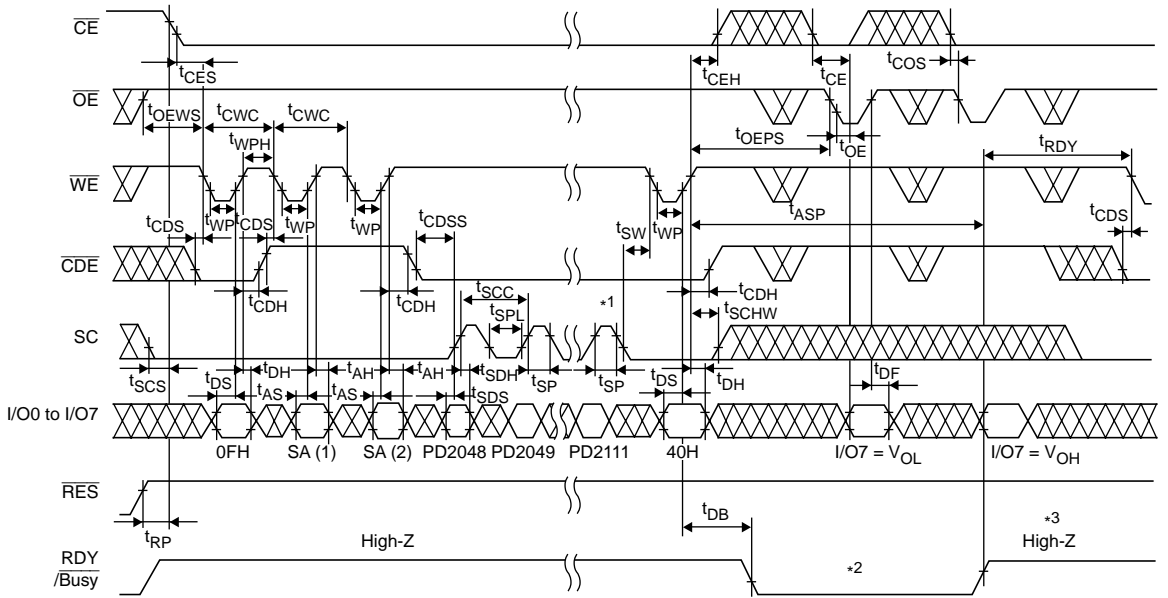

- Notes:
1. The programming operation is not guaranteed when the number of the SC pulse exceeds 64.
  2. Any commands, including reset command FFH, cannot be input while RDY/Busy is  $V_{OL}$ .
  3. The status returns to the standby status after RDY/Busy returns to High-Z.
  4. By using program (3), the data can be programmed additionally for each sector before erase.



Program (4) with CA before SC and Status Data Polling Timing Waveform

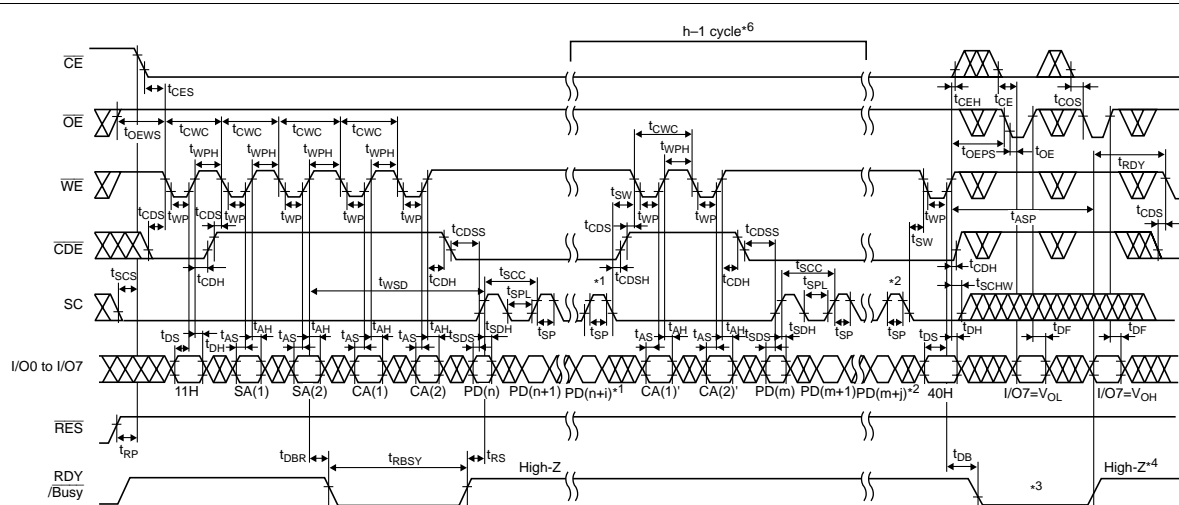

- Notes: 1. The programming operation is not guaranteed when the number of the SC pulse exceeds  $(2112 - n)$ ,  $(i \leq 2111 - n, 0 \leq n \leq 2111)$
- 2. The programming operation is not guaranteed when the number of the SC pulse exceeds  $(2112 - m)$ ,  $(j \leq 2111 - m, 0 \leq m \leq 2111)$
- 3. Any commands, including reset command FFH, cannot be input while RDY/Busy is  $V_{OL}$ .
- 4. The status returns to the standby status after RDY/Busy returns to High-Z.
- 5. By using program (4), data can be rewritten for each sector.
- 6. This interval can be repeated  $(h - 1)$  cycle,  $(1 \leq h \leq 2048 + 64)$

Program (4) with CA after SC and Status Data Polling Timing Waveform

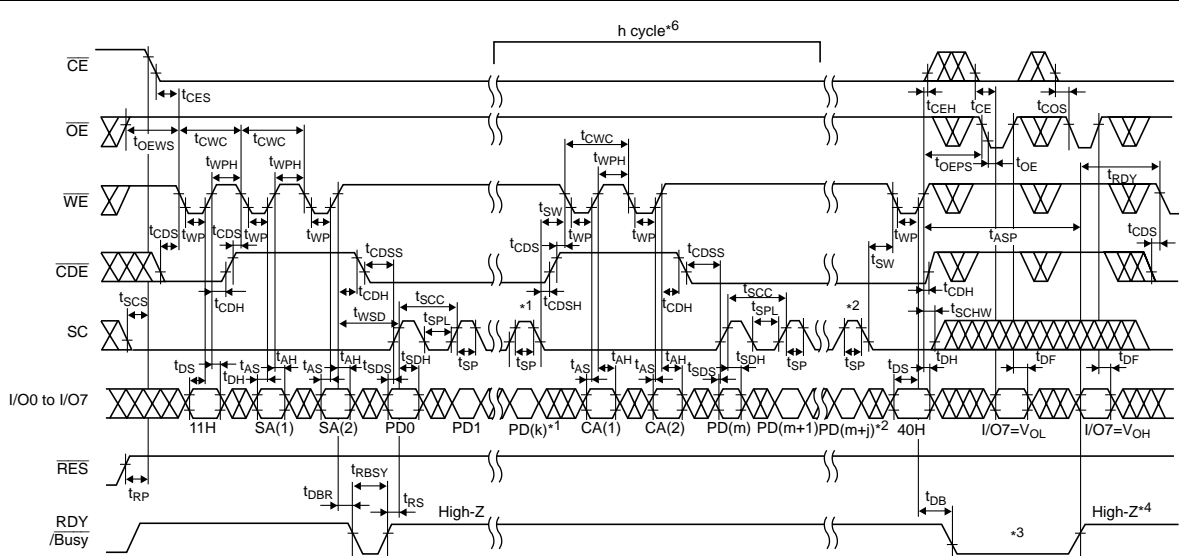

- Notes: 1. The programming operation is not guaranteed when the number of the SC pulse exceeds 2112,  $(0 \leq k \leq 2111)$
- 2. The programming operation is not guaranteed when the number of the SC pulse exceeds  $(2112 - m)$ ,  $(j \leq 2111 - m, 0 \leq m \leq 2111)$
- 3. Any commands, including reset command FFH, cannot be input while RDY/Busy is  $V_{OL}$ .
- 4. The status returns to the standby status after RDY/Busy returns to High-Z.
- 5. By using program (4), data can be rewritten for each sector.
- 6. This interval can be repeated h cycle,  $(1 \leq h \leq 2048 + 64)$

## ID and Status Register Read Timing Waveform

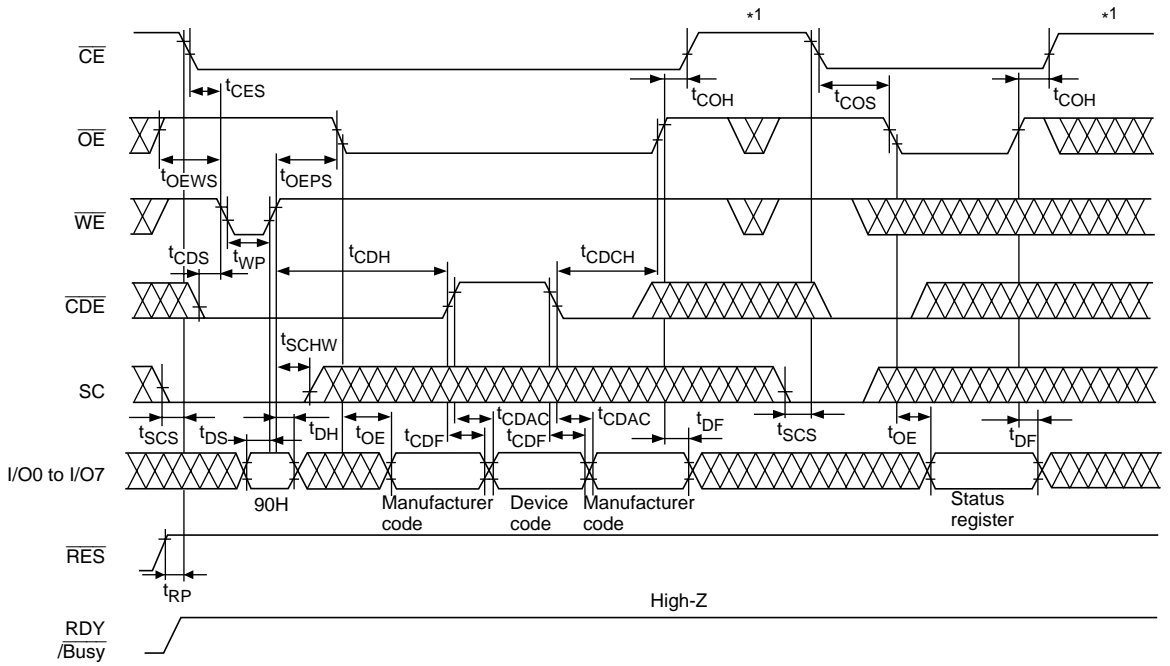

Note: 1. The status returns to the standby at the rising edge of  $\overline{CE}$ .

Data Recovery Read Timing Waveform

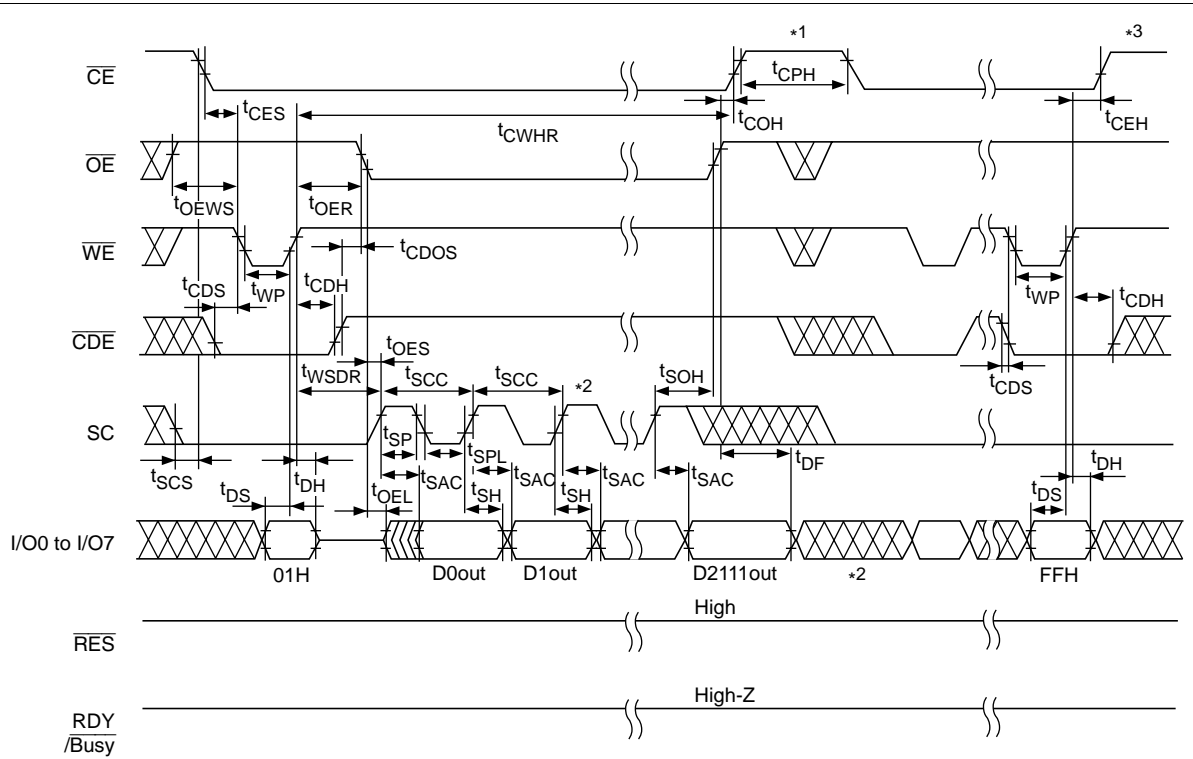

- Notes: 1. The status returns to the standby at the rising edge of  $\overline{CE}$ .
- 2. Output data is not valid after the number of the SC pulse exceed 2112 in the recovery data read mode.
- 3. After any commands are written, the status can turns to the standby after the command FFH is input and  $\overline{CE}$  turns to the  $V_{IH}$  level.

## Data Recovery Write Timing Waveform

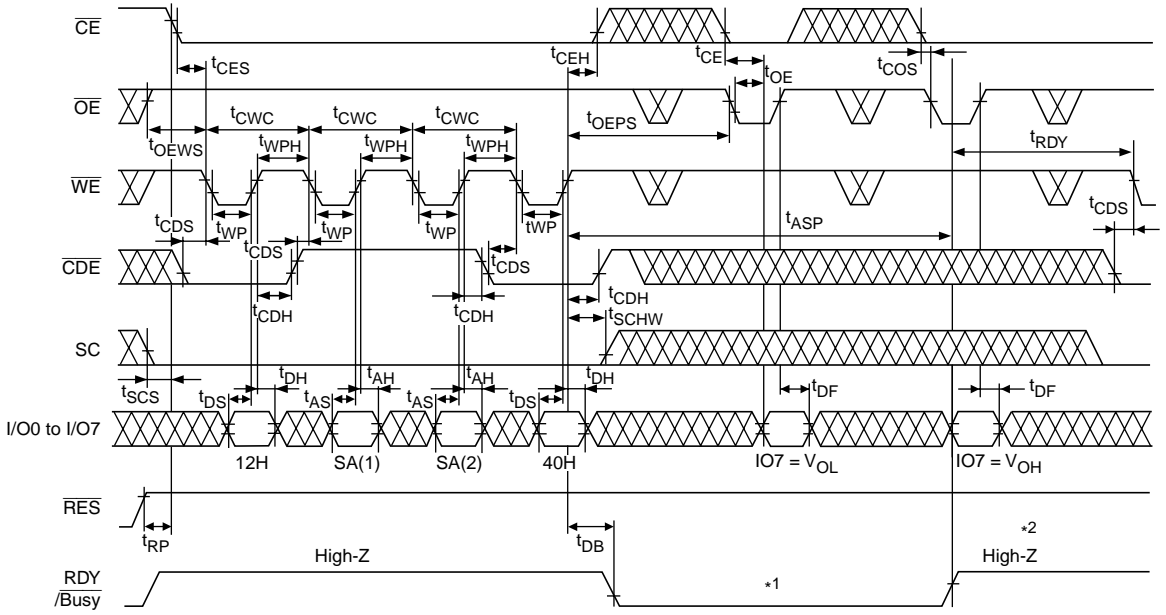

- Notes: 1. Any commands, including reset command FFH, cannot be input while RDY/Busy is V<sub>OL</sub>.  
 2. The status returns to the standby status after RDY/Busy returns to High-Z.

Clear Status Register Timing Waveform

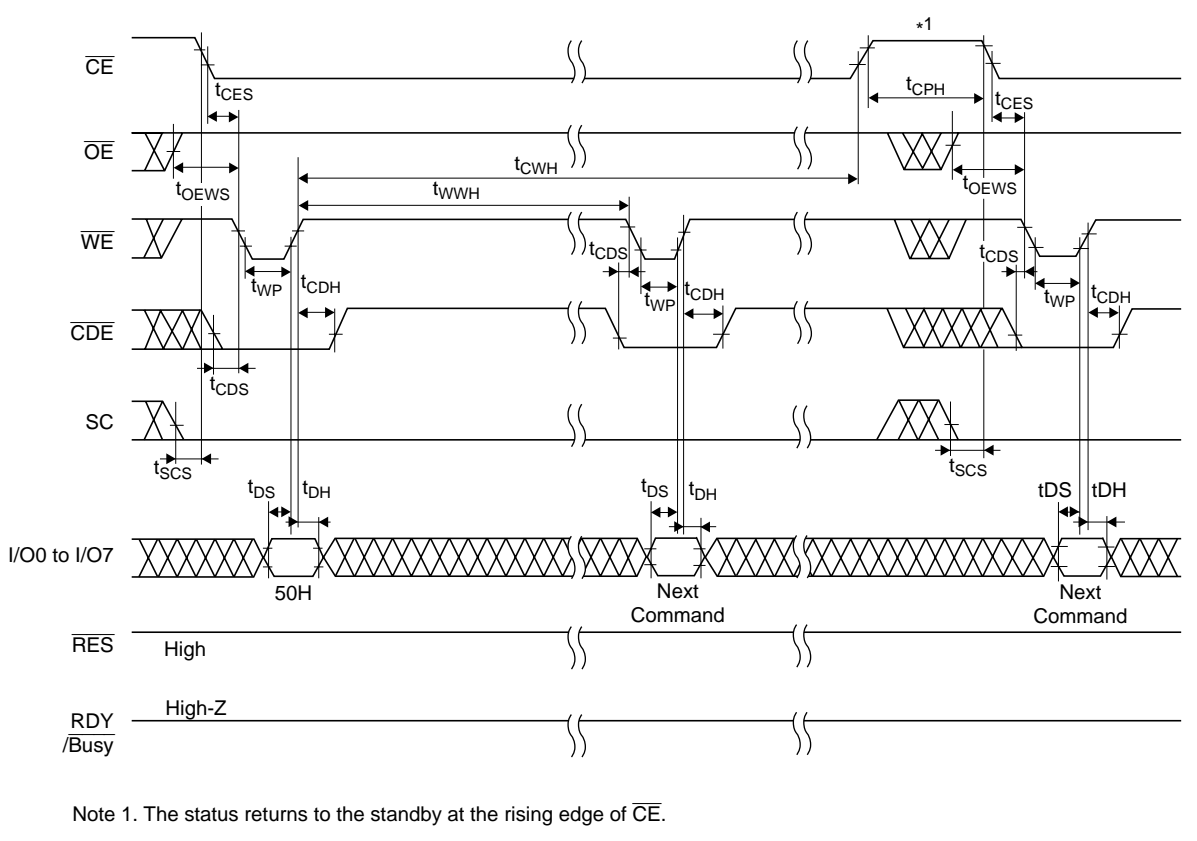

## Function Description

**Status Register:** The HN29W25611 outputs the operation status data as follows: I/O7 pin outputs a  $V_{OL}$  to indicate that the memory is in either erase or program operation. The level of I/O7 pin turns to a  $V_{OH}$  when the operation finishes. I/O5 and I/O4 pins output  $V_{OL}$ s to indicate that the erase and program operations complete in a finite time, respectively. If these pins output  $V_{OH}$ s, it indicates that these operations have timed out. When these pins monitor, I/O7 pin must turn to a  $V_{OH}$ . To execute other erase and program operation, the status data must be cleared after a time out occurs. From I/O0 to I/O3 pins are reserved for future use. The pins output  $V_{OL}$ s and should be masked out during the status data read mode. The function of the status register is summarized in the following table .

I/O	Flag definition	Definition
I/O7	Ready/ $\overline{\text{Busy}}$	$V_{OH}$ = Ready, $V_{OL}$ = Busy
I/O6	Reserved	Outputs a $V_{OL}$ and should be masked out during the status data polling mode.
I/O5	Erase check	$V_{OH}$ = Fail, $V_{OL}$ = Pass
I/O4	Program check	$V_{OH}$ = Fail, $V_{OL}$ = Pass
I/O3	Reserved	Outputs a $V_{OL}$ and should be masked out during the status data polling mode.
I/O2	Reserved	
I/O1	Reserved	
I/O0	Reserved	

## Requirement for System

### Specifications

Item	Min	Typ	Max	Unit
Usable sectors (initially)	16,057	—	16,384	sector
Spare sectors	290	—	—	sector
ECC (Error Correction Code)	3	—	—	bit/sector
Program/Erase endurance	—	—	$10^5$	cycle

**Unusable Sector**

Initially, the HN29W25611 includes unusable sectors. The unusable sectors must be distinguished from the usable sectors by the system as follows.

1. Check the partial invalid sectors in the devices on the system. The usable sectors were programmed the following data. Refer to the flowchart “Indication of unusable sectors”.

**Initial Data of Usable Sectors**

Column address	0H to 81FH	820H	821H	822H	823H	824H	825H	826H to 83FH
Data	FFH	1CH	71H	C7H	1CH	71H	C7H	FFH

2. Do not erase and program to the partial invalid sectors by the system.

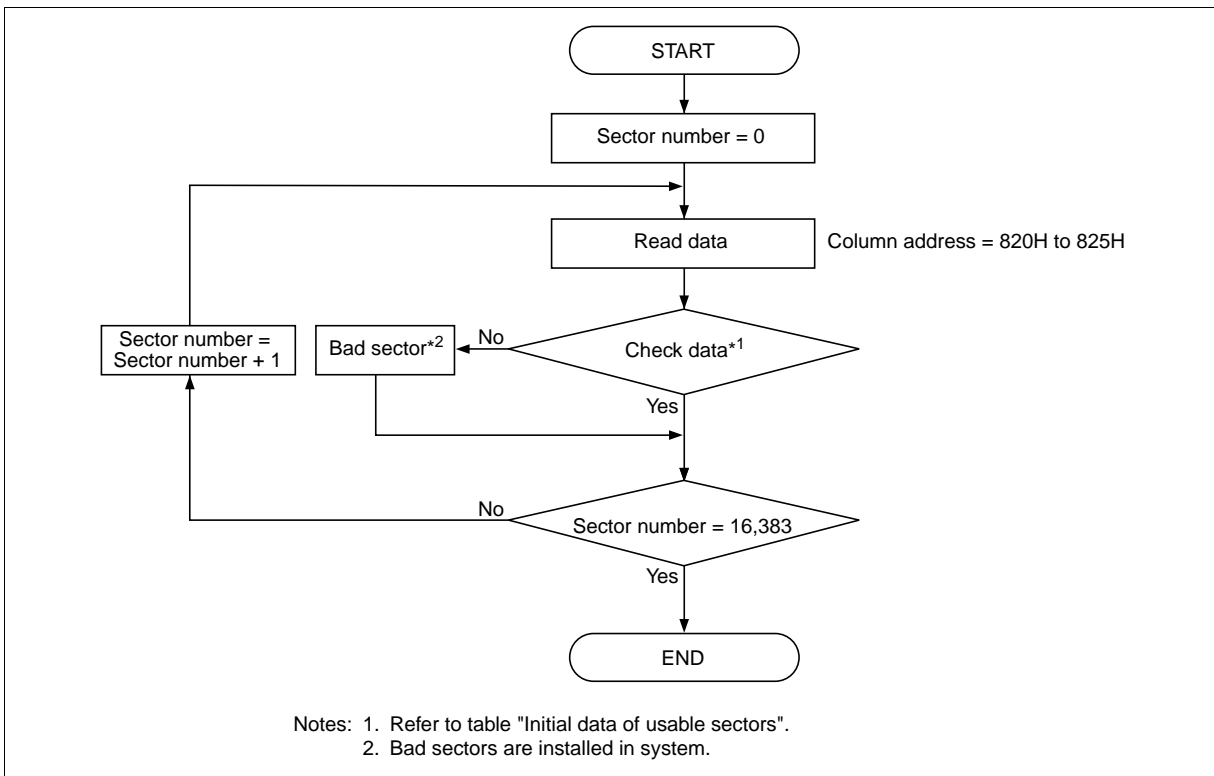

**Indication of Unusable Sectors**

## Requirements for High System Reliability

The device may fail during a program, erase or read operation due to write or erase cycles. The following architecture will enable high system reliability if a failure occurs.

1. For an error in read operation: An error correction more than 3-bit error correction per each sector read is required for data reliability.
2. For errors in program or erase operations: The device may fail during a program or erase operation due to write or erase cycles. The status register indicates if the erase and program operation complete in a finite time. When an error happens in the sector, try to reprogram the data into another sector. Avoid further system access to the sector that error happens. Typically, recommended number of a spare sectors are 1.8% of initial usable 16,057 sectors by each device. If the number of failed sectors exceeds the number of the spare sectors, usable data area in the device decreases. For the reprogramming, do not use the data from the failed sectors, because the data from the failed sectors are not fixed. So the reprogram data must be the data reloaded from outer buffer, or use the Data recovery read mode or the Data recovery write mode (see the “Mode Description” and under figure “Spare Sectors in Program Error”). To avoid consecutive sector failures, choose addresses of spare sectors as far as possible from the failed sectors.

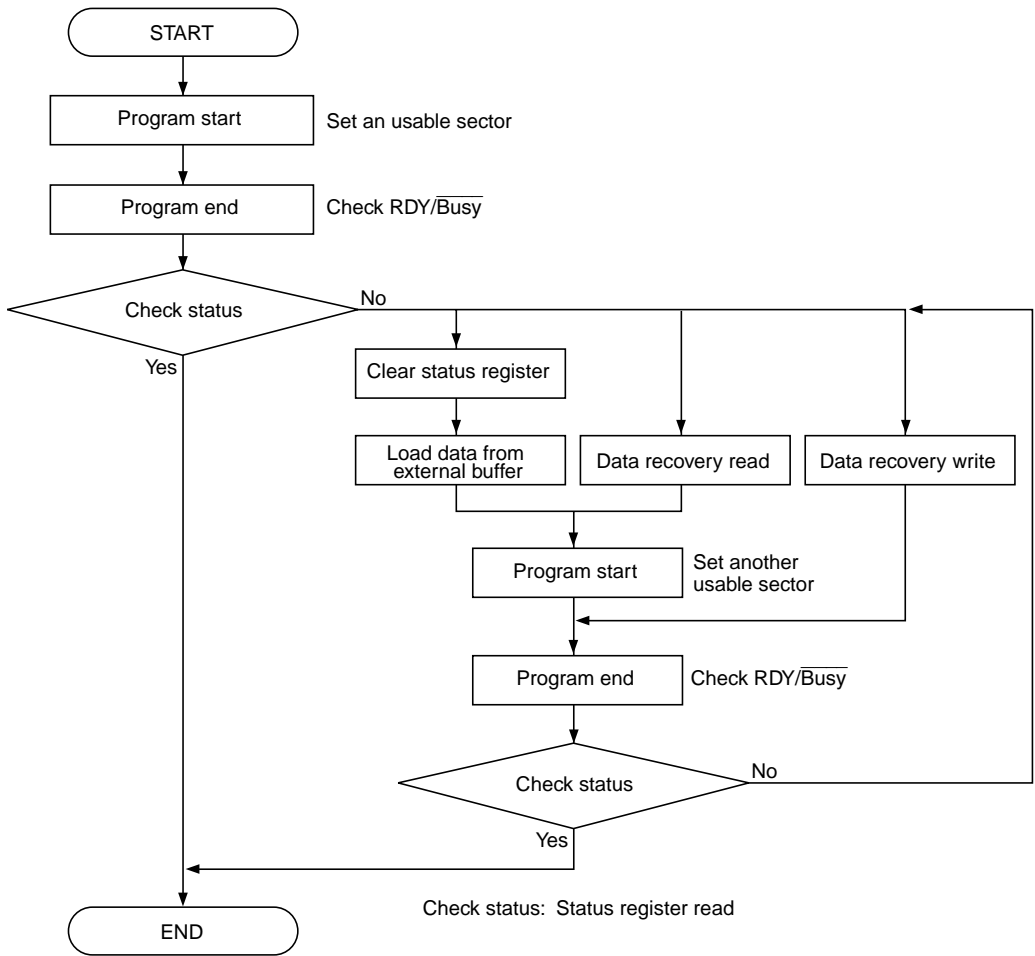

**Spare Sectors in Program Error**

## Memory Structure

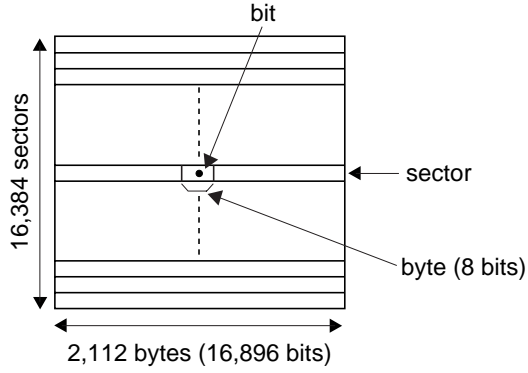

Bit: Minimum unit of data.

Byte: Input/output data unit in programming and reading. (1 byte = 8 bits)

Sector: Page unit in erase, programming and reading. (1 sector = 2,112 bytes = 16,896 bits)

Device: 1 device = 16,384 sectors.

Package Dimensions

HN29W25611T Series (TFP-48D)

Unit: mm

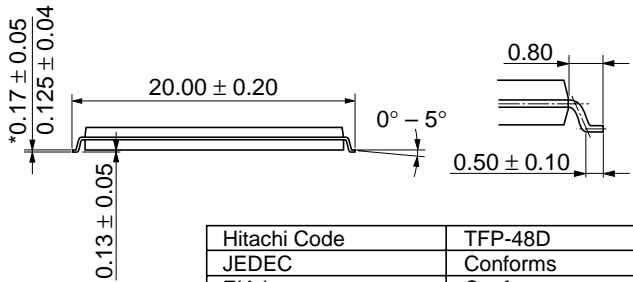
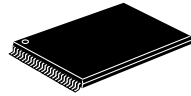
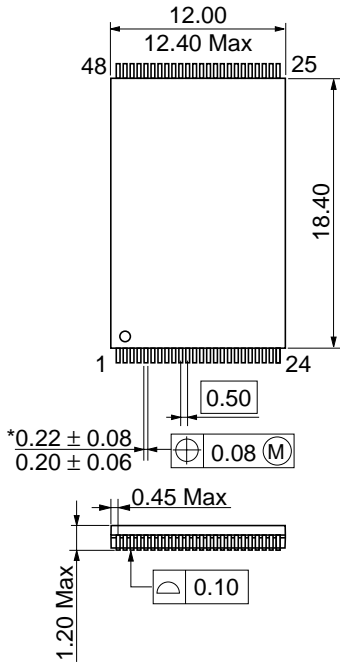

\*Dimension including the plating thickness  
Base material dimension

Hitachi Code	TFP-48D
JEDEC	Conforms
EIAJ	Conforms
Weight (reference value)	0.49 g

## Cautions

1. Hitachi neither warrants nor grants licenses of any rights of Hitachi's or any third party's patent, copyright, trademark, or other intellectual property rights for information contained in this document. Hitachi bears no responsibility for problems that may arise with third party's rights, including intellectual property rights, in connection with use of the information contained in this document.
2. Products and product specifications may be subject to change without notice. Confirm that you have received the latest product standards or specifications before final design, purchase or use.
3. Hitachi makes every attempt to ensure that its products are of high quality and reliability. However, contact Hitachi's sales office before using the product in an application that demands especially high quality and reliability or where its failure or malfunction may directly threaten human life or cause risk of bodily injury, such as aerospace, aeronautics, nuclear power, combustion control, transportation, traffic, safety equipment or medical equipment for life support.
4. Design your application so that the product is used within the ranges guaranteed by Hitachi particularly for maximum rating, operating supply voltage range, heat radiation characteristics, installation conditions and other characteristics. Hitachi bears no responsibility for failure or damage when used beyond the guaranteed ranges. Even within the guaranteed ranges, consider normally foreseeable failure rates or failure modes in semiconductor devices and employ systemic measures such as fail-safes, so that the equipment incorporating Hitachi product does not cause bodily injury, fire or other consequential damage due to operation of the Hitachi product.
5. This product is not designed to be radiation resistant.
6. No one is permitted to reproduce or duplicate, in any form, the whole or part of this document without written approval from Hitachi.
7. Contact Hitachi's sales office for any questions regarding this document or Hitachi semiconductor products.

# HITACHI

## Hitachi, Ltd.

Semiconductor & Integrated Circuits.

Nippon Bldg., 2-6-2, Ohite-machi, Chiyoda-ku, Tokyo 100-0004, Japan

Tel: Tokyo (03) 3270-2111 Fax: (03) 3270-5109

URL      NorthAmerica      : <http://semiconductor.hitachi.com/>  
Europe      : <http://www.hitachi-eu.com/hel/ecg>  
Asia (Singapore)      : <http://www.has.hitachi.com.sg/grp3/sicd/index.htm>  
Asia (Taiwan)      : [http://www.hitachi.com.tw/E/Product/SICD\\_Frame.htm](http://www.hitachi.com.tw/E/Product/SICD_Frame.htm)  
Asia (HongKong)      : <http://www.hitachi.com.hk/eng/bo/grp3/index.htm>  
Japan      : <http://www.hitachi.co.jp/Sicd/index.htm>

## For further information write to:

Hitachi Semiconductor  
(America) Inc.  
179 East Tasman Drive,  
San Jose, CA 95134  
Tel: <1> (408) 433-1990  
Fax: <1> (408) 433-0223

Hitachi Europe GmbH  
Electronic components Group  
Dornacher Straße 3  
D-85622 Feldkirchen, Munich  
Germany  
Tel: <49> (89) 9 9180-0  
Fax: <49> (89) 9 29 30 00

Hitachi Europe Ltd.  
Electronic Components Group.  
Whitebrook Park  
Lower Cookham Road  
Maidenhead  
Berkshire SL6 8YA, United Kingdom  
Tel: <44> (1628) 585000  
Fax: <44> (1628) 778322

Hitachi Asia Pte. Ltd.  
16 Collyer Quay #20-00  
Hitachi Tower  
Singapore 049318  
Tel: 535-2100  
Fax: 535-1533

Hitachi Asia Ltd.  
Taipei Branch Office  
3F, Hung Kuo Building, No.167,  
Tun-Hwa North Road, Taipei (105)  
Tel: <886> (2) 2718-3666  
Fax: <886> (2) 2718-8180

Hitachi Asia (Hong Kong) Ltd.  
Group III (Electronic Components)  
7/F., North Tower, World Finance Centre,  
Harbour City, Canton Road, Tsim Sha Tsui,  
Kowloon, Hong Kong  
Tel: <852> (2) 735 9218  
Fax: <852> (2) 730 0281  
Telex: 40815 HITEC HX

Copyright © Hitachi, Ltd., 1998. All rights reserved. Printed in Japan.

Revision Record

Rev.	Date	Contents of Modification	Drawn by	Approved by
0.0	Jan. 8, 1999	Initial issue	M. Shirai	T. Totsuka
0.1	Jun. 28, 1999	<p>Deletion of <math>V_{CC} = 5.0 V \pm 0.5 V</math> operation</p> <p>Sector program time: 1.0 ms to 3.0 ms</p> <p>Single sector erase time: 1.0 ms to 1.5 ms</p> <p>Error correction: more than 1 bit... to more than 3-bit...</p> <p>Command Definition: Addition of Data recovery read item</p> <p>Addition of description for Data recovery read</p> <p>Change of Status transition</p> <p>AC Characteristics</p> <p>Change of parameter name: <math>t_{OEPS}</math> to <math>t_{OER}</math></p> <p><math>t_{OER}</math> min: 200 ns to 250 ns</p> <p><math>t_{OEPS}</math> min: 200 ns to 40 ns</p> <p><math>t_{ASE}</math> typ: 1.0 ms to 1.5 ms</p> <p><math>t_{ASE}</math> (Program1, 3) typ: 1.5 ms to 3.0 ms</p> <p><math>t_{ASE}</math> (Program1, 3) max: 37.0 ms to 20.0 ms</p> <p><math>t_{ASE}</math> (Program2) typ: 1.0 ms to 2.5 ms</p> <p><math>t_{ASE}</math> (Program2) max: 35.0 ms to 20.0 ms</p> <p><math>t_{ASE}</math> (Program3) typ: 2.0 ms to 3.5 ms</p> <p><math>t_{ASE}</math> (Program3) max: 40.0 ms to 30.0 ms</p> <p><math>t_{CDSH}</math> min: 0 ns to 30 ns</p> <p><math>t_{OEL}</math> min: — to 40 ns</p> <p>Change of Timing Waveforms</p> <p>Serial read (1) (2), Serial read (1) with CA before SC, Serial read (1) with CA after SC and Data recovery read</p> <p>Notes</p> <p>Change of description for Enable high system reliability 1</p> <p>Deletion of description for Enable high system reliability 3 and Prohibit the command except command definition</p>	M. Shirai	H. Uchida
1.0	Dec. 10, 1999	<p>Features: Change of required architecture</p> <p>Change of table for Command definition</p> <p>Mode Description</p> <p>Addition of description for Data Recovery Write</p> <p>Addition of figure for Data Recovery Write</p> <p>Change of Status Transition</p> <p>Timing Waveforms: Addition of Data Recovery Write</p> <p>Notes: Change all item</p> <p>Addition of flowcharts</p> <p>Change of contents</p> <p>Addition of Memory structure</p>		

This datasheet has been downloaded from:

[www.DatasheetCatalog.com](http://www.DatasheetCatalog.com)

Datasheets for electronic components.



LittleDiode supplies new, hard to find or obsolete electronic components and semiconductors all over the world.

With over two million different components listed you are sure to find the part you need.

Feel free to visit us today at our online store:

[LittleDiode.com](http://LittleDiode.com)

Looking forward to providing you with the best possible service.