

---

# HN58C1001 Series

1M EEPROM (128-kword × 8-bit)  
Ready/Busy and  $\overline{\text{RES}}$  function

REJ03C0145-0800Z  
(Previous ADE-203-028G (Z) Rev.7.0)  
Rev. 8.00  
Nov. 27. 2003

---

## Description

Renesas Technology's HN58C1001 is an electrically erasable and programmable ROM organized as 131072-word × 8-bit. It has realized high speed, low power consumption and high reliability by employing advanced MNOS memory technology and CMOS process and circuitry technology. It also has a 128-byte page programming function to make the write operations faster.

## Features

- Single supply: 5.0 V ± 10%
- Access time: 150 ns (max)
- Power dissipation
  - Active: 20 mW/MHz, (typ)
  - Standby: 110 μW (max)
- On-chip latches: address, data,  $\overline{\text{CE}}$ ,  $\overline{\text{OE}}$ ,  $\overline{\text{WE}}$
- Automatic byte write: 10 ms (max)
- Automatic page write (128 bytes): 10 ms (max)
- $\overline{\text{Data}}$  polling and  $\overline{\text{RDY/Busy}}$
- Data protection circuit on power on/off
- Conforms to JEDEC byte-wide standard
- Reliable CMOS with MNOS cell technology
- 10<sup>4</sup> erase/write cycles (in page mode)
- 10 years data retention
- Software data protection
- Write protection by  $\overline{\text{RES}}$  pin
- There are also lead free products.

## HN58C1001 Series

### Ordering Information

Type No.	Access time	Package
HN58C1001FP-15	150 ns	525 mil 32-pin plastic SOP (FP-32D)
HN58C1001T-15	150 ns	32-pin plastic TSOP (TFP-32DA)
HN58C1001FP-15E	150 ns	525 mil 32-pin plastic SOP (FP-32DV) Lead free
HN58C1001T-15E	150 ns	32-pin plastic TSOP (TFP-32DAV) Lead free

### Pin Arrangement

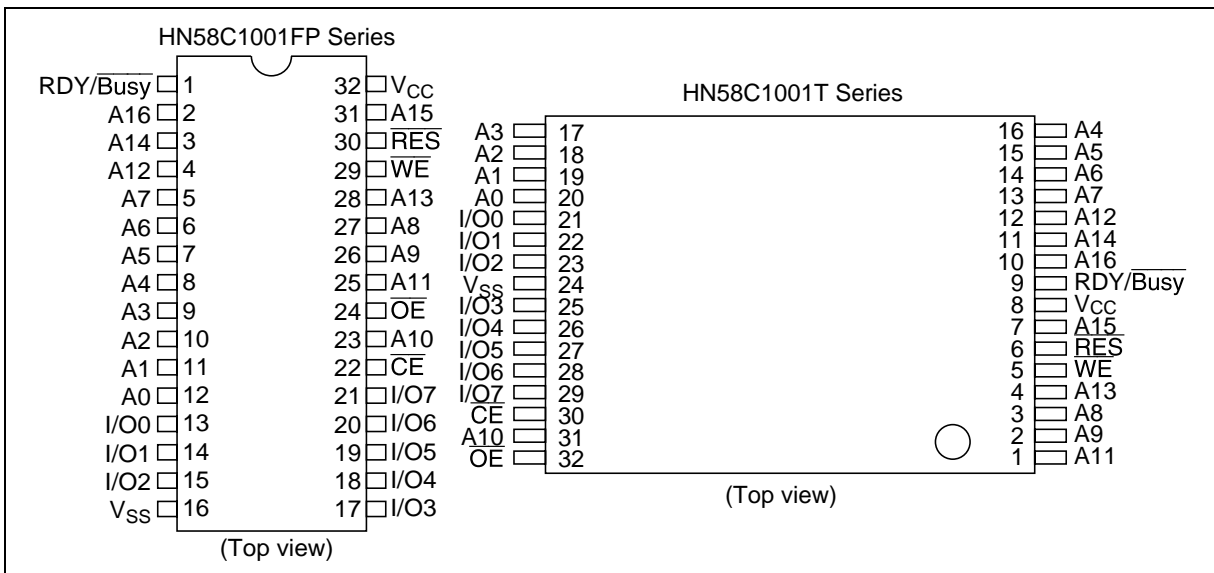

**Pin Description**

Pin name	Function
A0 to A16	Address input
I/O0 to I/O7	Data input/output
$\overline{OE}$	Output enable
$\overline{CE}$	Chip enable
$\overline{WE}$	Write enable
$V_{CC}$	Power supply
$V_{SS}$	Ground
RDY/Busy	Ready busy
$\overline{RES}$	Reset

**Block Diagram**

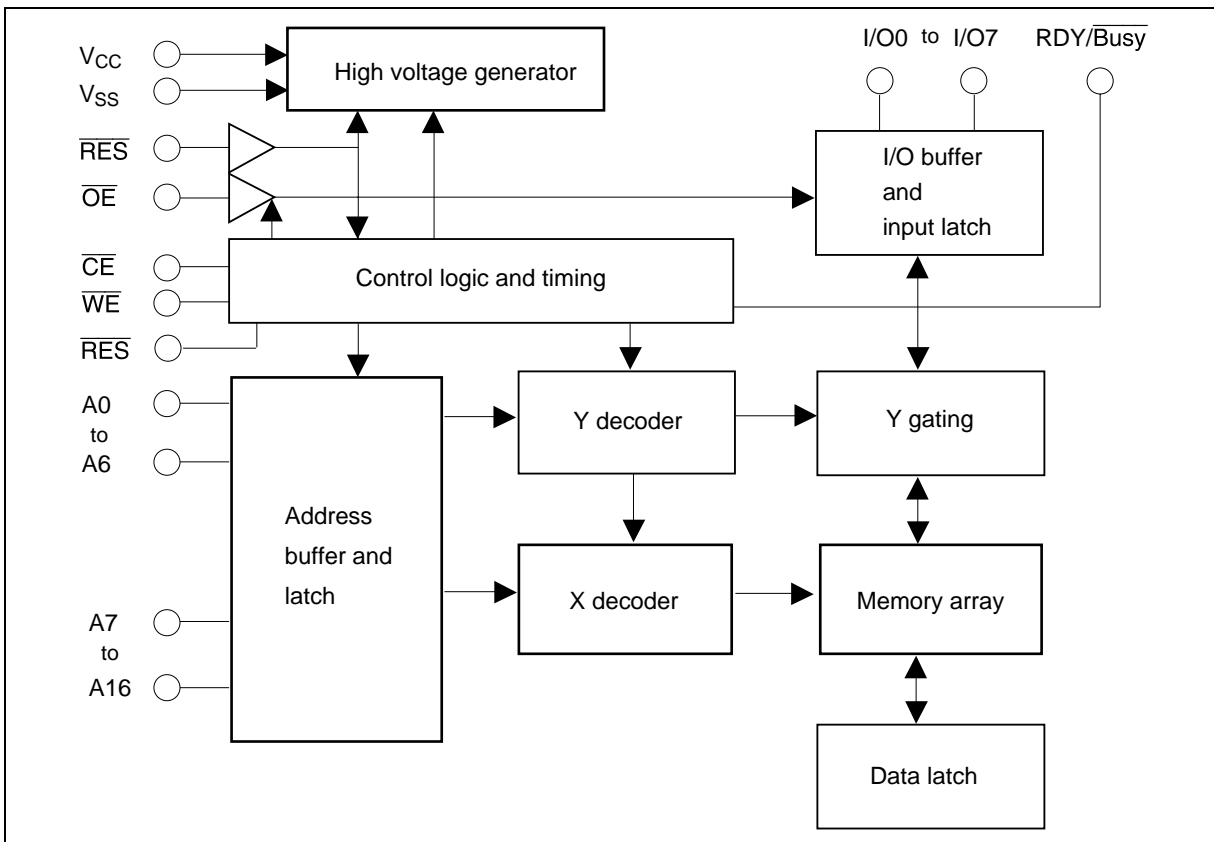

**Operation Table**

Operation	$\overline{CE}$	$\overline{OE}$	$\overline{WE}$	$\overline{RES}$	$\overline{RDY/Busy}$	I/O
Read	$V_{IL}$	$V_{IL}$	$V_{IH}$	$V_H^{*1}$	High-Z	Dout
Standby	$V_{IH}$	$\times^{*2}$	$\times$	$\times$	High-Z	High-Z
Write	$V_{IL}$	$V_{IH}$	$V_{IL}$	$V_H$	High-Z to $V_{OL}$	Din
Deselect	$V_{IL}$	$V_{IH}$	$V_{IH}$	$V_H$	High-Z	High-Z
Write Inhibit	$\times$	$\times$	$V_{IH}$	$\times$	—	—
	$\times$	$V_{IL}$	$\times$	$\times$	—	—
Data Polling	$V_{IL}$	$V_{IL}$	$V_{IH}$	$V_H$	$V_{OL}$	Dout (I/O7)
Program reset	$\times$	$\times$	$\times$	$V_{IL}$	High-Z	High-Z

Notes: 1. Refer to the recommended DC operating conditions.  
 2.  $\times$ : Don't care

**Absolute Maximum Ratings**

Parameter	Symbol	Value	Unit
Supply voltage relative to $V_{SS}$	$V_{CC}$	-0.6 to +7.0	V
Input voltage relative to $V_{SS}$	$V_{in}$	-0.5 <sup>*1</sup> to +7.0	V
Operating temperature range <sup>*2</sup>	$T_{opr}$	0 to +70	°C
Storage temperature range	$T_{stg}$	-55 to +125	°C

Notes: 1.  $V_{in}$  min = -3.0 V for pulse width  $\leq$  50 ns  
 2. Including electrical characteristics and data retention

**Recommended DC Operating Conditions**

Parameter	Symbol	Min	Typ	Max	Unit
Supply voltage	$V_{CC}$	4.5	5.0	5.5	V
	$V_{SS}$	0	0	0	V
Input voltage	$V_{IL}$	-0.3 <sup>*1</sup>	—	0.8	V
	$V_{IH}$	2.2	—	$V_{CC} + 0.3$	V
	$V_H$	$V_{CC} - 0.5$	—	$V_{CC} + 1.0$	V
Operating temperature	$T_{opr}$	0	—	+70	°C

Note: 1.  $V_{IL}$  (min): -1.0 V for pulse width  $\leq$  50 ns

## HN58C1001 Series

### DC Characteristics (Ta = 0 to +70°C, V<sub>CC</sub> = 5.0V ± 10%)

Parameter	Symbol	Min	Typ	Max	Unit	Test conditions
Input leakage current	I <sub>LI</sub>	—	—	2* <sup>1</sup>	μA	V <sub>CC</sub> = 5.5 V, Vin = 5.5 V
Output leakage current	I <sub>LO</sub>	—	—	2	μA	V <sub>CC</sub> = 5.5 V, Vout = 5.5/0.4 V
Standby V <sub>CC</sub> current	I <sub>CC1</sub>	—	—	20	μA	$\overline{CE} = V_{CC}$
	I <sub>CC2</sub>	—	—	1	mA	$\overline{CE} = V_{IH}$
Operating V <sub>CC</sub> current	I <sub>CC3</sub>	—	—	15	mA	I <sub>out</sub> = 0 mA, Duty = 100%, Cycle = 1 μs, V <sub>CC</sub> = 5.5 V
		—	—	50	mA	I <sub>out</sub> = 0 mA, Duty = 100%, Cycle = 150 ns, V <sub>CC</sub> = 5.5 V
Output low voltage	V <sub>OL</sub>	—	—	0.4	V	I <sub>OL</sub> = 2.1 mA
Output high voltage	V <sub>OH</sub>	2.4	—	—	V	I <sub>OH</sub> = -400 μA

Notes: 1. I<sub>LI</sub> on  $\overline{RES}$ : 100 μA (max)

### Capacitance (Ta = +25°C, f = 1 MHz)

Parameter	Symbol	Min	Typ	Max	Unit	Test conditions
Input capacitance* <sup>1</sup>	Cin	—	—	6	pF	Vin = 0 V
Output capacitance* <sup>1</sup>	Cout	—	—	12	pF	Vout = 0 V

Note: 1. This parameter is periodically sampled and not 100% tested.

## HN58C1001 Series

---

### AC Characteristics (Ta = 0 to +70°C, V<sub>CC</sub> = 5.0 V ± 10%)

#### Test Conditions

- Input pulse levels: 0.4 V to 2.4 V  
0 V to V<sub>CC</sub> ( $\overline{\text{RES}}$  pin)
- Input rise and fall time: ≤ 20 ns
- Output load: 1TTL Gate +100 pF
- Reference levels for measuring timing: 0.8 V, 2.0 V

#### Read Cycle

Parameter	Symbol	HN58C1001-15		Unit	Test conditions
		Min	Max		
Address to output delay	t <sub>ACC</sub>	—	150	ns	$\overline{\text{CE}} = \overline{\text{OE}} = V_{\text{IL}}, \overline{\text{WE}} = V_{\text{IH}}$
$\overline{\text{CE}}$ to output delay	t <sub>CE</sub>	—	150	ns	$\overline{\text{OE}} = V_{\text{IL}}, \overline{\text{WE}} = V_{\text{IH}}$
$\overline{\text{OE}}$ to output delay	t <sub>OE</sub>	10	75	ns	$\overline{\text{CE}} = V_{\text{IL}}, \overline{\text{WE}} = V_{\text{IH}}$
Address to output hold	t <sub>OH</sub>	0	—	ns	$\overline{\text{CE}} = \overline{\text{OE}} = V_{\text{IL}}, \overline{\text{WE}} = V_{\text{IH}}$
$\overline{\text{OE}}$ ( $\overline{\text{CE}}$ ) high to output float* <sup>1</sup>	t <sub>DF</sub>	0	50	ns	$\overline{\text{CE}} = V_{\text{IL}}, \overline{\text{WE}} = V_{\text{IH}}$
$\overline{\text{RES}}$ low to output float* <sup>1</sup>	t <sub>DFR</sub>	0	350	ns	$\overline{\text{CE}} = \overline{\text{OE}} = V_{\text{IL}}, \overline{\text{WE}} = V_{\text{IH}}$
$\overline{\text{RES}}$ to output delay	t <sub>RR</sub>	0	450	ns	$\overline{\text{CE}} = \overline{\text{OE}} = V_{\text{IL}}, \overline{\text{WE}} = V_{\text{IH}}$

## HN58C1001 Series

### Write Cycle

Parameter	Symbol	Min* <sup>2</sup>	Typ	Max	Unit	Test conditions
Address setup time	$t_{AS}$	0	—	—	ns	
Address hold time	$t_{AH}$	150	—	—	ns	
$\overline{CE}$ to write setup time ( $\overline{WE}$ controlled)	$t_{CS}$	0	—	—	ns	
$\overline{CE}$ hold time ( $\overline{WE}$ controlled)	$t_{CH}$	0	—	—	ns	
$\overline{WE}$ to write setup time ( $\overline{CE}$ controlled)	$t_{WS}$	0	—	—	ns	
$\overline{WE}$ hold time ( $\overline{CE}$ controlled)	$t_{WH}$	0	—	—	ns	
$\overline{OE}$ to write setup time	$t_{OES}$	0	—	—	ns	
$\overline{OE}$ hold time	$t_{OEH}$	0	—	—	ns	
Data setup time	$t_{DS}$	100	—	—	ns	
Data hold time	$t_{DH}$	10	—	—	ns	
$\overline{WE}$ pulse width ( $\overline{WE}$ controlled)	$t_{WP}$	250	—	—	ns	
$\overline{CE}$ pulse width ( $\overline{CE}$ controlled)	$t_{CW}$	250	—	—	ns	
Data latch time	$t_{DL}$	300	—	—	ns	
Byte load cycle	$t_{BLC}$	0.55	—	30	$\mu$ s	
Byte load window	$t_{BL}$	100	—	—	$\mu$ s	
Write cycle time	$t_{WC}$	—	—	10* <sup>3</sup>	ms	
Time to device busy	$t_{DB}$	120	—	—	ns	
Write start time	$t_{DW}$	150* <sup>4</sup>	—	—	ns	
Reset protect time	$t_{RP}$	100	—	—	$\mu$ s	
Reset high time* <sup>5</sup>	$t_{RES}$	1	—	—	$\mu$ s	

- Notes:
- $t_{DF}$  and  $t_{DFR}$  are defined as the time at which the outputs achieve the open circuit conditions and are no longer driven.
  - Use this device in longer cycle than this value.
  - $t_{WC}$  must be longer than this value unless polling techniques or  $\overline{RDY}/\overline{Busy}$  are used. This device automatically completes the internal write operation within this value.
  - Next read or write operation can be initiated after  $t_{DW}$  if polling techniques or  $\overline{RDY}/\overline{Busy}$  are used.
  - This parameter is sampled and not 100% tested.
  - A7 to A16 are page addresses and must be same within the page write operation.
  - See AC read characteristics.

### Timing Waveforms

#### Read Timing Waveform

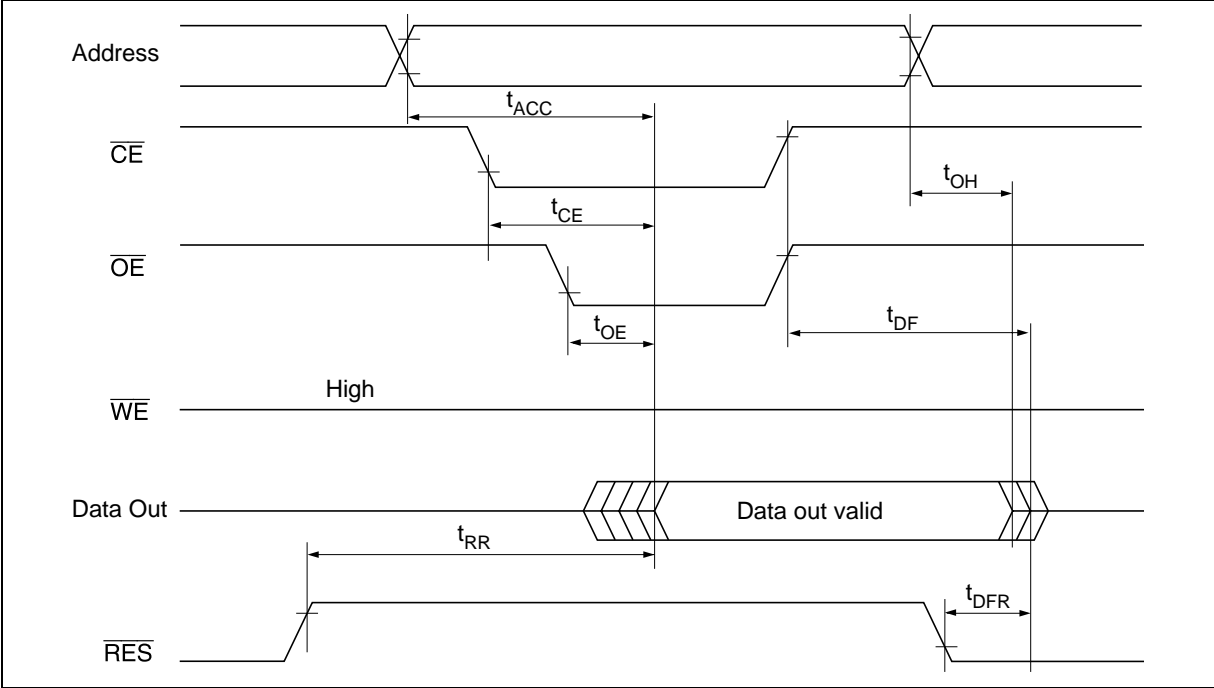

Byte Write Timing Waveform (1) ( $\overline{WE}$  Controlled)

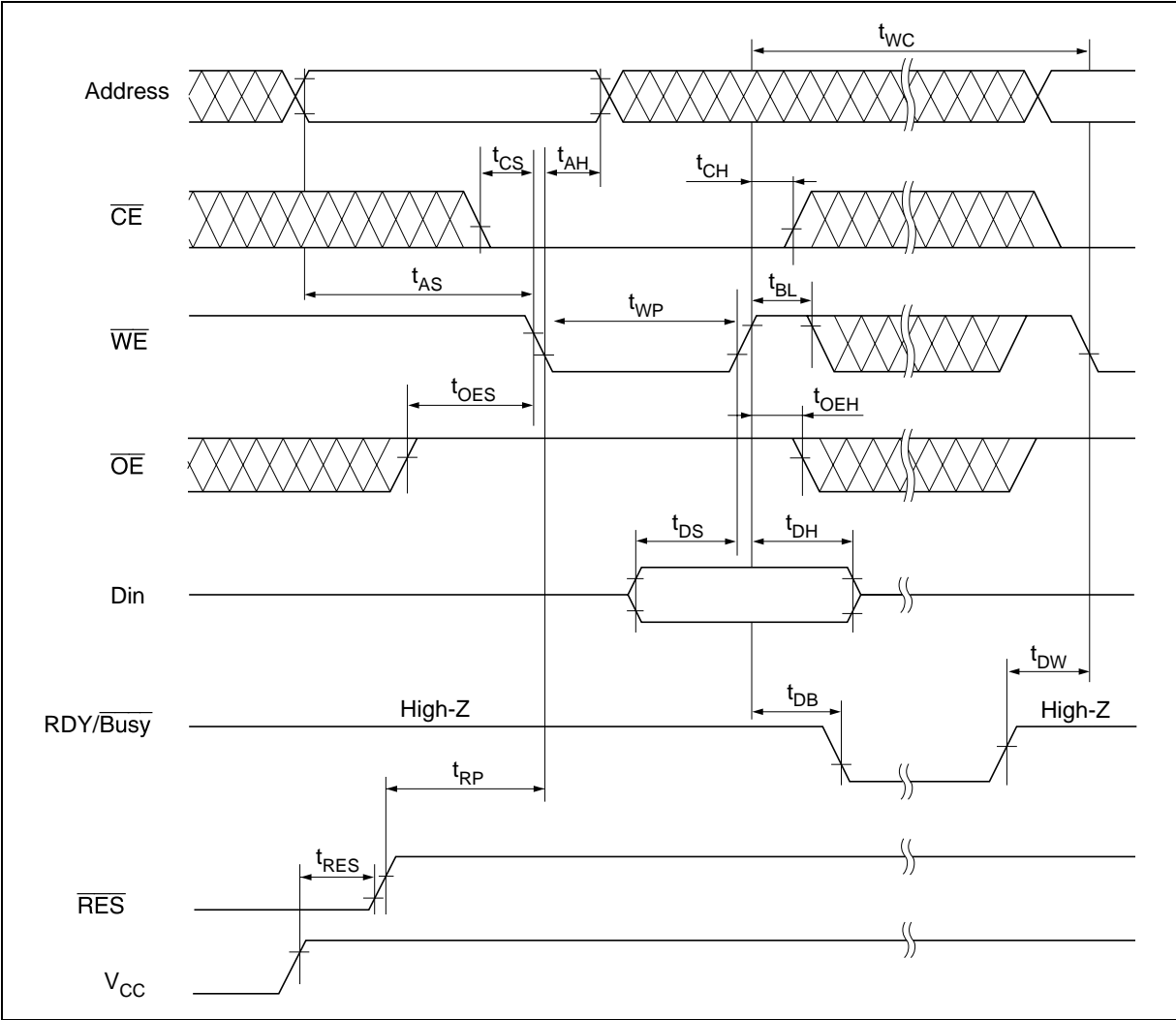

Byte Write Timing Waveform (2) ( $\overline{\text{CE}}$  Controlled)

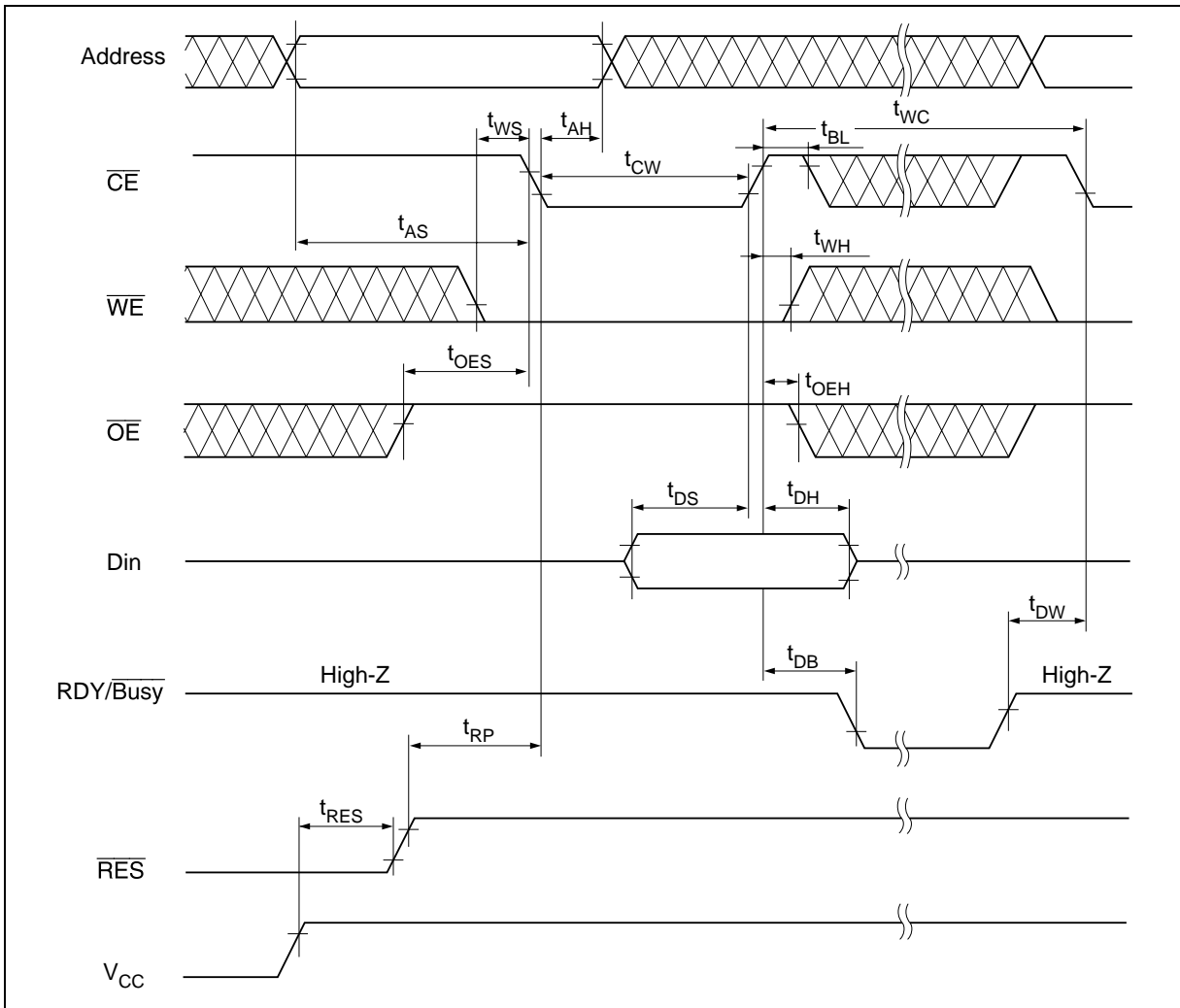

Page Write Timing Waveform (1) ( $\overline{\text{WE}}$  Controlled)

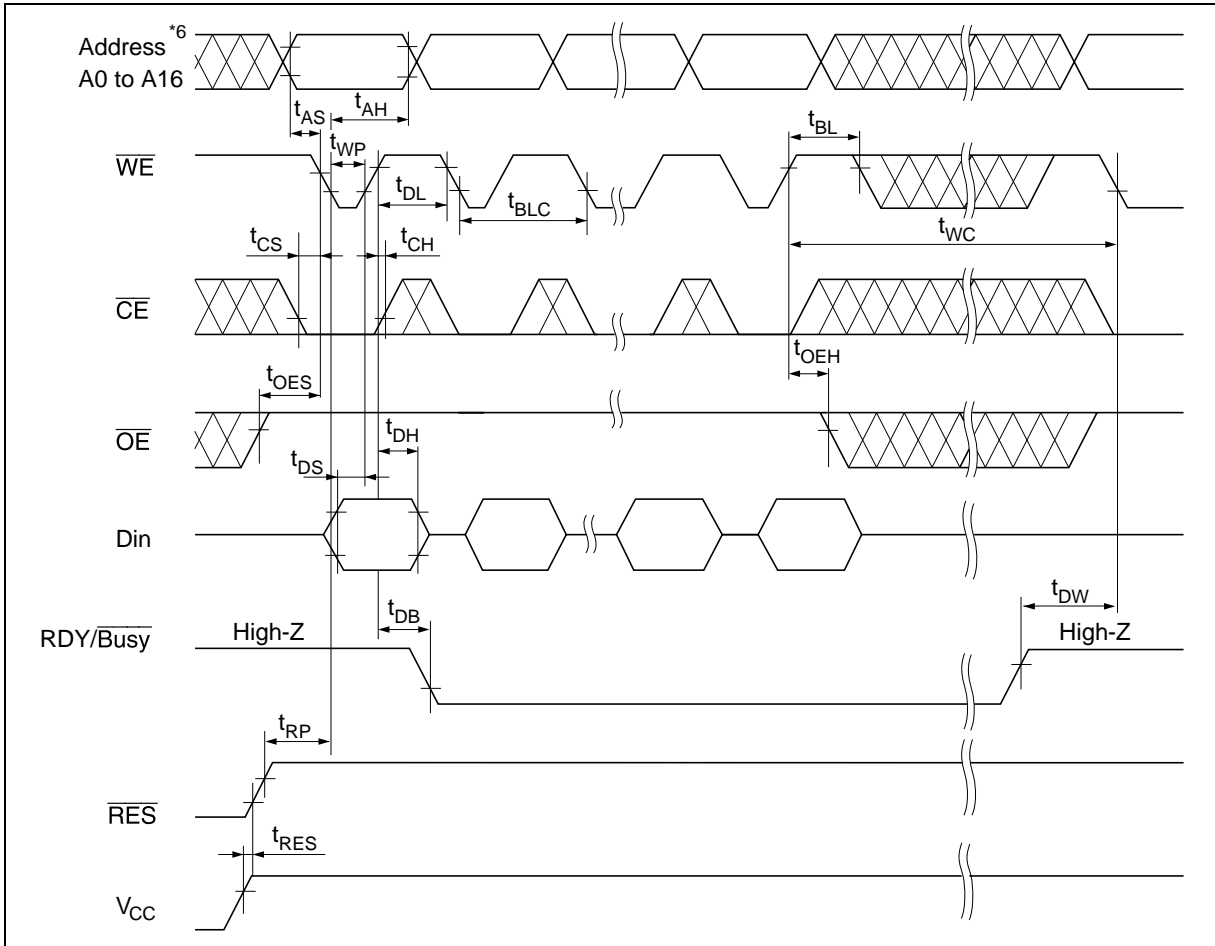

Page Write Timing Waveform (2) ( $\overline{\text{CE}}$  Controlled)

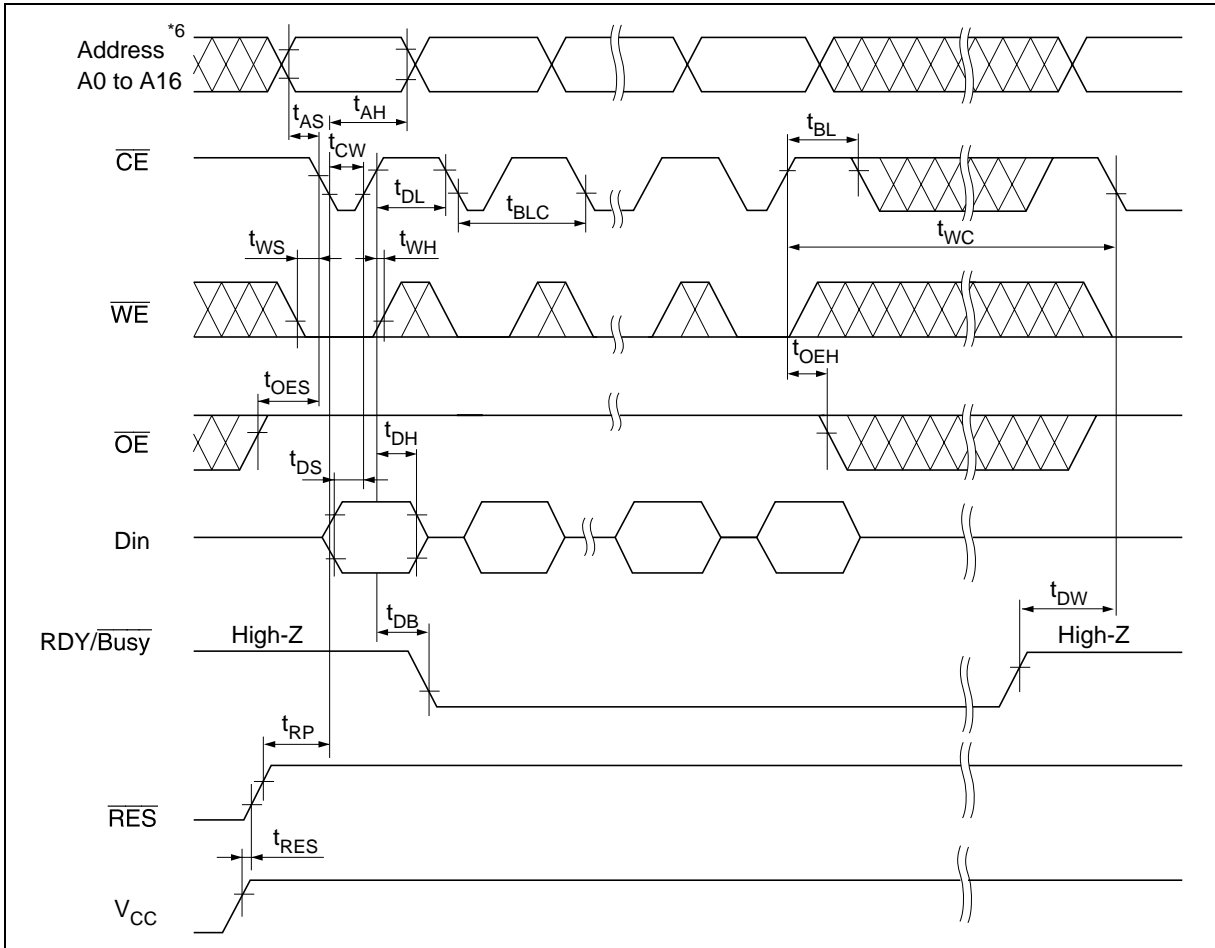



**Toggle bit**

This device provide another function to determine the internal programming cycle. If the EEPROM is set to read mode during the internal programming cycle, I/O6 will charge from “1” to “0” (togglng) for each read. When the internal programming cycle is finished, togglng of I/O6 will stop and the device can be accessible for next read or program.

- Notes: 1. I/O6 beginning state is “1”.
2. I/O6 ending state will vary.
3. See AC read characteristics.
4. Any location can be used, but the address must be fixed.

**Toggle bit Waveform**

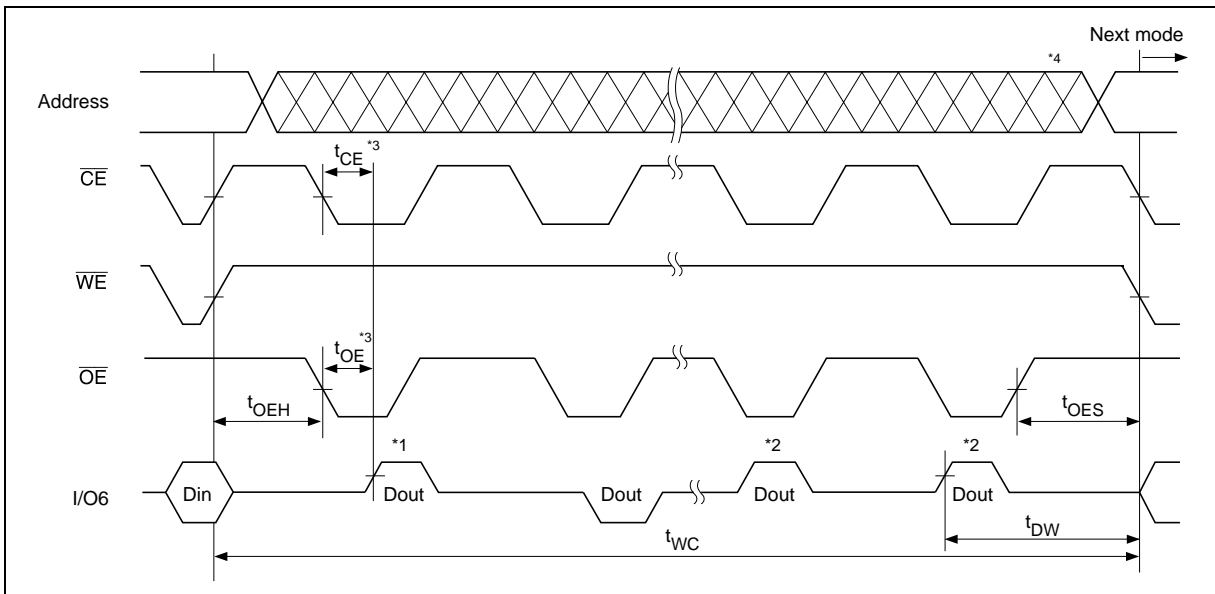

Software Data Protection Timing Waveform (1) (in protection mode)

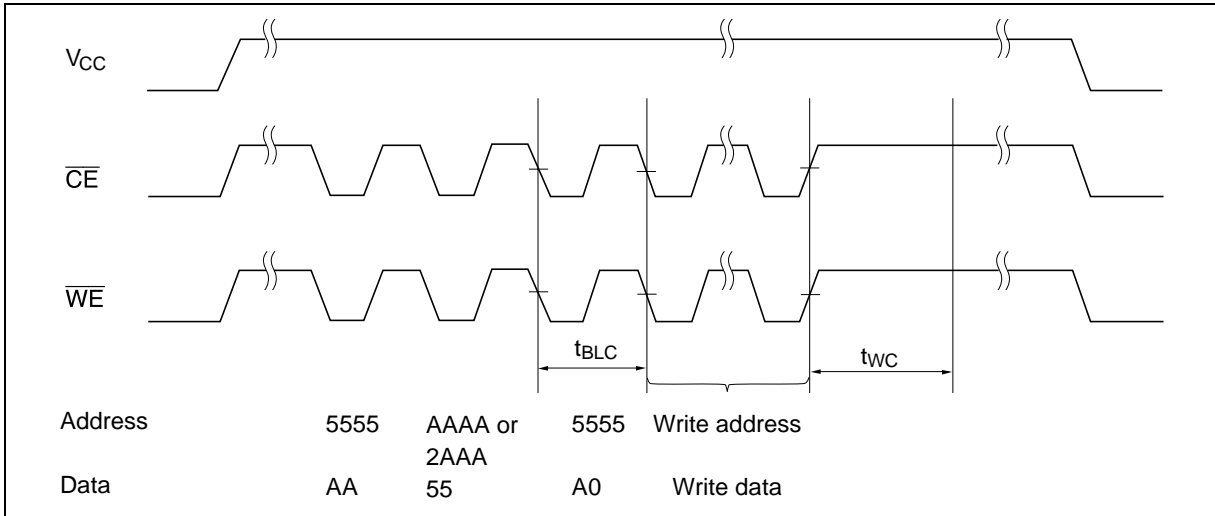

Software Data Protection Timing Waveform (2) (in non-protection mode)

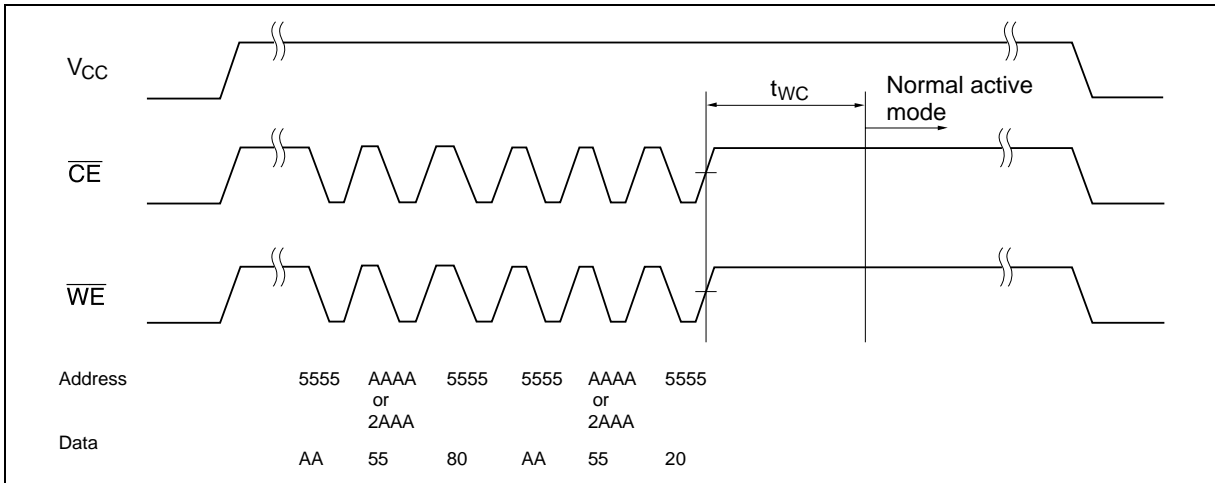

## Functional Description

### Automatic Page Write

Page-mode write feature allows 1 to 128 bytes of data to be written into the EEPROM in a single write cycle. Following the initial byte cycle, an additional 1 to 127 bytes can be written in the same manner. Each additional byte load cycle must be started within 30  $\mu$ s from the preceding falling edge of  $\overline{WE}$  or  $\overline{CE}$ . When  $\overline{CE}$  or  $\overline{WE}$  is kept high for 100  $\mu$ s after data input, the EEPROM enters write mode automatically and the input data are written into the EEPROM.

### $\overline{Data}$ Polling

Data polling allows the status of the EEPROM to be determined. If EEPROM is set to read mode during a write cycle, an inversion of the last byte of data to be loaded outputs from I/O7 to indicate that the EEPROM is performing a write operation.

### $\overline{RDY/Busy}$ Signal

$\overline{RDY/Busy}$  signal also allows status of the EEPROM to be determined. The  $\overline{RDY/Busy}$  signal has high impedance except in write cycle and is lowered to  $V_{OL}$  after the first write signal. At the end of write cycle, the  $\overline{RDY/Busy}$  signal changes state to high impedance.

### $\overline{RES}$ Signal

When  $\overline{RES}$  is low, the EEPROM cannot be read or programmed. Therefore, data can be protected by keeping  $\overline{RES}$  low when  $V_{CC}$  is switched.  $\overline{RES}$  should be high during read and programming because it doesn't provide a latch function.

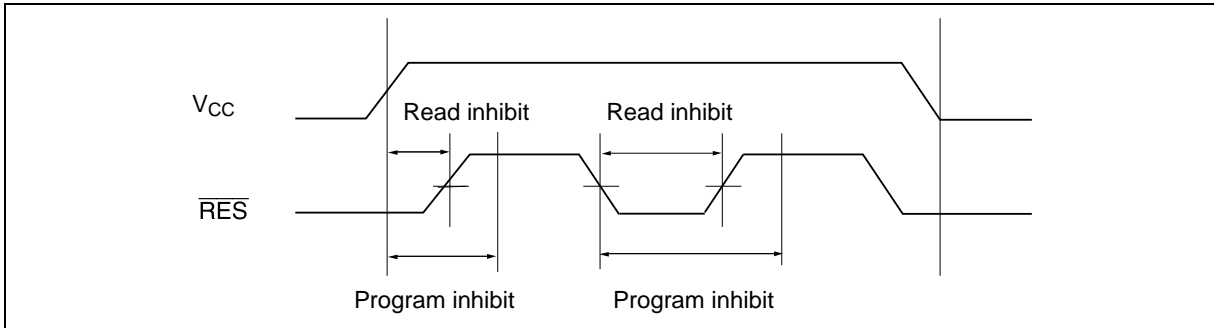

### $\overline{WE}$ , $\overline{CE}$ Pin Operation

During a write cycle, addresses are latched by the falling edge of  $\overline{WE}$  or  $\overline{CE}$ , and data is latched by the rising edge of  $\overline{WE}$  or  $\overline{CE}$ .

### Write/Erase Endurance and Data Retention Time

The endurance is  $10^4$  cycles in case of the page programming and  $10^3$  cycles in case of the byte programming (1% cumulative failure rate). The data retention time is more than 10 years when a device is page-programmed less than  $10^4$  cycles.

### Data Protection

To prevent this phenomenon, this device has a noise cancellation function that cuts noise if its width is 20 ns or less in program mode.

#### 1. Data Protection against Noise on Control Pins ( $\overline{\text{CE}}$ , $\overline{\text{OE}}$ , $\overline{\text{WE}}$ ) during Operation

During readout or standby, noise on the control pins may act as a trigger and turn the EEPROM to programming mode by mistake. Be careful not to allow noise of a width of more than 20 ns on the control pins.

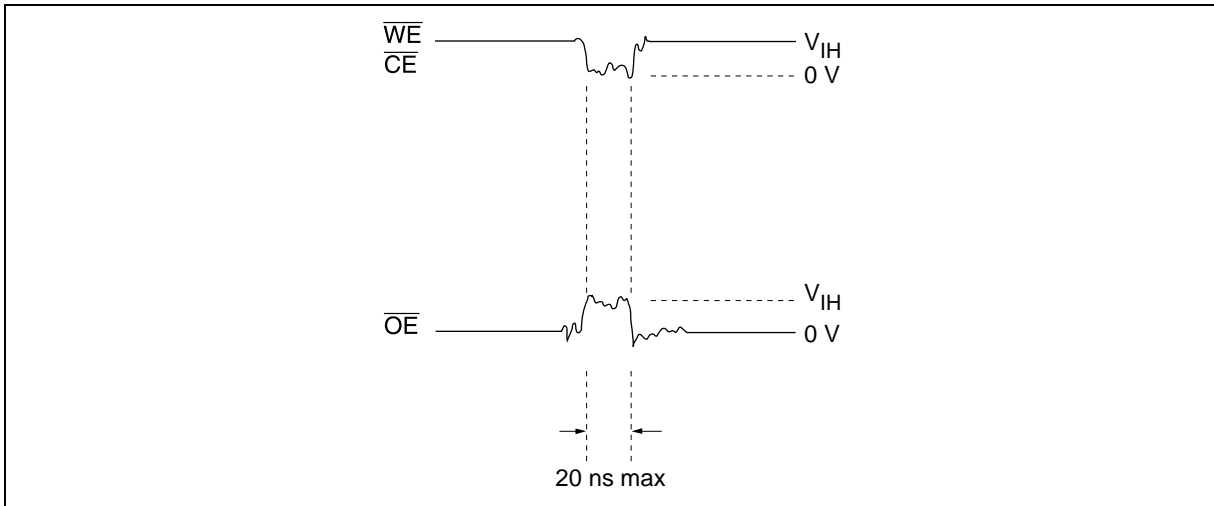

## HN58C1001 Series

### 2. Data Protection at $V_{CC}$ On/Off

When  $V_{CC}$  is turned on or off, noise on the control pins generated by external circuits (CPU, etc) may act as a trigger and turn the EEPROM to program mode by mistake. To prevent this unintentional programming, the EEPROM must be kept in an unprogrammable state while the CPU is in an unstable state.

Note: The EEPROM should be kept in unprogrammable state during  $V_{CC}$  on/off by using CPU RESET signal.

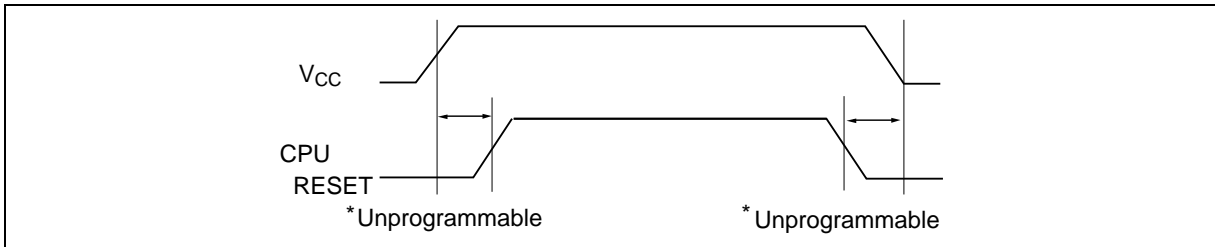

#### 2.1 Protection by $\overline{RES}$

The unprogrammable state can be realized by that the CPU's reset signal inputs directly to the EEPROM's  $\overline{RES}$  pin.  $\overline{RES}$  should be kept  $V_{SS}$  level during  $V_{CC}$  on/off.

The EEPROM brakes off programming operation when  $\overline{RES}$  becomes low, programming operation doesn't finish correctly in case that  $\overline{RES}$  falls low during programming operation.  $\overline{RES}$  should be kept high for 10 ms after the last data input.

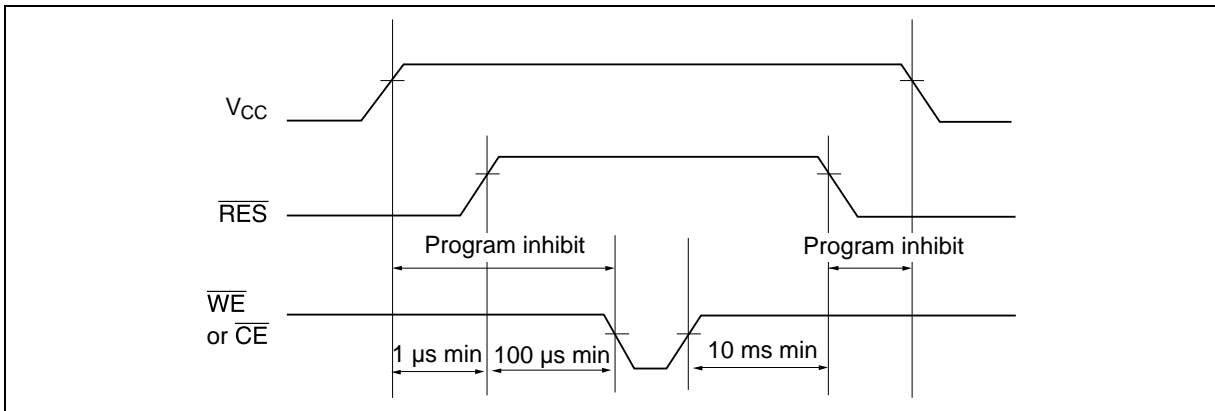

## HN58C1001 Series

---

### 3. Software data protection

To prevent unintentional programming, this device has the software data protection (SDP) mode. The SDP is enabled by inputting the following 3 bytes code and write data. SDP is not enabled if only the 3 bytes code is input. To program data in the SDP enable mode, 3 bytes code must be input before write data.

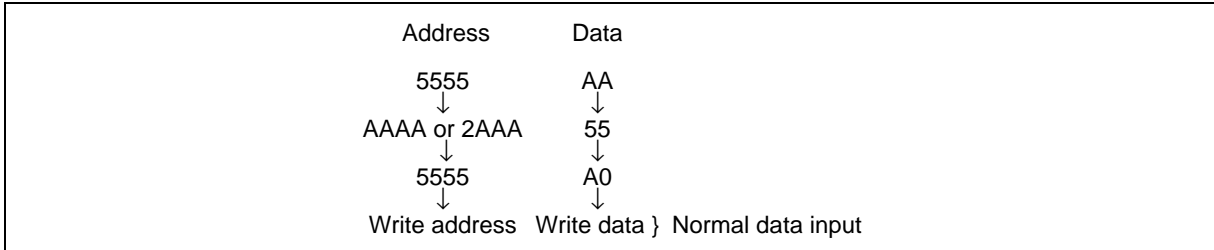

The SDP mode is disabled by inputting the following 6 bytes code. Note that, if data is input in the SDP disable cycle, data can not be written.

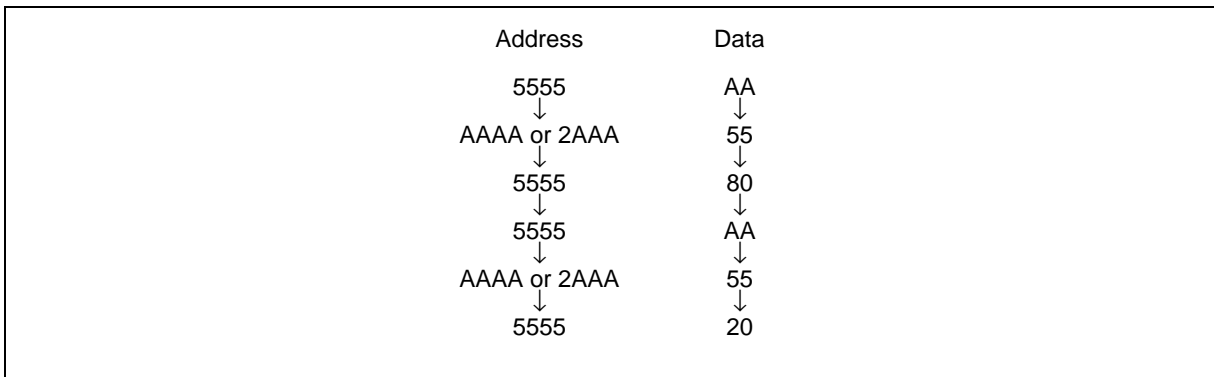

The software data protection is not enabled at the shipment.

Note: There are some differences between Renesas Technology's and other company's for enable/disable sequence of software data protection. If there are any questions, please contact with Renesas Technology's sales offices.

## HN58C1001 Series

### Package Dimensions

#### HN58C1001FP Series (FP-32D, FP-32DV)

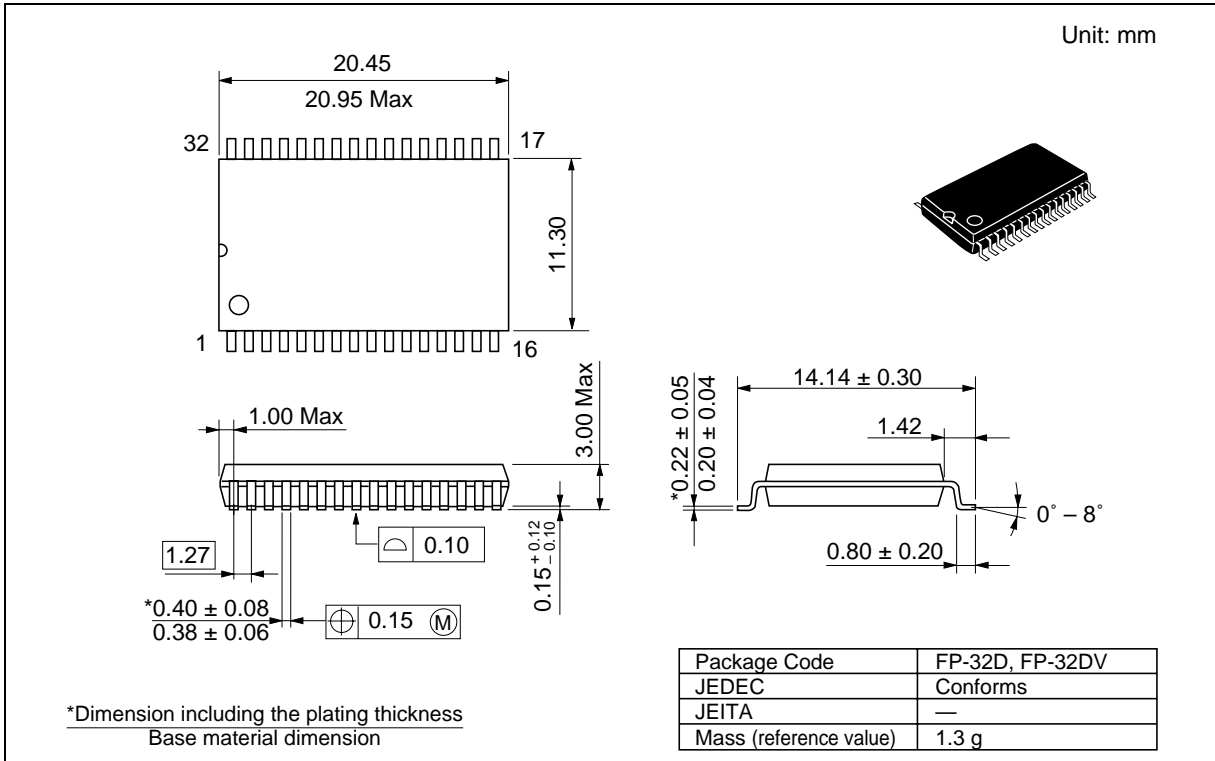

## HN58C1001 Series

### Package Dimensions (cont.)

#### HN58C1001T Series (TFP-32DA, TFP-32DAV)

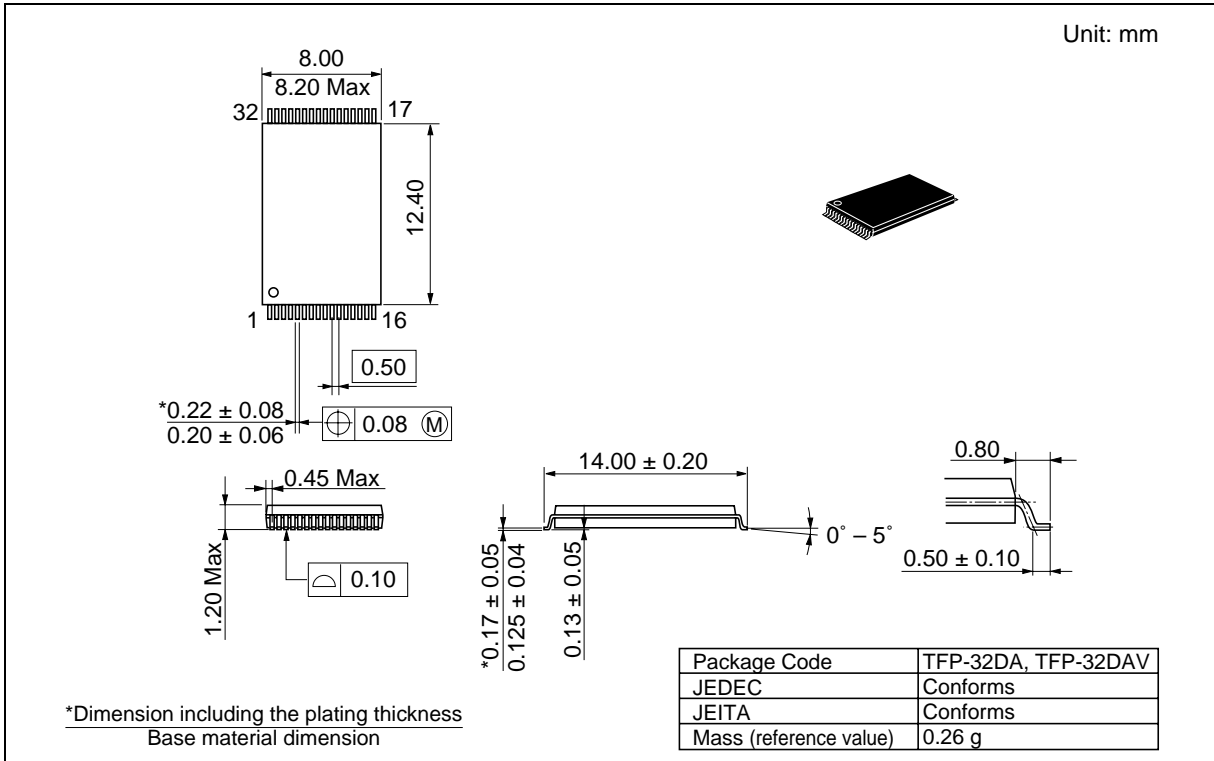

## Revision History

## HN58C1001 Series Data Sheet

Rev.	Date	Contents of Modification	
		Page	Description
0.0	Jul. 11. 1991	—	Initial issue
1.0	Jan. 10. 1992	—	Recommended DC Operating Conditions
		5	Addition of $V_H$ DC Characteristics $I_{CC3}$ max: 40 mA to 50 mA $I_{CC3}$ test: Cycle = 200 ns to Cycle = 150 ns $V_{IH}$ max: $V_{CC} + 1$ V to $V_{CC} + 0.3$ V $V_H$ min: $V_{CC} - 1.0$ V to $V_{CC} - 0.5$ V
		6	AC Characteristics Change of Test Conditions Reference level: 1.8 V to 2.0 V $t_{DL}$ min: 200 ns to 300 ns $t_{BLC}$ min: 0.35 $\mu$ s to 0.55 $\mu$ s $t_{WP}/t_{CW}$ min: 150 ns to 250 ns $t_{CS}/t_{CH}$ to $t_{WS}/t_{WH}$ ( $\overline{CE}$ Controlled)
		16	Functional Description Deletion of Write Protection (2) Data Protection 2: during programming because to during programming and read because unprogrammable, standby or readout state to unprogrammable state Deletion of protection of mistake by $\overline{CE} = V_{CC}$ or $\overline{OE} = \text{Low}$ or $\overline{WE} = V_{CC}$ level at $V_{CC}$ on/off Software data protection Address: AAAA to AAAA or 2AAA
		8	Change of Timing Waveforms
2.0	Jan. 21. 1993	—	Deletion of HN58C1001-12
		6	AC Characteristics $t_{DH}$ min: 0 ns to 10 ns
		—	Deletion of Mode Description
		—	Addition of Reset function
		—	Change of erase/write cycles in page mode: $10^5$ to $10^4$
		—	Change of erase/write cycles in byte mode: 104 to $10^3$
3.0	Apr. 23. 1993	14	Addition of Toggle Bit
4.0	Nov. 25. 1994	6	Capacitance Addition of note 1
		6	AC Characteristics Write cycle: Addition of note 2,3 Addition of $t_{DW}$ min: 150 ns
		11	Page write timing waveform Addition of note 1
5.0	May. 23. 1995	—	Deletion of HN58C1001R series (TFP-32DAR)

## Revision Record (cont.)

---

6.0	Apr. 8. 1997	—	Change of format
		6	AC Characteristics Addition of note.6
		8	Timing Waveforms Toggle bit Addition of note.3, 4
		16	Functional Description Addition of CPU Reset timing waveform Data protection 3: Addition of note

---

7.0	Oct. 31. 1997	8	Timing Waveforms Read Timing Waveforms: Correct error
-----	---------------	---	--

---

8.00	Nov. 27. 2003	—	Change format issued by Renesas Technology Corp.
		2	Ordering Information Deletion of HN58C1001P-15 Addition of HN58C1001FP-15E, HN58C1001T-15E
		20-21	Package Dimensions Deletion of DP-32 FP-32D to FP-32D, FP-32DV TFP-32DA to TFP-32DA, TFP-32DAV

---

## RENESAS Technology Corp. Sales Strategic Planning Div. Nippon Bldg., 2-6-2, Ohte-machi, Chiyoda-ku, Tokyo 100-0004, Japan

---

Keep safety first in your circuit designs!

1. Renesas Technology Corp. puts the maximum effort into making semiconductor products better and more reliable, but there is always the possibility that trouble may occur with them. Trouble with semiconductors may lead to personal injury, fire or property damage.  
Remember to give due consideration to safety when making your circuit designs, with appropriate measures such as (i) placement of substitutive, auxiliary circuits, (ii) use of nonflammable material or (iii) prevention against any malfunction or mishap.

Notes regarding these materials

1. These materials are intended as a reference to assist our customers in the selection of the Renesas Technology Corp. product best suited to the customer's application; they do not convey any license under any intellectual property rights, or any other rights, belonging to Renesas Technology Corp. or a third party.
  2. Renesas Technology Corp. assumes no responsibility for any damage, or infringement of any third-party's rights, originating in the use of any product data, diagrams, charts, programs, algorithms, or circuit application examples contained in these materials.
  3. All information contained in these materials, including product data, diagrams, charts, programs and algorithms represents information on products at the time of publication of these materials, and are subject to change by Renesas Technology Corp. without notice due to product improvements or other reasons. It is therefore recommended that customers contact Renesas Technology Corp. or an authorized Renesas Technology Corp. product distributor for the latest product information before purchasing a product listed herein.  
The information described here may contain technical inaccuracies or typographical errors.  
Renesas Technology Corp. assumes no responsibility for any damage, liability, or other loss rising from these inaccuracies or errors.  
Please also pay attention to information published by Renesas Technology Corp. by various means, including the Renesas Technology Corp. Semiconductor home page (<http://www.renesas.com>).
  4. When using any or all of the information contained in these materials, including product data, diagrams, charts, programs, and algorithms, please be sure to evaluate all information as a total system before making a final decision on the applicability of the information and products. Renesas Technology Corp. assumes no responsibility for any damage, liability or other loss resulting from the information contained herein.
  5. Renesas Technology Corp. semiconductors are not designed or manufactured for use in a device or system that is used under circumstances in which human life is potentially at stake. Please contact Renesas Technology Corp. or an authorized Renesas Technology Corp. product distributor when considering the use of a product contained herein for any specific purposes, such as apparatus or systems for transportation, vehicular, medical, aerospace, nuclear, or undersea repeater use.
  6. The prior written approval of Renesas Technology Corp. is necessary to reprint or reproduce in whole or in part these materials.
  7. If these products or technologies are subject to the Japanese export control restrictions, they must be exported under a license from the Japanese government and cannot be imported into a country other than the approved destination.  
Any diversion or reexport contrary to the export control laws and regulations of Japan and/or the country of destination is prohibited.
  8. Please contact Renesas Technology Corp. for further details on these materials or the products contained therein.
- 



### RENESAS SALES OFFICES

<http://www.renesas.com>

**Renesas Technology America, Inc.**  
450 Holger Way, San Jose, CA 95134-1368, U.S.A  
Tel: <1> (408) 382-7500 Fax: <1> (408) 382-7501

**Renesas Technology Europe Limited.**  
Dukes Meadow, Millboard Road, Bourne End, Buckinghamshire, SL8 5FH, United Kingdom  
Tel: <44> (1628) 585 100, Fax: <44> (1628) 585 900

**Renesas Technology Europe GmbH**  
Dornacher Str. 3, D-85622 Feldkirchen, Germany  
Tel: <49> (89) 380 70 0, Fax: <49> (89) 929 30 11

**Renesas Technology Hong Kong Ltd.**  
7/F., North Tower, World Finance Centre, Harbour City, Canton Road, Hong Kong  
Tel: <852> 2265-6688, Fax: <852> 2375-6836

**Renesas Technology Taiwan Co., Ltd.**  
FL 10, #99, Fu-Hsing N. Rd., Taipei, Taiwan  
Tel: <886> (2) 2715-2888, Fax: <886> (2) 2713-2999

**Renesas Technology (Shanghai) Co., Ltd.**  
26/F., Ruijin Building, No.205 Maoming Road (S), Shanghai 200020, China  
Tel: <86> (21) 6472-1001, Fax: <86> (21) 6415-2952

**Renesas Technology Singapore Pte. Ltd.**  
1, Harbour Front Avenue, #06-10, Keppel Bay Tower, Singapore 098632  
Tel: <65> 6213-0200, Fax: <65> 6278-8001



LittleDiode supplies new, hard to find or obsolete electronic components and semiconductors all over the world.

With over two million different components listed you are sure to find the part you need.

Feel free to visit us today at our online store:

[LittleDiode.com](http://LittleDiode.com)

Looking forward to providing you with the best possible service.