HN58C256A Series

HN58C257A Series

256k EEPROM (32-kword × 8-bit)
Ready/Busy and $\overline{\text{RES}}$ function (HN58C257A)

REJ03C0148-0500Z
(Previous ADE-203-410D (Z) Rev. 4.0)
Rev. 5.00
Nov. 17. 2003

Description

Renesas Technology's HN58C256A and HN58C257A are electrically erasable and programmable ROMs organized as 32768-word × 8-bit. They have realized high speed low power consumption and high reliability by employing advanced MNOS memory technology and CMOS process and circuitry technology. They also have a 64-byte page programming function to make their write operations faster.

Features

- Single 5 V supply: 5 V ±10%
- Access time: 85 ns/100 ns (max)
- Power dissipation
 - Active: 20 mW/MHz, (typ)
 - Standby: 110 μW (max)
- On-chip latches: address, data, $\overline{\text{CE}}$, $\overline{\text{OE}}$, $\overline{\text{WE}}$
- Automatic byte write: 10 ms max
- Automatic page write (64 bytes): 10 ms max
- Ready/Busy (only the HN58C257A series)
- $\overline{\text{Data}}$ polling and Toggle bit
- Data protection circuit on power on/off
- Conforms to JEDEC byte-wide standard
- Reliable CMOS with MNOS cell technology
- 10⁵ erase/write cycles (in page mode)
- 10 years data retention
- Software data protection
- Write protection by $\overline{\text{RES}}$ pin (only the HN58C257A series)
- Industrial versions (Temperatur range: -20 to 85°C and -40 to 85°C) are also available.
- There are also lead free products.

Ordering Information

Type No.	Access time	Package
HN58C256AP-85	85 ns	600 mil 28-pin plastic DIP (DP-28)
HN58C256AP-10	100 ns	
HN58C256AFP-85	85 ns	400 mil 28-pin plastic SOP (FP-28D)
HN58C256AFP-10	100 ns	
HN58C256AT-85	85 ns	28-pin plastic TSOP (TFP-28DB)
HN58C256AT-10	100 ns	
HN58C257AT-85	85 ns	32-pin plastic TSOP (TFP-32DA)
HN58C257AT-10	100 ns	
HN58C256AFP-85E	85 ns	400 mil 28-pin plastic SOP (FP-28DV) Lead free
HN58C256AFP-10E	100 ns	
HN58C256AT-85E	85 ns	28-pin plastic TSOP (TFP-28DBV) Lead free
HN58C256AT-10E	100 ns	
HN58C257AT-85E	85 ns	32-pin plastic TSOP (TFP-32DAV) Lead free
HN58C257AT-10E	100 ns	

Pin Arrangement

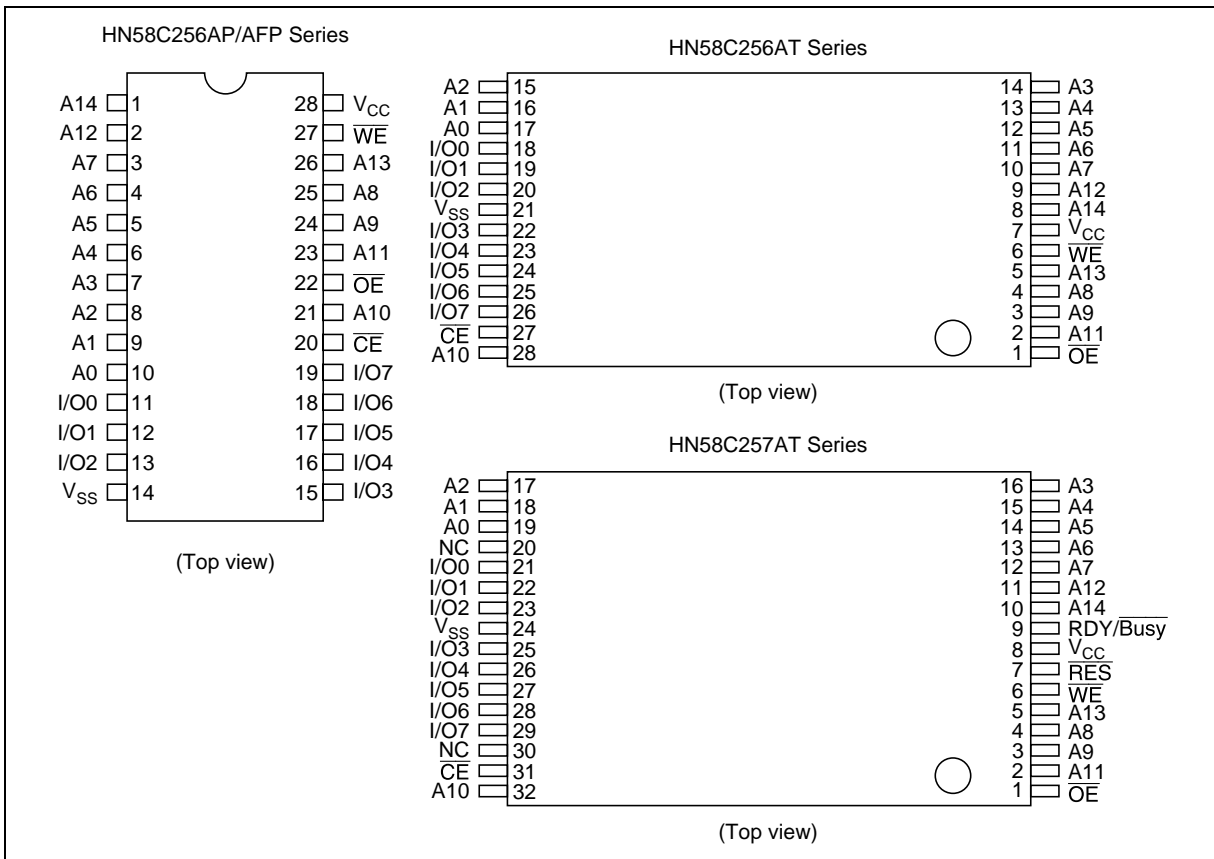

Pin Description

Pin name	Function
A0 to A14	Address input
I/O0 to I/O7	Data input/output
\overline{OE}	Output enable
\overline{CE}	Chip enable
\overline{WE}	Write enable
V_{CC}	Power supply
V_{SS}	Ground
$\overline{RDY/Busy}^{*1}$	Ready busy
\overline{RES}^{*1}	Reset
NC	No connection

Note: 1. This function is supported by only the HN58C257A series.

Block Diagram

Note: 1. This function is supported by only the HN58C257A series.

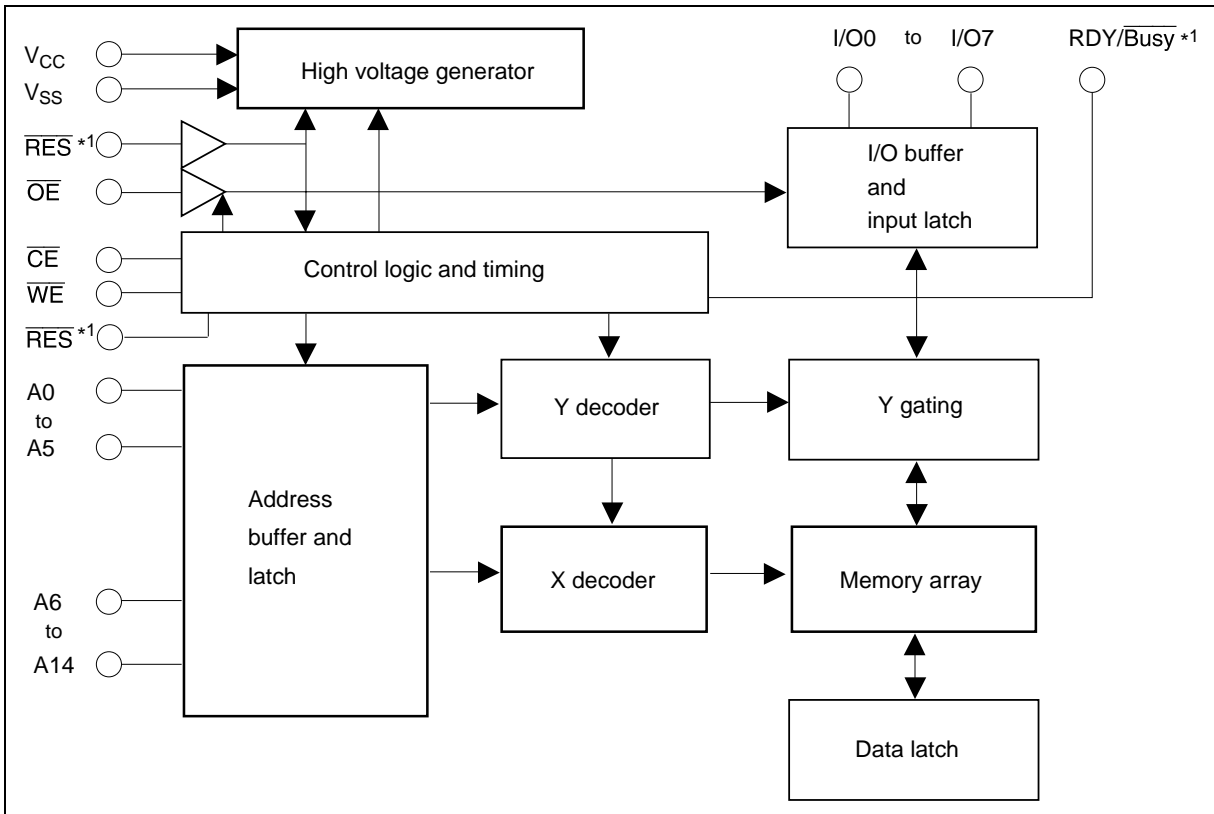

Operation Table

Operation	\overline{CE}	\overline{OE}	\overline{WE}	\overline{RES}^{*3}	$\overline{RDY/Busy}^{*3}$	I/O
Read	V_{IL}	V_{IL}	V_{IH}	V_H^{*1}	High-Z	Dout
Standby	V_{IH}	\times^{*2}	\times	\times	High-Z	High-Z
Write	V_{IL}	V_{IH}	V_{IL}	V_H	High-Z to V_{OL}	Din
Deselect	V_{IL}	V_{IH}	V_{IH}	V_H	High-Z	High-Z
Write inhibit	\times	\times	V_{IH}	\times	—	—
	\times	V_{IL}	\times	\times	—	—
Data polling	V_{IL}	V_{IL}	V_{IH}	V_H	V_{OL}	Dout (I/O7)
Program reset	\times	\times	\times	V_{IL}	High-Z	High-Z

- Notes: 1. Refer to the recommended DC operating condition.
 2. \times : Don't care
 3. This function is supported by only the HN58C257A series.

Absolute Maximum Ratings

Parameter	Symbol	Value	Unit
Power supply voltage relative to V_{SS}	V_{CC}	-0.6 to +7.0	V
Input voltage relative to V_{SS}	V_{in}	-0.5 ^{*1} to +7.0 ^{*3}	V
Operating temperature range ^{*2}	T_{opr}	0 to +70	°C
Storage temperature range	T_{stg}	-55 to +125	°C

- Notes: 1. $V_{in\ min} = -3.0\ V$ for pulse width $\leq 50\ ns$
 2. Including electrical characteristics and data retention
 3. Should not exceed $V_{CC} + 1\ V$.

Recommended DC Operating Conditions

Parameter	Symbol	Min	Typ	Max	Unit
Supply voltage	V_{CC}	4.5	5.0	5.5	V
	V_{SS}	0	0	0	V
Input voltage	V_{IL}	-0.3 ^{*1}	—	0.8	V
	V_{IH}	2.2	—	$V_{CC} + 0.3^{*2}$	V
	V_H^{*3}	$V_{CC} - 0.5$	—	$V_{CC} + 1.0$	V
Operating temperature	T_{opr}	0	—	+70	°C

- Notes: 1. $V_{IL\ min}: -1.0\ V$ for pulse width $\leq 50\ ns$.
 2. $V_{IH\ max}: V_{CC} + 1.0\ V$ for pulse width $\leq 50\ ns$.
 3. This function is supported by only the HN58C257A series.

HN58C256A Series, HN58C257A Series

DC Characteristics (Ta = 0 to +70°C, V_{CC} = 5.0 V ±10%)

Parameter	Symbol	Min	Typ	Max	Unit	Test conditions
Input leakage current	I _{LI}	—	—	2* ¹	μA	V _{CC} = 5.5 V, Vin = 5.5 V
Output leakage current	I _{LO}	—	—	2	μA	V _{CC} = 5.5 V, Vout = 5.5/0.4 V
Standby V _{CC} current	I _{CC1}	—	—	20	μA	$\overline{CE} = V_{CC}$
	I _{CC2}	—	—	1	mA	$\overline{CE} = V_{IH}$
Operating V _{CC} current	I _{CC3}	—	—	12	mA	Iout = 0 mA, Duty = 100%, Cycle = 1 μs, V _{CC} = 5.5 V
		—	—	30	mA	Iout = 0 mA, Duty = 100%, Cycle = 85 ns, V _{CC} = 5.5 V
Output low voltage	V _{OL}	—	—	0.4	V	I _{OL} = 2.1 mA
Output high voltage	V _{OH}	2.4	—	—	V	I _{OH} = -400 μA

Note: 1. I_{LI} on \overline{RES} = 100 μA max (only the HN58C257A series)

Capacitance (Ta = +25°C, f = 1 MHz)

Parameter	Symbol	Min	Typ	Max	Unit	Test conditions
Input capacitance* ¹	Cin	—	—	6	pF	Vin = 0 V
Output capacitance* ¹	Cout	—	—	12	pF	Vout = 0 V

Note: 1. This parameter is periodically sampled and not 100% tested.

HN58C256A Series, HN58C257A Series

AC Characteristics (Ta = 0 to +70°C, V_{CC} = 5 V±10%)

Test Conditions

- Input pulse levels: 0.4 V to 3.0 V, 0 V to V_{CC} ($\overline{\text{RES}}$ pin*²)
- Input rise and fall time: ≤ 5 ns
- Input timing reference levels: 0.8, 2.0 V
- Output load: 1TTL Gate +100 pF
- Output reference levels: 1.5 V, 1.5 V

Read Cycle

Parameter	Symbol	HN58C256A/HN58C257A				Unit	Test conditions
		-85		-10			
		Min	Max	Min	Max		
Address to output delay	t _{ACC}	—	85	—	100	ns	$\overline{\text{CE}} = \overline{\text{OE}} = V_{\text{IL}}$, $\overline{\text{WE}} = V_{\text{IH}}$
$\overline{\text{CE}}$ to output delay	t _{CE}	—	85	—	100	ns	$\overline{\text{OE}} = V_{\text{IL}}$, $\overline{\text{WE}} = V_{\text{IH}}$
$\overline{\text{OE}}$ to output delay	t _{OE}	10	40	10	50	ns	$\overline{\text{CE}} = V_{\text{IL}}$, $\overline{\text{WE}} = V_{\text{IH}}$
Address to output hold	t _{OH}	0	—	0	—	ns	$\overline{\text{CE}} = \overline{\text{OE}} = V_{\text{IL}}$, $\overline{\text{WE}} = V_{\text{IH}}$
$\overline{\text{OE}}$ ($\overline{\text{CE}}$) high to output float* ¹	t _{DF}	0	40	0	40	ns	$\overline{\text{CE}} = V_{\text{IL}}$, $\overline{\text{WE}} = V_{\text{IH}}$
$\overline{\text{RES}}$ low to output float* ^{1,2}	t _{DFR}	0	350	0	350	ns	$\overline{\text{CE}} = \overline{\text{OE}} = V_{\text{IL}}$, $\overline{\text{WE}} = V_{\text{IH}}$
$\overline{\text{RES}}$ to output delay* ²	t _{RR}	0	450	0	450	ns	$\overline{\text{CE}} = \overline{\text{OE}} = V_{\text{IL}}$, $\overline{\text{WE}} = V_{\text{IH}}$

Write Cycle

Parameter	Symbol	Min* ³	Typ	Max	Unit	Test conditions
Address setup time	t_{AS}	0	—	—	ns	
Address hold time	t_{AH}	50	—	—	ns	
\overline{CE} to write setup time (\overline{WE} controlled)	t_{CS}	0	—	—	ns	
\overline{CE} hold time (\overline{WE} controlled)	t_{CH}	0	—	—	ns	
\overline{WE} to write setup time (\overline{CE} controlled)	t_{WS}	0	—	—	ns	
\overline{WE} hold time (\overline{CE} controlled)	t_{WH}	0	—	—	ns	
\overline{OE} to write setup time	t_{OES}	0	—	—	ns	
\overline{OE} hold time	t_{OEH}	0	—	—	ns	
Data setup time	t_{DS}	50	—	—	ns	
Data hold time	t_{DH}	0	—	—	ns	
\overline{WE} pulse width (\overline{WE} controlled)	t_{WIP}	100	—	—	ns	
\overline{CE} pulse width (\overline{CE} controlled)	t_{CW}	100	—	—	ns	
Data latch time	t_{DL}	50	—	—	ns	
Byte load cycle	t_{BLC}	0.2	—	30	μ s	
Byte load window	t_{BL}	100	—	—	μ s	
Write cycle time	t_{WC}	—	—	10* ⁴	ms	
Time to device busy	t_{DB}	120	—	—	ns	
Write start time	t_{DW}	0* ⁵	—	—	ns	
Reset protect time* ²	t_{RP}	100	—	—	μ s	
Reset high time* ^{2,6}	t_{RES}	1	—	—	μ s	

Notes: 1. t_{DF} and t_{DFR} are defined as the time at which the outputs achieve the open circuit conditions and are no longer driven.

2. This function is supported by only the HN58C257A series.
3. Use this device in longer cycle than this value.
4. t_{WC} must be longer than this value unless polling techniques or $\overline{RDY}/\overline{Busy}$ (only the HN58C257A series) are used. This device automatically completes the internal write operation within this value.
5. Next read or write operation can be initiated after t_{DW} if polling techniques or $\overline{RDY}/\overline{Busy}$ (only the HN58C257A series) are used.
6. This parameter is sampled and not 100% tested.
7. A6 through A14 are page address and these addresses are latched at the first falling edge of \overline{WE} .
8. A6 through A14 are page address and these addresses are latched at the first falling edge of \overline{CE} .
9. See AC read characteristics.

Timing Waveforms

Read Timing Waveform

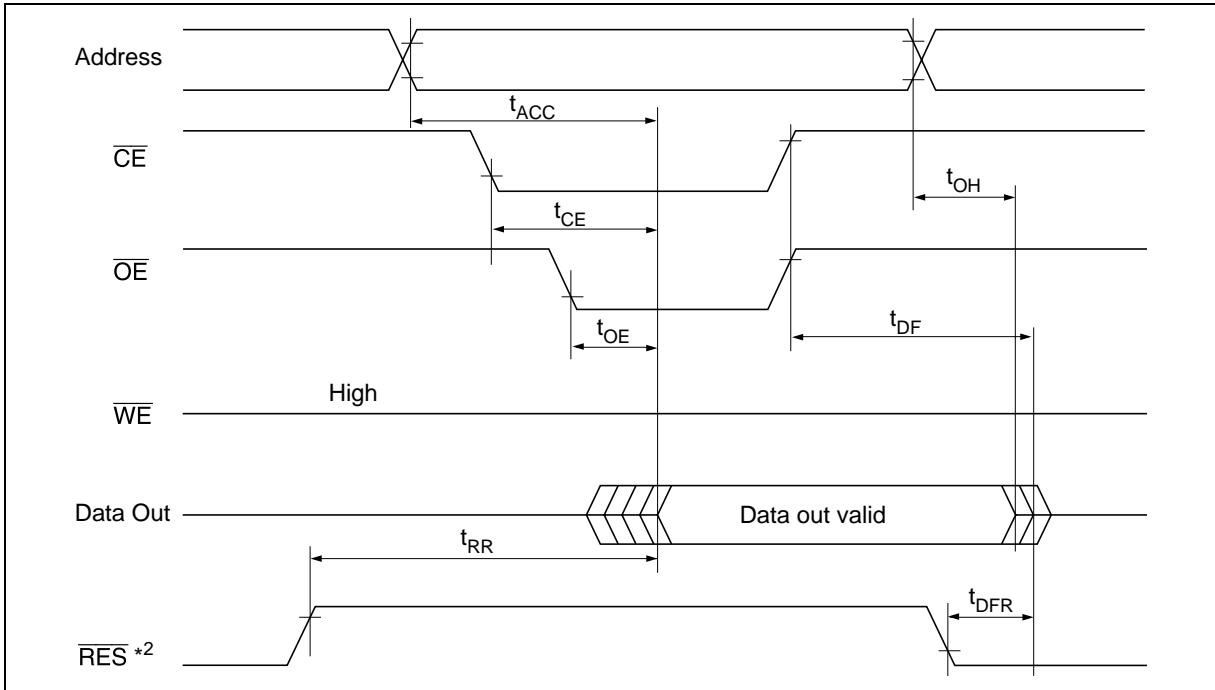

Byte Write Timing Waveform (1) (\overline{WE} Controlled)

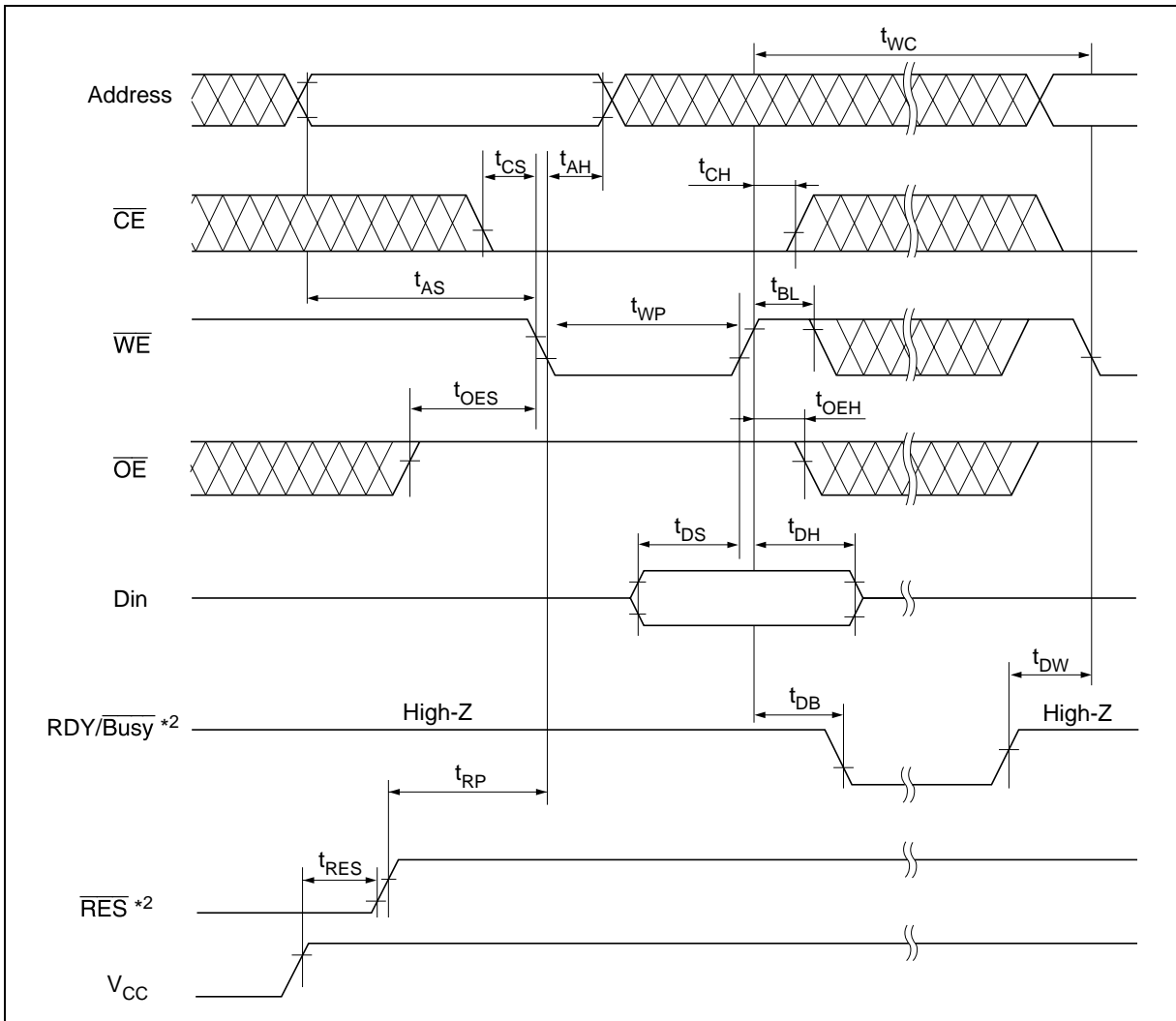

Byte Write Timing Waveform (2) ($\overline{\text{CE}}$ Controlled)

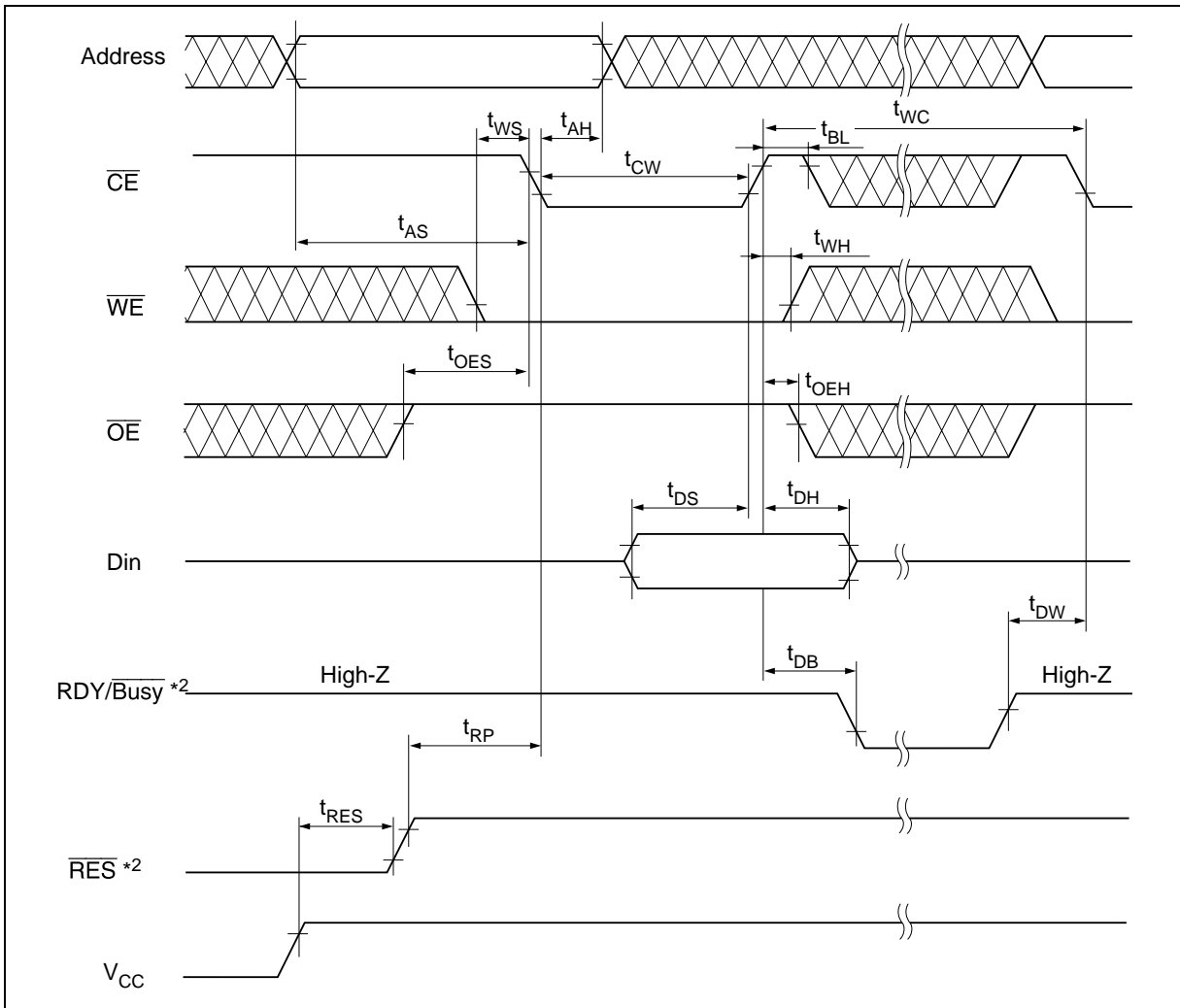

Page Write Timing Waveform (1) ($\overline{\text{WE}}$ Controlled)

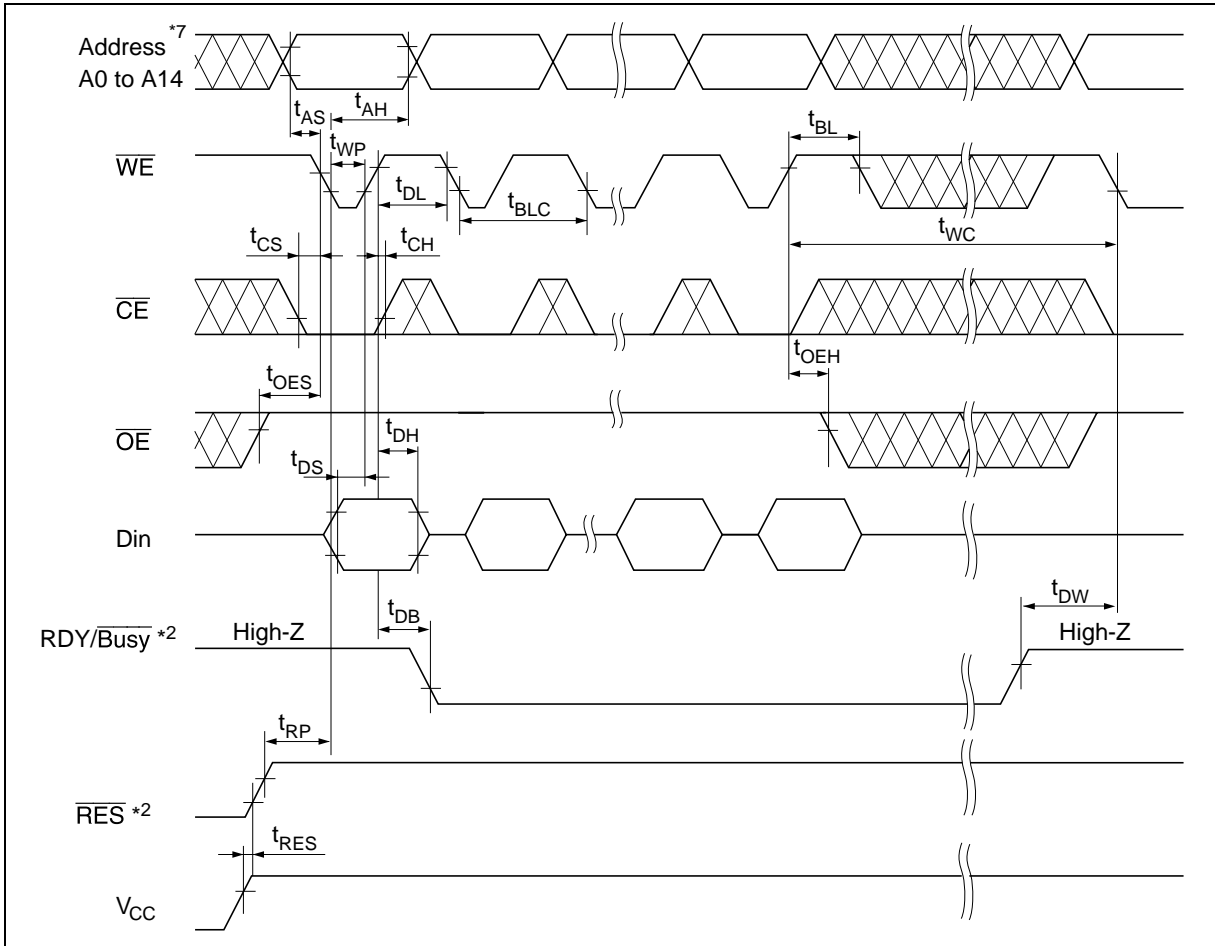

Page Write Timing Waveform (2) (\overline{CE} Controlled)

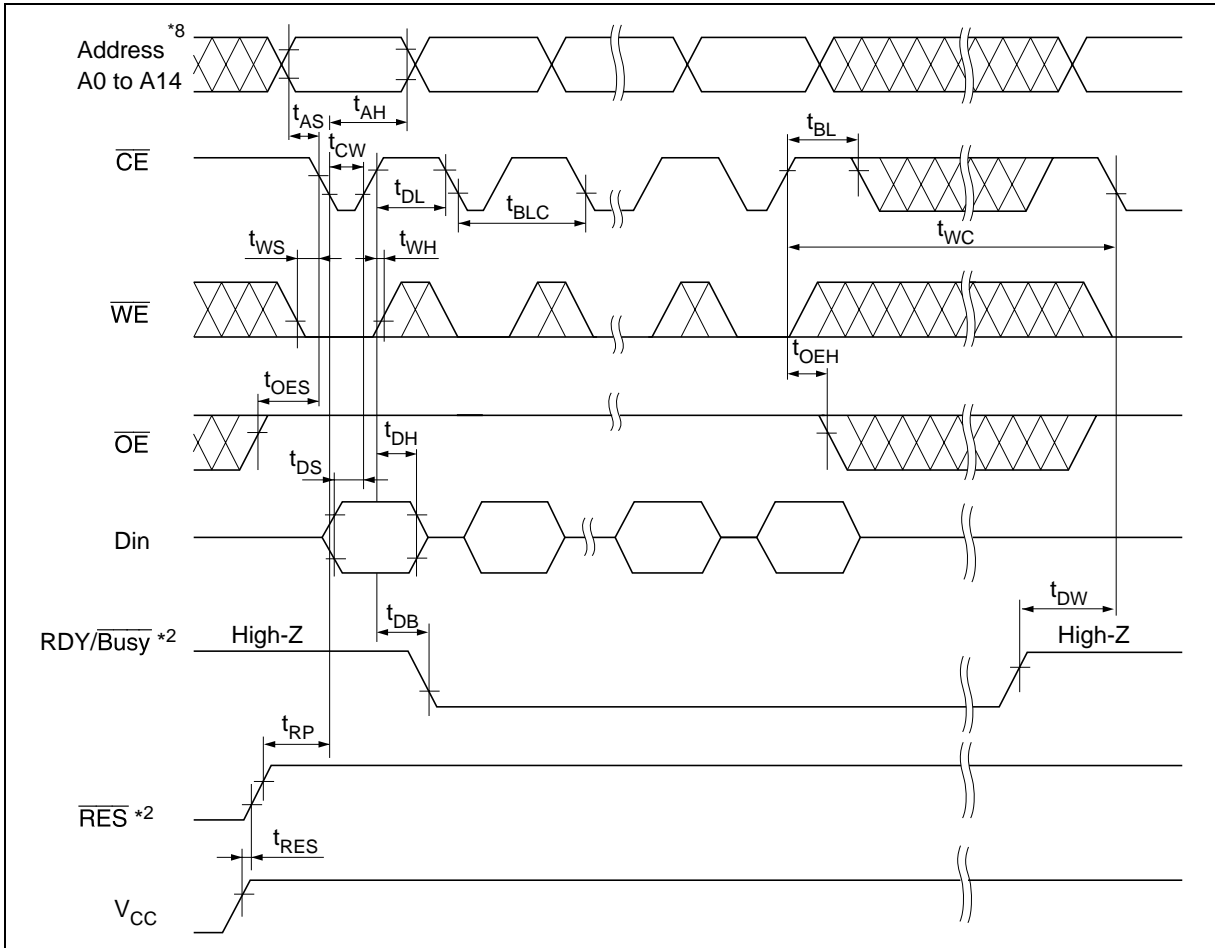

Data Polling Timing Waveform

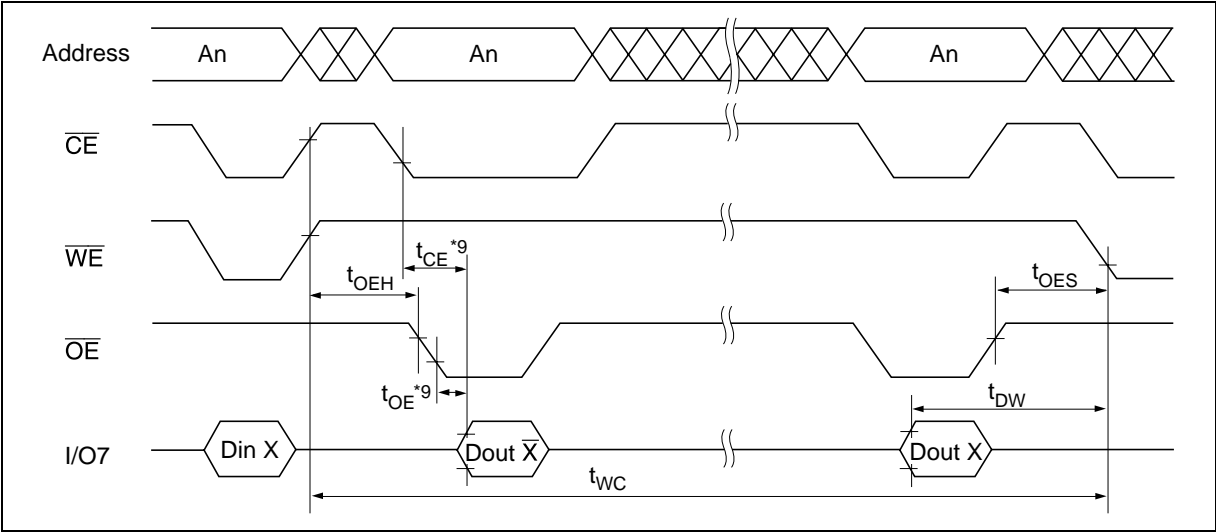

Toggle bit

This device provide another function to determine the internal programming cycle. If the EEPROM is set to read mode during the internal programming cycle, I/O6 will charge from “1” to “0” (toggling) for each read. When the internal programming cycle is finished, toggling of I/O6 will stop and the device can be accessible for next read or program.

Toggle bit Waveform

- Notes: 1. I/O6 beginning state is "1".
 2. I/O6 ending state will vary.
 3. See AC read characteristics.
 4. Any address location can be used, but the address must be fixed.

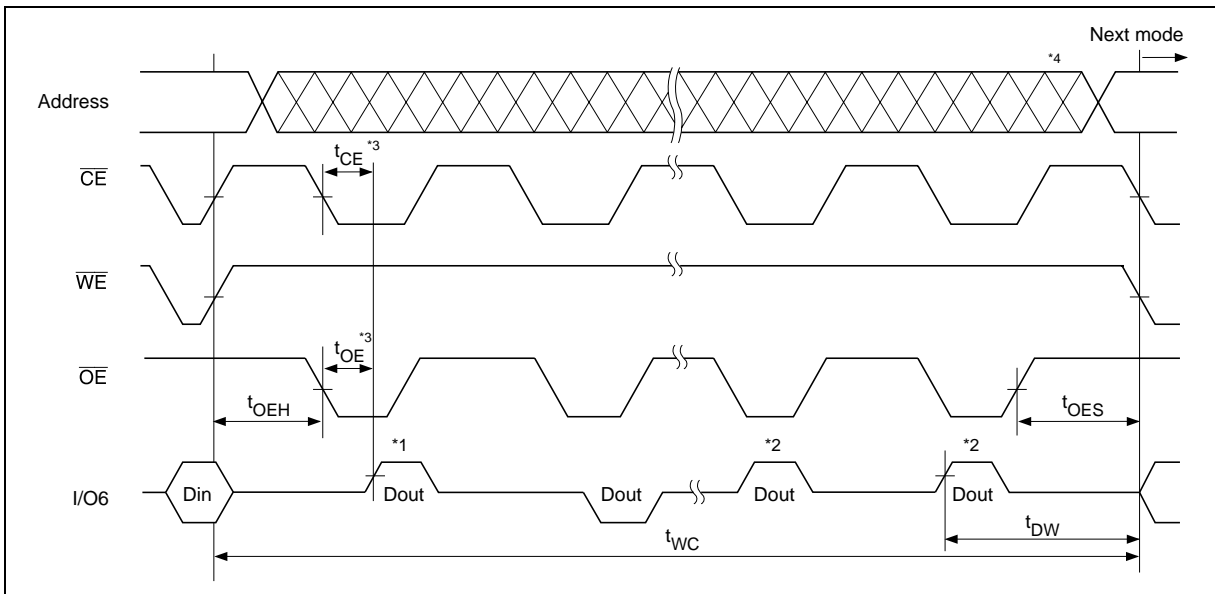

Software Data Protection Timing Waveform (1) (in protection mode)

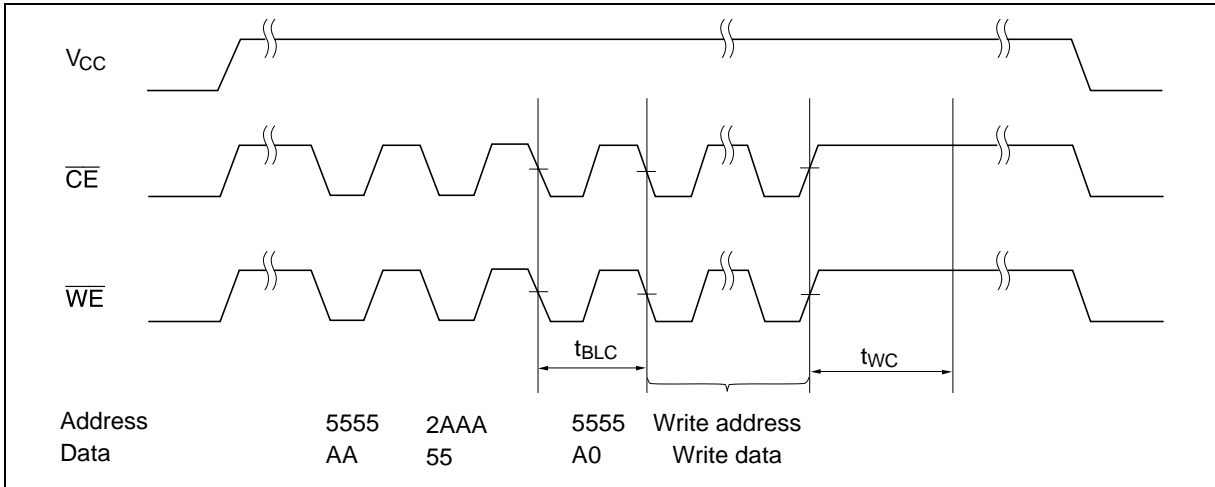

Software Data Protection Timing Waveform (2) (in non-protection mode)

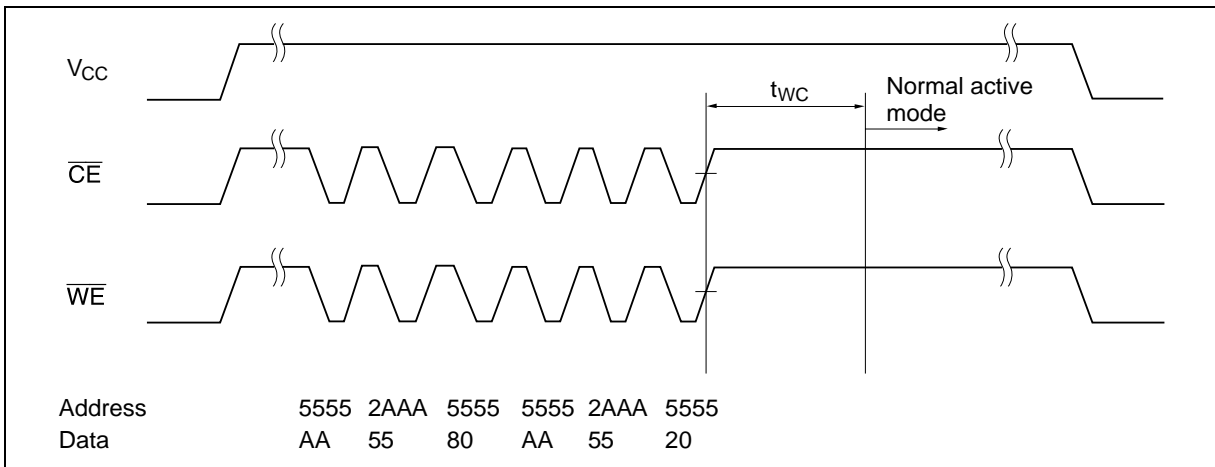

Functional Description

Automatic Page Write

Page-mode write feature allows 1 to 64 bytes of data to be written into the EEPROM in a single write cycle. Following the initial byte cycle, an additional 1 to 63 bytes can be written in the same manner. Each additional byte load cycle must be started within 30 μ s from the preceding falling edge of \overline{WE} or \overline{CE} . When \overline{CE} or \overline{WE} is high for 100 μ s after data input, the EEPROM enters write mode automatically and the input data are written into the EEPROM.

\overline{RDY} Polling

\overline{RDY} indicates the status that the EEPROM is in a write cycle or not. If EEPROM is set to read mode during a write cycle, an inversion of the last byte of data outputs from I/O7 to indicate that the EEPROM is performing a write operation.

$\overline{RDY/Busy}$ Signal (only the HN58C257A series)

$\overline{RDY/Busy}$ signal also allows status of the EEPROM to be determined. The $\overline{RDY/Busy}$ signal has high impedance except in write cycle and is lowered to V_{OL} after the first write signal. At the end of a write cycle, the $\overline{RDY/Busy}$ signal changes state to high impedance.

\overline{RES} Signal (only the HN58C257A series)

When \overline{RES} is low, the EEPROM cannot be read or programmed. Therefore, data can be protected by keeping \overline{RES} low when V_{CC} is switched. \overline{RES} should be high during read and programming because it doesn't provide a latch function.

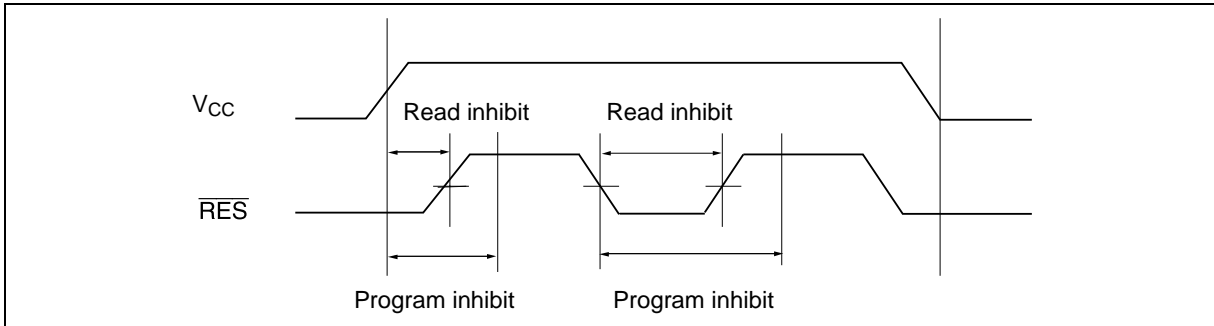

\overline{WE} , \overline{CE} Pin Operation

During a write cycle, addresses are latched by the falling edge of \overline{WE} or \overline{CE} , and data is latched by the rising edge of \overline{WE} or \overline{CE} .

Write/Erase Endurance and Data Retention Time

The endurance is 10^5 cycles in case of the page programming and 10^4 cycles in case of the byte programming (1% cumulative failure rate). The data retention time is more than 10 years when a device is page-programmed less than 10^4 cycles.

Data Protection

To prevent this phenomenon, this device has a noise cancelation function that cuts noise if its width is 20 ns or less.

1. Data Protection against Noise on Control Pins (\overline{CE} , \overline{OE} , \overline{WE}) during Operation

During readout or standby, noise on the control pins may act as a trigger and turn the EEPROM to programming mode by mistake. Be careful not to allow noise of a width of more than 20 ns on the control pins.

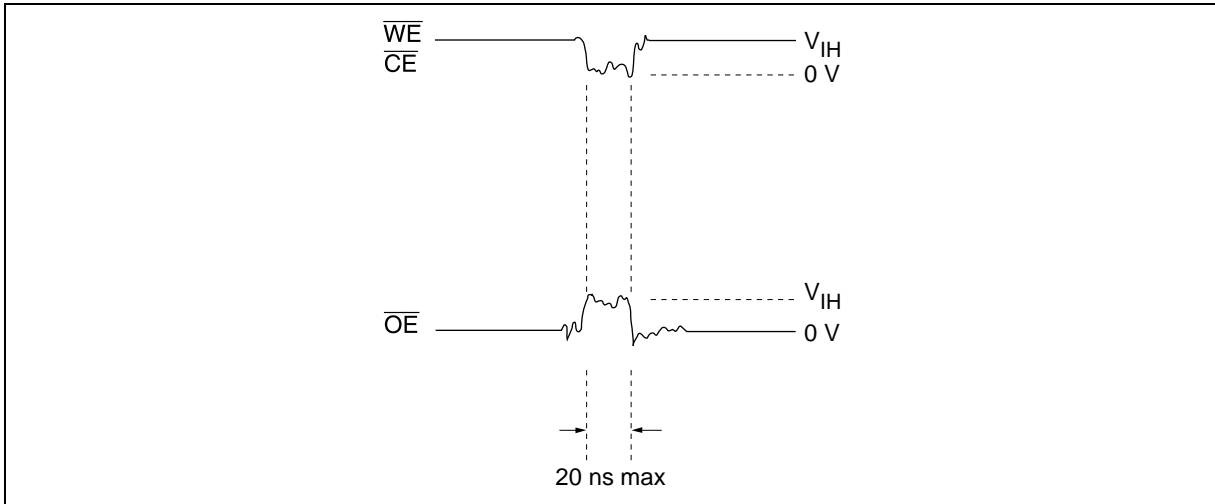

HN58C256A Series, HN58C257A Series

2. Data Protection at V_{CC} On/Off

When V_{CC} is turned on or off, noise on the control pins generated by external circuits (CPU, etc) may act as a trigger and turn the EEPROM to program mode by mistake. To prevent this unintentional programming, the EEPROM must be kept in an unprogrammable state while the CPU is in an unstable state.

Note: The EEPROM should be kept in unprogrammable state during V_{CC} on/off by using CPU RESET signal.

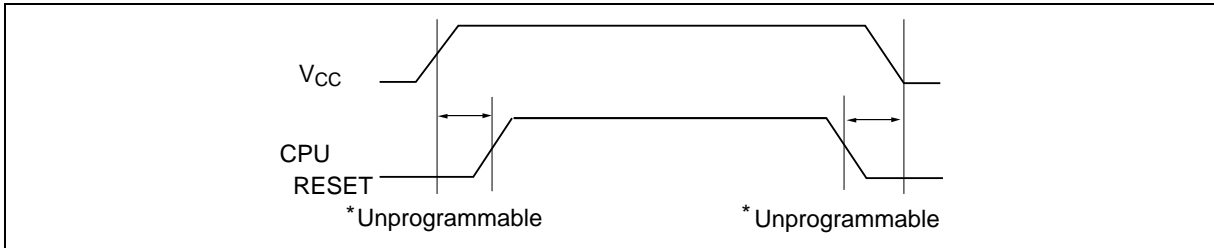

2.1 Protection by \overline{CE} , \overline{OE} , \overline{WE}

To realize the unprogrammable state, the input level of control pins must be held as shown in the table below.

\overline{CE}	V_{CC}	×	×
\overline{OE}	×	V_{SS}	×
\overline{WE}	×	×	V_{CC}

×: Don't care.

V_{CC} : Pull-up to V_{CC} level.

V_{SS} : Pull-down to V_{SS} level.

2.2 Protection by \overline{RES} (only the HN58C257A series)

The unprogrammable state can be realized by that the CPU's reset signal inputs directly to the EEPROM's \overline{RES} pin. \overline{RES} should be kept V_{SS} level during V_{CC} on/off.

The EEPROM breaks off programming operation when \overline{RES} becomes low, programming operation doesn't finish correctly in case that \overline{RES} falls low during programming operation. \overline{RES} should be kept high for 10 ms after the last data input.

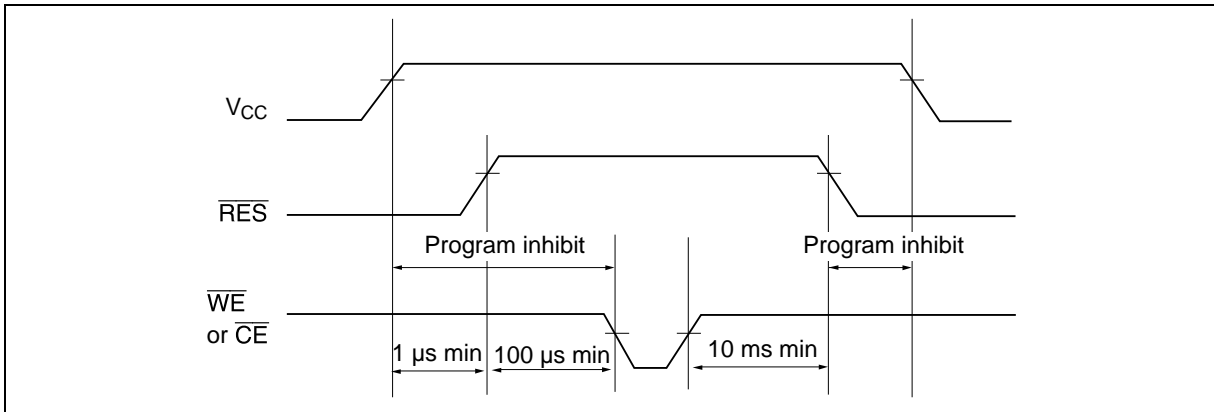

HN58C256A Series, HN58C257A Series

3. Software data protection

To prevent unintentional programming, this device has the software data protection (SDP) mode. The SDP is enabled by inputting the following 3 bytes code and write data. SDP is not enabled if only the 3 bytes code is input. To program data in the SDP enable mode, 3 bytes code must be input before write data.

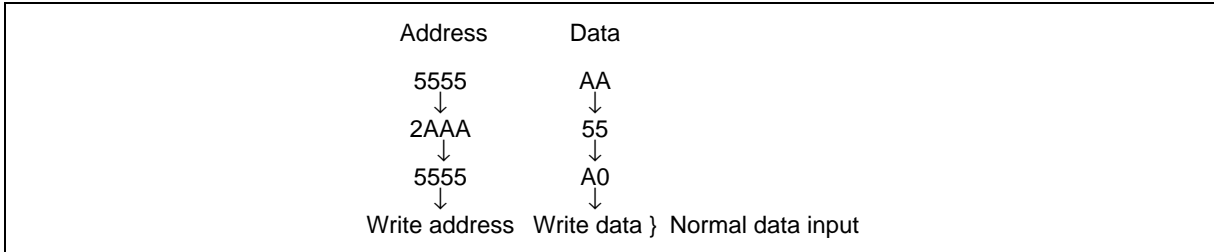

The SDP mode is disabled by inputting the following 6 bytes code. Note that, if data is input in the SDP disable cycle, data can not be written.

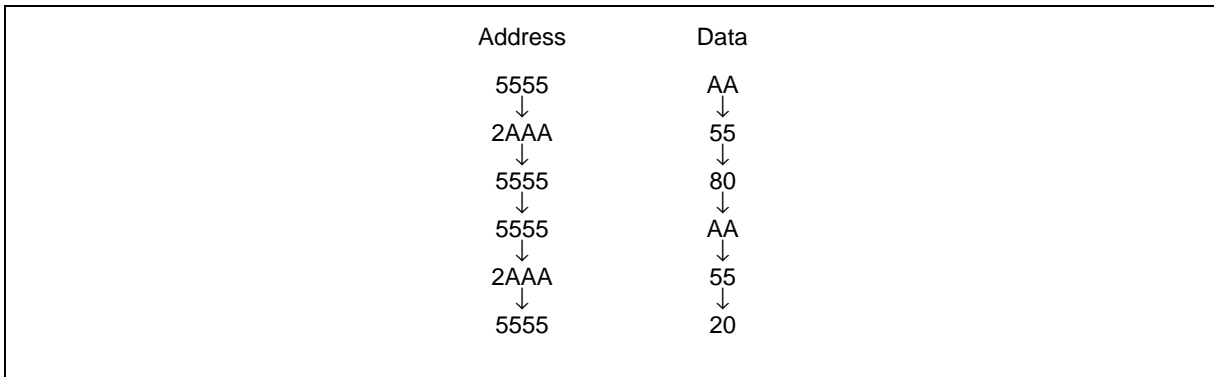

The software data protection is not enabled at the shipment.

Note: There are some differences between Renesas Technology's and other company's for enable/disable sequence of software data protection. If there are any questions, please contact with Renesas Technology's sales offices.

Package Dimensions

HN58C256AP Series (DP-28)

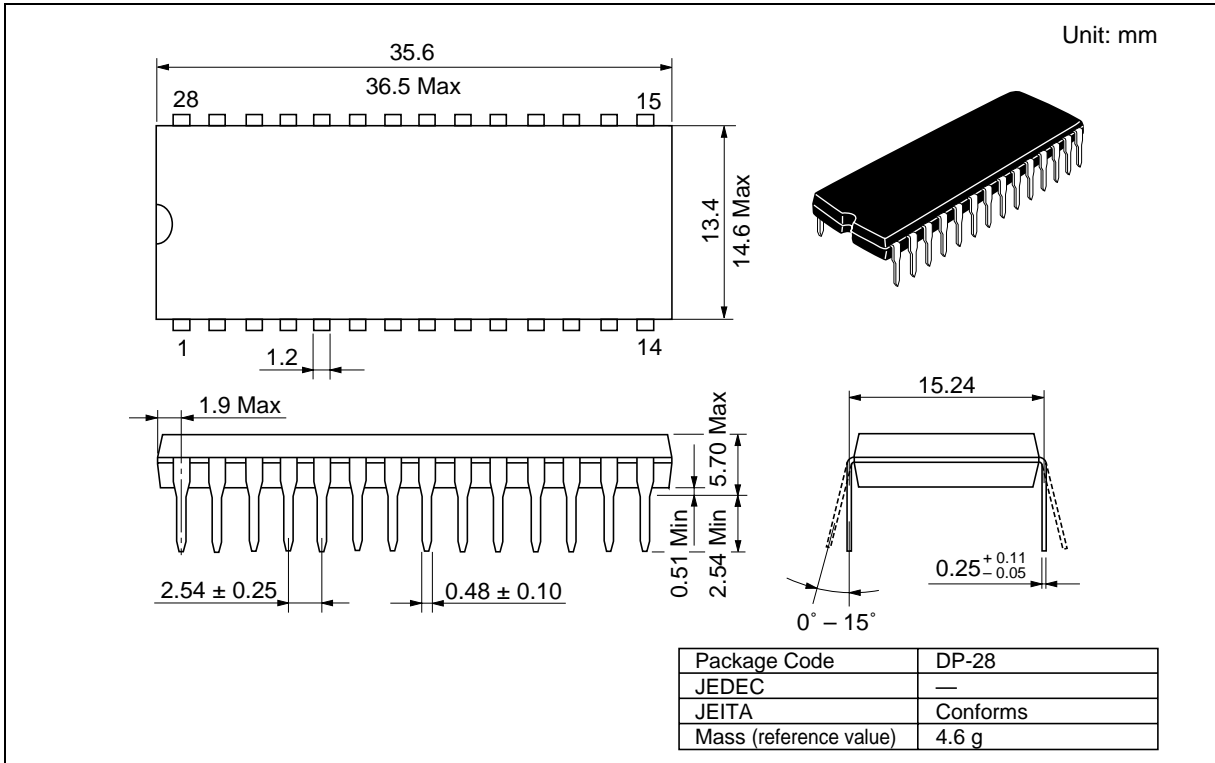

HN58C256A Series, HN58C257A Series

Package Dimensions (cont.)

HN58C256AFP Series (FP-28D, FP-28DV)

Unit: mm

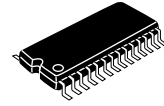
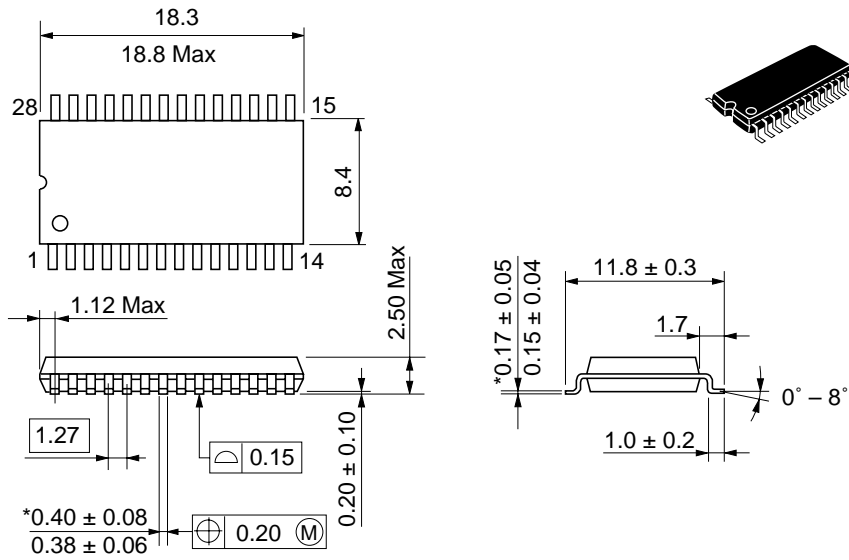

*Dimension including the plating thickness
Base material dimension

Package Code	FP-28D, FP-28DV
JEDEC	Conforms
JEITA	—
Mass (reference value)	0.7 g

HN58C256A Series, HN58C257A Series

Package Dimensions (cont.)

HN58C256AT Series (TFP-28DB, TFP-28DBV)

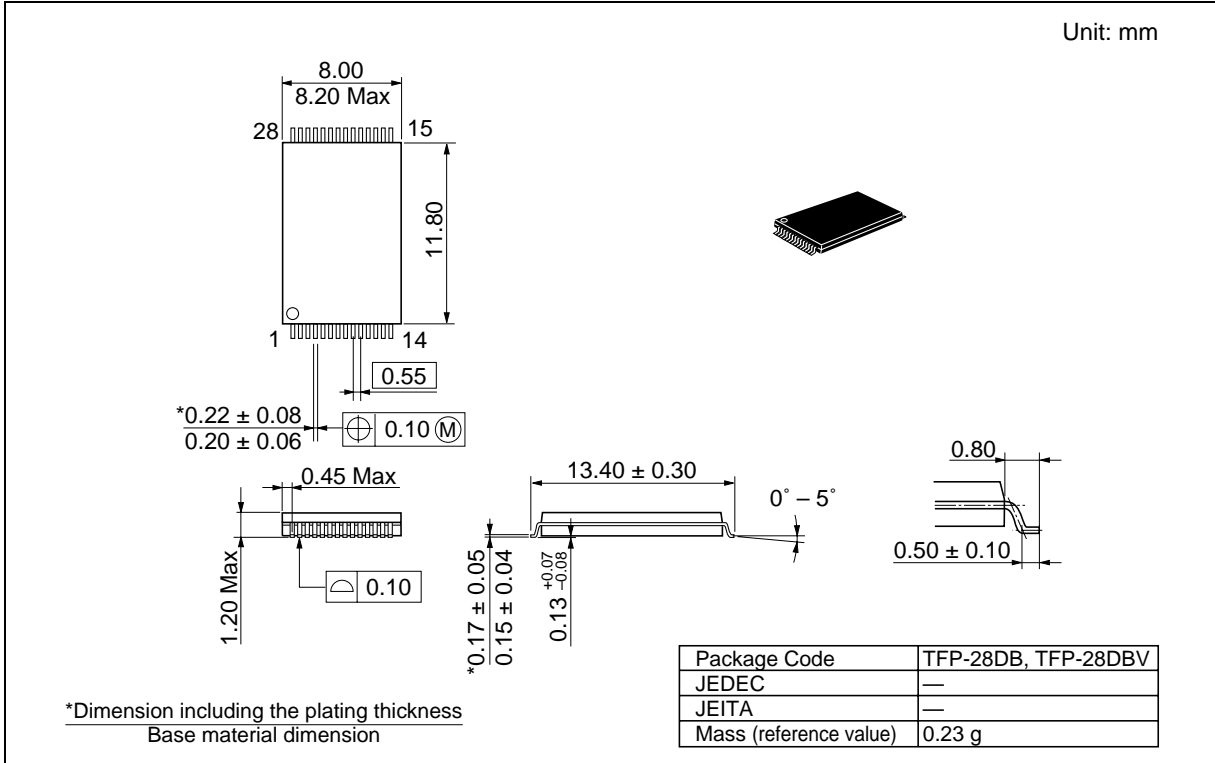

HN58C256A Series, HN58C257A Series

Package Dimensions (cont.)

HN58C257AT Series (TFP-32DA, TFP-32DAV)

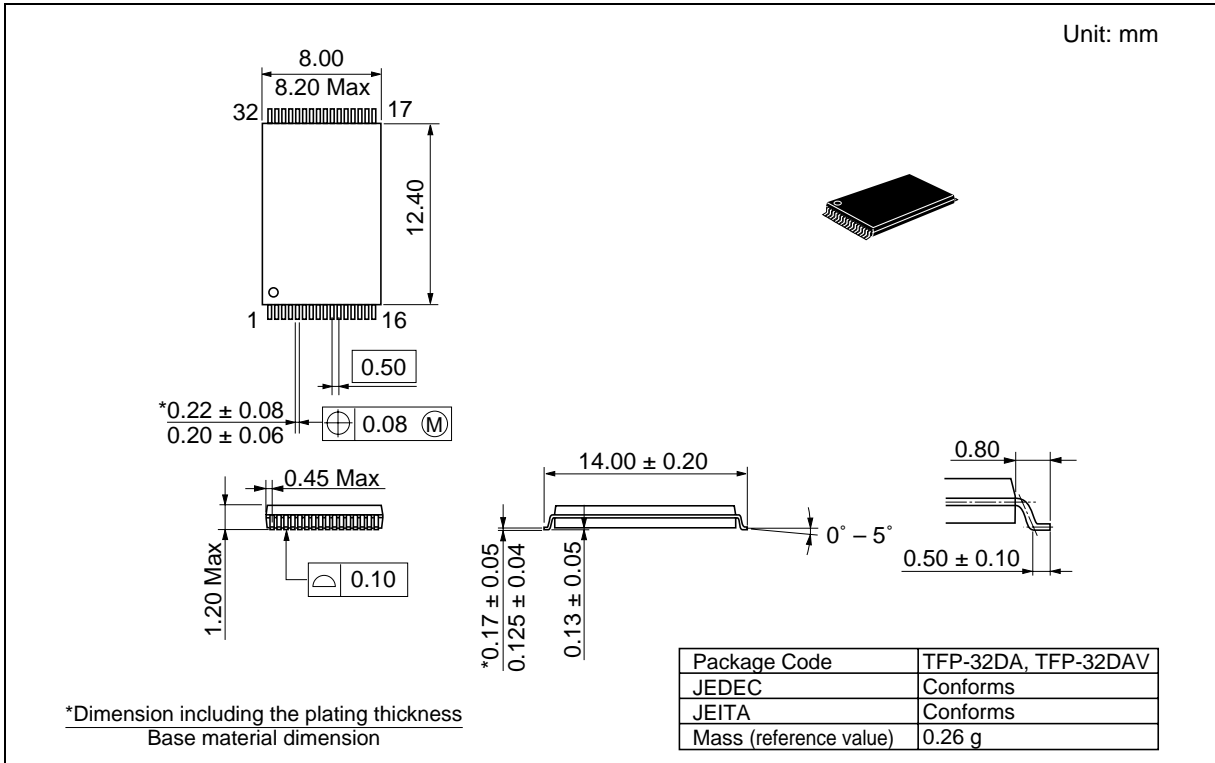

Revision History

HN58C256A/HN58C257A Series Data Sheet

Rev.	Date	Contents of Modification	
		Page	Description
0.0	Jun. 19. 1995	—	Initial issue
1.0	May. 17. 1996	—	Change of format
		4	Absolute Maximun Ratings Addition of note 4
		4	Recommended DC Operating Conditions V_{IH} (min): 3.0 V to 2.2 V
		5	DC Characteristics V_{OH} (min): $V_{CC} \times 0.8$ V to 2.4 V
		6	AC Characteristics Input pulse levels: 0 V to 3.0 V to 0.4 V to 3.0 V Data Polling Timing Waveform Addition of note 1 Toggle bit Waveform Addition of note 4
		2.0	Feb. 27. 1997
16	Functional Description Data Protection 3: Addition of note		
3.0	May. 20. 1997	16	Functional Description Data Protection 3: Change of Description
4.0	Oct. 24. 1997	8	Timing Waveforms Read Timing Waveform: Correct error
5.00	Nov. 17. 2003	—	Change format issued by Renesas Technology Corp.
		2	Ordering Information Addition of HN58C256AFP-85E, HN58C256AFP-10E, HN58C256AT-85E, HN58C256AT-10E, HN58C257AT-85E, HN58C257AT-10E
		20-23	Package Dimensions FP-28D to FP-28D, FP-28DV TFP-28DB to TFP-28DB, TFP-28DBV TFP-32DA to TFP-32DA, TFP-32DAV

RENESAS Technology Corp. Sales Strategic Planning Div. Nippon Bldg., 2-6-2, Ohte-machi, Chiyoda-ku, Tokyo 100-0004, Japan

Keep safety first in your circuit designs!

1. Renesas Technology Corp. puts the maximum effort into making semiconductor products better and more reliable, but there is always the possibility that trouble may occur with them. Trouble with semiconductors may lead to personal injury, fire or property damage.
Remember to give due consideration to safety when making your circuit designs, with appropriate measures such as (i) placement of substitutive, auxiliary circuits, (ii) use of nonflammable material or (iii) prevention against any malfunction or mishap.

Notes regarding these materials

1. These materials are intended as a reference to assist our customers in the selection of the Renesas Technology Corp. product best suited to the customer's application; they do not convey any license under any intellectual property rights, or any other rights, belonging to Renesas Technology Corp. or a third party.
 2. Renesas Technology Corp. assumes no responsibility for any damage, or infringement of any third-party's rights, originating in the use of any product data, diagrams, charts, programs, algorithms, or circuit application examples contained in these materials.
 3. All information contained in these materials, including product data, diagrams, charts, programs and algorithms represents information on products at the time of publication of these materials, and are subject to change by Renesas Technology Corp. without notice due to product improvements or other reasons. It is therefore recommended that customers contact Renesas Technology Corp. or an authorized Renesas Technology Corp. product distributor for the latest product information before purchasing a product listed herein.
The information described here may contain technical inaccuracies or typographical errors.
Renesas Technology Corp. assumes no responsibility for any damage, liability, or other loss rising from these inaccuracies or errors.
Please also pay attention to information published by Renesas Technology Corp. by various means, including the Renesas Technology Corp. Semiconductor home page (<http://www.renesas.com>).
 4. When using any or all of the information contained in these materials, including product data, diagrams, charts, programs, and algorithms, please be sure to evaluate all information as a total system before making a final decision on the applicability of the information and products. Renesas Technology Corp. assumes no responsibility for any damage, liability or other loss resulting from the information contained herein.
 5. Renesas Technology Corp. semiconductors are not designed or manufactured for use in a device or system that is used under circumstances in which human life is potentially at stake. Please contact Renesas Technology Corp. or an authorized Renesas Technology Corp. product distributor when considering the use of a product contained herein for any specific purposes, such as apparatus or systems for transportation, vehicular, medical, aerospace, nuclear, or undersea repeater use.
 6. The prior written approval of Renesas Technology Corp. is necessary to reprint or reproduce in whole or in part these materials.
 7. If these products or technologies are subject to the Japanese export control restrictions, they must be exported under a license from the Japanese government and cannot be imported into a country other than the approved destination.
Any diversion or reexport contrary to the export control laws and regulations of Japan and/or the country of destination is prohibited.
 8. Please contact Renesas Technology Corp. for further details on these materials or the products contained therein.
-



RENESAS SALES OFFICES

<http://www.renesas.com>

Renesas Technology America, Inc.
450 Holger Way, San Jose, CA 95134-1368, U.S.A
Tel: <1> (408) 382-7500 Fax: <1> (408) 382-7501

Renesas Technology Europe Limited.
Dukes Meadow, Millboard Road, Bourne End, Buckinghamshire, SL8 5FH, United Kingdom
Tel: <44> (1628) 585 100, Fax: <44> (1628) 585 900

Renesas Technology Europe GmbH
Dornacher Str. 3, D-85622 Feldkirchen, Germany
Tel: <49> (89) 380 70 0, Fax: <49> (89) 929 30 11

Renesas Technology Hong Kong Ltd.
7/F., North Tower, World Finance Centre, Harbour City, Canton Road, Hong Kong
Tel: <852> 2265-6688, Fax: <852> 2375-6836

Renesas Technology Taiwan Co., Ltd.
FL 10, #99, Fu-Hsing N. Rd., Taipei, Taiwan
Tel: <886> (2) 2715-2888, Fax: <886> (2) 2713-2999

Renesas Technology (Shanghai) Co., Ltd.
26/F., Ruijin Building, No.205 Maoming Road (S), Shanghai 200020, China
Tel: <86> (21) 6472-1001, Fax: <86> (21) 6415-2952

Renesas Technology Singapore Pte. Ltd.
1, Harbour Front Avenue, #06-10, Keppel Bay Tower, Singapore 098632
Tel: <65> 6213-0200, Fax: <65> 6278-8001



LittleDiode supplies new, hard to find or obsolete electronic components and semiconductors all over the world.

With over two million different components listed you are sure to find the part you need.

Feel free to visit us today at our online store:

LittleDiode.com

Looking forward to providing you with the best possible service.