

# LH2426

## Triple 80 MHz CRT Driver

### General Description

The LH2426 contains three wide bandwidth, large signal amplifiers designed for large voltage swings at high frequencies. The amplifiers work on a transimpedance principal i.e., an input current swing of  $\pm 4.38$  mA results in an output voltage swing of  $\pm 25$ V. The device is intended for use in color CRT monitors and is a low cost solution to designs conforming to the IBM® 8514 graphics standard.

### Features

- Operation from 80V power supply
- 80 MHz bandwidth at 50 V<sub>pp</sub> swings
- Rise/fall time less than 4 ns
- Output signal can swing 70V
- Drives CRT directly

### Applications

- CRT driver for RGB monitors
- High voltage transimpedance amplifiers

### Schematic and Connection Diagrams

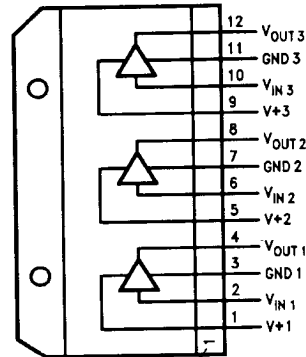
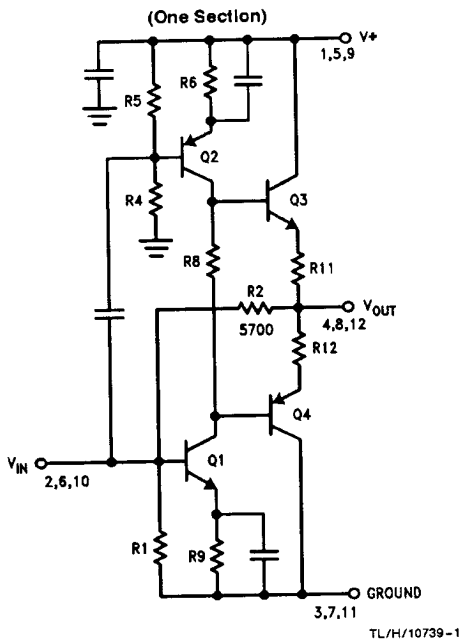

PIN 1 DESIGNATOR

TL/H/10739-2

Top View  
Order Number LH2426S  
See NS Package Number HY12B

IBM® is a registered trademark of International Business Machines Corporation.

## Absolute Maximum Ratings

If Military/Aerospace specified devices are required, please contact the National Semiconductor Sales Office/Distributors for availability and specifications.

Supply Voltage,  $V^+$  +85V  
Power Dissipation,  $P_D$  10W

Storage Temperature Range,  $T_{STG}$  -25°C to +100°C  
Operating Temperature Range,  $T_{CASE}$  -20°C to +90°C  
Lead Temperature (Soldering, 10 sec.) 300°C  
ESD Tolerance TBD

**DC Electrical Characteristics**  $V^+ = 80V$ ,  $R_1 = 430\Omega$ ,  $C_1 = 82\text{ pF}$ ,  $C_L = 8\text{ pF}$ , 50  $V_{pp}$  output swing with 40V DC offset. See Figure 1.  $T_{CASE} = 25^\circ\text{C}$  unless otherwise noted.

Symbol	Parameter	Conditions	LH2426			Units
			Min	Typical	Max	
$V^+$	Supply Current (per Amplifier)	No Input or Output Load		24	30	mA
$V_{INDC}$	Input Offset Voltage		1.4	1.6	1.8	V
$V_{OUTDC}$	Output Offset Voltage		34	40	46	V
$t_R$	Rise Time	10% to 90%		3.5	5	ns
$t_F$	Fall Time	90% to 10%		3.5	5	ns
BW	Bandwidth	-3 dB		100		MHz
$A_v$	Voltage Gain		11	13	14	V/V
OS	Overshoot			10		%
LE	Linearity Error	$V_{OUT}$ from +10V to +70V Note 1		5		%
$\Delta A_v$	Gain Matching	Note 2		0.2		dB

Note 1: Linearity error is defined as: The variation in small signal gain from +20V to +70V output with a 100 mVAC, 1 MHz, input signal.

Note 2: Calculated value from voltage gain test on each channel.

## Typical Performance Characteristics

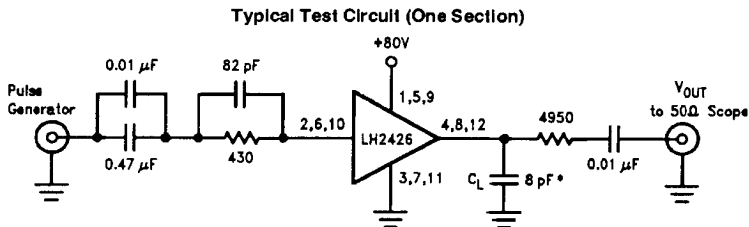

FIGURE 1. Test Circuit (One Section)

TL/H/10739-3

\*Note: 8 pF is total load capacitance. It includes all parasitic capacitances.

Figure 1 shows a typical test circuit for evaluation of the LH2426. This circuit is designed to allow testing of the LH2426 in a 50Ω environment such as a pulse generator, oscilloscope or network analyzer. To calibrate pulse generator, set to 2.4  $V_{pp}$  into 50Ω.

## Application Hints

The LH2426 is designed as a triple power amplifier for delivering red, blue and green video signals to a cathode ray tube (CRT). It can provide 50V output swing and energize a 12 ns pixel. The input capacitance of a CRT grid is typically 8 pF.

## THEORY OF OPERATION

The LH2426 is a two stage amplifier (see schematic on front page). Both stages are in push pull configuration.  $Q_2$  is biased with two resistors,  $Q_1$  gets its bias through the 5700Ω feedback resistor and the input biasing current. The bases of  $Q_1$  and  $Q_2$  are capacitively coupled and therefore  $Q_2$  is also actively driven.

The LH2426 is a transimpedance amplifier: an input current is translated into an output voltage. An input current of about  $\pm 4.5\text{ mA}$  will provide full output swing of  $\pm 25V$ . A resistor in series with the input converts the LH2426 into a voltage amplifier, with 430Ω the voltage gain becomes -13.

## Application Hints (Continued)

The emitter resistors of  $Q_1$  and  $Q_2$  are bypassed with small capacitors. This increases the gain to the stage for high frequencies and increases the bandwidth of the amplifier.

The power supply is internally bypassed. If low frequencies are present in the power supply line, an electrolytic capacitor is recommended.

### INPUT NETWORKS

The voltage gain and the response of the amplifiers can be set by adding an R-C to the input.

A  $430\Omega$  resistor in series, will set the voltage gain to 13. This will increase the rise and fall times of the system. (See Figure 2a) Bypassing the resistor with a capacitor of about  $50\text{ pF}$  will restore the rise/fall times but will result in some overshoot. (Figure 2b)

Adding a resistor in series with the capacitor will reduce the overshoot but also increase the rise and fall times. (Figure 2c)

The addition of a second capacitor will restore the rise and fall times without significant overshoot. (Figure 2d)

Suggested values for the resistors and capacitors are shown, however, optimum values may differ depending upon the stray inductances and capacitances present in different board layouts.

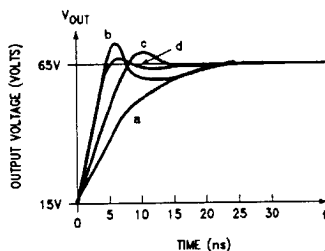

TL/H/10739-8

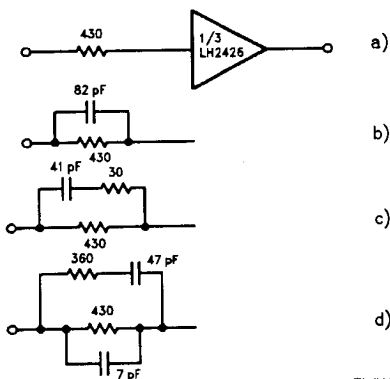

TL/H/10739-9

**FIGURE 2. Influence of Input Networks on Switching Performance**

Figure 2 compares different input networks and their influence on the switching waveform.

### DROOP COMPENSATION

When low frequency square waves are amplified, some droop will occur due to the large change in the thermal

dissipation in the input transistors. If this causes a problem, it can be compensated with R-C feedback. Figure 3 illustrates the circuit and recommended component values.

### PROTECTING AMPLIFIER OUTPUT FROM TUBE ARCING

During normal CRT operation, internal arcing may occasionally occur. Spark gap protectors do limit the maximum voltage, but to a value that is much higher than allowable on the LH2426. This fast, high voltage, high current pulse can damage the LH2426 output. The addition of a current limiting resistor of  $50\Omega$  to  $100\Omega$  will provide protection but will slow down response. Adding a series peaking inductor of  $100\text{ nH}$  to  $150\text{ nH}$  will restore the bandwidth and provide additional protection. (See Figure 3)

The value of the inductor can be calculated from:

$$L_p = \left[ \frac{(R_0 + R_D)^2}{2.4} \right] C$$

where C is the total load and  $R_0$  is the intrinsic high frequency output resistance of the amplifier, generally  $160\Omega$ .

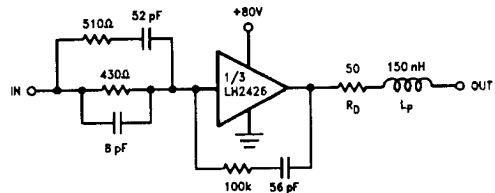

TL/H/10739-7

**FIGURE 3. One Section of the LH2426 with Damping Resistor  $R_D$  and Peaking Inductance  $L_p$  in the Output**

### SUPPLY BYPASSING

Although the LH2426 has internal supply bypassing, some values of supply line inductance can cause ringing in the supply lines. If this occurs, an additional bypass capacitor or a low-pass filter should be placed near the supply pins.

### CAPACITIVE LOADS

The LH2426 is designed to drive capacitive loads, however the very high output slew rate of about  $13,700\text{ V}/\mu\text{s}$  can result in charging currents of over  $200\text{ mA}$  into a  $20\text{ pF}$  load. These very high currents can damage the output transistors.

### SHORT CIRCUIT PROTECTION

Warning! To provide maximum output speed, the LH2426 does not have short circuit protection. Shorting the output can destroy the device. The lowest value load the LH2426 is designed to drive is  $600\Omega$ . If the device is used in an application where the output may be shorted,  $600\Omega$  should be placed in series with the output.

### HEAT SINKING

As the LH2426 will dissipate up to  $10\text{ W}$ , an external heat-sink is always required. The maximum allowed case temperature is  $90^\circ\text{C}$ . To calculate maximum heatsink thermal resistance, use the following formula:

$$R_{th} = (90^\circ\text{C} - \text{Max Ambient})/10$$

# Physical Dimensions inches (millimeters)

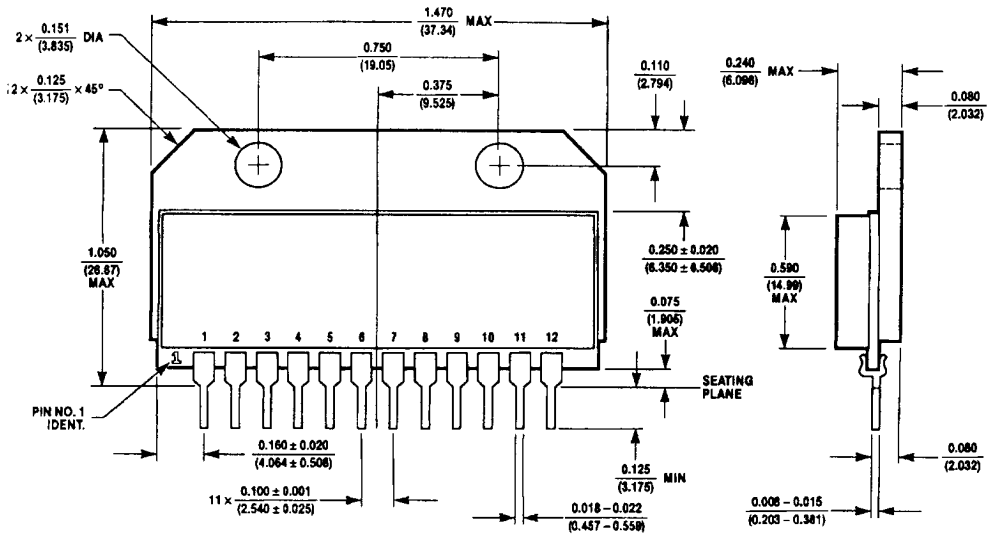

Note 1: Substrate: 96% alumina.

Note 2: Lid seal: epoxy.

Note 3: Leads: phos. bronze alloy or equiv. with 95 Sn/5 Ag solder DIP.

Note 4: Four radius bumps on corners of lid are optional. Not shown on drawing.

HY12B (REV A)

Order Number LH2426S  
NS Package Number HY12B

## LIFE SUPPORT POLICY

NATIONAL'S PRODUCTS ARE NOT AUTHORIZED FOR USE AS CRITICAL COMPONENTS IN LIFE SUPPORT DEVICES OR SYSTEMS WITHOUT THE EXPRESS WRITTEN APPROVAL OF THE PRESIDENT OF NATIONAL SEMICONDUCTOR CORPORATION. As used herein:

1. Life support devices or systems are devices or systems which, (a) are intended for surgical implant into the body, or (b) support or sustain life, and whose failure to perform, when properly used in accordance with instructions for use provided in the labeling, can be reasonably expected to result in a significant injury to the user.
2. A critical component is any component of a life support device or system whose failure to perform can be reasonably expected to cause the failure of the life support device or system, or to affect its safety or effectiveness.



National Semiconductor Corporation  
2800 Semiconductor Drive  
P.O. Box 58080  
Santa Clara, CA 95052-8080  
Tel: (408) 721-5000  
TWX: (910) 336-9240

National Semiconductor GmbH  
Industriestrasse 10  
D-8080 Furstenfeldbruck  
West Germany  
Tel: (0-81-41) 103-0  
Telex: 527-648  
Fax: (08141) 103554

National Semiconductor Japan Ltd.  
Sanseido Bldg. 5F  
4-15 Nishi Shinjuku  
Shinjuku-Ku,  
Tokyo 160, Japan  
Tel: 3-299-7001  
FAX: 3-299-7000

National Semiconductor Hong Kong Ltd.  
Suite 513, 5th Floor  
Chinachem Golden Plaza,  
77 Mody Road, Tsimshatsui East,  
Kowloon, Hong Kong  
Tel: 3-7231280  
Telex: 52986 NSSEA HX  
Fax: 3-3112536

National Semicondutora do Brasil Ltda.  
Av. Eng. Faria Lima, 1383  
6.0 Andor-Conj. 82  
01451 Sao Paulo, SP, Brasil  
Tel: (55/11) 212-5066  
Fax: (55/11) 211-1181 NSBR BR

National Semiconductor (Australia) Pty, Ltd.  
1st Floor, 441 St. Kilda Rd.  
Melbourne, 3004  
Victoria, Australia  
Tel: (03) 267-5000  
Fax: 61-3-2677458

National does not assume any responsibility for use of any circuitry described, no circuit patent licenses are implied and National reserves the right at any time without notice to change said circuitry and specifications.  
© 1990 National Semiconductor Corporation