

HSP43891

Pinout

85 PIN GRID ARRAY (PGA)

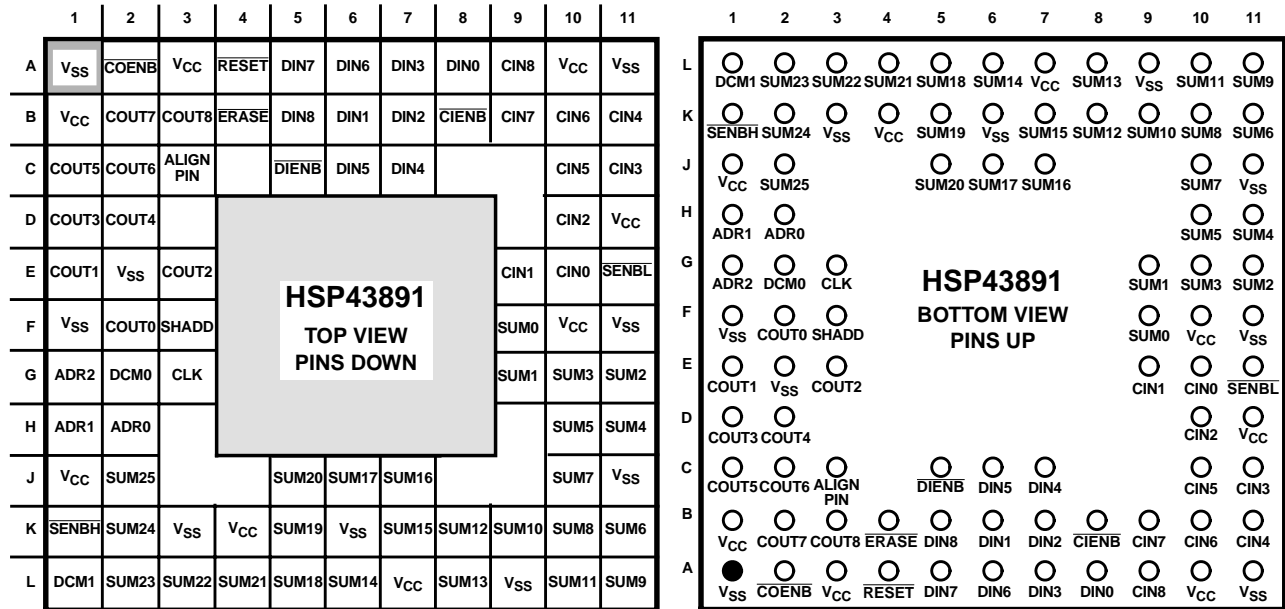

84 LEAD PLASTIC LEADED CHIP CARRIER (PLCC)

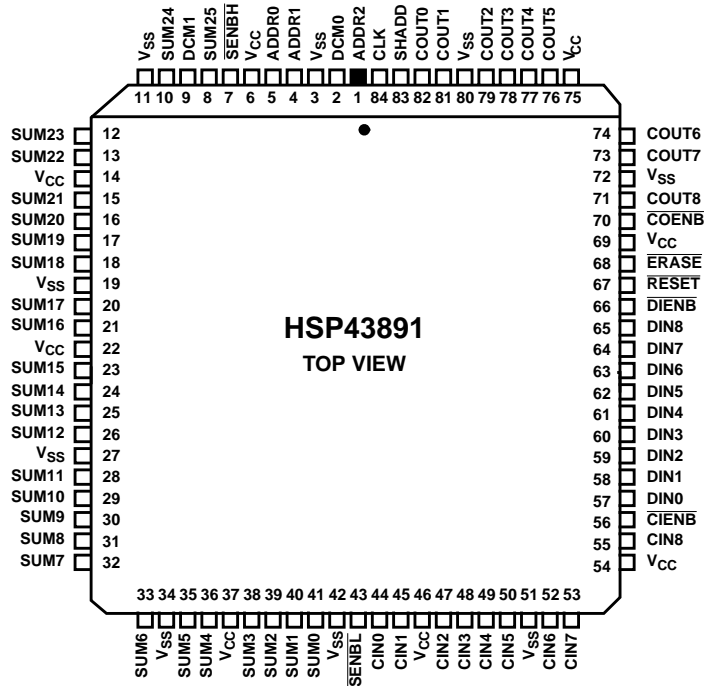

HSP43891

Pinout (Continued)

100 LEAD MQFP TOP VIEW

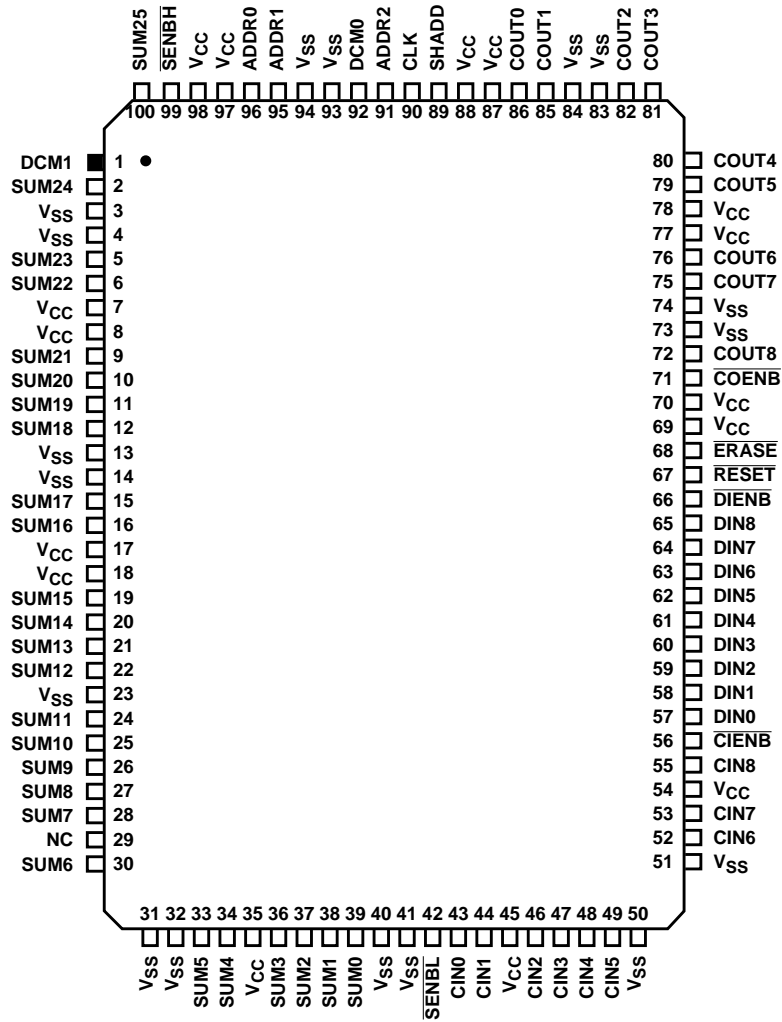

Pin Description

SYMBOL	PIN NUMBER	TYPE	NAME AND FUNCTION															
V _{CC}	B1, J1, A3, K4, L7, A10, F10, D11		+5 power supply input.															
V _{SS}	A1, F1, E2, K3, K6, L9, A11, F11, J11		Power supply ground input.															
CLK	G3	I	The CLK input provides the DF system sample clock. The maximum clock frequency is 30MHz.															
DIN0-8	A5-8, B5-7, C6, C7	I	These nine inputs are the data sample input bus. Nine-bit data samples are synchronously loaded through these pins to the X register of each filter cell of the DF simultaneously. The \overline{DIENB} signal enables loading, which is synchronous on the rising edge of the clock signal. The data samples can be either 9-bit two's complement or 8-bit unsigned values. For 9-bit two's complement values, DIN8 is the sign bit. For 8-bit unsigned values, DIN8 must be held at logical zero.															
\overline{DIENB}	C5	I	A low on this input enables the data sample input bus (DIN0-8) to all the filter cells. A rising edge of the CLK signal occurring while \overline{DIENB} is low will load the X register of every filter cell with the 9-bit value present on DIN0-8. A high on this input forces all the bits of the data sample input bus to zero; a rising CLK edge when \overline{DIENB} is high will load the X register of every filter cell with all zeros. This signal is latched inside the device, delaying its effect by one clock internal to the device. Therefore it must be low during the clock cycle immediately preceding presentation of the desired data on the DIN0-8 inputs. Detailed operation is shown in later timing diagrams.															
CIN0-8	A9, B9-11, C10, C11, D10, E9, E10	I	These nine inputs are used to input the 9-bit coefficients. The coefficients are synchronously loaded into the C register of filter CELL0 if a rising edge of CLK occurs while \overline{CIENB} is low. The \overline{CIENB} signal is delayed by one clock as discussed below. The coefficients can be either 9-bit two's complement or 8-bit unsigned values. For 9-bit two's complement values, CIN8 is the sign bit. For 8-bit unsigned values, CIN8 must be held at logical zero.															
ALIGN PIN	C3		Used for aligning chip on socket or printed circuit board. This pin must be left as a no connect in circuit.															
\overline{CIENB}	B8	I	A low on this input enables the C register of every filter cell and the D (decimation) registers of every filter cell according to the state of the DCM0-1 inputs. A rising edge of the CLK signal occurring while \overline{CIENB} is low will load the C register and appropriate D registers with the coefficient data present at their inputs. This provides the mechanism for shifting coefficients from cell to cell through the device. A high on this input freezes the contents of the C register and the D registers, ignoring the CLK signal. This signal is latched and delayed by one clock internal to the DF. Therefore it must be low during the clock cycle immediately preceding presentation of the desired coefficient on the CIN0-8 inputs. Detailed operation is shown in later timing diagrams.															
COUT0-8	B2, B3, C1, D1, E1, C2, D2, F2, E3	O	These nine three-state outputs are used to output the 9-bit coefficients from filter CELL7. These outputs are enabled by the \overline{COENB} signal low. These outputs may be tied to the CIN0-8 inputs of the same DF to recirculate to coefficients, or they may be tied to the CIN0-8 inputs of another DF to cascade DFs for longer filter lengths.															
\overline{COENB}	A2	I	A low on the \overline{COENB} input enables the COUT0-8 outputs. A high on this input places all these outputs in their high impedance state.															
DCM0-1	L1, G2	I	These two inputs determine the use of the internal decimation registers as follows: <table border="1" style="margin-left: 20px;"> <thead> <tr> <th>DCM1</th> <th>DCM0</th> <th>DECIMATION FUNCTION</th> </tr> </thead> <tbody> <tr> <td>0</td> <td>0</td> <td>Decimation registers not used</td> </tr> <tr> <td>0</td> <td>1</td> <td>One decimation register is used</td> </tr> <tr> <td>1</td> <td>0</td> <td>Two decimation registers are used</td> </tr> <tr> <td>1</td> <td>1</td> <td>Three decimation registers are used</td> </tr> </tbody> </table> <p>The coefficients pass from cell to cell at a rate determined by the number of decimation registers used. When no decimation registers are used, coefficients move from cell to cell on each clock. When one decimation register is used, coefficients move from cell to cell on every other clock, etc. These signals are latched and delayed by one clock internal to the device.</p>	DCM1	DCM0	DECIMATION FUNCTION	0	0	Decimation registers not used	0	1	One decimation register is used	1	0	Two decimation registers are used	1	1	Three decimation registers are used
DCM1	DCM0	DECIMATION FUNCTION																
0	0	Decimation registers not used																
0	1	One decimation register is used																
1	0	Two decimation registers are used																
1	1	Three decimation registers are used																

Pin Description (Continued)

SYMBOL	PIN NUMBER	TYPE	NAME AND FUNCTION
SUM0-25	F9, G9-G11, H10, H11, J2, J5-J7, J10, K2, K5, K7-K11, L2-L6, L8, L10, L11	O	These 26 three-state outputs are used to output the results of the internal filter cell computations. Individual filter cell results or the result of the shift and add output stage can be output. If an individual filter cell result is to be output, the ADR0-2 signals select the filter cell result. The SHADD signal determines whether the selected filter cell result or the output stage adder result is output. The signals $\overline{\text{SENBH}}$ and $\overline{\text{SENBL}}$ enable the most significant and least significant bits of the SUM0-25 result respectively. Both $\overline{\text{SENBH}}$ and $\overline{\text{SENBL}}$ may be enabled simultaneously if the system has a 26-bit or larger bus. However individual enables are provided to facilitate use with a 16-bit bus.
$\overline{\text{SENBH}}$	K1	I	A low on this input enables result bits SUM16-25. A high on this input places these bits in their high impedance state.
$\overline{\text{SENBL}}$	E11	I	A low on this input enables result bits SUM0-15. A high on this input places these bits in their high impedance state.
ADR0-2	G1, H1, H2	I	These three inputs select the one cell whose accumulator will be read through the output bus (SUM0-25) or added to the output stage accumulator. They also determine which accumulator will be cleared when $\overline{\text{ERASE}}$ is low. These inputs are latched in the DF and delayed by one clock internal to the device. If ADR0-2 remains at the same address for more than one clock, the output at SUM0-25 will not change to reflect any subsequent accumulator updates in the addressed cell. Only the result available during the first clock, when ADR0-2 selects the cell, will be output. This does not hinder normal operation since the ADR0-2 lines are changed sequentially. This feature facilitates the interface with slow memories where the output is required to be fixed for more than one clock.
SHADD	F3	I	The SHADD input controls the activation of the shift and add operation in the output stage. This signal is latched on chip and delayed by one clock internal to the device. Detailed explanation is given in the DF Output Stage section.
$\overline{\text{RESET}}$	A4	I	A low on this input synchronously clears all the internal registers, except the cell accumulators. It can be used with $\overline{\text{ERASE}}$ to also clear all the accumulators simultaneously. This signal is latched in the DF and delayed by one clock internal to the device.
$\overline{\text{ERASE}}$	B4	I	A low on this input synchronously clears the cell accumulator selected by the ADR0-2 signals. If $\overline{\text{RESET}}$ is also low simultaneously, all cell accumulators are cleared.

Functional Description

The Digital Filter Processor (DF) is composed of eight filter cells cascaded together and an output stage for combining or selecting filter cell outputs (See Block Diagram). Each filter cell contains a multiplier-accumulator and several registers (Figure 1). Each 9-bit coefficient is multiplied by a 9-bit data sample, with the result added to the 26-bit accumulator contents. The coefficient output of each cell is cascaded to the coefficient input of the next cell to its right.

DF Filter Cell

A 9-bit coefficient (CIN0-8) enters each cell through the C register on the left and exits the cell on the right as signals COUT0-8. With no decimation, the coefficient moves directly from the C register to the output, and is valid on the clock following its entrance. When decimation is selected the coefficient exit is delayed by 1, 2 or 3 clocks by passing through one or more decimation registers (D1, D2 or D3).

The combination of D registers through which the coefficient passes is determined by the state of DCM0 and DCM1. The output signals (COUT0-8) are connected to the CIN0-8 inputs of the next cell to its right. The $\overline{\text{COENB}}$ input signal enables the COUT0-8 outputs of the right most cell to the COUT0-8 pins of the device.

The C and D registers are enabled for loading by $\overline{\text{CIENB}}$. Loading is synchronous with CLK when $\overline{\text{CIENB}}$ is low. Note that $\overline{\text{CIENB}}$ is latched internally. It enables the register for loading after the next CLK following the onset of $\overline{\text{CIENB}}$ low. Actual loading occurs on the second CLK following the onset of $\overline{\text{CIENB}}$ low. Therefore $\overline{\text{CIENB}}$ must be low during the clock cycle immediately preceding presentation of the coefficient on the CIN0-8 inputs. In most basic FIR operations, $\overline{\text{CIENB}}$ will be low throughout the process, so this latching and delay sequence is only important during the initialization phase. When $\overline{\text{CIENB}}$ is high, the coefficients are frozen.

The C and D registers are cleared synchronously under control of $\overline{\text{RESET}}$, which is latched and delayed exactly like $\overline{\text{CIENB}}$. The output of the C register (C0-8) is one input to 9 x 9 multiplier.

The other input to the 9 x 9 multiplier comes from the output of the X register. This register is loaded with a data sample from the device input signals DIN0-8 discussed above. The X register is enabled for loading by $\overline{\text{DIENB}}$. Loading is synchronous with CLK when $\overline{\text{DIENB}}$ is low. Note that $\overline{\text{DIENB}}$ is latched internally. It enables the register for loading after the next CLK following the onset of $\overline{\text{DIENB}}$ low. Actual loading occurs on the second CLK following the onset of $\overline{\text{DIENB}}$ low; therefore, $\overline{\text{DIENB}}$ must be low during the clock

cycle immediately preceding presentation of the data sample on the DIN0-8 inputs. In most basic FIR operations, $\overline{\text{DIENB}}$ will be low throughout the process, so this latching and delay sequence is only important during the initialization phase. When $\overline{\text{DIENB}}$ is high, the X register is loaded with all zeros.

The multiplier is pipelined and is modeled as a multiplier core followed by two pipeline registers, MREG0 and MREG1 (Figure 1). The multiplier output is sign extended and input as one operand of the 26-bit adder. The other adder operand is the output of the 26-bit accumulator. The adder output is loaded synchronously into both the accumulator and the TREG.

The TREG loading is disabled by the cell select signal, CELL_n , where n is the cell number. The cell select is decoded from the ADR0-2 signals to generate the TREG load enable. The cell select is inverted and applied as the load enable to the TREG. Operation is such that the TREG is loaded whenever the cell is not selected. Therefore, TREG is loaded every clock except the clock following cell selection. The purpose of the TREG is to hold the result of a sum-of-products calculation during the clock when the accumulator is cleared to prepare for the next sum-of-products calculation. This allows continuous accumulation without wasting clocks.

The accumulator is loaded with the adder output every clock unless it is cleared. It is cleared synchronously in two ways. When $\overline{\text{RESET}}$ and $\overline{\text{ERASE}}$ are both low, the accumulator is cleared along with all other registers on the device. Since $\overline{\text{ERASE}}$ and $\overline{\text{RESET}}$ are latched and delayed one clock internally, clearing occurs on the second CLK following the onset of both $\overline{\text{ERASE}}$ and $\overline{\text{RESET}}$ low.

The second accumulator clearing mechanism clears a single accumulator in a selected cell. The cell select signal, CELL_n , decoded from ADR0-2 and the $\overline{\text{ERASE}}$ signal enable clearing of the accumulator on the next CLK.

The $\overline{\text{ERASE}}$ and $\overline{\text{RESET}}$ signals clear the DF internal registers and states as follows:

ERASE	RESET	CLEARING EFFECT
1	1	No clearing occurs, internal state remains same.
1	0	$\overline{\text{RESET}}$ only active, all registers except accumulators are cleared, including the internal pipeline registers.
0	1	$\overline{\text{ERASE}}$ only active, the accumulator whose address is given by the ADR0-2 inputs is cleared.
0	0	Both $\overline{\text{RESET}}$ and $\overline{\text{ERASE}}$ active, all accumulators as well as all other registers are cleared.

The DF Output Stage

The output stage consists of a 26-bit adder, 26-bit register, feedback multiplexer from the register to the adder, an output multiplexer and a 26-bit three-state driver stage (Figure 2).

The 26-bit output adder can add any filter cell accumulator result to the 18 most significant bits of the output buffer. This result is stored back in the output buffer. This operation takes place in one clock period. The eight LSBs of the output buffer are lost. The filter cell accumulator is selected by the ADR0-2 inputs.

The 18 MSBs of the output buffer actually pass through the zero mux on their way to the output adder input. The zero mux is controlled by the SHADD input signal and selects either the output buffer 18 MSBs or all zeros for the adder input. A low on the SHADD input selects zero. A high on the SHADD input selects the output buffer MSBs, thus, activating the shift-and-add operation. The SHADD signal is latched and delayed by one clock internally.

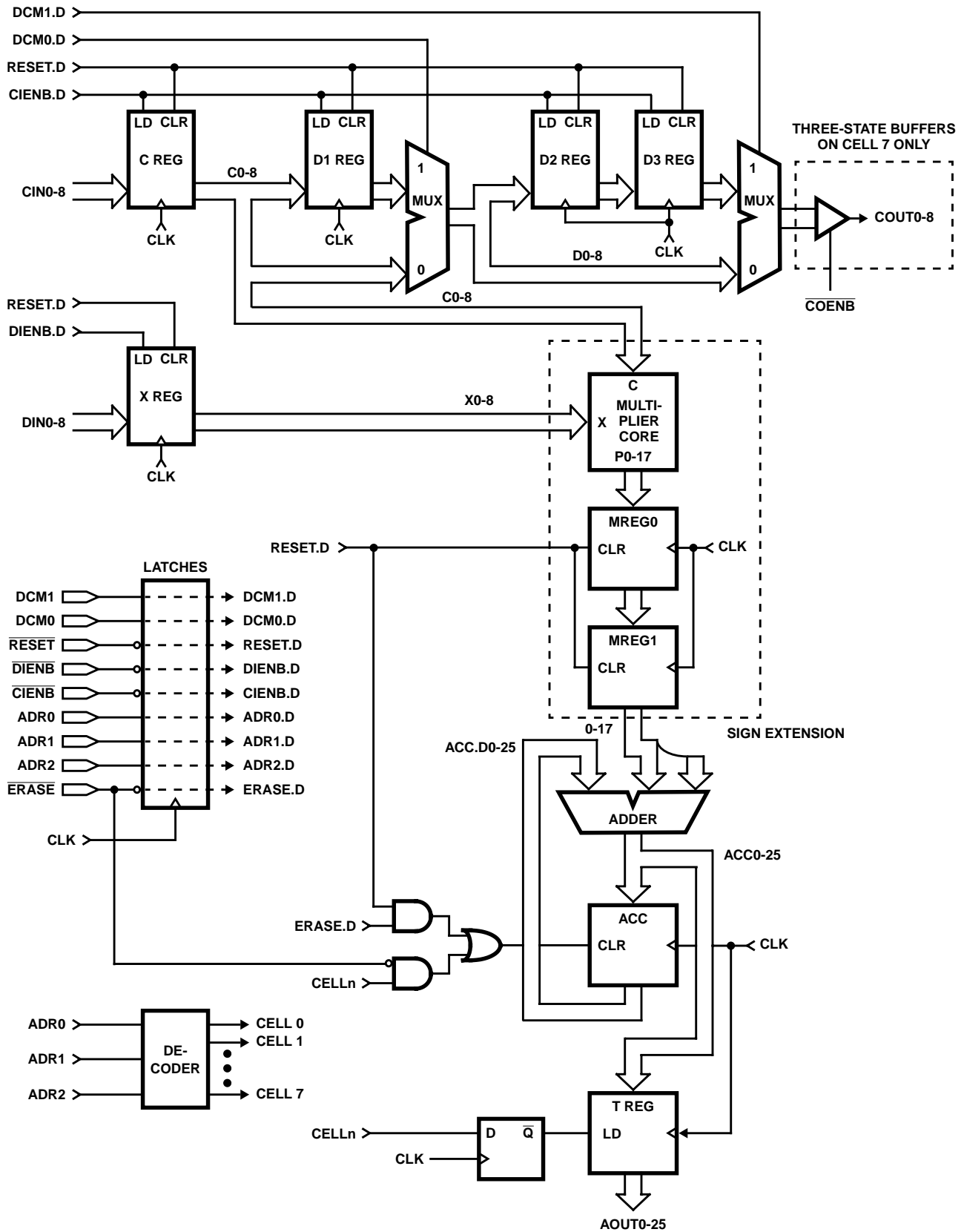

FIGURE 1. HSP43891 DF FILTER CELL

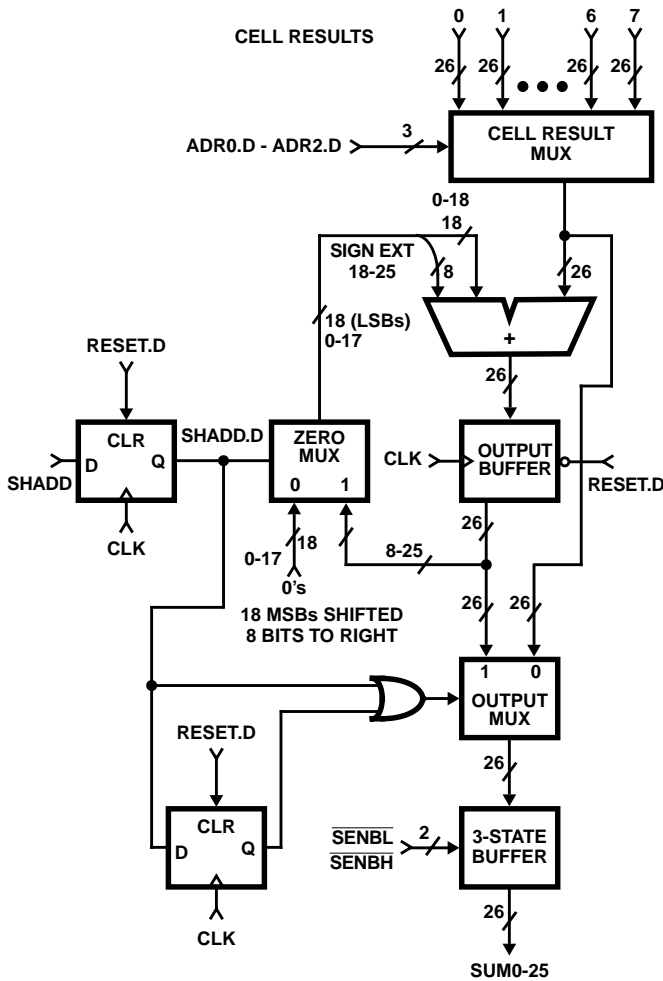

FIGURE 2. HSP43891 DFP OUTPUT STAGE

The 26 least significant bits (LSBs) from either a cell accumulator or the output buffer are output on the SUM0-25 bus. The output mux determines whether the cell accumulator selected by ADR0-2 or the output buffer is output to the bus. This mux is controlled by the SHADD input signal. Control is based on the state of the SHADD during two successive clocks; in other words, the output mux selection contains memory. If SHADD is low during a clock cycle and was low during the previous clock, the output mux selects the contents of the filter cell accumulator addressed by ADR0-2. Otherwise the output mux selects the contents of the output buffer.

If the ADR0-2 lines remain at the same address for more than one clock, the output at SUM0-25 will not change to reflect any subsequent accumulator updates in the addressed cell. Only the result available during the first clock when ADR0-2 selects the cell will be output.

This does not hinder normal FIR operation since the ADR0-2 lines are changed sequentially. This feature facilitates the interface with slow memories where the output is required to be fixed for more than one clock.

The SUM0-25 output bus is controlled by the $\overline{\text{SENBH}}$ and $\overline{\text{SENBL}}$ signals. A low on $\overline{\text{SENBL}}$ enables bits SUM0-15. A low on $\overline{\text{SENBH}}$ enables bits SUM16-25. Thus, all 26 bits can be output simultaneously if the external system has a 26-bit or larger bus. If the external system bus is only 16 bits, the bits can be enabled in two groups of 16 and 10 bits (sign extended).

DF Arithmetic

Both data samples and coefficients can be represented as either 8-bit unsigned or 9-bit two's complement numbers. The 9x9 bit multiplier in each cell expects 9-bit two's complement operands. The binary format of 8-bit two's complement is shown below. Note that if the most significant or sign bit is held at logical zero, the 9-bit two's complement multiplier can multiply 8-bit unsigned operands. Only the upper (positive) half of the two's complement binary range is used.

The multiplier output is 18 bits and the accumulator is 26 bits. The accumulator width determines the maximum possible number of terms in the sum of products without overflow. The maximum number of terms depends also on the number system and the distribution of the coefficient and data values. Then maximum numbers of terms in the sum products are:

NUMBER SYSTEM	MAXIMUM # OF TERMS	
	8-BIT	9-BIT
Two Unsigned Vectors	1032	N/A
Two Two's Complement Vectors		
• Two Positive Vectors	2080	1032
• Negative Vectors	2047	1024
• One Positive and One Negative Vector	2064	1028
One Unsigned 8-Bit Vector and One Two's Complement Vector		
• Positive Two's Complement Vector	1036	1032
• Negative Two's Complement Vector	1028	1028

For practical FIR filters, the coefficients are never all near maximum value, so even larger vectors are possible in practice.

Basic FIR Operation

A simple, 30MHz 8-tap filter example serves to illustrate more clearly the operation of the DF. The sequence table (Table 1) shows the results of the multiply accumulate in each cell after each clock. The coefficient sequence, C_N , enters the DF on the left and moves from left to right through the cells. The data sample sequence, X_N , enters the DF from the top, with each cell receiving the same sample simultaneously. Each cell accumulates the sum of products for one output point. Eight sums of products are calculated simultaneously, but staggered in time so that a new output is available every system clock.

HSP43891

TABLE 1. HSP43891 30MHz, 8-TAP FIR FILTER SEQUENCE

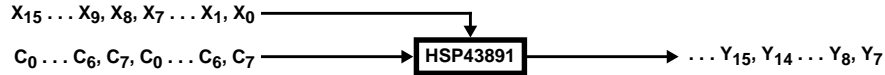

CLK	CELL 0	CELL 1	CELL 2	CELL 3	CELL 4	CELL 5	CELL 6	CELL 7	SUM/CLR
0	$C_7 \times X_0$	0	0	0	-	-	-	-	-
1	$+C_6 \times X_1$	$C_7 \times X_1$	0	0	-	-	-	-	-
2	$+C_5 \times X_2$	$+C_6 \times X_2$	$C_7 \times X_2$	0	-	-	-	-	-
3	$+C_4 \times X_3$	$+C_5 \times X_3$	$+C_6 \times X_3$	$C_7 \times X_3$	-	-	-	-	-
4	$+C_3 \times X_4$	$+C_4 \times X_4$	$+C_5 \times X_4$	$+C_6 \times X_4$	$C_7 \times X_4$	-	-	-	-
5	$+C_2 \times X_5$	$+C_3 \times X_5$	$+C_4 \times X_5$	$+C_5 \times X_5$	$+C_6 \times X_5$	$C_7 \times X_5$	-	-	-
6	$+C_1 \times X_6$	$+C_2 \times X_6$	$+C_3 \times X_6$	$+C_4 \times X_6$	$+C_5 \times X_6$	$+C_6 \times X_6$	$C_7 \times X_6$	-	-
7	$+C_0 \times X_7$	$+C_1 \times X_7$	$+C_2 \times X_7$	$+C_3 \times X_7$	$+C_4 \times X_7$	$+C_5 \times X_7$	$+C_6 \times X_7$	$C_7 \times X_7$	Cell 0 (Y_7)
8	$C_7 \times X_8$	$+C_0 \times X_8$	$+C_1 \times X_8$	$+C_2 \times X_8$	$+C_3 \times X_8$	$+C_4 \times X_8$	$+C_5 \times X_8$	$+C_6 \times X_8$	Cell 1 (Y_8)
9	$+C_6 \times X_9$	$C_7 \times X_9$	$+C_0 \times X_9$	$+C_1 \times X_9$	$+C_2 \times X_9$	$+C_3 \times X_9$	$+C_4 \times X_9$	$+C_5 \times X_9$	Cell 2 (Y_9)
10	$+C_5 \times X_{10}$	$+C_6 \times X_{10}$	$C_7 \times X_{10}$	$+C_0 \times X_{10}$	$+C_1 \times X_{10}$	$+C_2 \times X_{10}$	$+C_3 \times X_{10}$	$+C_4 \times X_{10}$	Cell 3 (Y_{10})
11	$+C_4 \times X_{11}$	$+C_5 \times X_{11}$	$+C_6 \times X_{11}$	$C_7 \times X_{11}$	$+C_0 \times X_{11}$	$+C_1 \times X_{11}$	$+C_2 \times X_{11}$	$+C_3 \times X_{11}$	Cell 4 (Y_{11})
12	$+C_3 \times X_{12}$	$+C_4 \times X_{12}$	$+C_5 \times X_{12}$	$+C_6 \times X_{12}$	$C_7 \times X_{12}$	$+C_0 \times X_{12}$	$+C_1 \times X_{12}$	$+C_2 \times X_{12}$	Cell 5 (Y_{12})
13	$+C_2 \times X_{13}$	$+C_3 \times X_{13}$	$+C_4 \times X_{13}$	$+C_5 \times X_{13}$	$+C_6 \times X_{13}$	$C_7 \times X_{13}$	$+C_0 \times X_{13}$	$+C_1 \times X_{13}$	Cell 6 (Y_{13})
14	$+C_1 \times X_{14}$	$+C_2 \times X_{14}$	$+C_3 \times X_{14}$	$+C_4 \times X_{14}$	$+C_5 \times X_{14}$	$+C_6 \times X_{14}$	$+C_7 \times X_{14}$	$+C_0 \times X_{14}$	Cell 7 (Y_{14})
15	$+C_0 \times X_{15}$	$+C_1 \times X_{15}$	$+C_2 \times X_{15}$	$+C_3 \times X_{15}$	$+C_4 \times X_{15}$	$+C_5 \times X_{15}$	$+C_6 \times X_{15}$	$C_7 \times X_{15}$	Cell 0 (Y_{15})

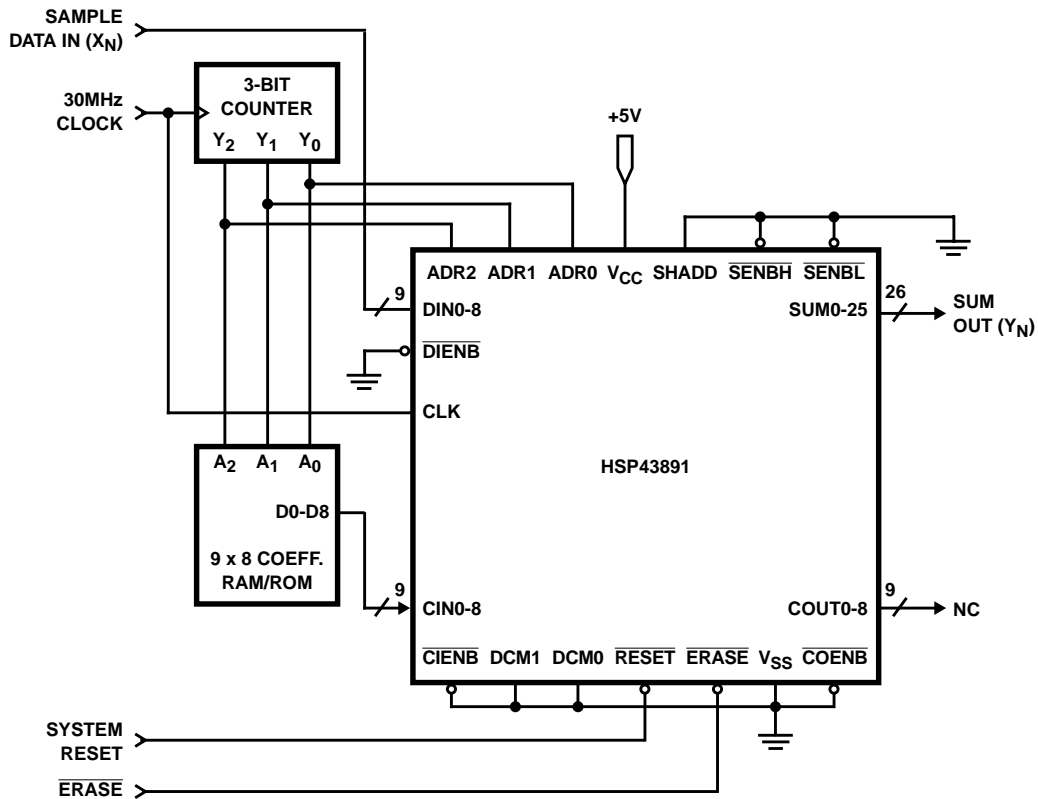

FIGURE 3. HSP43891 30MHz, 8-TAP FIR FILTER APPLICATION SCHEMATIC

Detailed operation of the DF to perform a basic 8-tap, 9-bit coefficient, 9-bit data, 30MHz FIR filter is best understood by observing the schematic (Figure 3) and timing diagram (Figure 4). The internal pipeline length of the DF is four (4) clock cycles, corresponding to the register levels CREG (or XREG), MREG0, MREG1, and TREG (Figures 1 and 2). Therefore, the delay from presentation of data and coefficients at the DIN0-8 and CIN0-8 inputs to a sum appearing at the SUM0-25 output is: $k + T_d$, where k = filter

length and $T_d = 4$, the internal pipeline delay of the DF. After the pipeline has filled, a new output sample is available every clock. The delay to last sample output from last sample input is T_d . The output sums, Y_N , shown in the timing diagram are derived from the sum-of-products equation.

$$Y_N = \sum_{K=0}^7 C_K X_{N-K}$$

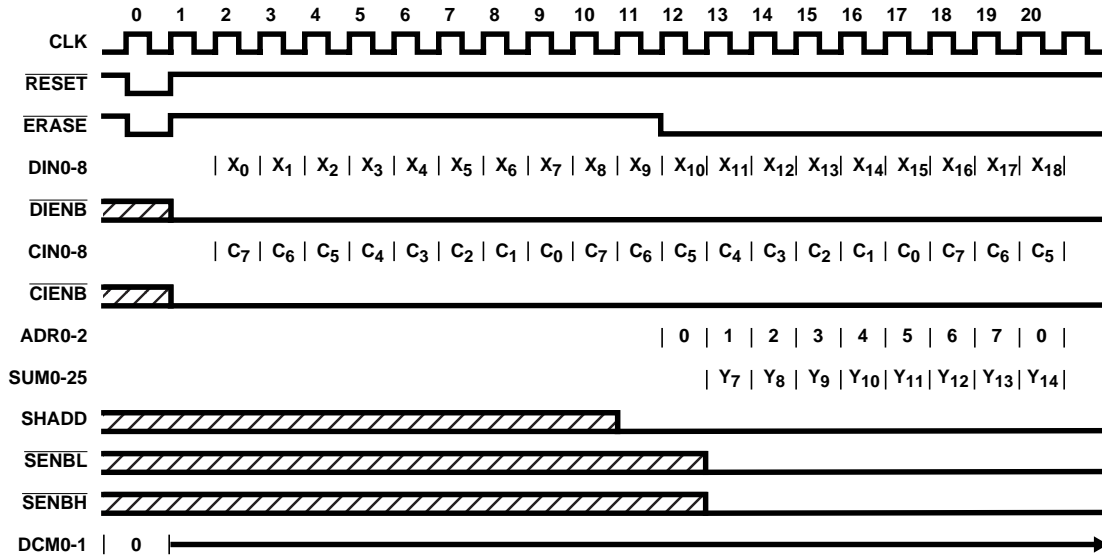

FIGURE 4. HSP43891 30MHz, 8-TAP FIR FILTER TIMING

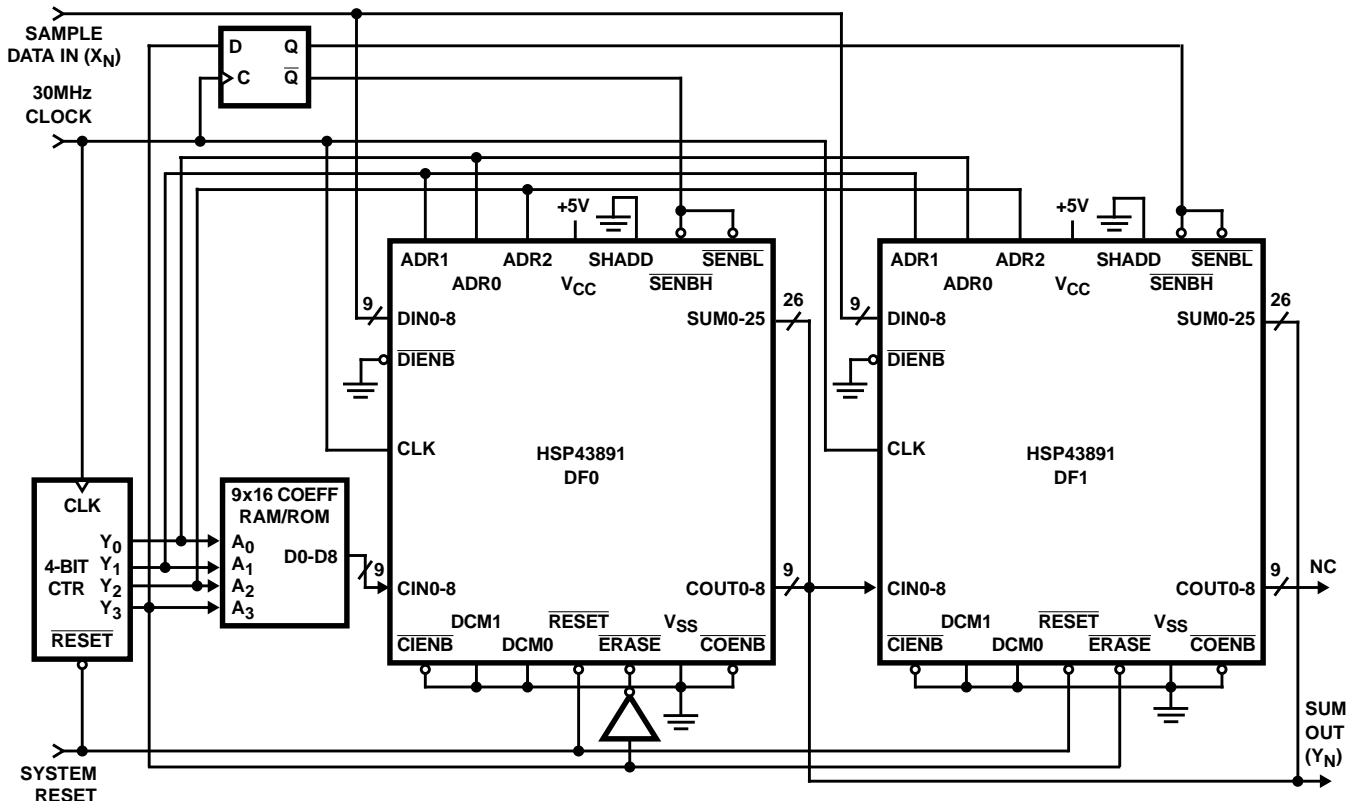

FIGURE 5. HSP43891 30MHz, 16-TAP FIR FILTER CASCADE APPLICATION SCHEMATIC

Extended FIR Filter Length Filter

lengths greater than eight taps can be created by either cascading together multiple DF devices or “reusing” a single device. Using multiple devices, an FIR filter of over 1000 taps can be constructed to operate at a 30MHz sample rate. Using a single device clocked at 30MHz, an FIR filter of over 500 taps can be constructed to operate at less than a 30MHz sample rate. Combinations of these two techniques are also possible.

Cascade Configuration

To design a filter length $L > 8$, $L/8$ DFs are cascaded by connecting the COUT0-8 outputs of the (i)th DF to the CIN0-8 inputs of the (i+1)th DF. The DIN0-8fs inputs and SUM0-25 outputs of all the DFs are also tied together. A specific example of two cascaded DFs illustrates the technique (Figure 5). Timing (Figure 6) is similar to the simple 8-tap FIR, except the $\overline{\text{ERASE}}$ and $\overline{\text{SENBL}}/\overline{\text{SENBH}}$ signals must be enabled independently for the two DFs in order to clear the correct accumulators and enable the SUM0-25 output signals at the proper times.

TABLE 2.

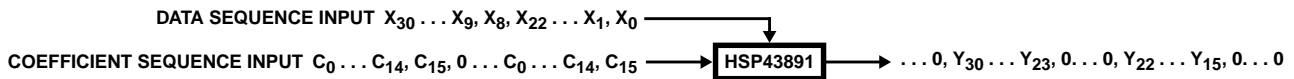

CLK	CELL 0	CELL 1	CELL 2	CELL 3	CELL 4	CELL 5	CELL 6	CELL 7	SUM/CLR
6	$C_{15} \times X_0$	0	0	0	-	-	-	-	-
7	$+C_{14} \times X_1$	$C_{15} \times X_1$	0	0	-	-	-	-	-
8	$+C_{13} \times X_2$		$C_{15} \times X_2$	0	-	-	-	-	-
9	$+C_{12} \times X_3$			$C_{15} \times X_3$	-	-	-	-	-
10	$+C_{11} \times X_4$			$+C_{14} \times X_4$	$C_{15} \times X_4$	-	-	-	-
11	$+C_{10} \times X_5$			$+C_{13} \times X_5$		$C_{15} \times X_5$	-	-	-
12	$+C_9 \times X_6$			$+C_{12} \times X_6$			$C_{15} \times X_6$	-	-
13	$+C_8 \times X_7$			$+C_{11} \times X_7$				$C_{15} \times X_7$	-
14	$+C_7 \times X_8$			$+C_{10} \times X_8$				$+C_{14} \times X_8$	-
15	$+C_6 \times X_9$			$+C_9 \times X_9$				$+C_{13} \times X_9$	-
16	$+C_5 \times X_{10}$			$+C_8 \times X_{10}$				$+C_{12} \times X_{10}$	-
17	$+C_4 \times X_{11}$			$+C_7 \times X_{11}$				$+C_{11} \times X_{11}$	-
18	$+C_3 \times X_{12}$			$+C_6 \times X_{12}$				$+C_{10} \times X_{12}$	-
19	$+C_2 \times X_{13}$			$+C_5 \times X_{13}$				$+C_9 \times X_{13}$	-
20	$+C_1 \times X_{14}$			$+C_4 \times X_{14}$				$+C_8 \times X_{14}$	-
21	$+C_0 \times X_{15}$			$+C_3 \times X_{15}$				$+C_7 \times X_{15}$	Cell 0 (Y ₁₅)
22	0	$C_0 \times X_{16}$		$+C_2 \times X_{16}$				$+C_6 \times X_{16}$	Cell 1 (Y ₁₆)
23	0	0	$C_0 \times X_{17}$	$+C_1 \times X_{17}$				$+C_5 \times X_{17}$	Cell 2 (Y ₁₇)
24	0	0	0	$+C_0 \times X_{18}$				$+C_4 \times X_{18}$	Cell 3 (Y ₁₈)
25	0	0	0	0	$C_0 \times X_{19}$			$+C_3 \times X_{19}$	Cell 4 (Y ₁₉)
26	0	0	0	0	0	$C_0 \times X_{20}$		$+C_2 \times X_{20}$	Cell 5 (Y ₂₀)
27	0	0	0	0	0	0	$C_0 \times X_{21}$	$+C_1 \times X_{21}$	Cell 6 (Y ₂₁)
28	0	0	0	0	0	0	0	$+C_0 \times X_{22}$	Cell 7 (Y ₂₂)
29	$C_{15} \times X_8$	0	0	0	0	0	0	0	-
30	$+C_{14} \times X_9$	$+C_{15} \times X_9$	0	0	0	0	0	0	-
31	$+C_{13} \times X_{10}$		$+C_{15} \times X_{10}$	0	0	0	0	0	-
32	$+C_{12} \times X_{11}$			$+C_{15} \times X_{11}$	0	0	0	0	-
33	$+C_{11} \times X_{12}$				$+C_{15} \times X_{12}$	0	0	0	-
34	$+C_{10} \times X_{13}$					$+C_{15} \times X_{12}$	0	0	-
35	$+C_9 \times X_{14}$						$+C_{15} \times X_{14}$	0	-
36	$+C_8 \times X_{15}$							$C_{15} \times X_{15}$	-
37	$+C_7 \times X_{16}$							$+C_{14} \times X_{16}$	-
38	$+C_6 \times X_{17}$							$+C_{13} \times X_{17}$	-
39	$+C_5 \times X_{18}$							$+C_{12} \times X_{18}$	-
40	$+C_4 \times X_{19}$							$+C_{11} \times X_{19}$	-
41	$+C_3 \times X_{20}$							$+C_{10} \times X_{20}$	-
42	$+C_2 \times X_{21}$							$+C_9 \times X_{21}$	-
43	$+C_1 \times X_{22}$							$+C_8 \times X_{22}$	-
44	$+C_0 \times X_{23}$							$+C_7 \times X_{23}$	Cell 0 (Y ₂₃)
45	0	$C_0 \times X_{23}$						$+C_6 \times X_{24}$	Cell 1 (Y ₂₄)
46	0	0	$C_0 \times X_{25}$					$+C_5 \times X_{25}$	Cell 2 (Y ₂₅)
47	0	0	0	$C_0 \times X_{26}$				$+C_4 \times X_{26}$	Cell 3 (Y ₂₆)
48	0	0	0	0	$C_0 \times X_{27}$			$+C_3 \times X_{27}$	Cell 4 (Y ₂₇)

Single DF Configuration

Using a single DF, a filter of length $L > 8$ can be constructed by processing in $L/8$ passes, as illustrated in Table 2, for a 16-tap FIR. Each pass is composed of $T_p = 7 + L$ cycles and computes eight output samples. In pass i , the sample with indices $i \cdot 8$ to $i \cdot 8 + (L - 1)$ enter the DIN0-8 inputs. The coefficients $C_0 - C_{L - 1}$ enter the CIN0-8 inputs, followed by seven zeros. As these zeros are entered, the result samples are output and the accumulators reset. Initial filling of the pipeline is not shown in this sequence table. Filter outputs can be put through a FIFO to even out the sample rate.

Extended Coefficient and Data Sample Word Size

The sample and coefficient word size can be extended by utilizing several DFs in parallel to get the maximum sample rate or a single DF with resulting lower sample rates. The technique is to compute partial products of 9×9 and combine these partial products by shifting and adding to obtain the final result. The shifting and adding can be accomplished with external adders (at full speed) or with the DF's shift-and-add mechanism contained in its output stage (at reduced speed).

Decimation/Resampling

The HSP43891 DF provides a mechanism for decimating by factors of 2, 3, or 4. From the DF filter cell block diagram (Figure 1), note the three D registers and two multiplexers in the coefficient path through the cell. These allow the coefficients to be delayed by 1, 2, or 3 clocks through the cell. The sequence table (Table 3) for a decimate-by-two filter illustrates the technique (internal cell pipelining ignored for simplicity). Detailed timing for a 30MHz input sample rate, 15MHz output sample rate (i.e., decimate-by-two), 16-tap FIR filter, including pipelining, is shown in Figure 7. This filter requires only a single HSP43891 DF.

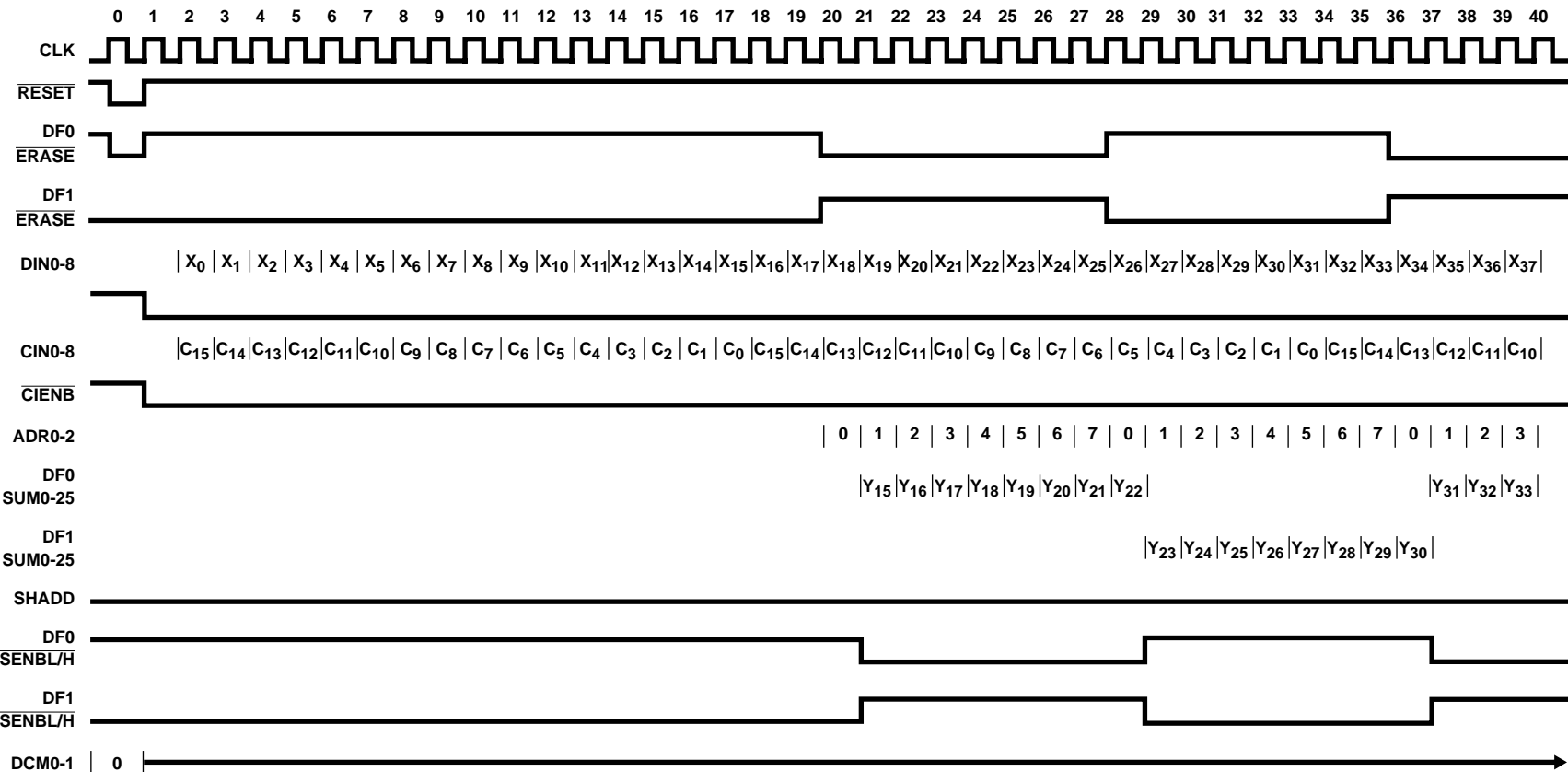

$$Y_N = \sum_{K=0}^{15} C_K X_{N-K}$$

FIGURE 6. HSP43891 16-TAP 30MHz FILTER TIMING USING TWO CASCADED HSP43891s

HSP43891

TABLE 3. HSP43891 16-TAP DECIMATE-BY-TWO FIR FILTER SEQUENCE; 30MHz IN, 15MHz OUT

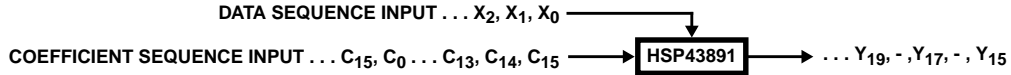

CLK	CELL 0	CELL 1	CELL 2	CELL 3	CELL 4	CELL 5	CELL 6	CELL 7	SUM/CLR
6	$C_{15} \times X_0$	0	0	0	0	0	0	0	-
7	$+C_{14} \times X_1$	0	0	0	0	0	0	0	-
8	$+C_{13} \times X_2$	$C_{15} \times X_2$	0	0	0	0	0	0	-
9	$+C_{12} \times X_3$	$+C_{14} \times X_3$	0	0	0	0	0	0	-
10	$+C_{11} \times X_4$	$+C_{13} \times X_4$	$C_{15} \times X_4$	0	0	0	0	0	-
11	$+C_{10} \times X_5$	$+C_{12} \times X_5$	$+C_{14} \times X_5$	0	0	0	0	0	-
12	$+C_9 \times X_6$	$+C_{11} \times X_6$	$+C_{13} \times X_6$	$C_{15} \times X_6$	0	0	0	0	-
13	$+C_8 \times X_7$	$+C_{10} \times X_7$	$+C_{12} \times X_7$	$+C_{14} \times X_7$	0	0	0	0	-
14	$+C_7 \times X_8$	$+C_9 \times X_8$	$+C_{11} \times X_8$	$+C_{13} \times X_8$	$C_{15} \times X_8$	0	0	0	-
15	$+C_6 \times X_9$	$+C_8 \times X_9$	$+C_{10} \times X_9$	$+C_{12} \times X_9$	$+C_{14} \times X_9$	0	0	0	-
16	$+C_5 \times X_{10}$	$+C_7 \times X_{10}$	$+C_9 \times X_{10}$	$+C_{11} \times X_{10}$	$+C_{13} \times X_{10}$	$C_{15} \times X_{10}$	0	0	-
17	$+C_4 \times X_{11}$	$+C_6 \times X_{11}$	$+C_8 \times X_{11}$	$+C_{10} \times X_{11}$	$+C_{12} \times X_{11}$	$+C_{14} \times X_{11}$	0	0	-
18	$+C_3 \times X_{12}$	$+C_5 \times X_{12}$	$+C_7 \times X_{12}$	$+C_9 \times X_{12}$	$+C_{11} \times X_{12}$	$+C_{13} \times X_{12}$	$C_{15} \times X_{12}$	0	-
19	$+C_2 \times X_{13}$	$+C_4 \times X_{13}$	$+C_6 \times X_{13}$	$+C_8 \times X_{13}$	$+C_{10} \times X_{13}$	$+C_{12} \times X_{13}$	$+C_{14} \times X_{13}$	0	-
20	$+C_1 \times X_{14}$	$+C_3 \times X_{14}$	$+C_5 \times X_{14}$	$+C_7 \times X_{14}$	$+C_9 \times X_{14}$	$+C_{11} \times X_{14}$	$+C_{13} \times X_{14}$	$C_{15} \times X_{14}$	-
21	$+C_0 \times X_{15}$	$+C_2 \times X_{15}$	$+C_4 \times X_{15}$	$+C_6 \times X_{15}$	$+C_8 \times X_{15}$	$+C_{10} \times X_{15}$	$+C_{12} \times X_{15}$	$+C_{14} \times X_{15}$	Cell0 (Y ₁₅)
22	$C_{15} \times X_{16}$	$+C_1 \times X_{16}$	$+C_3 \times X_{16}$	$+C_5 \times X_{16}$	$+C_7 \times X_{16}$	$+C_9 \times X_{16}$	$+C_{11} \times X_{16}$	$+C_{13} \times X_{16}$	-
23	$+C_{14} \times X_{17}$	$+C_0 \times X_{17}$	$+C_2 \times X_{17}$	$+C_4 \times X_{17}$	$+C_6 \times X_{17}$	$+C_8 \times X_{17}$	$+C_{10} \times X_{17}$	$+C_{12} \times X_{17}$	Cell1 (Y ₁₇)
24	$+C_{13} \times X_{18}$	$C_{15} \times X_{18}$	$+C_1 \times X_{18}$	$+C_3 \times X_{18}$	$+C_5 \times X_{18}$	$+C_7 \times X_{18}$	$+C_9 \times X_{18}$	$+C_{11} \times X_{18}$	-
25	$+C_{12} \times X_{19}$	$+C_{14} \times X_{19}$	$+C_0 \times X_{19}$	$+C_2 \times X_{19}$	$+C_4 \times X_{19}$	$+C_6 \times X_{19}$	$+C_8 \times X_{19}$	$+C_{10} \times X_{19}$	Cell2 (Y ₁₉)
26	$+C_{11} \times X_{20}$	$+C_{13} \times X_{20}$	$C_{15} \times X_{20}$	$+C_1 \times X_{20}$	$+C_3 \times X_{20}$	$+C_5 \times X_{20}$	$+C_7 \times X_{20}$	$+C_9 \times X_{20}$	-
27	$+C_{10} \times X_{21}$	$+C_{12} \times X_{21}$	$+C_{14} \times X_{21}$	$+C_0 \times X_{21}$	$+C_2 \times X_{21}$	$+C_4 \times X_{21}$	$+C_6 \times X_{21}$	$+C_8 \times X_{21}$	Cell3 (Y ₂₁)
28	$+C_9 \times X_{22}$	$+C_{11} \times X_{22}$	$+C_{13} \times X_{22}$	$C_{15} \times X_{22}$	$+C_1 \times X_{22}$	$+C_3 \times X_{22}$	$+C_5 \times X_{22}$	$+C_7 \times X_{22}$	-
29	$+C_8 \times X_{23}$	$+C_{10} \times X_{23}$	$+C_{12} \times X_{23}$	$+C_{14} \times X_{23}$	$+C_0 \times X_{23}$	$+C_2 \times X_{23}$	$+C_4 \times X_{23}$	$+C_6 \times X_{23}$	Cell4 (Y ₂₃)
30	$+C_7 \times X_{24}$	$+C_9 \times X_{24}$	$+C_{11} \times X_{24}$	$+C_{13} \times X_{24}$	$+C_{15} \times X_{24}$	$+C_1 \times X_{24}$	$+C_3 \times X_{24}$	$+C_5 \times X_{24}$	-
31	$+C_6 \times X_{25}$	$+C_8 \times X_{25}$	$+C_{10} \times X_{25}$	$+C_{12} \times X_{25}$	$+C_{14} \times X_{25}$	$+C_0 \times X_{25}$	$+C_2 \times X_{25}$	$+C_4 \times X_{25}$	Cell5 (Y ₂₅)
32	$+C_5 \times X_{26}$	$+C_7 \times X_{26}$	$+C_9 \times X_{26}$	$+C_{11} \times X_{26}$	$+C_{13} \times X_{26}$	$+C_{15} \times X_{26}$	$+C_1 \times X_{26}$	$+C_3 \times X_{26}$	-
33	$+C_4 \times X_{27}$	$+C_6 \times X_{27}$	$+C_8 \times X_{27}$	$+C_{10} \times X_{27}$	$+C_{12} \times X_{27}$	$+C_{14} \times X_{27}$	$+C_0 \times X_{27}$	$+C_2 \times X_{27}$	Cell6 (Y ₂₇)
34	$+C_3 \times X_{28}$	$+C_5 \times X_{28}$	$+C_7 \times X_{28}$	$+C_9 \times X_{28}$	$+C_{11} \times X_{28}$	$+C_{13} \times X_{28}$	$+C_{15} \times X_{28}$	$+C_1 \times X_{28}$	-
35	$+C_2 \times X_{29}$	$+C_4 \times X_{29}$	$+C_6 \times X_{29}$	$+C_8 \times X_{29}$	$+C_{10} \times X_{29}$	$+C_{12} \times X_{29}$	$+C_{14} \times X_{29}$	$+C_0 \times X_{29}$	Cell7 (Y ₂₉)
36	$+C_1 \times X_{30}$	$+C_3 \times X_{30}$	$+C_5 \times X_{30}$	$+C_7 \times X_{30}$	$+C_9 \times X_{30}$	$+C_{11} \times X_{30}$	$+C_{13} \times X_{30}$	$C_{15} \times X_{30}$	-
37	$+C_0 \times X_{31}$	$+C_2 \times X_{31}$	$+C_4 \times X_{31}$	$+C_6 \times X_{31}$	$+C_8 \times X_{31}$	$+C_{10} \times X_{31}$	$+C_{12} \times X_{31}$	$+C_{14} \times X_{31}$	Cell8 (Y ₃₁)

Absolute Maximum Ratings

Maximum Supply Voltage	+8.0V
Input, Output Voltage	GND -0.5V to V _{CC} +0.5V
Maximum Storage Temperature.....	-65°C to 150°C
ESD	Class 1
Junction Temperature	
PLCC	150°C
CPGA	175°C
Maximum Lead Temperature (Soldering 10s)	300°C

Operating Conditions

Voltage Range	5V ±5
Temperature Range	0°C to 70°C

Thermal Information

Thermal Resistance (Typical, Note 1)	θ_{JA} (°C/W)	θ_{JC} (°C/W)
MQFP Package	47	N/A
PLCC Package.....	37	N/A
CPGA Package	34.66	7.78
Typical Package Power Dissipation at 70°C		
MQFP Package	1.7W	
PLCC Package.....	2.2W	
CPGA Package	2.88W	
Gate Count	17763	
(PLCC MQFP Lead Tips Only)		

CAUTION: Stresses above those listed in "Absolute Maximum Ratings" may cause permanent damage to the device. This is a stress only rating and operation of the device at these or any other conditions above those indicated in the operational sections of this specification is not implied.

NOTE:

1. θ_{JA} is measured with the component mounted on an evaluation PC board in free air.

DC Electrical Specifications

PARAMETER		SYMBOL	TEST CONDITIONS	MIN	MAX	UNITS
Power Supply Current		I _{CCOP}	V _{CC} = Max, CLK Frequency 20MHz (Notes 2, 4)	-	140	mA
Standby Power Supply Current		I _{CCSB}	V _{CC} = Max (Note 4)	-	500	µA
Input Leakage Current		I _I	V _{CC} = Max, Input = 0V or V _{CC}	-10	10	µA
Output Leakage Current		I _O	V _{CC} = Max, Input = 0V or V _{CC}	-10	10	µA
Logical One Input Voltage		V _{IH}	V _{CC} = Max	2.0	-	V
Logical Zero Input Voltage		V _{IL}	V _{CC} = Min	-	0.8	V
Logical One Output Voltage		V _{OH}	I _{OH} = -400µA, V _{CC} = Min	2.6	-	V
Logical Zero Output Voltage		V _{OL}	I _{OL} = 2mA, V _{CC} = Min	-	0.4	V
Clock Input High		V _{IHC}	V _{CC} = Max	3.0	-	V
Clock Input Low		V _{ILC}	V _{CC} = Min	-	0.8	V
Input Capacitance	PLCC	C _{IN}	CLK Frequency 1MHz All measurements referenced to GND, T _A = 25°C (Note 3)	-	10	pF
	CPGA			-	15	pF
Output Capacitance	PLCC	C _{OUT}		-	10	pF
	CPGA			-	15	pF

NOTES:

2. Operating supply current is proportional to frequency. Typical rating is 7mA/MHz.
3. Controlled via design or process parameters and not directly tested. Characterized upon initial design and after major process and/or design changes.
4. Output load per test load circuit and C_L = 40pF.

AC Electrical Specifications $V_{CC} = 5V, \pm 5\%, T_A = 0^\circ C \text{ to } 70^\circ C$

PARAMETER	SYMBOL	TEST CONDITIONS	-20 (20MHz)		-25 (25.6MHz)		-30 (30MHz)		UNITS
			MIN	MAX	MIN	MAX	MIN	MAX	
Clock Period	t_{CP}		50	-	39	-	33	-	ns
Clock Low	t_{CL}		20	-	16	-	13	-	ns
Clock High	t_{CH}		20	-	16	-	13	-	ns
Input Setup	t_{IS}		16	-	14	-	13	-	ns
Input Hold	t_{IH}		0	-	0	-	0	-	ns
CLK to Coefficient Output Delay	t_{ODC}		-	24	-	20	-	18	ns
Output Enable Delay	t_{OED}		-	20	-	15	-	15	ns
Output Disable Delay	t_{ODD}	Note 5	-	20	-	15	-	15	ns
CLK to SUM Output Delay	t_{ODS}		-	27	-	25	-	21	ns
Output Rise	t_{OR}	Note 5	-	6	-	6	-	6	ns
Output Fall	t_{OF}	Note 5	-	6	-	6	-	6	ns

NOTE:

- Controlled by design or process parameters and not directly tested. Characterized upon initial design and after major process and/or design changes.

Test Load Circuit

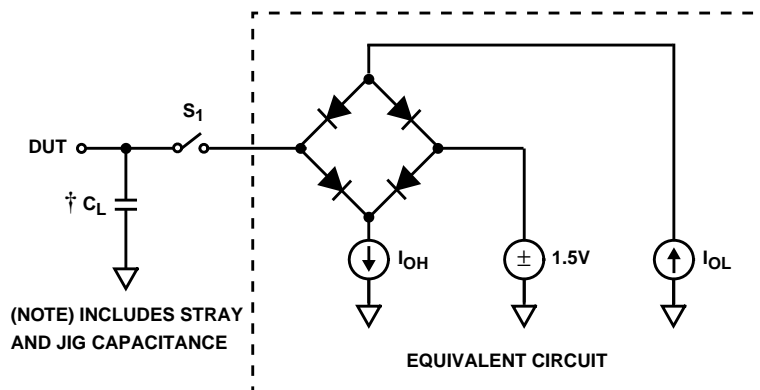

NOTE: Switch S_1 Open for I_{CCSB} and I_{CCOP} Tests.

Waveforms

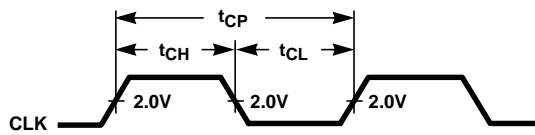
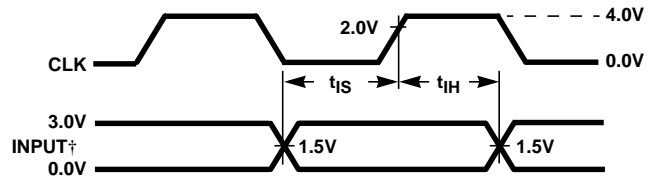

FIGURE 8. CLOCK AC PARAMETERS



NOTE: Input includes: DIN0-7, CIN0-7, DIENB, CIENB, ERASE, RESET, DCM0-1, ADR0-1, TCS, TCCI, SHADD

FIGURE 9. INPUT SETUP AND HOLD

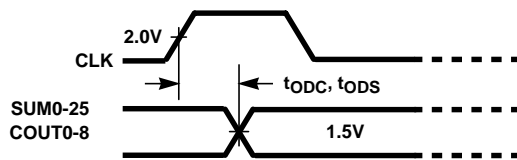

FIGURE 10. SUM0-25, COUT0-8, OUTPUT DELAYS

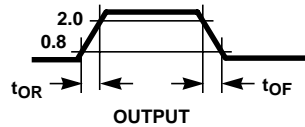

FIGURE 11. RISE AND FALL TIMES

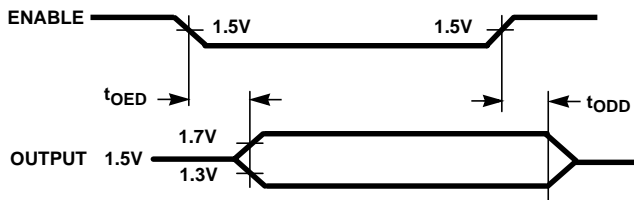
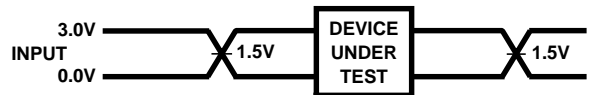

FIGURE 12. OUTPUT ENABLE, DISABLE TIMING



NOTE: AC Testing: Inputs are driven at 3.0V for a Logic "1" and 0.0V for a Logic "0". Input and output timing measurements are made at 1.5V for both a Logic "1" and "0". CLK is driven at 4.0V and 0V and measured at 2.0V.

FIGURE 13. AC TESTING INPUT, OUTPUT WAVEFORM

All Intersil semiconductor products are manufactured, assembled and tested under **ISO9000** quality systems certification.

Intersil semiconductor products are sold by description only. Intersil Corporation reserves the right to make changes in circuit design and/or specifications at any time without notice. Accordingly, the reader is cautioned to verify that data sheets are current before placing orders. Information furnished by Intersil is believed to be accurate and reliable. However, no responsibility is assumed by Intersil or its subsidiaries for its use; nor for any infringements of patents or other rights of third parties which may result from its use. No license is granted by implication or otherwise under any patent or patent rights of Intersil or its subsidiaries.

For information regarding Intersil Corporation and its products, see web site <http://www.intersil.com>

Sales Office Headquarters

NORTH AMERICA
Intersil Corporation
P. O. Box 883, Mail Stop 53-204
Melbourne, FL 32902
TEL: (407) 724-7000
FAX: (407) 724-7240

EUROPE
Intersil SA
Mercure Center
100, Rue de la Fusee
1130 Brussels, Belgium
TEL: (32) 2.724.2111
FAX: (32) 2.724.22.05

ASIA
Intersil (Taiwan) Ltd.
7F-6, No. 101 Fu Hsing North Road
Taipei, Taiwan
Republic of China
TEL: (886) 2 2716 9310
FAX: (886) 2 2715 3029

This datasheet has been downloaded from:

www.DatasheetCatalog.com

Datasheets for electronic components.



LittleDiode supplies new, hard to find or obsolete electronic components and semiconductors all over the world.

With over two million different components listed you are sure to find the part you need.

Feel free to visit us today at our online store:

LittleDiode.com

Looking forward to providing you with the best possible service.