

Binary Correlator

The Intersil HSP45256 is a high-speed, 256 tap binary correlator. It can be configured to perform one-dimensional or two-dimensional correlations of selectable data precision and length. Multiple HSP45256's can be cascaded for increased correlation length. Unused taps can be masked out for reduced correlation length.

The correlation array consists of eight 32-tap stages. These may be cascaded internally to compare 1, 2, 4 or 8-bit input data with a 1-bit reference. Depending on the number of bits in the input data, the length of the correlation can be up to 256, 128, 64, or 32 taps. The HSP45256 can also be configured as two separate correlators with window sizes from 4 by 32 to 1 by 128 each. The mask register can be used to prevent any subset of the 256 bits from contributing to the correlation score.

The output of the correlation array (correlation score) feeds the weight and sum logic, which gives added flexibility to the data format. In addition, an offset register is provided so that a preprogrammed value can be added to the correlation score. This result is then passed through a user programmable delay stage to the cascade summer. The delay stage simplifies the cascading of multiple correlators by compensating for the latency of previous correlators.

The Binary Correlator is configured by writing a set of control registers via a standard microprocessor interface. To simplify operation, both the control and reference registers are double buffered. This allows the user to load new mask and reference data while the current correlation is in progress.

Features

- Reconfigurable 256 Stage Binary Correlator
- 1-Bit Reference x 1, 2, 4, or 8-Bit Data
- Separate Control and Reference Interfaces
- 25.6, 33MHz Versions
- Configurable for 1-D and 2-D Operation
- Double Buffered Mask and Reference
- Programmable Output Delay
- Cascadable
- Standard Microprocessor Interface

Applications

- Radar/Sonar
- Spread Spectrum Communications
- Pattern/Character Recognition
 - Error Correction Coding

Ordering Information

PART NUMBER	TEMP. RANGE (°C)	PACKAGE	PKG. NO.
HSP45256JC-25	0 to 70	84 Ld PLCC	N84.1.15
HSP45256JC-33	0 to 70	84 Ld PLCC	N84.1.15
HSP45256GC-25	0 to 70	85 Ld PGA	G85.A
HSP45256GC-33	0 to 70	85 Ld PGA	G85.A
HSP45256JI-25	-40 to 85	84 Ld PLCC	N84.1.15
HSP45256JI-33	-40 to 85	84 Ld PLCC	N84.1.15

Block Diagram

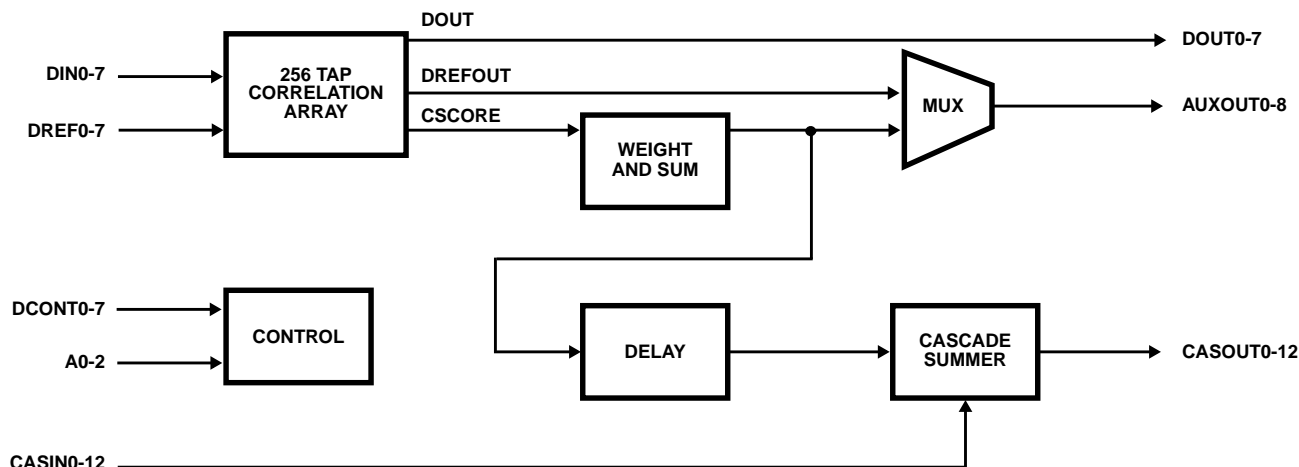

HSP45256

Pinouts

85 PIN PGA
BOTTOM VIEW

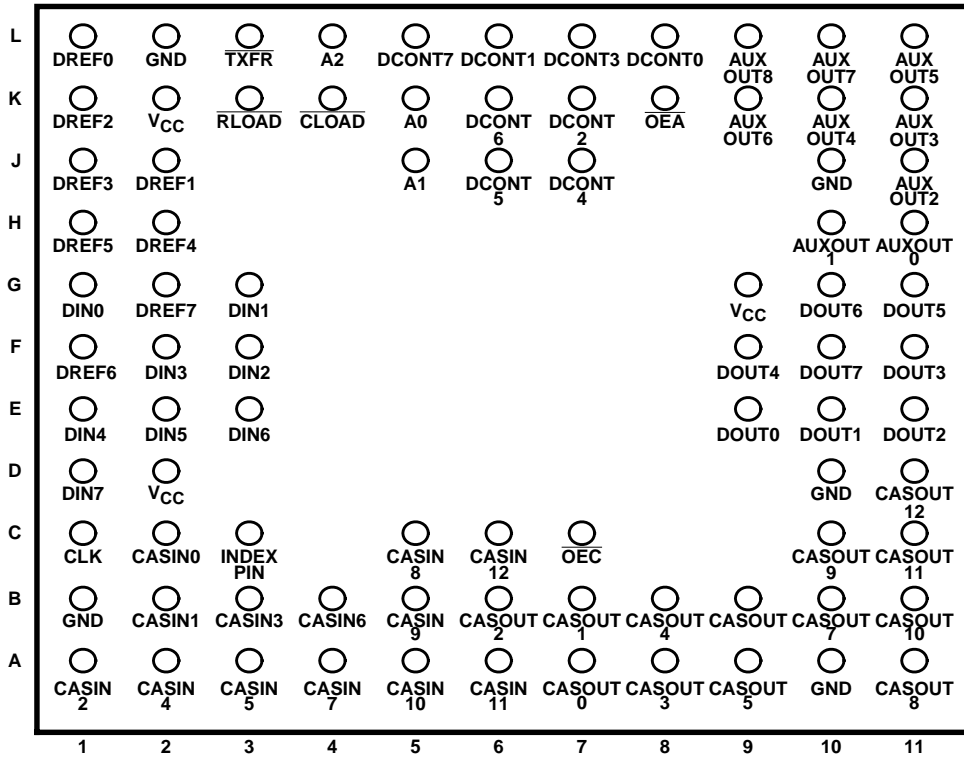

85 PIN PGA
TOP VIEW

	1	2	3	4	5	6	7	8	9	10	11
A	CASIN 2	CASIN 4	CASIN 5	CASIN 7	CASIN 10	CASIN 11	CAS OUT	CAS OUT3	CAS OUT5	GND	CAS OUT8
B	GND	CASIN 1	CASIN 3	CASIN 6	CASIN 9	CAS OUT2	CAS OUT1	CAS OUT4	CAS OUT6	CAS OUT7	CAS OUT10
C	CLK	CASIN 0	INDEX PIN		CASIN 8	CASIN 12	OEC			CAS OUT9	CAS OUT11
D	DIN7	V _{CC}								GND	CAS OUT12
E	DIN4	DIN5	DIN6						DOUT0	DOUT	DOUT2
F	DREF 6	DIN3	DIN2						DOUT 4	DOUT 7	DOUT 3
G	DIN0	DREF 7	DIN1						V _{CC}	DOUT 6	DOUT 5
H	DREF 5	DREF 4								AUX OUT1	AUX OUT0
J	DREF 3	DREF 1			A1	DCONT 5	DCONT 4			GND	AUX OUT2
K	DREF 2	V _{CC}	R LOAD	C LOAD	A0	DCONT 6	DCONT 2	OEA	AUX OUT6	AUX OUT4	AUX OUT3
L	DREF 0	GND	TXFR	A2	DCONT 7	DCONT 1	DCONT 3	DCONT 0	AUX OUT8	AUX OUT7	AUX OUT5

Pinouts (Continued)

84 PIN PLCC
TOP VIEW

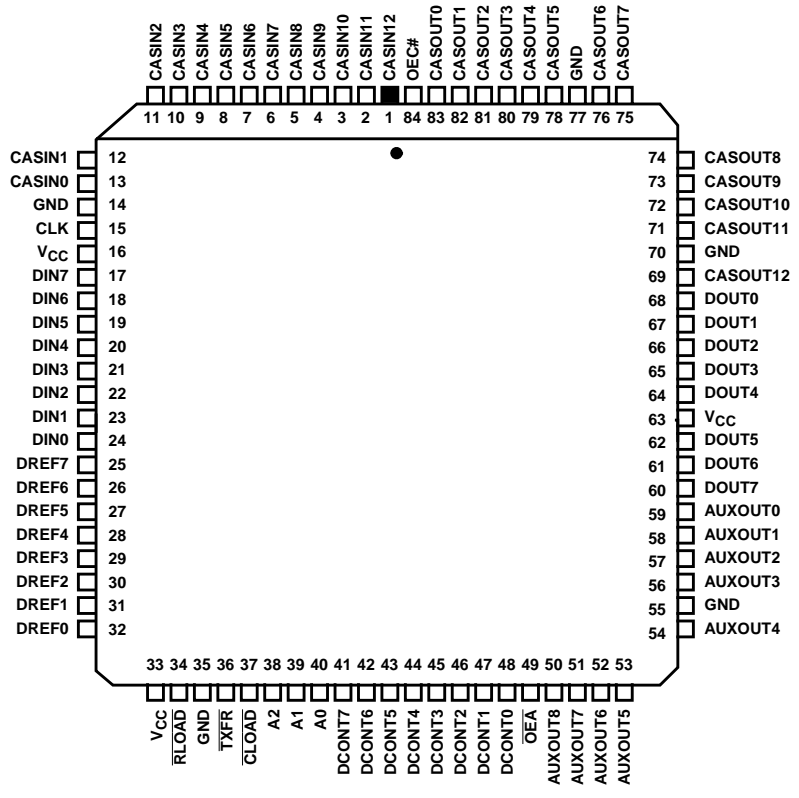

Pin Descriptions

SYMBOL	PLCC PIN NUMBER	TYPE	DESCRIPTION
V _{CC}	16, 33, 63		The +5V power supply pin.
GND	14, 35, 55, 70, 77		Ground.
DIN0-7	17-24	I	The DIN0-7 bus consists of eight single data input pins. The assignment of the active pins is determined by the configuration. Data is loaded synchronous to the rising edge of CLK. DIN0 is the LSB.
DOU0-7	60-62, 64-68	O	The DOU0-7 bus is the data output of the correlation array. The format of the output is dependent on the window configuration and bit weighting. DOU0 is the LSB.
CLK	15	I	System Clock. Positive edge triggered.
CASIN0-12	1-13	I	CASIN0-12 allows multiple correlators to be cascaded by connecting CASOUT0-12 of one correlator to CASIN0-12 of another. The CASIN bus is added internally to the correlation score to form CASOUT. CASIN0 is the LSB.
CASOUT0-12	69, 71-76, 78-83	O	CASOUT0-12 is the output correlation score. This value is the delayed sum of all the 256 taps of one chip and CASIN0-12. When the part is configured to act as two independent correlators, CASOUT0-8 represents the correlation score for the first correlator while the second correlation score is available on the AUXOUT0-8 bus. In this configuration, the cascading feature is no longer an option. CASOUT0 is the LSB.
\overline{OEC}	84	I	\overline{OEC} is the output enable for CASOUT0-12. When \overline{OEC} is high, the output is three-stated. Processing is not interrupted by this pin (active low).
\overline{TXFR}	36	I	\overline{TXFR} is a synchronous clock enable signal that allows the loading of the reference and mask inputs from the preload register to the correlation array. Data is transferred on the rising edge of CLK while \overline{TXFR} is low (active low).
DREF0-7	25-32	I	DREF0-7 is an 8-bit wide data reference input. This is the input data bus used to load the reference data. \overline{RLOAD} going active initiates the loading of the reference registers. This input bus is used to load the reference registers of the correlation array. The manner in which the reference data is loaded is determined by the window configuration. If the window configuration is 1 x 256, the reference bits are loaded one at a time over DREF7. When the HSP45256 is configured as an 8 x 32 array, the data is loaded into all stages in parallel. In this case, DREF7 is the reference data for the first stage and DREF0 is the reference data for the eighth stage. The contents of the reference data registers are not affected by changing the window configuration. DREF0 is the LSB.
\overline{RLOAD}	34	I	\overline{RLOAD} enables loading of the reference registers. Data on DREF0-7 is loaded into the preload registers on the rising edge of \overline{RLOAD} . This data is transferred into the correlation array by \overline{TXFR} (active low).
DCONT0-7	41-48	I	DCONT0-7 is the control data input which is used to load the mask bit for each tap, as well as the configuration registers. The mask data is sequentially loaded into the eight stages in the same manner as the reference data. DCONT0 is the LSB.
\overline{CLOAD}	37	I	\overline{CLOAD} enables the loading of the data on DCONT0-7. The destination of this data is controlled by A0-2 (active low).
A0-2	38-40	I	A0-2 is a 3-bit address that determines what function will be performed when \overline{CLOAD} is active. This address bus is set up with respect to the rising edge of the load signal, \overline{CLOAD} . A0 is the LSB.
AUXOUT0-8	50-54, 56-59	O	AUXOUT0-8 is a 9-bit bus that provides either the data reference output in the single correlation configuration or the 9-bit correlation score of the second correlator, in the dual correlator configuration. When the user programs the chip to be two separate correlators, the score of the second correlator is output on this bus. When the user has programmed the chip to be one correlator, AUXOUT0-7 represents the reference data out, with the state of AUXOUT8 undefined. AUXOUT0 is the LSB.
\overline{OEA}	49	I	The \overline{OEA} signal is the output enable for the AUXOUT0-8 output. When \overline{OEA} is high, the output is disabled. Processing is not interrupted by this pin (active low).

Block Diagram

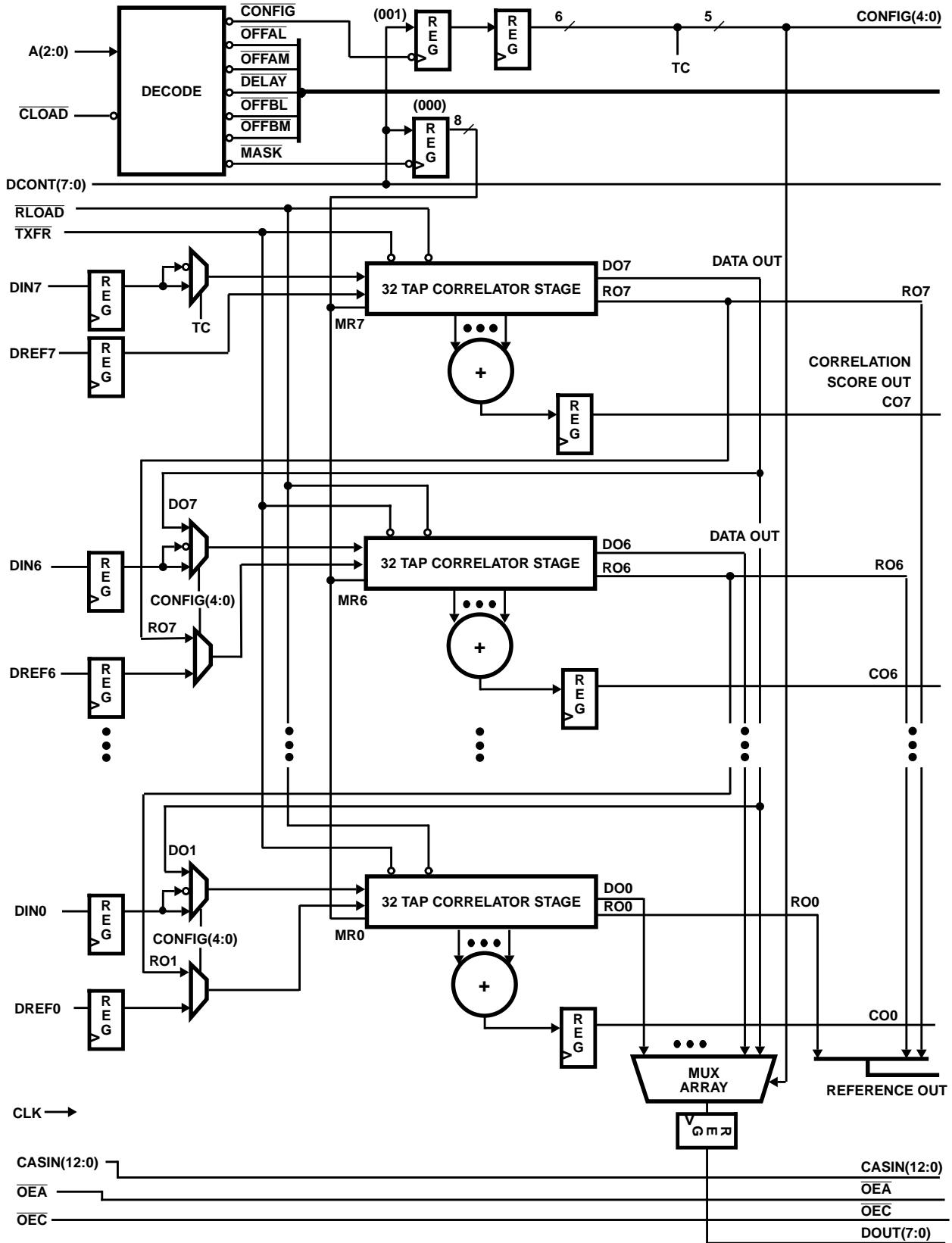

NOTE: All registers clocked with CLK unless otherwise specified.

CORRELATOR BLOCK DIAGRAM

Block Diagram (Continued)

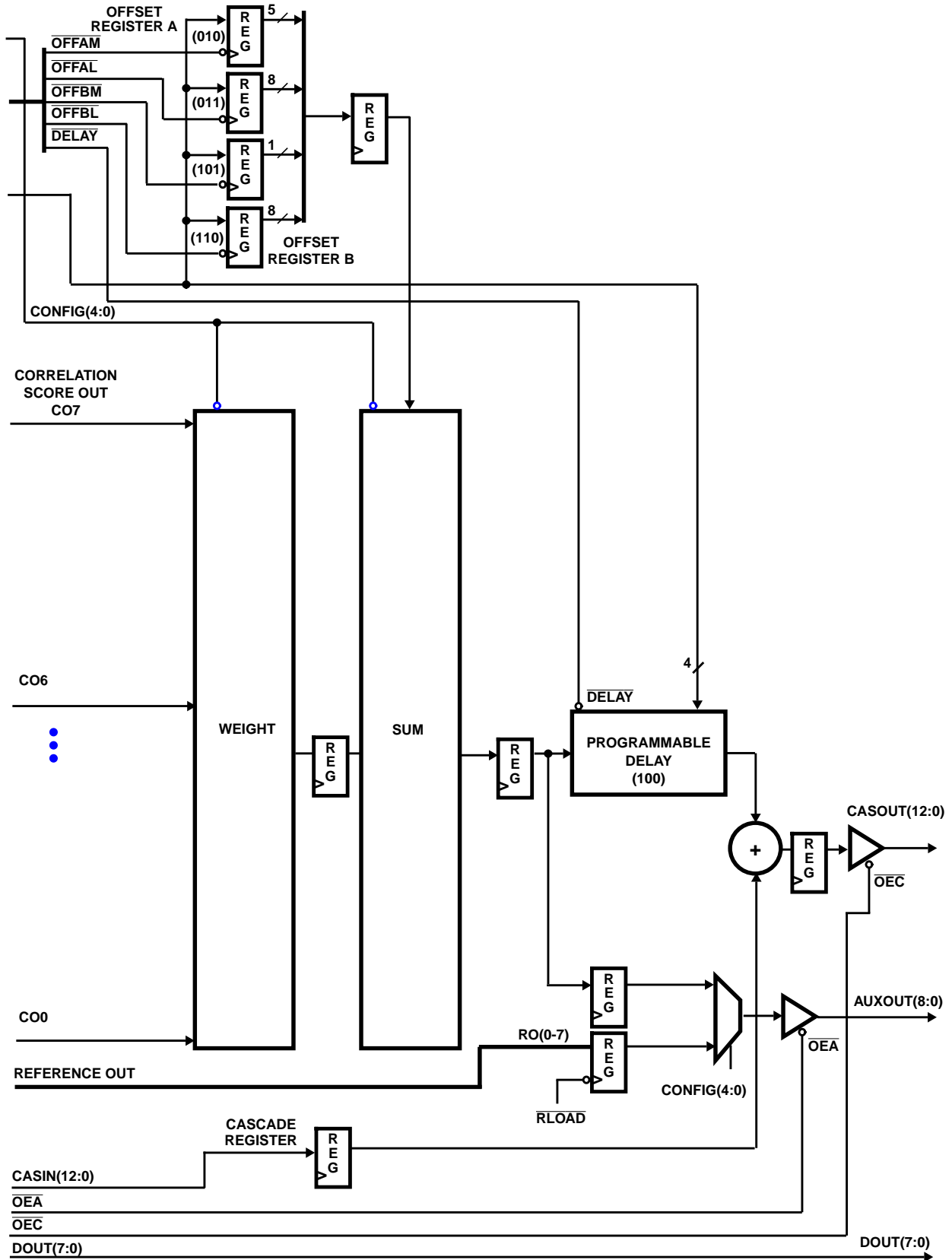

NOTE: All registers clocked with CLK unless otherwise specified.

Functional Description

The correlation array consists of eight 32-bit stages. The first stage receives data directly from input pin DIN7. The other seven stages receive input data from either an external data pin, DIN0-6, or from the Shift Register output of the previous stage, as determined by the Configuration Register. When the part is configured as a single correlator the sum of correlation score, Offset Register and cascade input appears on CASOUT0-12. Delayed versions of the data and reference inputs appear on DOUT0-7 and AUXOUT0-7, respectively. The input and output multiplexers of the correlation array are controlled together; for example, in a 1 x 256 correlation, the input data is loaded into DIN7 and the output appears on DOUT7. The configuration of the data bits, the length of the correlation (and in the two-dimensional data, the number of rows), is commonly called the correlation window. A top level Block Diagram of the single correlator configuration is shown in Figure 1. Compare the single correlator configuration data output and correlation output to the top level Block Diagram of the dual correlator configuration shown in Figure 2.

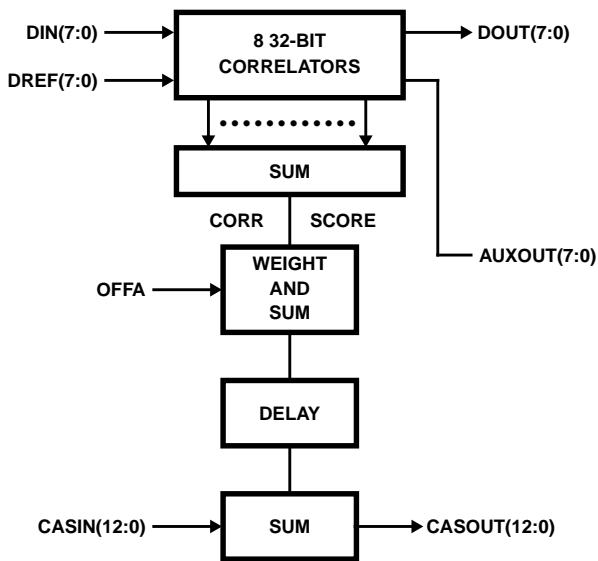

FIGURE 1. SINGLE CORRELATOR CONFIGURATION

Correlator Array

The core of the HSP45256 is the correlation array, which consists of eight 32-tap stages. A single correlator cell consists of an XNOR gate for the individual bit comparison; i.e., if the data and reference bits are either both high or both low, the output of the correlator cell is high. Figure 3 details the circuitry of a single correlation cell and Figure 4 shows the timing for that single correlation cell. In addition, two latches, one for the reference and one for the control data path are contained in this cell. These latches are loaded from the Preload Registers on the rising edge of CLK when TXFR is low so that the reference and mask values are updated without interrupting data processing.

The mask function is implemented with an AND gate. When a mask bit is a logic low, the corresponding correlator cell output is low.

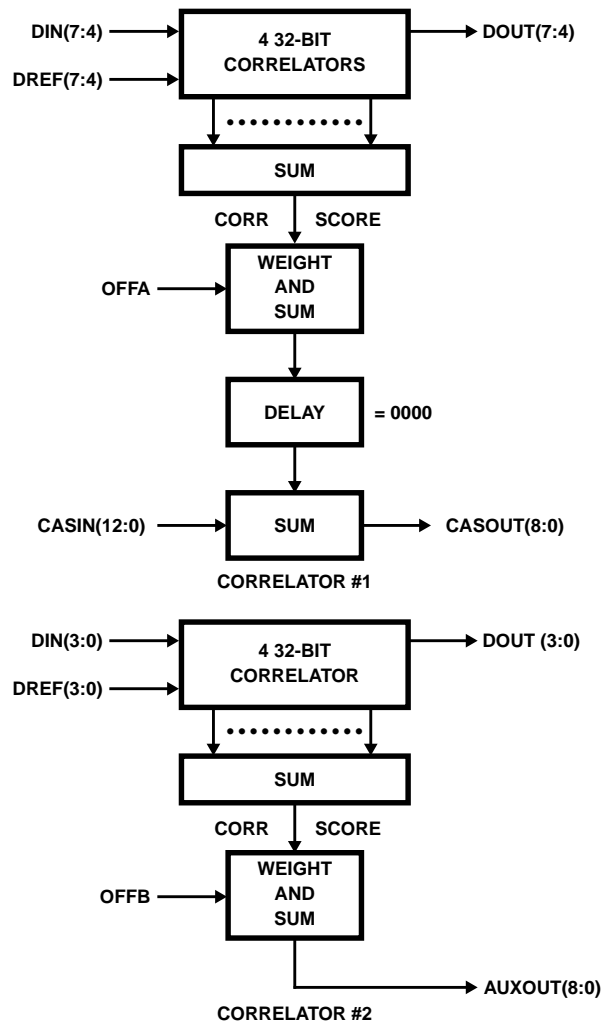

FIGURE 2. DUAL CORRELATOR CONFIGURATION

The function performed by one correlation cell is:

$$(D_{i,n} \text{ XNOR } R_{i,n}) \text{ AND } M_{i,n}$$

where:

$D_{i,n}$ = Bit i of data register n

$R_{i,n}$ = Bit i of reference register n

$M_{i,n}$ = Bit i of mask register n

The reference and mask bits are loaded sequentially, N bits at a time, where N depends on the current configuration (see Tables 2 and 9). New reference data is loaded on the rising edge of $\overline{\text{RLOAD}}$ and new mask data is loaded on the rising edge of $\overline{\text{CLOAD}}$.

The mask and reference bits are stored internally in Shift Registers, so that the mask and reference information that was loaded most recently will be used to process the newest data. When new information is loaded in, the previous contents of the mask and reference bits are shifted over by one sample, and the oldest information is lost. There are no registers in the multiplexer array (see Block Diagram), so the data on DOUT0-7 corresponds to the data in the last element of the correlation array. When monitoring DOUT0-7, AUXOUT0-8, and REFOUT0-7, only those bits listed in Table 9 are valid.

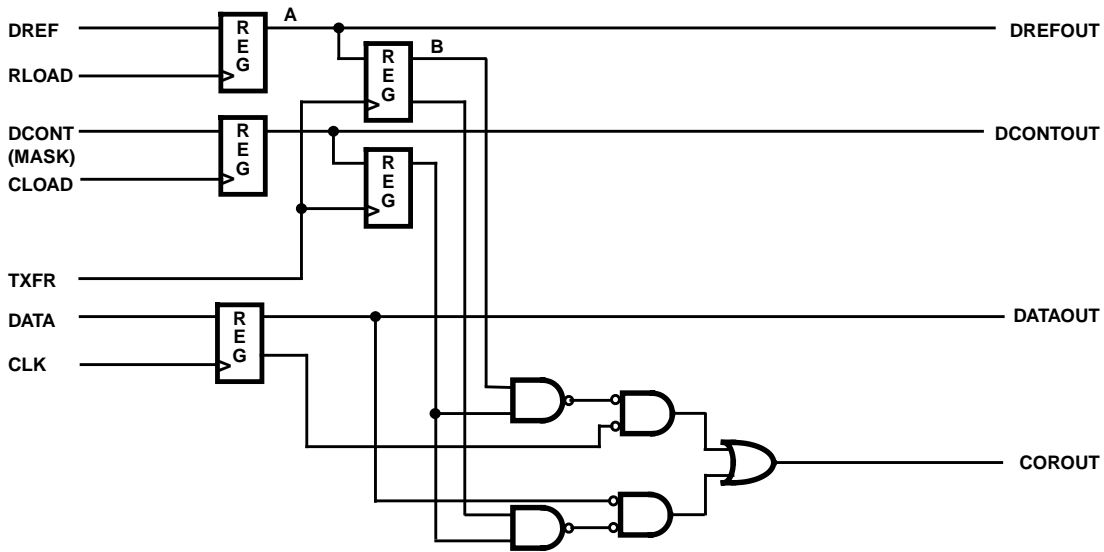

FIGURE 3. CORRELATION CELL BLOCK DIAGRAM

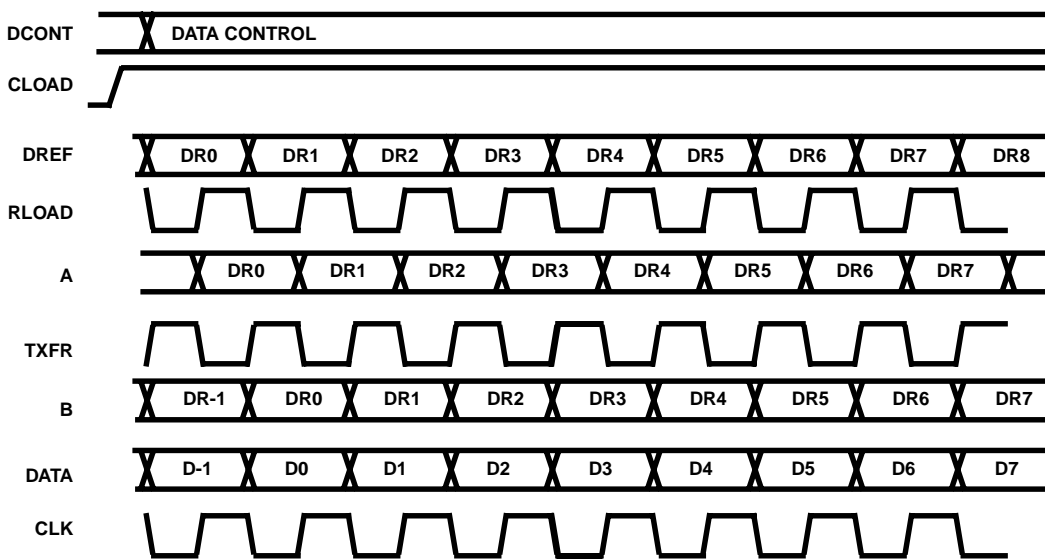

FIGURE 4. CORRELATION CELL TIMING DIAGRAM

Weight and Sum Logic

The Weight and Sum Logic provides the bit weighting and the final correlator score from the eight stages of the correlation array. For a 1 x 256 1-D configuration, the outputs of each of the stages are given a weight of 1 and then added together. In a 8 x 32 (8-bit data) configuration, the output of each stage will be shifted so that the output data represents an 8-bit word, with stage seven being the MSB.

The 13-bit Offset Register is loaded from the control data bus. Its output is added to the correlation score obtained from the correlator array. This sum then goes to the programmable delay register data input.

When the chip is configured as dual correlators, the user has the capability of loading two different offset values, one for each of the two correlators.

The Programmable Delay Register sets the number of pipeline stages between the output of the weight and sum logic and the input of the Cascade Summer. This delay register is used to align the correlation scores of multiple correlators in HSP45256 cascaded configurations (see Applications Section). The number of delays is programmable from 1 to 16, allowing for up to 16 correlators to be cascaded. When the HSP45256 is configured as dual correlators, the delay must be set to 0000, which specifies a delay of 1.

Cascade Summer

The Cascade Summer is used for cascading several correlator chips together. The value present on this bus represents the correlation score from the previous HSP45256 that will be summed with the current score to provide the final correlation score. When several correlator chips are cascaded, the CASOUT0-12 of each correlator is connected to the CASIN0-12 of the next correlator in the chain. The CASIN0-12 of the first chip is tied low. The following function represents the correlation score present on CASOUT0-12 of each correlator:

$$\text{CASOUT}(n) = (W7 \times \text{CO7})(n\text{-Delay}) + (W6 \times \text{CO6})(n\text{-Delay}) + (W5 \times \text{CO5})(n\text{-Delay}) + (W4 \times \text{CO4})(n\text{-Delay}) + (W3 \times \text{CO3})(n\text{-Delay}) + (W2 \times \text{CO2})(n\text{-Delay}) + (W1 \times \text{CO1})(n\text{-Delay}) + (W0 \times \text{CO0})(n\text{-Delay}) + \text{Offset}(n\text{-Delay}) + \text{CASIN}.$$

where:

CO0-CO7 are the correlation score outputs out of the correlation stages; W0-W7 is the weight given to each stage; n-Delay represents the delay on the weighted and summed correlation score through the Programmable Delay Register; Offset is the value programmed into the Offset register; CASIN is the cascade input.

Control Registers

The 3-bit address value, A0-2, is used to determine which internal register will be loaded with the data on DCONT0-7. The function is initiated when $\overline{\text{CLOAD}}$ is brought low, and the register is loaded on the rising edge of $\overline{\text{CLOAD}}$. Table 1 indicates the function associated with each address. Tables 2 - 8 define the function of the bits in each of the control registers.

TABLE 1. ADDRESS MAPPING

A2	A1	A0	DESTINATION
0	0	0	Mask Register
0	0	1	Configuration Register
0	1	0	Offset Register A-Most Significant Bits
0	1	1	Offset Register A-Least Significant Bits
1	0	0	Programmable Delay Register
1	0	1	Offset Register B-Most Significant Bits
1	1	0	Offset Register B-Least Significant Bits
1	1	1	Reserved

TABLE 2. MASK REGISTER

DESTINATION ADDRESS = 0 (000)		
BIT POSITIONS	FUNCTION	DESCRIPTION
7-0	Mask Register Bit Enable	MR(7:0): Mask Register. When mask register bit N = 1, the corresponding reference register bit is enabled. Mask register data is loaded from the DCONT(7:0) bus into a holding register on the rising edge of $\overline{\text{CLOAD}}$ and is written to the mask register on the rising edge of TXFR.

TABLE 3. CONFIGURATION REGISTER

DESTINATION ADDRESS = 1 (001)		
BIT POSITION	FUNCTION	DESCRIPTION
7-6	Reserved	Reserved; Program to zero.
5	TC	Configures correlator for twos complement input format, where the position of the MSB is depends on the current configuration. TC = 1 is twos complement; TC = 0 is offset binary.
4	CONFIG(4)	CONFIG4: The state of CONFIG4 configures the HSP45256 as either one or two correlators. When CONFIG4 = 0, the HSP45256 is configured as one correlator with the correlation score available on CASOUT0-12. When CONFIG4 = 1, the HSP45256 is configured as dual correlators with the first correlators score available on CASOUT0-8 and the second score available on AUXOUT0-8. When the chip is configured as dual correlators, the Programmable Delay must be set to 0000 for a delay of 1.
3-2	CONFIG(3:2):	CONFIG(3:2): Control the number of data bits to be correlated. See Table 9.
1-0	CONFIG(1:0)	CONFIG(1:0): CONFIG1 and CONFIG0 represent the length of the correlation window as indicated in Table 9.

TABLE 4. MS OFFSET REGISTER A

DESTINATION ADDRESS = 2 (010)		
BIT POSITION	FUNCTION	DESCRIPTION
7-5	Reserved	Reserved. Program to zero.
4-0	Offset Register A MSB	OFFA(12:8): Most significant bits of Offset Register A. This is the register used in single correlator mode.

TABLE 5. LS OFFSET REGISTER A

DESTINATION ADDRESS = 3 (011)		
BIT POSITION	FUNCTION	DESCRIPTION
7-0	Offset Register A LSB	OFFA(7:0): Least significant bits of Offset Register A.

TABLE 6. PROGRAMMABLE DELAY REGISTER

DESTINATION ADDRESS = 4 (100)		
BIT POSITION	FUNCTION	DESCRIPTION
7-4	Reserved	Reserved. Program to zero.
3-0	Programmable Delay	PDELAY(3:0): Controls amount of delay from the weight and sum logic to the cascade summer. The number of delays is 1-16, with PDELAY = 0000 corresponding to a delay of 1 and PDELAY = 1111 corresponding to a delay of 16.

TABLE 7. MS OFFSET REGISTER B

DESTINATION ADDRESS = 5 (101)		
BIT POSITION	FUNCTION	DESCRIPTION
7-1	Reserved	Reserved. Program to zero.
0	Offset Register B MSB	OFFB8: Most significant bit of Offset Register B. In dual correlator mode, this register is used for the correlator whose output appears on the AUXOUT pins.

TABLE 8. LS OFFSET REGISTER B

DESTINATION ADDRESS = 6 (110)		
BIT POSITION	FUNCTION	DESCRIPTION
7-0	Offset Register B LSB	OFFB0-7: Least significant bits of Offset Register B.

TABLE 9. CONFIGURATION SETUP

CONFIGURATION					NO. OF CORRELATORS	DATA BITS	ROWS	LENGTH	CORRELATOR	ACTIVE INPUTS		ACTIVE OUTPUTS			OUTPUT WEIGHTING									
4	3	2	1	0						DIN	DREF	DOUT	AUXOUT	CASOUT	CO7	CO6	CO5	CO4	CO3	CO2	CO1	CO0		
0	0	0	0	0	1	1	1	256	-	7	7	7	7	12-0	1	1	1	1	1	1	1	1	1	1
0	0	0	0	1	1	1	2	128	-	7, 3	7, 3	7, 3	7, 3	12-0	1	1	1	1	1	1	1	1	1	1
0	0	0	1	0	1	1	4	64	-	7, 5, 3, 1	7, 5, 3, 1	7, 5, 3, 1	7, 5, 3, 1	12-0	1	1	1	1	1	1	1	1	1	1
0	0	0	1	1	1	1	8	32	-	7-0	7-0	7-0	7-0	12-0	1	1	1	1	1	1	1	1	1	1
0	0	1	0	1	1	2	1	128	-	7, 3	7	7, 3	7, 3	12-0	2	2	2	2	1	1	1	1	1	1
0	0	1	1	0	1	2	2	64	-	7, 5, 3, 1	7, 5	7, 5, 3, 1	7, 5, 3, 1	12-0	2	2	2	2	1	1	1	1	1	1
0	0	1	1	1	1	2	4	32	-	7-0	7, 6, 5, 4	7-0	7-0	12-0	2	2	2	2	1	1	1	1	1	1
0	1	0	1	0	1	4	1	64	-	7, 5, 3, 1	7	7, 5, 3, 1	7, 5, 3, 1	12-0	8	8	2	2	4	4	1	1	1	1
0	1	0	1	1	1	4	2	32	-	7-0	7, 6	7-0	7-0	12-0	8	8	2	2	4	4	1	1	1	1
0	1	1	1	1	1	8	1	32	-	7-0	7	7-0	7-0	12-0	128	8	32	4	64	2	16	1	1	1
1	0	0	0	1	2	1	1	128	A B	7 3	7 3	7 3	- 8-0	12-0 -	1 -	1 -	1 -	1 -	- 1	- 1	- 1	- 1	- 1	- 1
1	0	0	1	0	2	1	2	64	A B	7, 5 3, 1	7, 5 3, 1	7, 5 3, 1	- 8-0	12-0 -	1 -	1 -	1 -	1 -	- 1	- 1	- 1	- 1	- 1	- 1
1	0	0	1	1	2	1	4	32	A B	7-4 3-0	7-4 3-0	7-4 3-0	- 8-0	12-0 -	1 -	1 -	1 -	1 -	- 1	- 1	- 1	- 1	- 1	- 1
1	0	1	1	0	2	2	1	64	A B	7, 5 3, 1	7 3	7, 5 3, 1	- 8-0	12-0 -	2 -	2 -	1 -	1 -	- 2	- 2	- 1	- 1	- 1	- 1
1	0	1	1	1	2	2	2	32	A B	7-4 3-0	7, 6 3, 2	7-4 3-0	- 8-0	12-0 -	2 -	2 -	1 -	1 -	- 2	- 2	- 1	- 1	- 1	- 1
1	1	0	1	1	2	4	1	32	A B	7-4 3-0	7 3	7-4 3-0	- 8-0	12-0 -	8 -	2 -	4 -	1 -	- 8	- 2	- 4	- 1	- 1	- 1

During reference register loading, the 8-bits, DREF0-7 are used as reference data inputs. The falling edge of $\overline{\text{RLOAD}}$ initiates reference data loading; when $\overline{\text{RLOAD}}$ returns high, the data on DREF0-7 is latched into the selected correlation stages. The active bits on DREF0-7 are determined by the current configuration.

The window configuration is determined by the state of control signals upon programming the Control Register. Table 9 represents the programming information required for each window configuration. In Table 9, note that the data listed for Output Weighting refers to the weights given to each of the Correlation Sum Outputs (CO0-7 in the Block Diagram).

During initialization, the loading configuration for the reference data is set by the user. Table 9 shows the loading options. These load controls specify whether the reference data for a given stage comes from the shift register output of the previous stage or from an external data pin.

Applications

There are 10 single correlator configurations possible with the HSP45256. There are six dual correlator configurations possible with the HSP45256. Table 10 details the configuration (bits x rows x length) and the maximum correlation sums of all combinations.

TABLE 10. CORRELATION SCORE FORMULAS FOR SINGLE CORRELATOR CONFIGURATIONS

FIGURE NUMBER	CONFIGURATION BITS x ROWS x LENGTH	HIGHEST POSSIBLE TOTAL CORRELATION SCORE	CORRELATION SCORE
Figure 5	1 x 1 x 256	256	$CS=CO7+CO6+CO5+CO4+CO3+CO2+CO1+CO0$
Figure 6	1 x 2 x 128	256	$CS=CO7+CO6+CO5+CO4+CO3+CO2+CO1+CO0$
Figure 7	1 x 4 x 64	256	$CS=CO7+CO6+CO5+CO4+CO3+CO2+CO1+CO0$
Figure 8	1 x 8 x 32	256	$CS=CO7+CO6+CO5+CO4+CO3+CO2+CO1+CO0$
Figure 9	2 x 1 x 128	384	$CS=2(CO7+CO6+CO5+CO4)+CO3+CO2+CO1+CO0$
Figure 10	2 x 2 x 64	384	$CS=2(CO7+CO6+CO5+CO4)+CO3+CO2+CO1+CO0$
Figure 11	2 x 4 x 32	384	$CS=2(CO7+CO6+CO5+CO4)+CO3+CO2+CO1+CO0$
Figure 12	4 x 1 x 64	960	$CS=8(CO7+CO6)+4(CO5+CO4)+2(CO3+CO2)+CO1+CO0$
Figure 13	4 x 2 x 32	960	$CS=8(CO7+CO6)+4(CO5+CO4)+2(CO3+CO2)+CO1+CO0$
Figure 14	8 x 1 x 32	8160	$CS=128CO7+64CO6+32CO5+16CO4+8CO3+4CO2+2CO1+CO0$
Figure 15	1 x 1 x 128 1 x 1 x 128	128	$CS=CO7+CO6+CO5+CO4CS=CO3CO2+CO1+CO0$
Figure 16	1 x 2 x 64 1 x 2 x 64	128	$CS=CO7+CO6+CO5+CO4CS=CO3CO2+CO1+CO0$
Figure 17	1 x 4 x 32 1 x 4 x 32	128	$CS=CO7+CO6+CO5+CORCS=CO3CO2+CO1+CO0$
Figure 18	2 x 1 x 64 2 x 1 x 64	192	$CS=2(CO7+CO6)+CO5+CO4CS=(CO3+CO2)+CO1+CO0$
Figure 19	2 x 2 x 32 2 x 2 x 32	192	$CS=2(CO7+CO6)+CO5+CO4CS=(CO3+CO2)+CO1+CO0$
Figure 20	4 x 1 x 32 4 x 1 x 32	480	$CS=8CO7+4CO6+2CO5+CO4CS=8CO3+4CO2+2CO1+CO0$

Single Correlator Configurations

1-Bit Data, Single Row, 256 Samples Configuration

A 1 x 256 (1-D configuration) correlation requires only 1 HSP45256. To initialize the correlator, all the reference bits, control bits, the delay value of the variable delay, and the window configuration must be specified. Table 11 details these settings for the 1-bit data, 256 Samples Configuration. Figure 5 illustrates the data flow through the correlator.

TABLE 11. REGISTER CONTENTS FOR 1 X 256 CORRELATOR WITH EQUAL WEIGHTING

A0-2	DCONT0-7	NOTES
001	00000000	1 256-tap correlator: 1 x 256 window configuration, reference loaded from DREF7, eight stages weighted equally, DIN 7 and DOUT7 are the data input and output, respectively.
010	000000f00	Offset Register A = 0.
011	00000000	
100	00000000	Programmable Delay = 0.
101	00000000	Offset Register B = 0 (Loading of this register optional in this mode).
110	00000000	

The loading of the Reference and Mask Registers may be done simultaneously by setting A0-2 = 000, setting the DREF and DCONT inputs to their proper values and pulsing RLOAD and CLOAD low. In this configuration, DREF7 loads the reference data and DCONT7 loads the mask information; both sets of data are loaded serially. It will take 256 load pulses (RLOAD) to load the reference array, and 256 CLOAD pulses to load the mask array. Upon completion of the mask and register loading, TXFR is pulsed low, which transfers the reference and control data from the preload registers to the Reference and Mask Registers, updating the data that will be used in the correlation. Reference and mask data can be loaded more quickly by configuring the correlator as an 8 row by 32 sample array, loading the bits eight at a time, then changing the configuration back to 1 x 256 to perform the correlation.

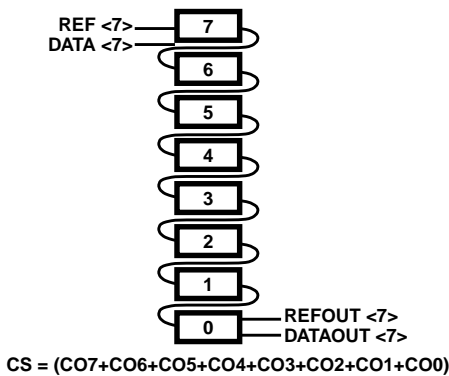

FIGURE 5. 1-BIT, 1 ROW OF 256 TAPS

Other 1-Bit Configurations

1-Bit, Dual Row, 128 Sample Configuration

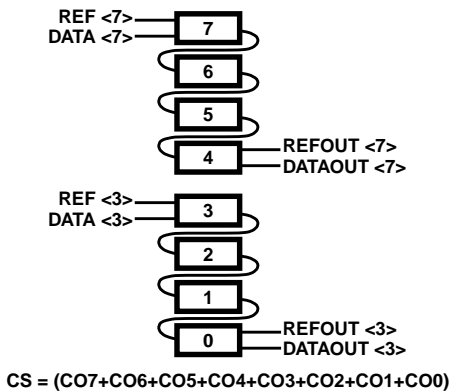

FIGURE 6. 1-BIT, 2 ROWS OF 128 TAPS

1-Bit, Quad Row, 64 Sample Configuration

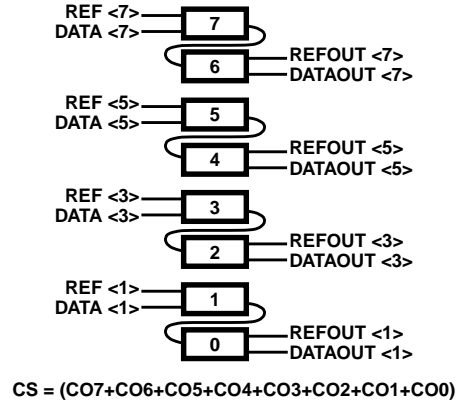

FIGURE 7. 1-BIT, 4 ROWS OF 64 TAPS

1-Bit, Octal Row, 32 Sample Configuration

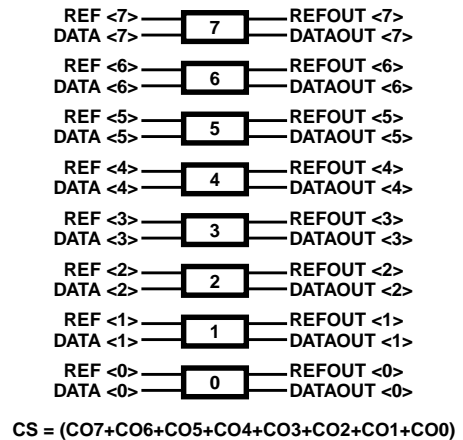

FIGURE 8. 1-BIT, 8 ROWS OF 32 TAPS

2-Bit Configurations

2-Bit, Single Row, 128 Sample Configuration

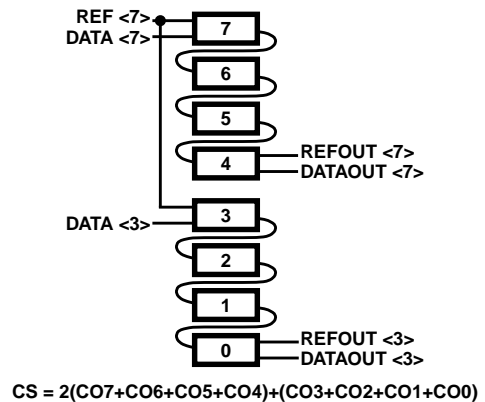

FIGURE 9. 2 BITS, 1 ROW OF 128 TAPS

2-Bit Data, Dual Row, 64 Samples

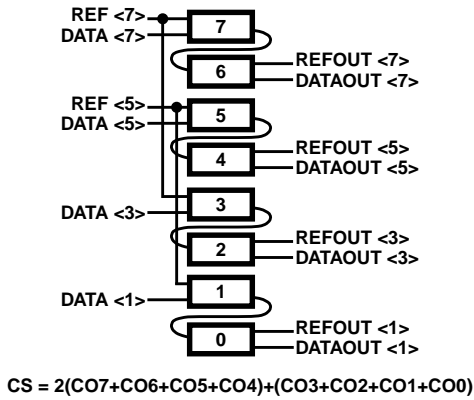

FIGURE 10. 2-BITS, 2 ROWS OF 64 TAPS

2-Bit, Quad Row, 32 Sample Configuration

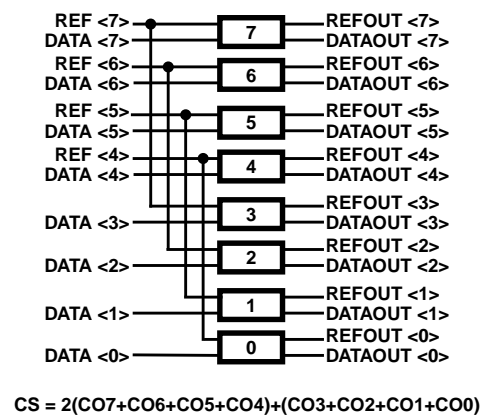

FIGURE 11. 2-BITS, 4 ROWS OF 32 TAPS

4-Bit Configurations

4-Bit, Single Row, 64 Sample Configuration

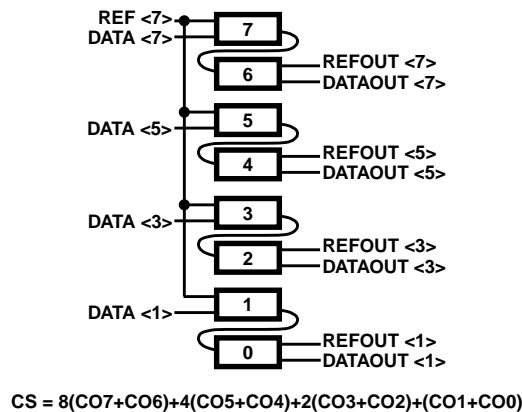

FIGURE 12. 4-BITS, 1 ROW OF 64 TAPS

4-Bit Dual Row, 32 Sample Configurations

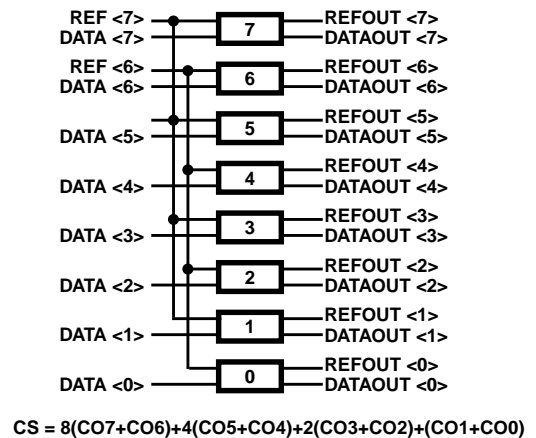

FIGURE 13. 4 BITS, 2 ROWS OF 32 TAPS

8-Bit Configurations

8-Bit Data, Single Row, 32 Sample Configurations

An 8 x 32 correlation also requires only 1 HSP45256. To initialize the correlator, all the reference bits, control bits, the value of the programmable delay, and the window configuration must be specified. Table 12 details these settings.

Again, the loading of the reference and mask registers can be done simultaneously. Due to the programming initialization, DREF0-7 are used to load the reference data 8-bits at a time. It will take 32 load pulses each of \overline{RLOAD} and \overline{CLOAD} to load both arrays. Upon completion of the mask and register loading, \overline{TXFR} is pulsed low, which transfers the reference and control data from the preload registers to the registers that store the active data.

This configuration performs correlation of an 8-bit number with a 1-bit reference. Each byte out of the correlation array gives an 8-bit level of confidence that the data corresponds to the reference. The correlation score is the sum of these confidence levels.

TABLE 12. REGISTER LOADING FOR 8 X 32 CORRELATOR WITH BINARY WEIGHTING

A0-2	DCONT0-7	NOTES
001	00001111	1 256-tap correlator; 8 x 32 window configuration, 8-bit data stream; reference register is loaded from DREF7 for all stages. Correlator score = (128 x CO7) + (64 x CO3) + (32 x CO5) + (16 x CO1) + (8 x CO6) + (4 x CO4) + (2 x CO2) + CO0.
010	00000000	Offset Register A = 0000000010000.
011	00010000	
100	00000000	Programmable Delay = 0.
101	00000000	Offset Register B = 0 (Loading optional in this mode).
110	00000000	

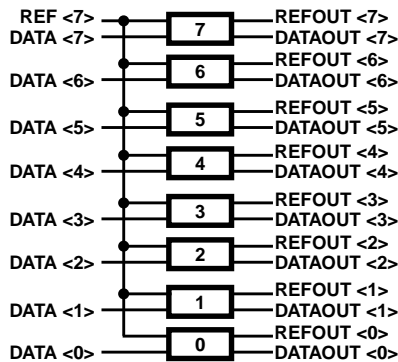

$$CS = 128CO7 + 64CO6 + 32CO5 + 16CO4 + 8CO3 + 4CO2 + 2CO1 + CO0$$

FIGURE 14. 8 BITS, 1 ROW OF 32 TAPS

Dual Correlator Configurations

1-Bit, Single Row, 128 Sample Configuration



FIGURE 15. DUAL 1-BIT, 1 ROW OF 128 TAPS

1-Bit, Dual Row, 64 Sample Configuration



FIGURE 16. 1-BIT, 2 ROWS OF 64 TAPS

1-Bit, Quad Row, 32 Sample Configuration



FIGURE 17. 1-BIT, 4 ROWS OF 32 TAPS

2-Bit, Dual Row, 64 Sample Configuration

Dual 2 x 64 correlators require only one HSP45256. To initialize the correlator, all the reference bits, control bits, the delay value of the variable delay, and the window configuration must be specified. Table 13 details the settings for the 2-bit Dual Row, 64 Sample Configuration.

In this example, each of the dual correlators compares 2-bit data to a 1-bit reference. It will take 64 load pulses (RLOAD/CLOAD) to completely load the reference and mask registers in the array. The programmable delay must be set to 0 for the output of the two correlators to be aligned.



FIGURE 18. 2-BITS, 1 ROW OF 64 TAPS

TABLE 13. REGISTER LOADING FOR DUAL 2 X 64 CORRELATORS WITH EQUAL WEIGHTING

AO-2	DCONT0-7	NOTES
001	00010110	Dual correlators: Each 2 bit data, 64 taps; reference register for correlation A is loaded from DREF7 and DREF5, the reference register for correlator B is loaded from DREF3 and DREF1. Correlator #1 = 2x CO7 + 2x CO6 + CO5 + CO4, correlator #2 = 2 x CO3 + 2x CO2 + CO1 + CO0.
010	00000000	Offset Register A = 0000000010000.
011	00010000	
100	00000000	Programmable Delay = 0.
101	00000000	Offset Register B = 0.
110	00000000	

2-Bit, Dual Row, 32 Sample Configuration

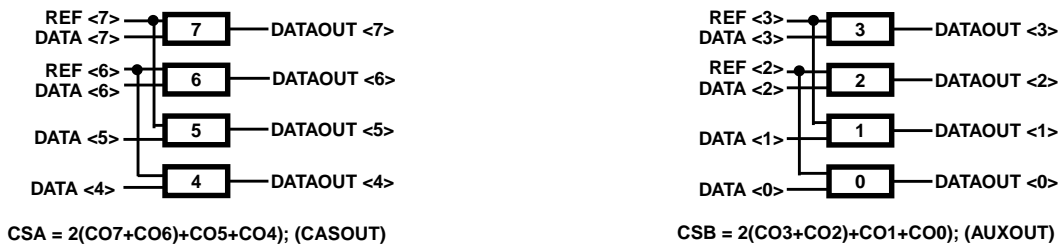

FIGURE 19. 2-BITS, 2 ROWS OF 32 TAPS

4-Bit, Single Row, 32 Sample Configuration

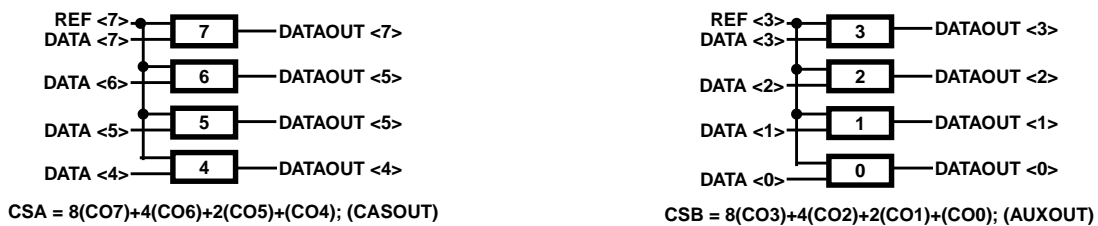

FIGURE 20. 4-BITS, 1 ROW OF 32 TAPS

Cascading Multiple Correlator Devices

Correlators can be cascaded in either a serial or parallel fashion. Longer correlations can be achieved by connecting several correlators together as shown in Figures 21- 23. In Figure 21, each correlator is in a one data bit, one row, 256 tap configuration. The number of bits of significance at the CASOUT output of each correlator builds up from one correlation to the next, that is, the maximum score out of the first correlator is 256, the maximum output of the second correlator is 512, etc. In this configuration, the maximum length of the correlation is 4096. This would be implemented with 16 HSP45256's. The Programmable Delay Register in the first correlator would be set for one delay, the second would be set for two, and so on, with the final HSP45256 being set for a delay of 16.

Correlations of more bits can be calculated by connecting CASOUT of each chip to the CASIN of the following chip

(Figure 21). The data on the CASOUT lines accumulates in a similar manner as in the 1 x 256 mode, except that the maximum output of the first correlator is decimal 960, (hexadecimal 3C0); in the general case, the maximum number of correlators that can be cascaded in this manner is eight, since the maximum output of the last one would be 1E00, which nearly uses up the 13-bit range of the cascade summer. More parts could be cascaded together if some bits are to be masked out or if the user has a prior knowledge of the maximum value of the correlation score. As before, the delay in the first correlator would be set to one, the second correlator would be set for a delay of two, and so on.

Multiple HSP45256's can be cascaded for two dimensional one bit data (Figure 22). The maximum output for each chip is the same as in the 1 x 256 case; the only difference is in the manner in which the correlators are connected. The programmable delay registers would be set as before.

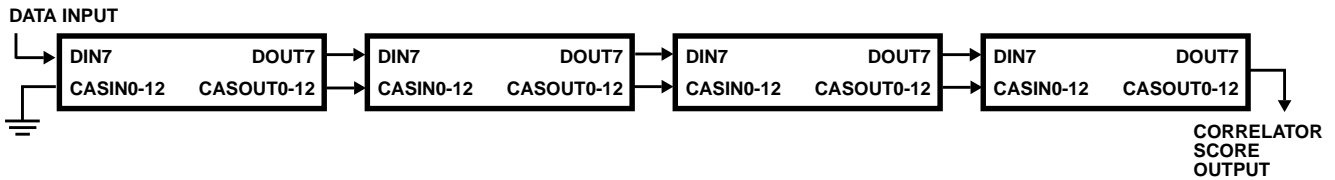

FIGURE 21. 1-BIT, 1024 SAMPLE CONFIGURATION

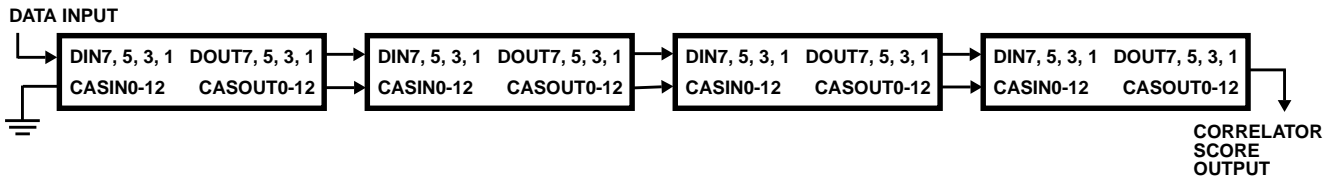

FIGURE 22. 4-BIT, 256 SAMPLE CONFIGURATION

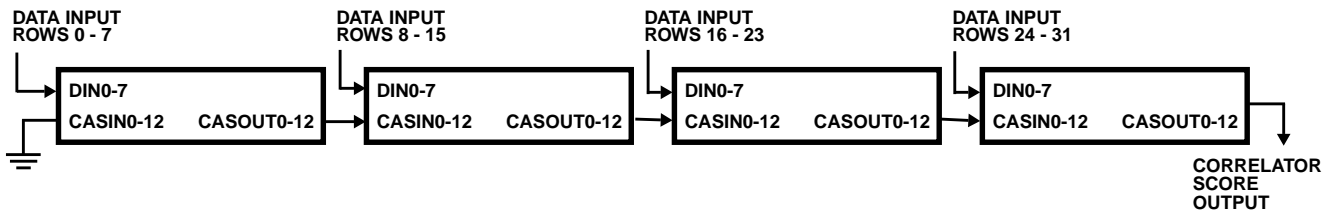

FIGURE 23. 1-BIT, 32 x 32 WINDOW CONFIGURATION

Reloading Data During Operation

$\overline{\text{RLOAD}}$ and $\overline{\text{CLOAD}}$ are asynchronous signals that are designed to be driven by the memory interface signals of a microprocessor. $\overline{\text{TXFR}}$ is synchronized to CLK so that the mask or reference data is updated on a specific clock cycle. In the normal mode of operation, the user loads the reference and mask memories, then pulses $\overline{\text{TXFR}}$ to use that data. The correlator uses the new mask or reference information immediately. Loading of the reference and mask data remains asynchronous as long as there is at least one cycle of CLK between the rising edge of $\overline{\text{RLOAD}}$ or $\overline{\text{CLOAD}}$ and the $\overline{\text{TXFR}}$ pulse.

If the system timing makes it necessary for $\overline{\text{TXFR}}$ and $\overline{\text{RLOAD}}$ and/or $\overline{\text{CLOAD}}$ to be active during the same clock cycle, then they must be treated as synchronous signals; the timing for this case is shown in Figure 24 and given in the AC Timing Specifications (t_{THCL} and t_{CLLH}). In this example, data is loaded during clock cycle 1 and transferred on the rising edge of CLK that occurs in clock cycle two. Another set of data is loaded during clock cycle 2, which will be

transferred by a later $\overline{\text{TXFR}}$ pulse. The sequence of events is as follows:

1. In clock cycle 1, $\overline{\text{TXFR}}$ becomes active at least t_{TH} nano-seconds after the rising edge of CLK.
2. $\overline{\text{RLOAD}}$ and/or $\overline{\text{CLOAD}}$ pulses low; the timing is not critical as long as its rising edge occurs before the end of clock cycle 1. If this condition is not met, it is undetermined whether the data loaded by this pulse will be transferred by the current $\overline{\text{TXFR}}$ pulse.
3. The rising edge of $\overline{\text{TXFR}}$ occurs while CLK is high during clock cycle 2. The margin between the rising edge of $\overline{\text{TXFR}}$ and the falling edge of CLK is defined by t_{THCL} .
4. $\overline{\text{RLOAD}}$ and/or $\overline{\text{CLOAD}}$ pulses low. The rising edge of $\overline{\text{RLOAD}}$ and $\overline{\text{CLOAD}}$ must occur after the falling edge of CLK. The margin between the two is defined by t_{CLLH} .

The time from the rising edge of $\overline{\text{TXFR}}$ to the falling edge of CLK must be greater than t_{THCL} , and the time from the falling edge of CLK to the rising edge of $\overline{\text{RLOAD}}$ or $\overline{\text{CLOAD}}$ must be greater than t_{CLLH} . If this timing is violated, the data being transferred by the $\overline{\text{TXFR}}$ pulse shown may or may not include the data loaded in clock cycle 2.

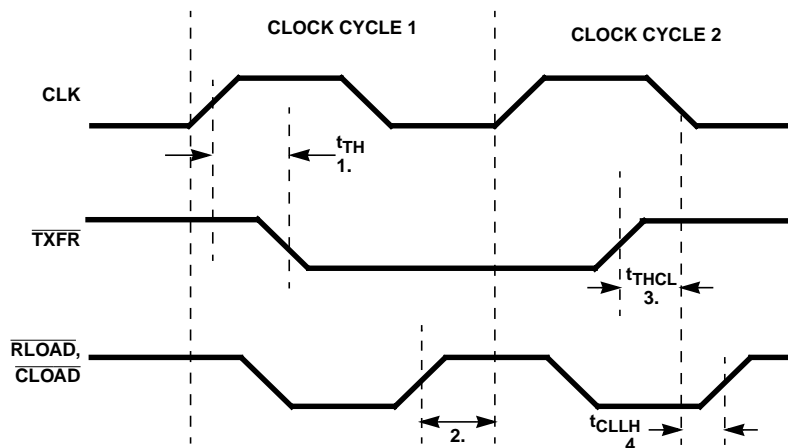

FIGURE 24. LOADING AND TRANSFERRING DATA DURING THE SAME CLOCK CYCLE

AC Electrical Specifications $V_{CC} = 5.0V \pm 5\%$, $T_A = 0^\circ C$ to $70^\circ C$, $T_A = -40^\circ C$ to $85^\circ C$, Note 5 (Continued)

PARAMETER	SYMBOL	NOTES	33MHz		25.6MHz		UNITS
			MIN	MAX	MIN	MAX	
Set-Up Time DIN to CLK High	t_{DS}		12	-	13	-	ns
Hold Time CLK High to DIN	t_{DH}		0	-	0	-	ns
\overline{TXFR} Set-Up Time	t_{TS}		12	-	13	-	ns
\overline{TXFR} Hold Time	t_{TH}		0	-	0	-	ns
Output Delay DOUT, AUXOUT, CASOUT	t_{DO}		-	15	-	20	ns
\overline{CLOAD} Cycle Time	t_{CLC}		30	-	39	-	ns
\overline{CLOAD} High	t_{CLH}		12	-	15	-	ns
\overline{CLOAD} Low	t_{CLL}		12	-	15	-	ns
Set-Up Time, A to \overline{RLOAD} , \overline{CLOAD}	t_{AS}		12	-	13	-	ns
Hold Time, \overline{RLOAD} , \overline{CLOAD} to A	t_{AH}		0	-	0	-	ns
\overline{RLOAD} Cycle Time	t_{RLC}		30	-	39	-	ns
\overline{RLOAD} High	t_{RLH}		12	-	15	-	ns
\overline{RLOAD} Low	t_{RLL}		12	-	15	-	ns
Set-Up Time, DCONT to \overline{CLOAD}	t_{DCS}		12	-	13	-	ns
Hold Time, \overline{CLOAD} to DCONT	t_{DCH}		0	-	0	-	ns
Set-Up Time, DREF to \overline{RLOAD}	t_{RS}		12	-	13	-	ns
Hold Time, \overline{RLOAD} to DREF	t_{RH}		0	-	0	-	ns
Output Enable Time	t_{OE}		-	15	-	15	ns
Output Disable Time	t_{OD}	Note 6	-	15	-	15	ns
Output Rise, Fall Time	t_{RF}	Note 6	-	6	-	6	ns
\overline{TXFR} High to CLK Low	t_{THCL}	Note 6	3	-	3	-	ns
CLK Low to \overline{RLOAD} , \overline{CLOAD} High	t_{CLLH}	Note 6	1	-	1	-	ns

NOTES:

- AC testing is performed as follows: Input levels (CLK Input) 4.0V and 0V; Input levels (all other inputs) 0V and 3.0V; Timing reference levels (CLK) 2.0V; All others 1.5V. Output load per test load circuit with $C_L = 40pF$. Output transition is measured at $V_{OH} > 1.5V$ and $V_{OL} < 1.5V$.
- Controlled via design or process parameters and not directly tested. Characterized upon initial design and after major process and/or design changes.

Test Load Circuit

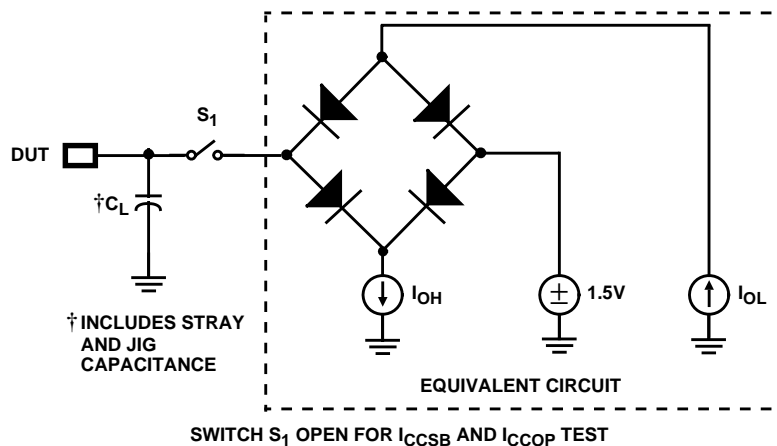

Timing Waveforms

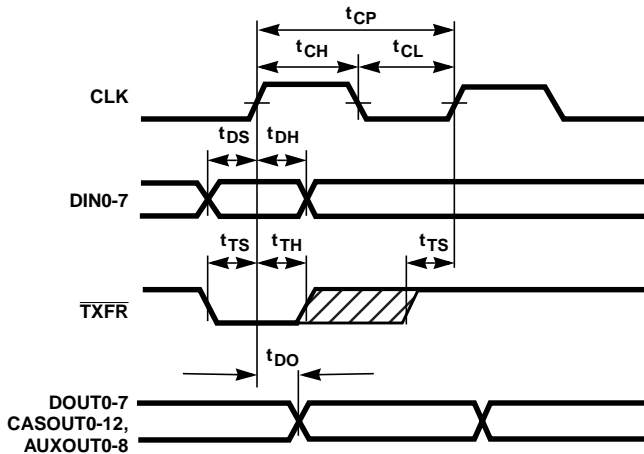

FIGURE 25. INPUT, OUTPUT TIMING

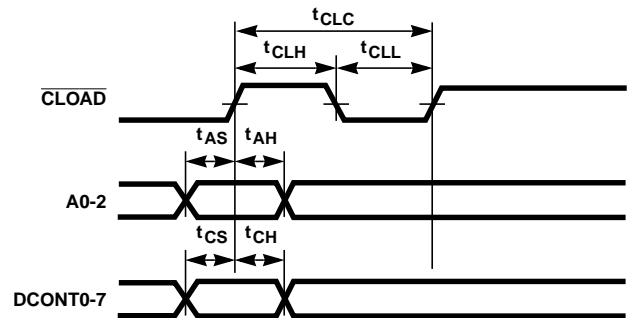

FIGURE 26. CONTROL INPUT TIMING

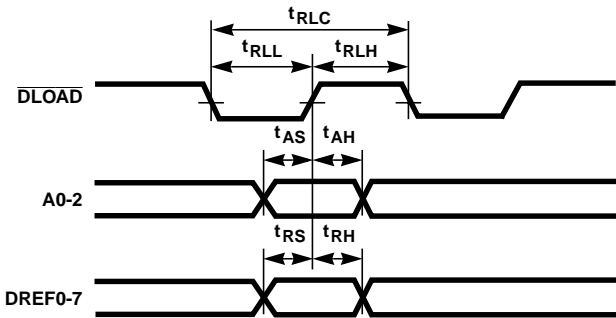

FIGURE 27. REFERENCE INPUT TIMING

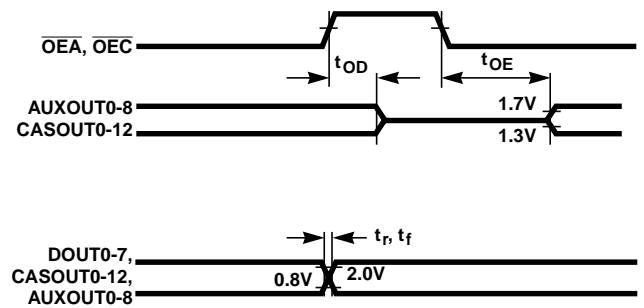

FIGURE 28. OUTPUT TIMING

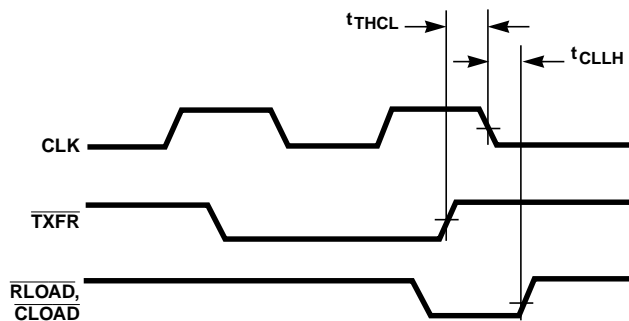

FIGURE 29. TRANSFER, LOAD TIMING WHEN BOTH OCCUR ON A SINGLE CYCLE

All Intersil semiconductor products are manufactured, assembled and tested under **ISO9000** quality systems certification.

Intersil semiconductor products are sold by description only. Intersil Corporation reserves the right to make changes in circuit design and/or specifications at any time without notice. Accordingly, the reader is cautioned to verify that data sheets are current before placing orders. Information furnished by Intersil is believed to be accurate and reliable. However, no responsibility is assumed by Intersil or its subsidiaries for its use; nor for any infringements of patents or other rights of third parties which may result from its use. No license is granted by implication or otherwise under any patent or patent rights of Intersil or its subsidiaries.

For information regarding Intersil Corporation and its products, see web site <http://www.intersil.com>

This datasheet has been downloaded from:

www.DatasheetCatalog.com

Datasheets for electronic components.



LittleDiode supplies new, hard to find or obsolete electronic components and semiconductors all over the world.

With over two million different components listed you are sure to find the part you need.

Feel free to visit us today at our online store:

LittleDiode.com

Looking forward to providing you with the best possible service.