

DATA SHEET

HSTL16918

9-bit to 18-bit HSTL-to-LVTTL
memory address latch

Product data

2001 Jun 16

9-bit to 18-bit HSTL-to-LVTTL memory address latch

HSTL16918

FEATURES

- Inputs meet JEDEC HSTL Std. JESD 8–6, and outputs meet Level III specifications
- ESD classification testing is done to JEDEC Standard JESD22. Protection exceeds 2000 V to HBM per method A114.
- Latch-up testing is done to JEDEC Standard JESD78, which exceeds 100 mA.
- Packaged in 48-pin plastic thin shrink small outline package (TSSOP48)

DESCRIPTION

The HSTL16918 is a 9-bit to 18-bit D-type latch designed for 3.15 to 3.45 V V_{CC} operation. The D inputs accept HSTL levels and the Q outputs provide LVTTL levels.

The HSTL16918 is particularly suitable for driving an address bus to two banks of memory. Each bank of nine outputs is controlled with its own latch-enable (\overline{LE}) input.

Each of the nine D inputs is tied to the inputs of two D-type latches that provide true data (Q) at the outputs. While \overline{LE} is LOW the Q outputs of the corresponding nine latches follow the D inputs. When \overline{LE} is taken HIGH, the Q outputs are latched at the levels set up at the D inputs.

The HSTL16918 is characterized for operation from 0 to +70 °C.

PIN CONFIGURATION

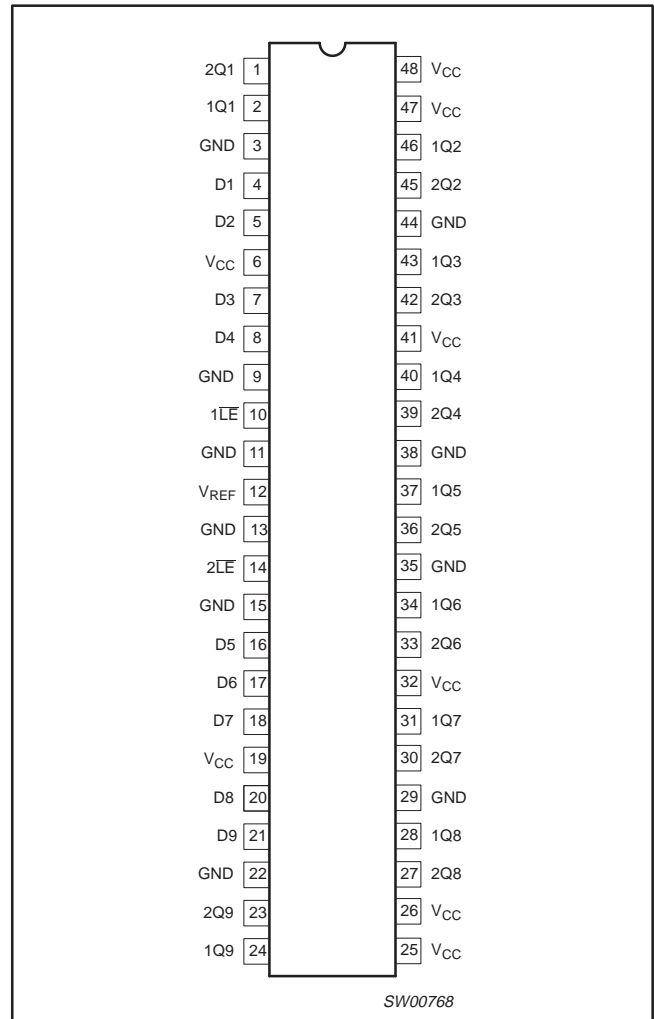

ORDERING INFORMATION

PACKAGES	TEMPERATURE RANGE	ORDER CODE	DWG NUMBER
48-pin plastic thin shrink small outline package (TSSOP48)	0 to +70 °C	HSTL16918DGG	SOT362-1

9-bit to 18-bit HSTL-to-LVTTL memory address latch

HSTL16918

PIN DESCRIPTION

PIN	SYMBOL	FUNCTION
4, 5, 7, 8, 16, 17, 18, 20, 21	D[1-9]	Inputs
2, 46, 43, 40, 37, 34, 31, 28, 24	1Q[1-9]	Outputs
1, 45, 42, 39, 36, 33, 30, 27, 23	2Q[1-9]	
10	1LE	Latch enable
14	2LE	
12	V _{REF}	Reference voltage
6, 19, 25, 26, 32, 41, 47, 48	V _{CC}	Supply voltage
3, 9, 11, 13, 15, 22, 29, 35, 38, 44	GND	Ground

LOGIC DIAGRAM (positive logic)

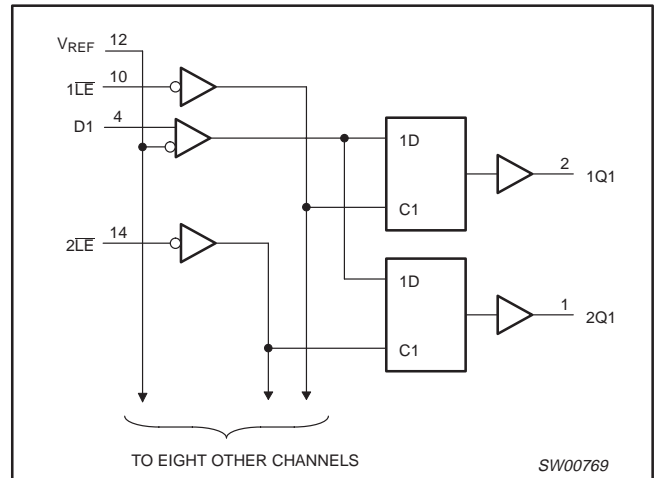

FUNCTION TABLE

INPUTS		OUTPUT Q
LE	D	
L	H	H
L	L	L
H	X	Q ₀ ¹

NOTE:

- Output level before the indicated steady-state input conditions were established.

9-bit to 18-bit HSTL-to-LVTTL memory address latch

HSTL16918

ABSOLUTE MAXIMUM RATINGS¹

Over operating free-air temperature range (unless otherwise noted).

SYMBOL	PARAMETER	CONDITIONS	RATING	UNIT
V_{CC}	Supply voltage range		-0.5 to +4.6	V
V_I	Input voltage range ²		-0.5 to $V_{CC} + 0.5$	V
V_O	Output voltage range ²		-0.5 to $V_{CC} + 0.5$	V
I_{IK}	Input clamp current	$V_I < 0$	-50	mA
I_{OK}	Output clamp current ³	$V_O < 0$ or $V_O > V_{CC}$	±50	mA
I_O	Continuous output current	$V_O = 0$ to V_{CC}	±50	mA
	Continuous current through each V_{CC} or GND		±100	mA
θ_{JA}	Package thermal impedance ⁴		89	°C/W
T_{stg}	Storage temperature range		-65 to +150	°C

NOTES:

- Stresses beyond those listed may cause permanent damage to the device. These are stress ratings only and functional operation of the device at these or any other conditions beyond those indicated under "recommended operating conditions" is not implied. Exposure to absolute-maximum-rated conditions for extended periods may affect device reliability.
- The input and output negative-voltage ratings may be exceeded if the input and output clamp-current ratings are observed.
- This current flows only when the output is in the high state and $V_O > V_{CC}$.
- The package thermal impedance is calculated in accordance with JESD 51.

RECOMMENDED OPERATING CONDITIONS¹

SYMBOL	PARAMETER		LIMITS			UNIT
			Min	Nom	Max	
V_{CC}	Supply voltage		3.15		3.45	V
V_{REF}	Reference voltage		0.68	0.75	0.9	V
V_I	Input voltage		0		1.5	V
V_{IH}	AC high-level input voltage	All inputs	$V_{REF} + 200$ mV			V
V_{IL}	AC low-level input voltage	All inputs			$V_{REF} - 200$ mV	V
V_{IH}	DC high-level input voltage	All inputs	$V_{REF} + 100$ mV			V
V_{IL}	DC low-level input voltage	All inputs			$V_{REF} - 100$ mV	V
I_{OH}	High-level output current				-24	mA
I_{OL}	Low-level output current				24	mA
T_{amb}	Operating free-air temperature range		0		+70	°C

NOTE:

- All unused inputs of the device must be held at V_{CC} or GND to ensure proper device operation.

9-bit to 18-bit HSTL-to-LVTTL memory address latch

HSTL16918

ELECTRICAL CHARACTERISTICS

Over recommended operating free-air temperature range (unless otherwise noted).

SYMBOL	PARAMETER	TEST CONDITIONS	LIMITS			UNIT
			Min	Typ ¹	Max	
V_{IK}		$V_{CC} = 3.15\text{ V}; I_I = -18\text{ mA}$			-1.2	V
V_{OH}		$V_{CC} = 3.15\text{ V}; I_{OH} = -24\text{ mA}$	2.4			V
V_{OL}		$V_{CC} = 3.15\text{ V}; I_{OL} = 24\text{ mA}$			0.5	V
I_I	Control inputs	$V_{CC} = 3.45\text{ V}; V_I = 0\text{ or }1.5\text{ V}$			± 5	μA
	Data inputs	$V_{CC} = 3.45\text{ V}; V_I = 0\text{ or }1.5\text{ V}$			± 5	μA
	V_{REF}	$V_{CC} = 3.45\text{ V}; V_{REF} = 0.68\text{ V or }0.9\text{ V}$			90	μA
I_{CC}		$V_{CC} = 3.45\text{ V}; V_I = 0\text{ or }1.5\text{ V}$		50	100	mA
C_I	Control inputs	$V_{CC} = 0\text{ or }3.3\text{ V}; V_I = 0\text{ or }3.3\text{ V}$		2		pF
	Data inputs	$V_{CC} = 0\text{ or }3.3\text{ V}; V_I = 0\text{ or }3.3\text{ V}$		2.5		pF
C_O	Outputs	$V_{CC} = 0\text{ V}; V_O = 0\text{ V}$		4		pF

NOTE:1. All typical values are at $V_{CC} = 3.3\text{ V}; T_{amb} = 25\text{ }^\circ\text{C}$.**TIMING REQUIREMENTS**

Over recommended operating free-air temperature range (unless otherwise noted).

SYMBOL	PARAMETER	TEST CONDITIONS	$V_{CC} = 3.3\text{ V} \pm 0.15\text{ V}$		UNIT
			Min	Max	
t_w	Pulse duration	LE LOW (Figure 1)	3		ns
t_{su}	Setup time	D before $\overline{LE} \uparrow$ (Figure 2)	2		ns
t_h	Hold time	D after $\overline{LE} \uparrow$ (Figure 2)	1		ns
t_{ldr}	Data race condition time ¹	D after $\overline{LE} \downarrow$		0	ns

NOTE:1. This is the maximum time after \overline{LE} switches LOW that the data input can return to the latched state from the opposite state without producing a glitch on the output.**SWITCHING CHARACTERISTICS**Over recommended operating free-air temperature range; $V_{REF} = 0.75\text{ V}$.

SYMBOL	PARAMETER	FROM (INPUT)	TO (OUTPUT)	$V_{CC} = 3.3\text{ V} \pm 0.15\text{ V}$		UNIT
				Min	Max	
t_{pd}	Propagation delay (Figure 3)	D	Q	1.9	3.4	ns
		\overline{LE}	Q	1.9	4.2	ns

SIMULTANEOUS SWITCHING CHARACTERISTICSOver recommended operating free-air temperature range; $V_{REF} = 0.75\text{ V}$

SYMBOL	PARAMETER	FROM (INPUT)	TO (OUTPUT)	$V_{CC} = 3.3\text{ V} \pm 0.15\text{ V}$		UNIT
				Min	Max	
t_{pd}	Propagation delay; all outputs switching (Figure 3)	D	Q	1.9	4.4	ns
		\overline{LE}	Q	1.9	5.2	ns

9-bit to 18-bit HSTL-to-LVTTL memory address latch

HSTL16918

VOLTAGE WAVEFORMS

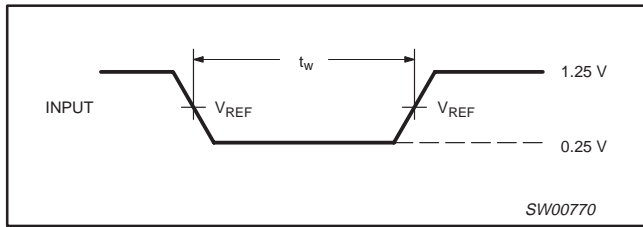
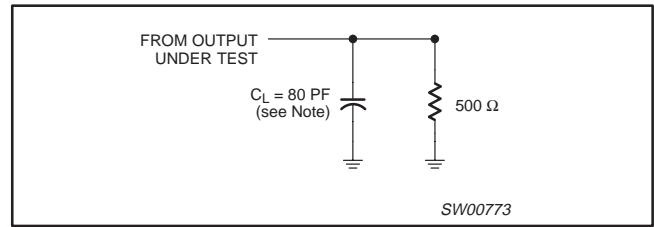

Figure 1. Pulse duration

LOAD CIRCUIT



NOTE: C_L includes probe and jig capacitance.

Figure 4. Load circuit

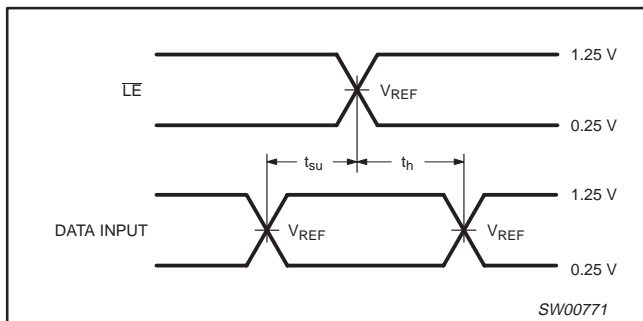

Figure 2. Setup and Hold times

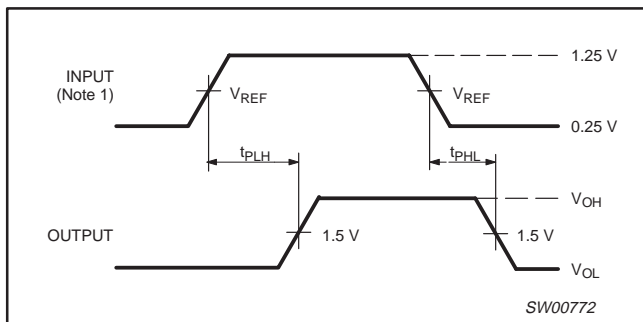

Figure 3. Propagation delay times

NOTES:

1. All input pulses are supplied by generators having the following characteristics: PRR ≤ 10 MHz, Z_O = 50 Ω, t_r ≤ 1 ns, t_f ≤ 1 ns.
2. The outputs are measured one at a time with one transition per measurement.
3. t_{P_{HL}} and t_{P_{LH}} are the same as t_{pd}.

9-bit to 18-bit HSTL-to-LVTTL memory address latch

HSTL16918

TSSOP48: plastic thin shrink small outline package; 48 leads; body width 6.1 mm

SOT362-1

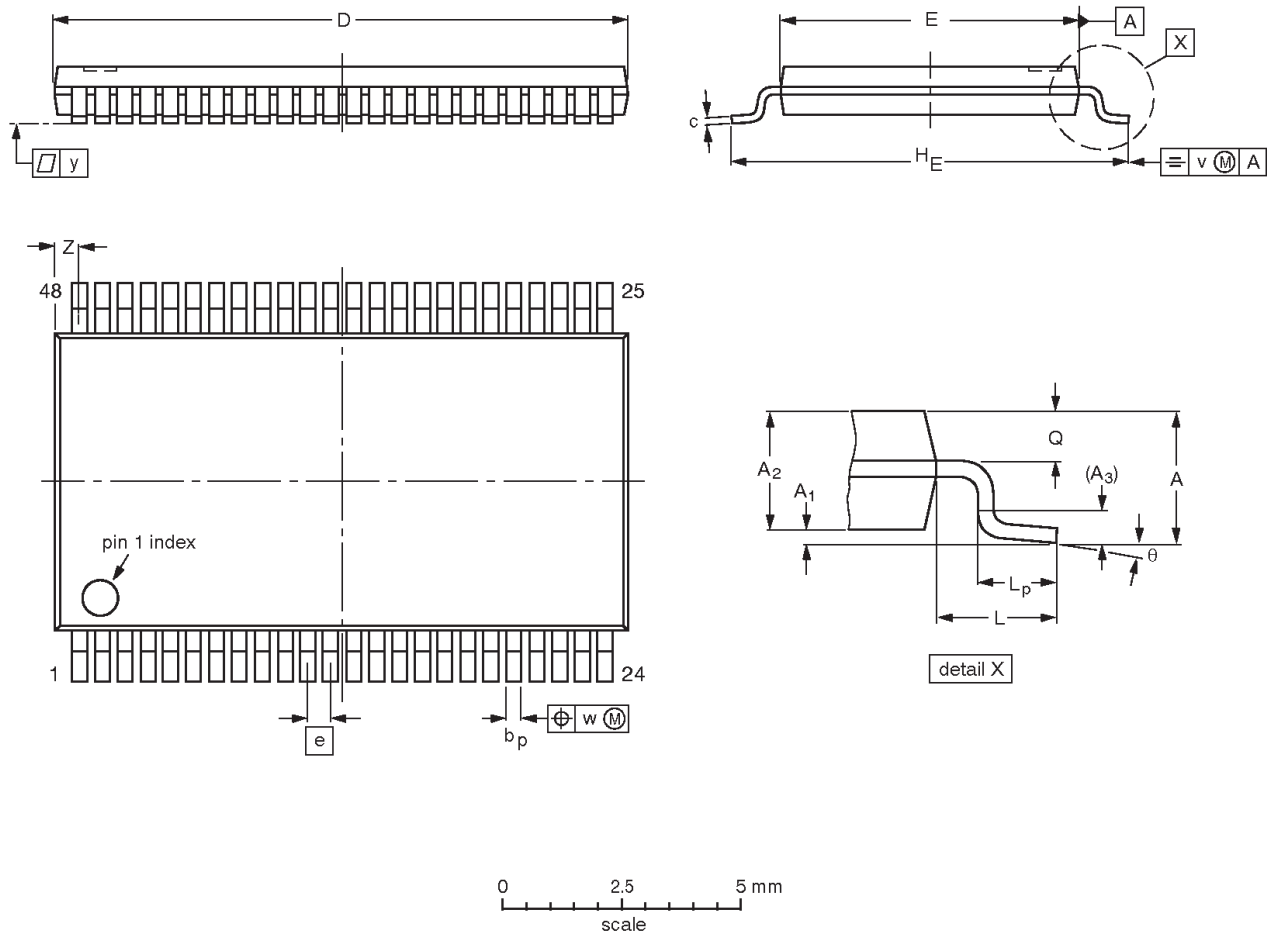

DIMENSIONS (mm are the original dimensions).

UNIT	A max.	A ₁	A ₂	A ₃	b _p	c	D ⁽¹⁾	E ⁽²⁾	e	H _E	L	L _p	Q	v	w	y	Z	θ
mm	1.2	0.15 0.05	1.05 0.85	0.25	0.28 0.17	0.2 0.1	12.6 12.4	6.2 6.0	0.5	8.3 7.9	1	0.8 0.4	0.50 0.35	0.25	0.08	0.1	0.8 0.4	8° 0°

Notes

1. Plastic or metal protrusions of 0.15 mm maximum per side are not included.
2. Plastic interlead protrusions of 0.25 mm maximum per side are not included.

OUTLINE VERSION	REFERENCES				EUROPEAN PROJECTION	ISSUE DATE
	IEC	JEDEC	EIAJ			
SOT362-1		MO-153				-95-02-10 99-12-27

9-bit to 18-bit HSTL-to-LVTTL memory address latch

HSTL16918

Data sheet status

Data sheet status ^[1]	Product status ^[2]	Definitions
Objective data	Development	This data sheet contains data from the objective specification for product development. Philips Semiconductors reserves the right to change the specification in any manner without notice.
Preliminary data	Qualification	This data sheet contains data from the preliminary specification. Supplementary data will be published at a later date. Philips Semiconductors reserves the right to change the specification without notice, in order to improve the design and supply the best possible product.
Product data	Production	This data sheet contains data from the product specification. Philips Semiconductors reserves the right to make changes at any time in order to improve the design, manufacturing and supply. Changes will be communicated according to the Customer Product/Process Change Notification (CPCN) procedure SNW-SQ-650A.

[1] Please consult the most recently issued datasheet before initiating or completing a design.

[2] The product status of the device(s) described in this data sheet may have changed since this data sheet was published. The latest information is available on the Internet at URL <http://www.semiconductors.philips.com>.

Definitions

Short-form specification — The data in a short-form specification is extracted from a full data sheet with the same type number and title. For detailed information see the relevant data sheet or data handbook.

Limiting values definition — Limiting values given are in accordance with the Absolute Maximum Rating System (IEC 134). Stress above one or more of the limiting values may cause permanent damage to the device. These are stress ratings only and operation of the device at these or at any other conditions above those given in the Characteristics sections of the specification is not implied. Exposure to limiting values for extended periods may affect device reliability.

Application information — Applications that are described herein for any of these products are for illustrative purposes only. Philips Semiconductors make no representation or warranty that such applications will be suitable for the specified use without further testing or modification.

Disclaimers

Life support — These products are not designed for use in life support appliances, devices or systems where malfunction of these products can reasonably be expected to result in personal injury. Philips Semiconductors customers using or selling these products for use in such applications do so at their own risk and agree to fully indemnify Philips Semiconductors for any damages resulting from such application.

Right to make changes — Philips Semiconductors reserves the right to make changes, without notice, in the products, including circuits, standard cells, and/or software, described or contained herein in order to improve design and/or performance. Philips Semiconductors assumes no responsibility or liability for the use of any of these products, conveys no license or title under any patent, copyright, or mask work right to these products, and makes no representations or warranties that these products are free from patent, copyright, or mask work right infringement, unless otherwise specified.

Philips Semiconductors
811 East Arques Avenue
P.O. Box 3409
Sunnyvale, California 94088-3409
Telephone 800-234-7381

© Copyright Philips Electronics North America Corporation 2001
All rights reserved. Printed in U.S.A.

Date of release: 06-01

Document order number:

9397 750 08474

Let's make things better.



LittleDiode supplies new, hard to find or obsolete electronic components and semiconductors all over the world.

With over two million different components listed you are sure to find the part you need.

Feel free to visit us today at our online store:

LittleDiode.com

Looking forward to providing you with the best possible service.