

**Features**

- Low power consumption
- Low voltage dropout
- Low temperature coefficient
- Wide operating voltage (12V Max.)
- TO-92 & SOT-89 packages

**Applications**

- Battery-powered equipment
- Communication equipment
- Audio/Video equipment

**General Description**

The HT10XX series is a set of three-terminal low power voltage regulators implemented in CMOS technology. They are available with several fixed output voltages ranging from 1.5V~7.0V. The advantage of CMOS technology is low voltage dropout and low quiescent current.

Although designed primarily as fixed voltage regulators, these devices can be used with external components to obtain variable voltages and currents.

**Pin Assignment**

A. TO-92

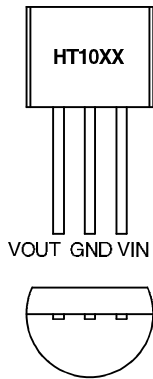

B. TO-92

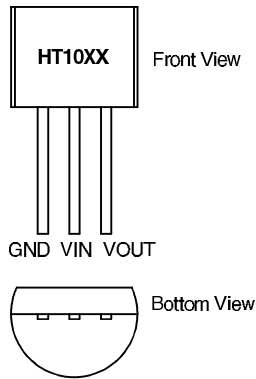

C. SOT-89

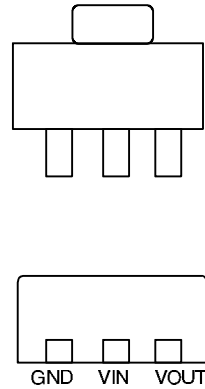

**Pad Assignment**

Unit: mil

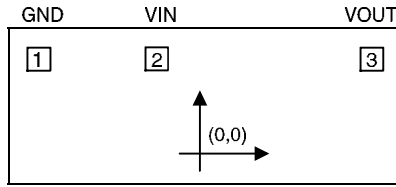

Pad No.	X	Y
1	-28.2	16.6
2	-7.55	16.7
3	-30.1	16.6

Chip size:  $76 \times 50 \text{ (mil)}^2$

\*The IC substrate should be connected to VDD in the PCB layout artwork.

**Block Diagram**

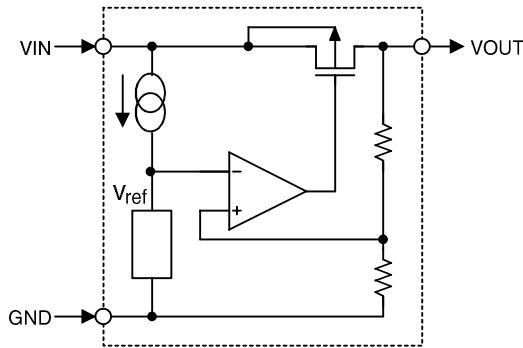

**Absolute Maximum Ratings**

Supply Voltage ..... -0.3V to 13V  
 Power Dissipation ..... 250mW

Storage Temperature ..... -50°C to 125°C  
 Operating Temperature ..... 0°C to 70°C

**Selection Guide**

Item	Pin Assignment	Output Voltage	Tolerance
HT1015 HT1016	B A	1.5V	±2.4%, ±5%
HT1030 HT1031	B A	3.0V	±2.4%, ±5%
HT1033 HT1034	B A	3.3V	±2.4%, ±5%
HT1036 HT1037	B A	3.6V	±2.4%, ±5%
HT1044 HT1045	B A	4.4V	±2.4%, ±5%
HT1050 HT1051	B A	5.0V	±2.4%, ±5%
HT1070 HT1071	B A	7.0V	±2.4%, ±5%

**Electrical Characteristics**

HT10XX series (HT1015, HT1016, +1.5V output type)

(Ta=25°C)

Symbol	Parameter	Test Condition		Min.	Typ.	Max.	Unit
		V <sub>IN</sub>	Condition				
V <sub>OUT</sub>	Output Voltage Tolerance	3.5V	I <sub>OUT</sub> =0.5mA	1.425	1.5	1.575	V
I <sub>OUT</sub>	Output Current	3.5V	—	7.0	—	—	mA
ΔV <sub>OUT</sub>	Load Regulation	3.5V	1mA≤I <sub>OUT</sub> ≤7mA	—	80	—	mV
V <sub>DIF</sub>	Voltage Dropout	—	I <sub>OUT</sub> =0.5mA	—	300	—	mV
I <sub>SS</sub>	Current Consumption	3.5V	No load	—	2.2	5.0	μA
$\frac{\Delta V_{OUT}}{\Delta V_{IN} \cdot V_{OUT}}$	Line Regulation	—	2.5V≤V <sub>IN</sub> ≤12V I <sub>OUT</sub> =0.5mA	—	0.2	—	%/V
V <sub>IN</sub>	Input Voltage	—	—	—	—	12	V
$\frac{\Delta V_{OUT}}{\Delta T_a}$	Temperature Coefficient	3.5V	I <sub>OUT</sub> =0.5mA 0°C<Ta<70°C	—	±0.25	—	mV/°C

**HT10XX series (HT1030, HT1031, +3.0V output type)**

(Ta=25°C)

Symbol	Parameter	Test Condition		Min.	Typ.	Max.	Unit
		V <sub>IN</sub>	Condition				
V <sub>OUT</sub>	Output Voltage Tolerance	5V	I <sub>OUT</sub> =10mA	2.85	3.0	3.15	V
I <sub>OUT</sub>	Output Current	5V	—	20	30	—	mA
ΔV <sub>OUT</sub>	Load Regulation	5V	1mA ≤ I <sub>OUT</sub> ≤ 20mA	—	60	100	mV
V <sub>DIF</sub>	Voltage Dropout	—	I <sub>OUT</sub> =1mA	—	60	—	mV
I <sub>SS</sub>	Current Consumption	5V	No load	—	2.5	6.0	μA
$\frac{\Delta V_{OUT}}{\Delta V_{IN} \cdot V_{OUT}}$	Line Regulation	—	4V ≤ V <sub>IN</sub> ≤ 12V I <sub>OUT</sub> =1mA	—	0.2	—	%/V
V <sub>IN</sub>	Input Voltage	—	—	—	—	12	V
$\frac{\Delta V_{OUT}}{\Delta T_a}$	Temperature Coefficient	5V	I <sub>OUT</sub> =10mA 0°C < Ta < 70°C	—	±0.45	—	mV/°C

**HT10XX series (HT1033, HT1034, +3.3V output type)**

(Ta=25°C)

Symbol	Parameter	Test Condition		Min.	Typ.	Max.	Unit
		V <sub>IN</sub>	Condition				
V <sub>OUT</sub>	Output Voltage Tolerance	5.5V	I <sub>OUT</sub> =10mA	3.135	3.3	3.465	V
I <sub>OUT</sub>	Output Current	5.5V	—	20	30	—	mA
ΔV <sub>OUT</sub>	Load Regulation	5.5V	1mA ≤ I <sub>OUT</sub> ≤ 30mA	—	60	100	mV
V <sub>DIF</sub>	Voltage Dropout	—	I <sub>OUT</sub> =1mA	—	60	—	mV
I <sub>SS</sub>	Current Consumption	5.5V	No load	—	2.5	6.0	μA
$\frac{\Delta V_{OUT}}{\Delta V_{IN} \cdot V_{OUT}}$	Line Regulation	—	4.5V ≤ V <sub>IN</sub> ≤ 12V I <sub>OUT</sub> =1mA	—	0.2	—	%/V
V <sub>IN</sub>	Input Voltage	—	—	—	—	12	V
$\frac{\Delta V_{OUT}}{\Delta T_a}$	Temperature Coefficient	5.5V	I <sub>OUT</sub> =10mA 0°C < Ta < 70°C	—	±0.5	—	mV/°C

**HT10XX series (HT1036, HT1037, +3.6V output type)**

(Ta=25°C)

Symbol	Parameter	Test Condition		Min.	Typ.	Max.	Unit
		V <sub>IN</sub>	Condition				
V <sub>OUT</sub>	Output Voltage Tolerance	5.6V	I <sub>OUT</sub> =10mA	3.42	3.6	3.78	V
I <sub>OUT</sub>	Output Current	5.6V	—	20	30	—	mA
ΔV <sub>OUT</sub>	Load Regulation	5.6V	1mA≤I <sub>OUT</sub> ≤30mA	—	60	100	mV
V <sub>DIF</sub>	Voltage Dropout	—	I <sub>OUT</sub> =1mA	—	60	—	mV
I <sub>SS</sub>	Current Consumption	5.6V	No load	—	3.0	7.0	μA
$\frac{\Delta V_{OUT}}{\Delta V_{IN} \cdot V_{OUT}}$	Line Regulation	—	4.6V≤V <sub>IN</sub> ≤12V I <sub>OUT</sub> =1mA	—	0.2	—	%/V
V <sub>IN</sub>	Input Voltage	—	—	—	—	12	V
$\frac{\Delta V_{OUT}}{\Delta T_a}$	Temperature Coefficient	5.6V	I <sub>OUT</sub> =10mA 0°C<Ta<70°C	—	±0.6	—	mV/°C

**HT10XX series (HT1044, HT1045, +4.4V output type)**

(Ta=25°C)

Symbol	Parameter	Test Condition		Min.	Typ.	Max.	Unit
		V <sub>IN</sub>	Condition				
V <sub>OUT</sub>	Output Voltage Tolerance	6.4V	I <sub>OUT</sub> =10mA	4.18	4.4	4.62	V
I <sub>OUT</sub>	Output Current	6.4V	—	20	30	—	mA
ΔV <sub>OUT</sub>	Load Regulation	6.4V	1mA≤I <sub>OUT</sub> ≤30mA	—	60	100	mV
V <sub>DIF</sub>	Voltage Dropout	—	I <sub>OUT</sub> =1mA	—	60	—	mV
I <sub>SS</sub>	Current Consumption	6.4V	No load	—	3.0	7.5	μA
$\frac{\Delta V_{OUT}}{\Delta V_{IN} \cdot V_{OUT}}$	Line Regulation	—	5.4V≤V <sub>IN</sub> ≤12V I <sub>OUT</sub> =1mA	—	0.2	—	%/V
V <sub>IN</sub>	Input Voltage	—	—	—	—	12	V
$\frac{\Delta V_{OUT}}{\Delta T_a}$	Temperature Coefficient	6.4V	I <sub>OUT</sub> =10mA 0°C<Ta<70°C	—	±0.7	—	mV/°C

**HT10XX series (HT1050, HT1051, +5.0V output type)**

(Ta=25°C)

Symbol	Parameter	Test Condition		Min.	Typ.	Max.	Unit
		V <sub>IN</sub>	Condition				
V <sub>OUT</sub>	Output Voltage Tolerance	7V	I <sub>OUT</sub> =10mA	4.75	5.0	5.25	V
I <sub>OUT</sub>	Output Current	7V	—	20	30	—	mA
ΔV <sub>OUT</sub>	Load Regulation	7V	1mA≤I <sub>OUT</sub> ≤30mA	—	60	100	mV
V <sub>DIF</sub>	Voltage Dropout	—	I <sub>OUT</sub> =1mA	—	60	—	mV
I <sub>SS</sub>	Current Consumption	7V	No load	—	3.5	9.0	μA
$\frac{\Delta V_{OUT}}{\Delta V_{IN} \cdot V_{OUT}}$	Line Regulation	—	6V≤V <sub>IN</sub> ≤12V I <sub>OUT</sub> =1mA	—	0.2	—	%/V
V <sub>IN</sub>	Input Voltage	—	—	—	—	12	V
$\frac{\Delta V_{OUT}}{\Delta T_a}$	Temperature Coefficient	7V	I <sub>OUT</sub> =10mA 0°C<Ta<70°C	—	±0.75	—	mV/°C

**HT10XX series (HT1070, HT1071, +7.0V output type)**

(Ta=25°C)

Symbol	Parameter	Test Condition		Min.	Typ.	Max.	Unit
		V <sub>IN</sub>	Condition				
V <sub>OUT</sub>	Output Voltage Tolerance	9V	I <sub>OUT</sub> =10mA	6.65	7.0	7.35	V
I <sub>OUT</sub>	Output Current	9V	—	20	30	—	mA
ΔV <sub>OUT</sub>	Load Regulation	9V	1mA≤I <sub>OUT</sub> ≤30mA	—	60	100	mV
V <sub>DIF</sub>	Voltage Dropout	—	I <sub>OUT</sub> =1mA	—	60	—	mV
I <sub>SS</sub>	Current Consumption	9V	No load	—	5.0	12.5	μA
$\frac{\Delta V_{OUT}}{\Delta V_{IN} \cdot V_{OUT}}$	Line Regulation	—	8V≤V <sub>IN</sub> ≤12V I <sub>OUT</sub> =1mA	—	0.2	—	%/V
V <sub>IN</sub>	Input Voltage	—	—	—	—	12	V
$\frac{\Delta V_{OUT}}{\Delta T_a}$	Temperature Coefficient	9V	I <sub>OUT</sub> =10mA 0°C<Ta<70°C	—	±1.05	—	mV/°C

### Application Circuit

The basic circuits using the HT10XX series

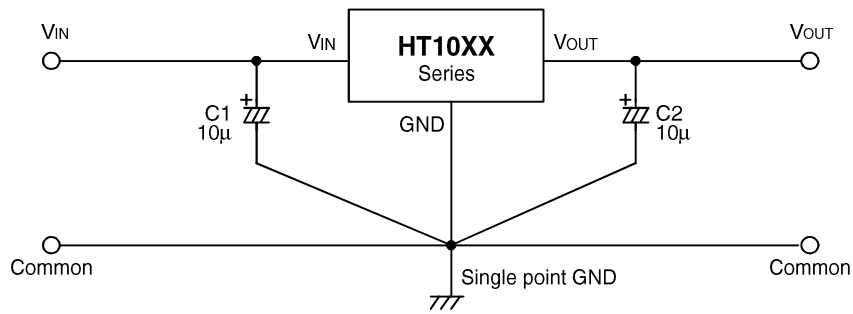

### High output current positive voltage regulator

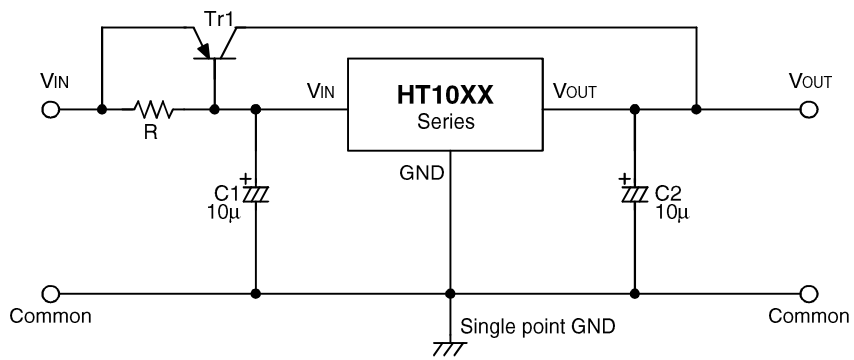

### Short-Circuit protection for $Tr1$

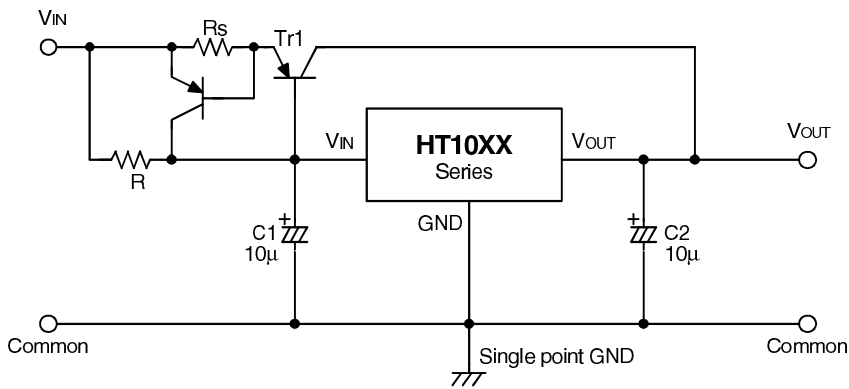

Circuit for increasing output voltage

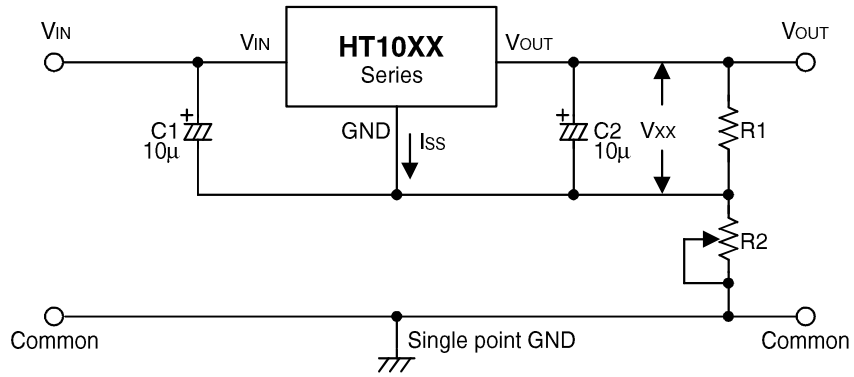

$$V_{OUT} = V_{XX} \left( 1 + \frac{R_2}{R_1} \right) + I_{SS} R_2$$

$$\approx V_{XX} \left( 1 + \frac{R_2}{R_1} \right)$$

Circuit for increasing output voltage

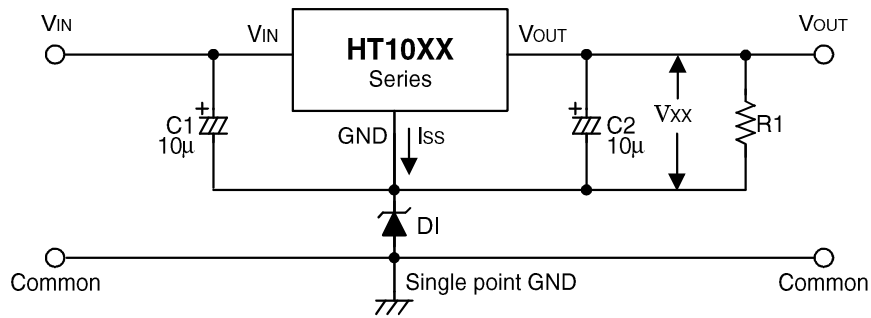

$$V_{OUT} = V_{XX} + V_{DI}$$

Constant current regulator

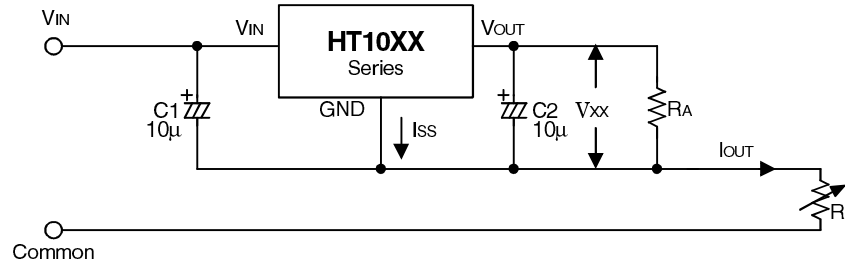

$$I_{OUT} = \frac{V_{XX}}{R_A} + I_{SS}$$

Dual supply

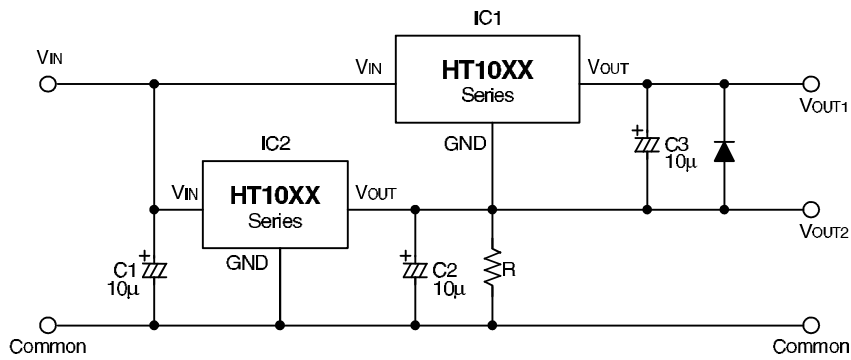

Package Information

TO-92

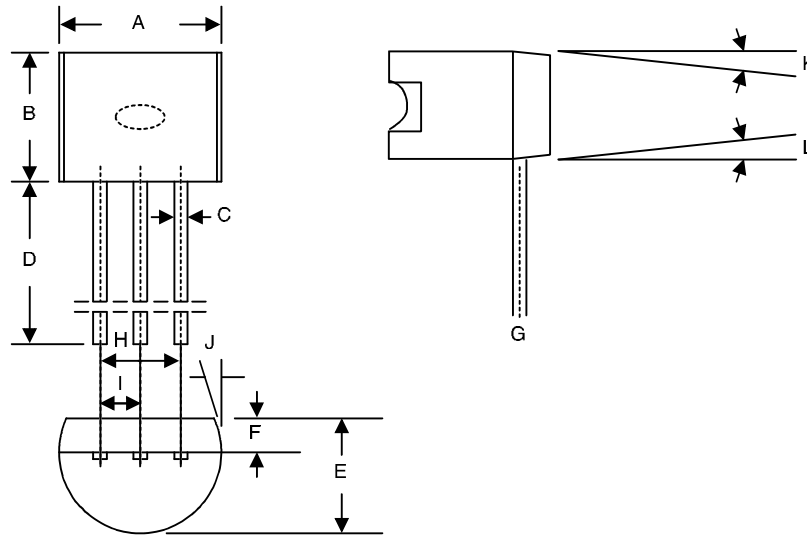

	mm	inches	degree		mm	inches	degree
A	4.57	0.180	—	I	1.27	0.050	—
B	4.57	0.180	—	J	—	—	5
C	0.38	0.015	—	K	—	—	2
D	13.5	0.531	—	L	—	—	2
E	3.66	0.140	—				
F	1.27	0.050					
G	0.39	0.011					
H	2.54	0.100					

SOT-89 outline

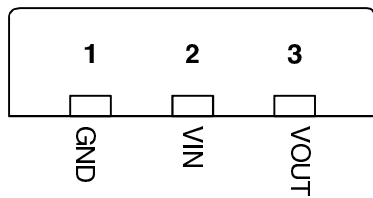
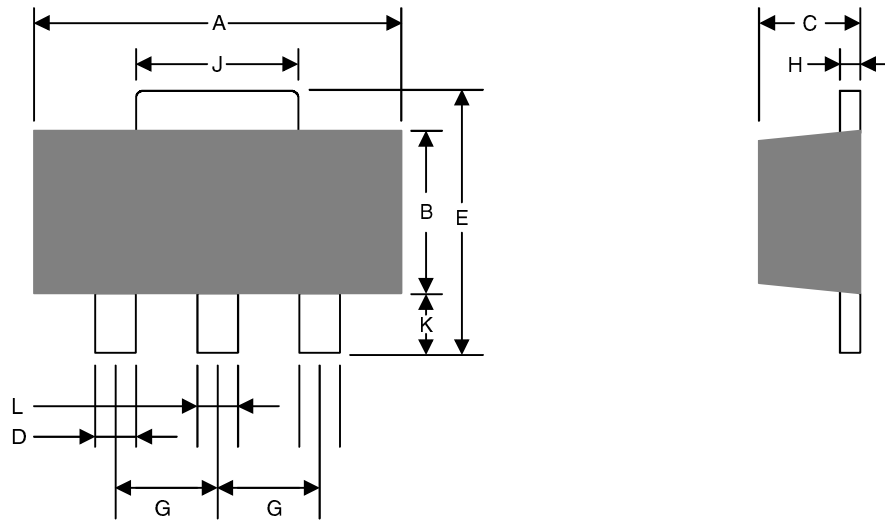

	mm	inches		mm	inches
A	4.60	0.18	I		
B	2.60	0.102	J	1.70	0.669
C	1.60	0.063	K	0.80	0.031
D	0.48	0.019	L	0.53	0.021
E	4.20	0.165			
F					
G	1.50	0.059			
H	0.45	0.018			

Type form and dimensions

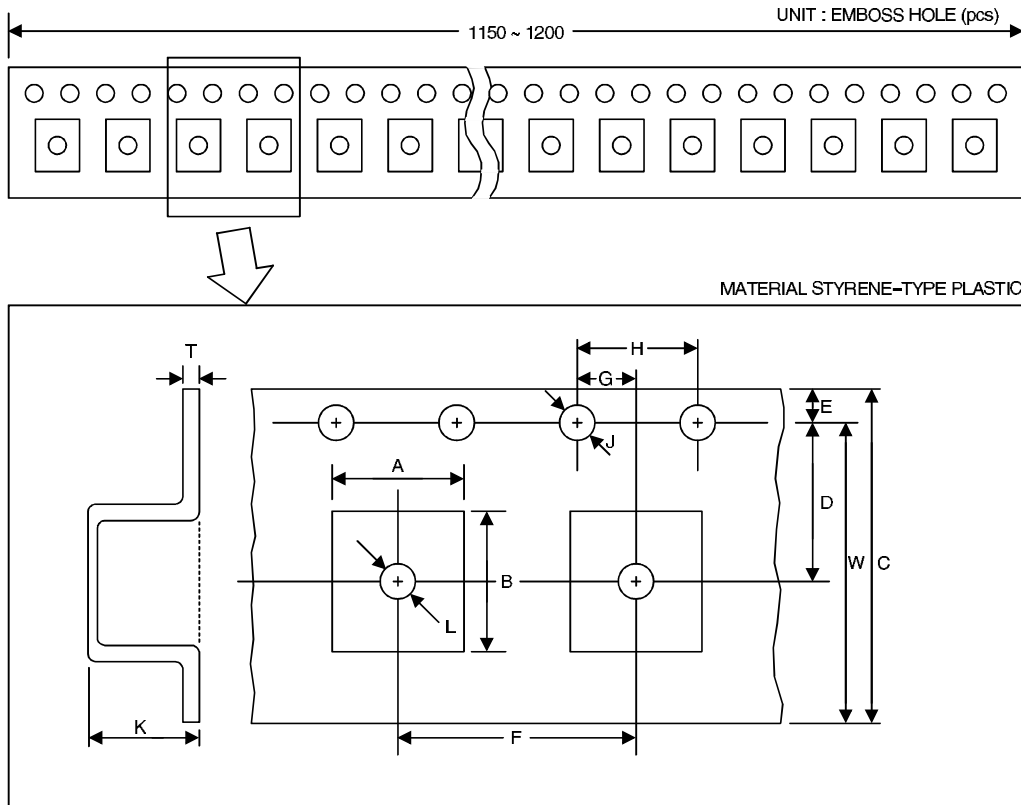

Dimensions

SYMBOL	A	B	C	D	E	F	G	H	J	K	W	T	L
VALUE	5.0	4.6	12	5.65	1.5	8.0	2.0	4.0	φ1.5	1.7	10.5	0.3	φ1.6
TOLERANCE	±0.1	±0.1	±0.2	±0.05	±0.1	±0.1	±0.05	±0.1	±0.1	±0.1	±0.1	±0.05	±0.1

\* Total 10 Pitch tolerance ± 2mm

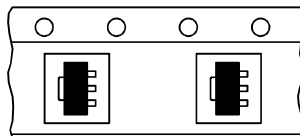

Reel form and dimensions

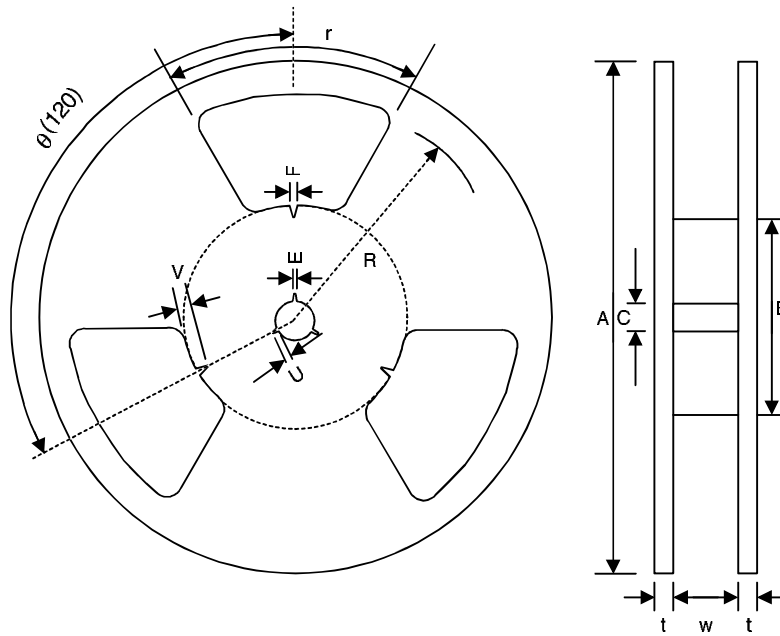

A	B	C	E	F	U	V	R	r	w	t
$\phi$ 178±2	$\phi$ 80±1	$\phi$ 13±0.5	20±0.5	1.5±0.5	4±0.5	6±1	70±1	40°	14±1.5	2±0.1

Leader and trailer portion

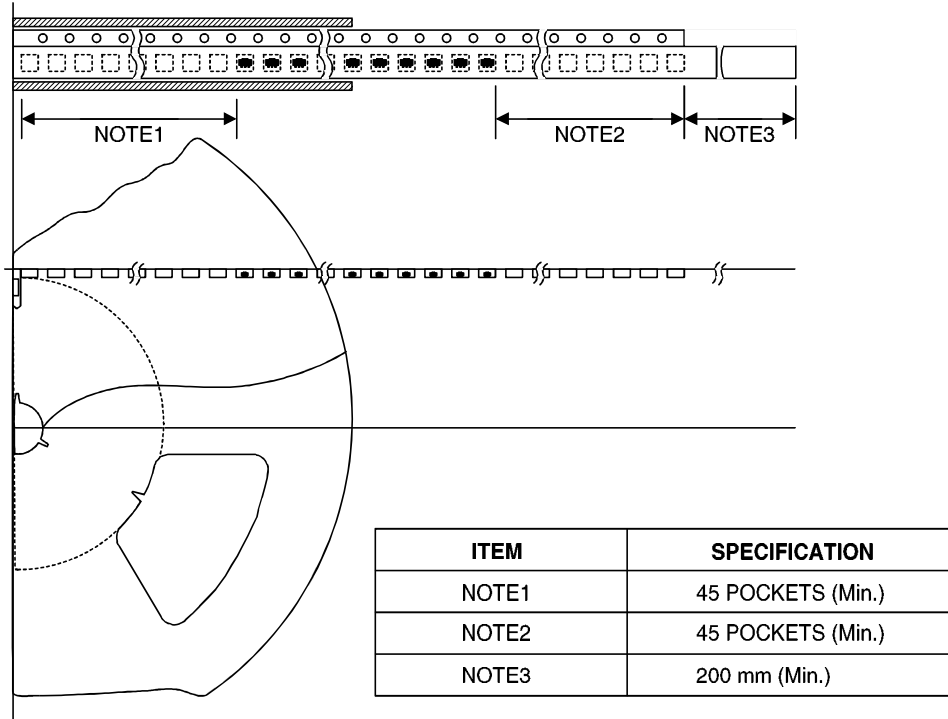

Taped parts quantity

1000 Pcs/1 reel (-0/+10PCS)

Mechanical data

ITEM	DATA	REMARK
Cover tape	30 ~ 60g	Carrier tape and cover tape open angle 0 ~ 5°
Adhesion		F=120±5mm/minute

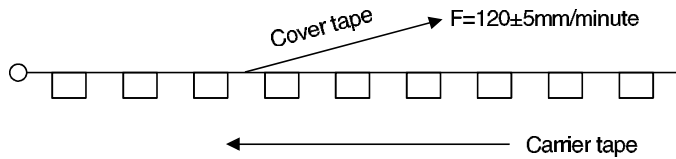

This datasheet has been downloaded from:

[www.DatasheetCatalog.com](http://www.DatasheetCatalog.com)

Datasheets for electronic components.



LittleDiode supplies new, hard to find or obsolete electronic components and semiconductors all over the world.

With over two million different components listed you are sure to find the part you need.

Feel free to visit us today at our online store:

[LittleDiode.com](http://LittleDiode.com)

Looking forward to providing you with the best possible service.