

## DP83223 TWISTER High Speed Networking Transceiver Device

### General Description

The DP83223 Twisted Pair Transceiver is an integrated circuit capable of driving and receiving three-level (MLT-3) encoded datastreams. The DP83223 Transceiver is designed to interface directly with National Semiconductor's Fast Ethernet and FDDI Chip Sets or similar Physical Layer silicon allowing low cost data links over copper based media. The DP83223 allows links of up to 100 meters over Shielded Twisted Pair (Type-1A STP) and Category-5 datagrade Unshielded Twisted Pair (Cat-5 UTP) or equivalent. The DP83223 is available in a 28 pin PLCC package and a 32 pin PQFP package.

### Features

- Compatible with ANSI X3.263 TP-PMD draft standard
- Allows use of Type 1 STP and Category 5 UTP cables
- Requires a single +5V supply
- Integrated transmitter and receiver with adaptive equalization circuit
- Isolated TX and RX power supplies for minimum noise coupling
- Loopback feature for board diagnostics
- Digitally Synthesized transmit signal transition time control for reduced EMI
- Programmable transmit voltage amplitude
- Suitable for 100BASE-TX Fast Ethernet and Twisted Pair FDDI applications

### System Connection Diagrams

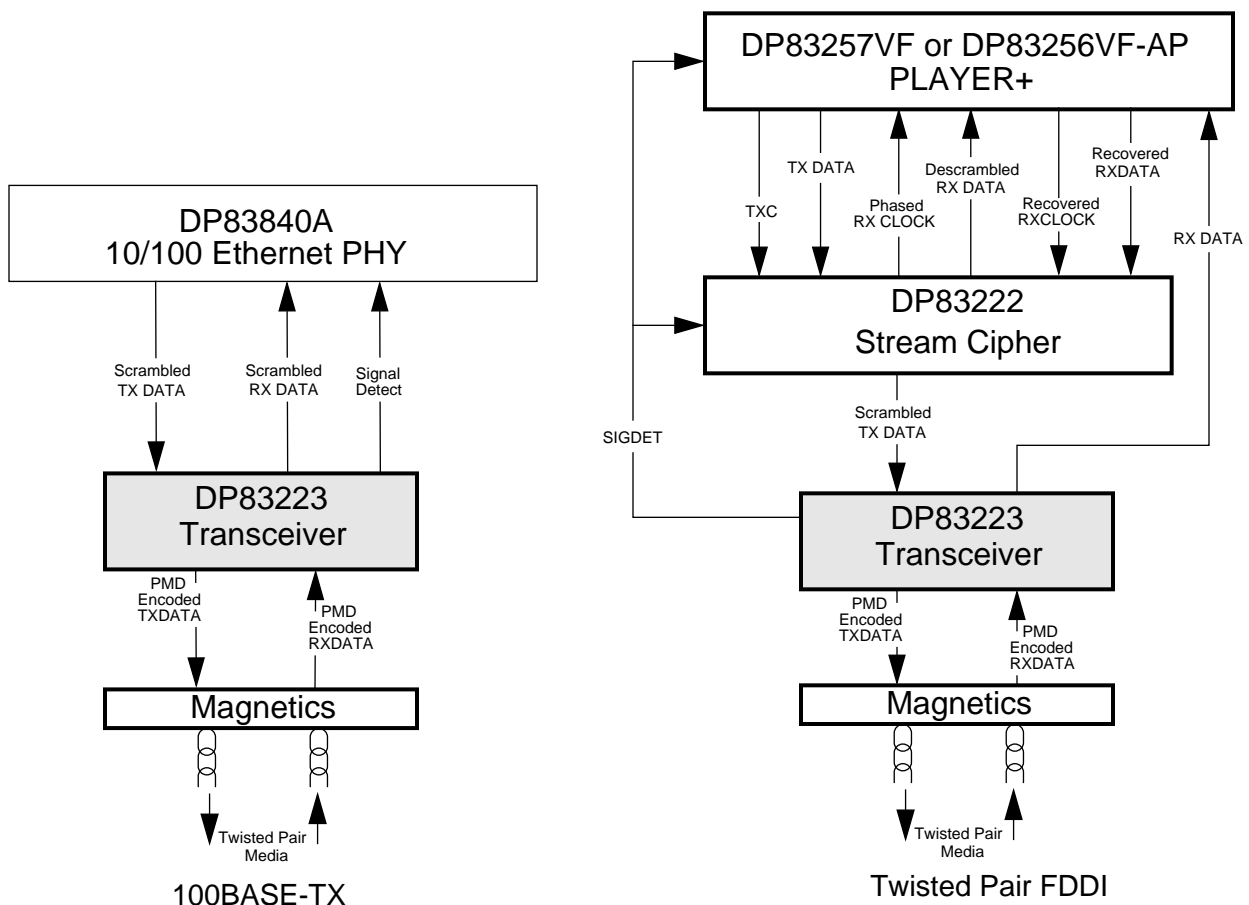

**General Description** (Continued)

**Table of Contents**

- 1.0 Connection Diagram
- 2.0 Pin Description
- 3.0 Functional Description
  - 3.1 Overview
  - 3.2 MLT-3 Encoding
  - 3.3 Transition Time Control
  - 3.4 Adaptive Equalization
  - 3.5 Jitter Performance
- 4.0 DC and AC Specifications
  - 4.1 TRANSMIT TIMING
  - 4.2 RECEIVE PROPAGATION DELAY
  - 4.3 LOOPBACK PROPAGATION DELAY
  - 4.4 SIGNAL DETECT TIMING
  - 4.5 ADAPTIVE EQUALIZER TIMING

**Block Diagram**

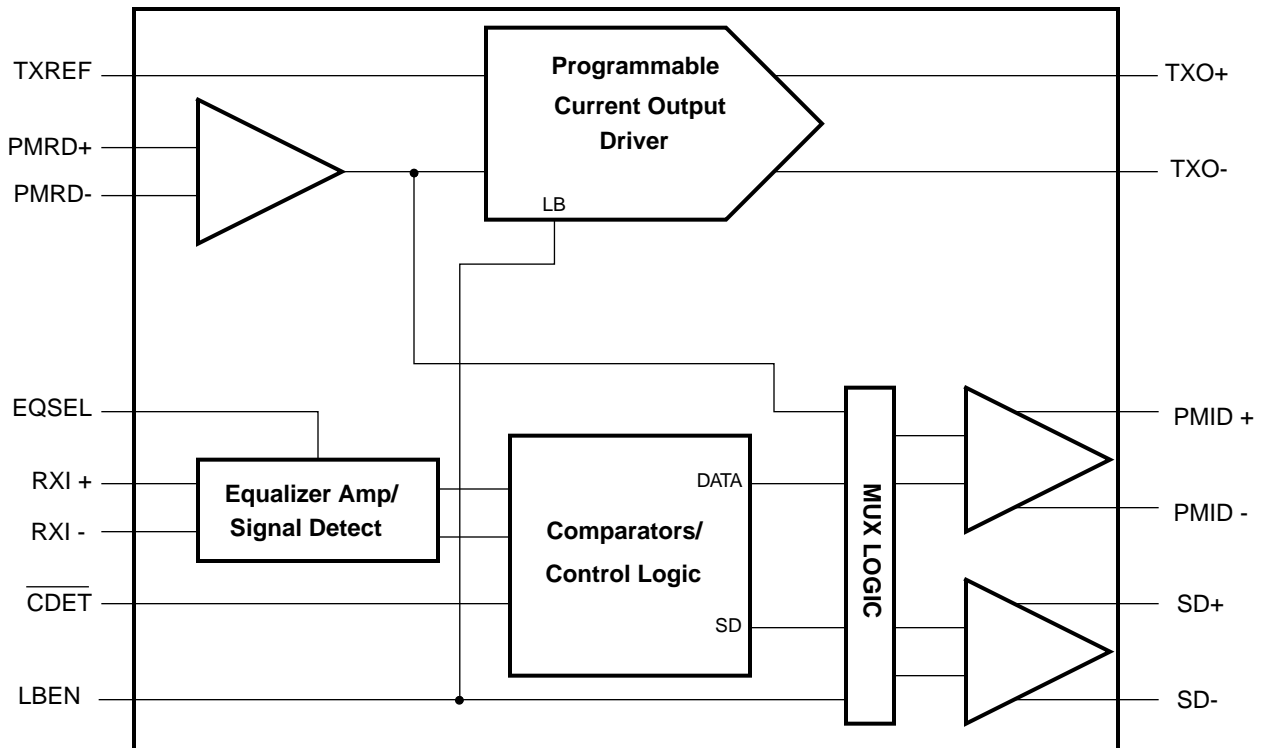

# 1.0 Connection Diagram

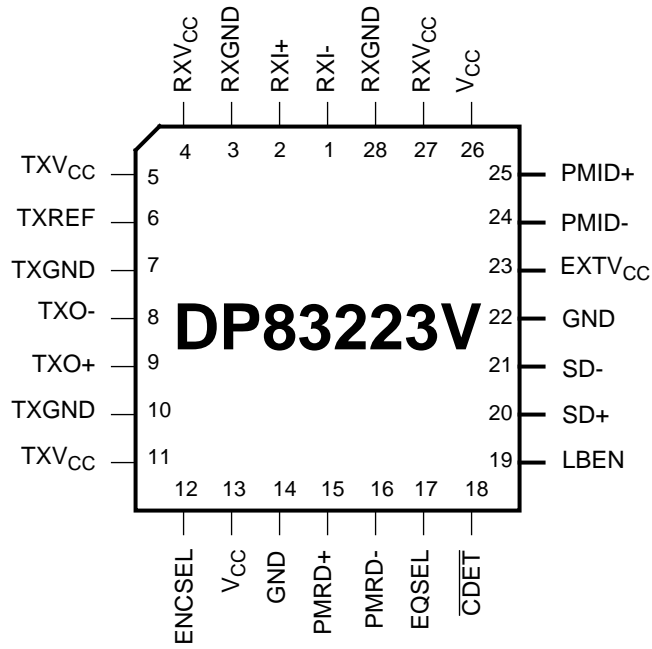

**28 Pin PLCC**  
**Order Number DP83223V**  
**See NS Package Number V28A**

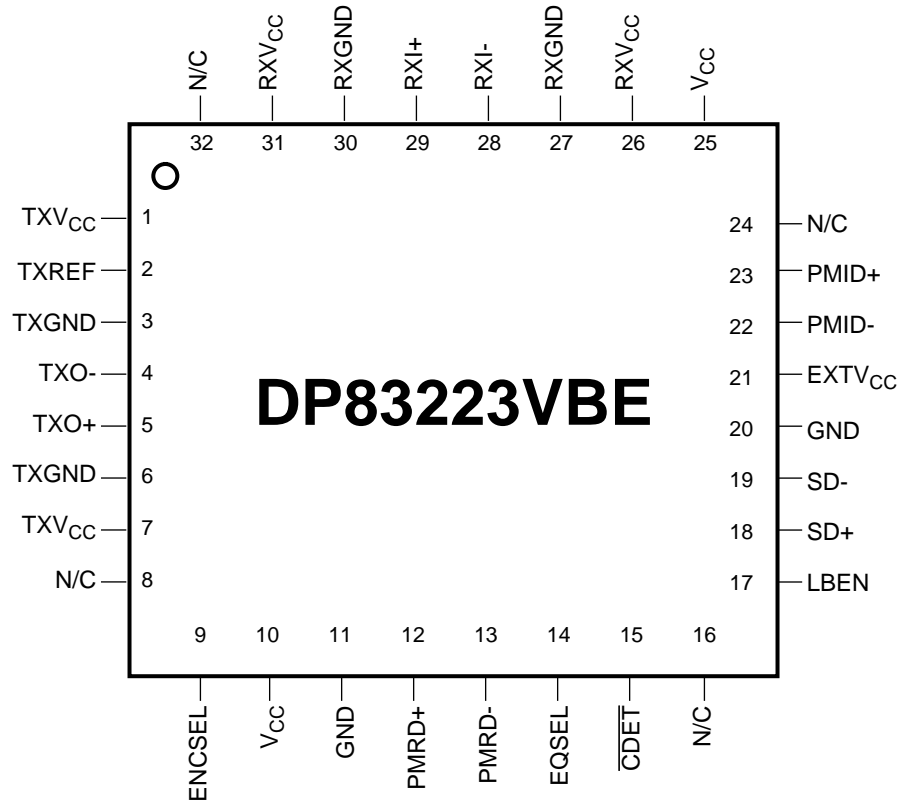

**32 Pin PQFP**  
**Order Number DP83223VBE**  
**See NS Package Number VBE32A**

## 2.0 Pin Description

### DP83223 Pinout Summary

Symbol	Pin No PLCC(PQFP)	Type	Description
V <sub>CC</sub>	13,26 (10, 25)	Supply	<b>V<sub>CC</sub></b> : Positive power supply for the ECL compatible circuitry. The Transceiver operates from a single +5VDC power supply.
GND	14, 22(11 ,20)	Supply	<b>GND</b> : Return path for the ECL compatible circuitry power supply.
RXV <sub>cc</sub>	4, 27(26, 31)	Supply	<b>Receive V<sub>cc</sub></b> : Positive power supply for the small signal receive circuitry. This power supply is intentionally separated from others to eliminate receive errors due to coupled supply noise.
RXGND	3, 28(27, 30)	Supply	<b>Receive GND</b> : Return path for the receive power supply circuitry. This power supply return is intentionally separated from others to eliminate receive errors due to coupled supply noise.
TXV <sub>cc</sub>	5, 11(1, 7)	Supply	<b>Transmit V<sub>cc</sub></b> : Positive power supply required by the analog portion of the transmit circuitry. This power supply is intentionally separated from the others to prevent supply noise from coupling to the transmit outputs.
TXGND	7, 10(3, 6)	Supply	<b>Transmit GND</b> : Return path for the analog transmit power supply circuitry. This supply return is intentionally separated from others to prevent supply noise from being coupled to the transmit outputs.
EXTV <sub>cc</sub>	23(21)	Supply	<b>External V<sub>cc</sub></b> : Positive power supply for ECL output circuitry.
RXI+/-	2, 1(29, 28)	Differential Voltage In	<b>Receive Data Inputs</b> : Balanced differential line receiver inputs.
PMID+/-	25, 24(23, 22)	ECL Out	<b>Physical Media Indicate Data</b> : Differential ECL compatible outputs source the recovered receive data back to the Physical Layer device or to a separate clock recovery device.
PMRD+/-	15, 16(12,13)	ECL In	<b>Physical Media Request Data</b> : Differential ECL compatible inputs which receive data from Physical Layer Device.
TXO+/-	9, 8(5,4)	Differential Current Out	<b>Transmit Data Outputs</b> : Differential current driver outputs which drive MLT-3 encoded data over twisted pair cable. These outputs provide controlled rise and fall times designed to filter the transmitters output which helps to reduce associated EMI.
SD+/-	20, 21(18, 19)	ECL Out	<b>Signal Detect Outputs</b> : Differential ECL compatible Signal Detect outputs indicating that either a signal with the proper amplitude is present at the RXI+/- inputs or that Loopback mode has been selected.
TXREF	6(2)	Current Out	<b>Transmit Amplitude Reference</b> : Reference current pin allowing adjustment of TXO+/- transmit amplitude. By placing a resistor between this pin and GND, a reference current is setup which results in a given transmit amplitude for a given application. Refer to Functional Description in Section 3.1 for reference current equations.
ENCSEL	12(9)	CMOS In	<b>Encode Select Input</b> : The TTL compatible CMOS Encode Select input controls the encoded state of the signal at the TXO+/- outputs. A logic low level at this input causes the TXO outputs to become MLT-3 encoded with the receiver programmed to accept MLT-3 encoded data. This is the recommended mode of operation. A logic high level causes the TXO pins to output standard two-level binary code and the receiver is conditioned to receive a two-level binary signal. The DP83223V does not guarantee this mode(binary) of operation.
LBEN	19(17)	CMOS In	<b>Loopback Enable</b> : TTL compatible CMOS Loopback Enable input pin selects the internal loopback path which routes the PMRD+/- data to the PMID+/- differential outputs and forces Signal Detect true. During loopback, data present at the RXI+/- inputs is ignored. However, binary data is still transmitted by the TXO+/- outputs (regardless of the state of the ENCSEL input). Loopback mode is selected when LBEN is forced high. Normal operation occurs when LBEN is forced low.

## 2.0 Pin Description (Continued)

Symbol	Pin No PLCC(PQFP)	Type	Description
EQSEL	17(14)	3-Level Select	<b>Equalization Select:</b> This three level Equalization Select input controls the mode of receiver equalization. Forcing a median voltage level, accomplished by allowing EQSEL to float, selects the adaptive equalization mode which automatically regulates the equalization effects based on signal degradation caused by the media. The other two levels are intended as test modes and are not a guaranteed mode of operation. Forcing a voltage less than 1.5V, selects full equalization which provides fixed equalization for a maximum length of cable. Forcing a voltage greater than 3.0V turns the receive equalizer off.
$\overline{\text{CDET}}$	18(15)	CMOS In	<b>Cable Detect Bar:</b> The active low Cable Detect CMOS input is provided to support the option of external Cable Detection circuitry (wire fault). With $\overline{\text{CDET}}$ low, the transceiver functions normally. With $\overline{\text{CDET}}$ high, the signal detect output is forced low which inhibits data reception by the PHY and the PMID outputs are forced to ECL static levels. The exception is in the case of Loopback when the Signal Detect output is forced high regardless of all other conditions. Please refer to the National Semiconductor Common Magnetics application note for further detail regarding the proper use of the DP83223 in a 10/100 Ethernet application.

### 3.0 Functional Description

#### 3.1 Overview

The DP83223 transceiver consists of the major functional blocks shown in the “Block Diagram”. The Transmit section consists of an ECL input buffer for PMRD+/- and the Programmable Current Output Driver. The Programmable Current Output Driver can be configured to convert the incoming binary datastream to a current sourced MLT-3 encoded datastream.

The transmit amplitude of the signal presented at the TXO output pins can be controlled by varying the value of resistance between TXREF and GND. This TXREF resistor, R<sub>REF</sub>, sets up a reference current which determines the final output current at TXO+/- as described by:

$$I_{TXO} = \frac{20.48}{R_{REF}}$$

The following equation yields the differential peak-peak transmit voltage for a given characteristic cable impedance:

$$V_{OUTpk-pkdiff} = I_{TXO} * \frac{Z_{cable}}{2}$$

The transition times at the TXO+/- outputs are of special interest. These matched rise and fall times are digitally synthesized to reduce EMI emissions at the media interface and on the media. The controlled transition times also significantly reduce the design complexity and cost by minimizing external filtering.

The Receive section consists of the following functional blocks: a differential input Equalization Amplifier with Signal Detect circuitry, signal Comparators with Control Logic, Loopback Multiplexer Logic, and differential ECL output drivers for PMID and Signal Detect.

In adaptive or full equalization mode, as selected by the EQSEL input pin, the receive data is first equalized and then amplified for signal detection. If the receive equalizer is turned off, the data is then only amplified for signal detection.

The Comparator and Control Logic Block performs several functions. Primarily, the comparators quantize and convert incoming MLT-3 into binary. The control logic receives input from CDET and ENCSEL enabling final signal detect indication and control of data conversion/regeneration.

The Loopback Mux logic performs the function of routing the transmit data at the PMRD+/- inputs to either the PMID+/- pins (loopback enabled) or directly to the TXO+/- current outputs (normal operation).

Finally, ECL output drivers are used to drive both PMID+/- receive data and SD+/- Signal Detect data to the appropriate Physical Layer device.

#### 3.2 MLT-3 Encoding

The decision to incorporate MLT-3 (Multi-Level-Transmit / 3 levels) signal encoding into the ANSI X3.263 Twisted Pair Standard is based solely on the issue of Electro-Magnetic Compatibility (EMC). Scrambling the datastream, via the Stream Cipher function, reduces EMI emissions at key frequencies by approximately 20dB. Although 20dB is significant, it may be insufficient to pass the FCC Class B radiation limit (with margin) for NRZI signalling at the standard transmit amplitude of 2.0V. The inclusion of MLT-3

encoding theoretically provides an additional 3dB reduction in EMI emissions depending on the measurement technique and system design/layout.

The effect of MLT-3 encoding is the reduction of energy on the media in the critical frequency range of 20MHz to 100MHz. This is achieved by trading line frequency for line voltage complexity. When a binary data stream is MLT-3 encoded, the result is a shift, in part, of some frequency components of the signal.

See Figure 3-1, the second ‘high’ pulse in the binary waveform is transformed by an inversion to the ‘-1’ level in the MLT-3 waveform. This inversion corresponds to a certain decrease in energy from the original binary frequency component. The decrease in energy at the critical frequency of 62.5MHz is appreciable (3dB to 6dB).

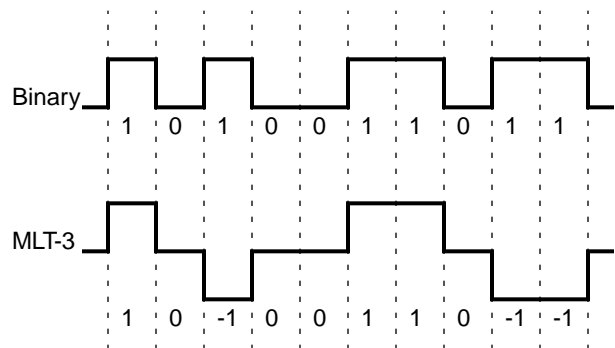

Figure 3-1. Example of Binary vs. MLT-3

The power spectrum plots in Figure 3-2 and Figure 3-3 provide a clear comparison between scrambled binary and scrambled MLT-3 respectively. It should be noted that FCC Class B limits relate to radiated emissions and not the direct power spectrum. The plots in Figure 3-2 and Figure 3-3 are intended strictly for use as a general comparison between Binary and MLT-3 and should not be interpreted as absolute EMI performance indicators.

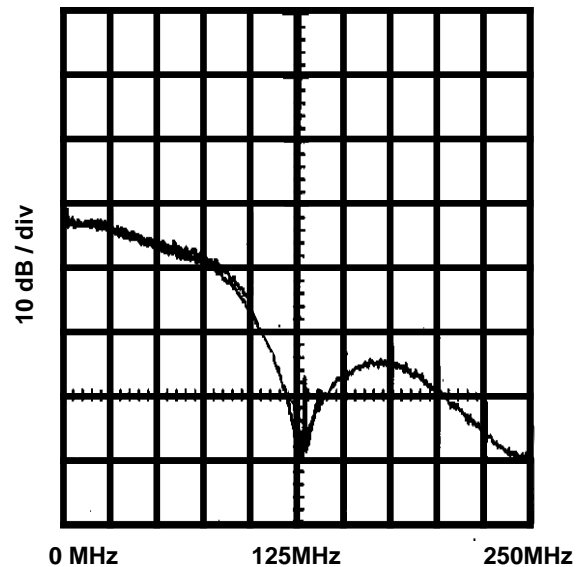

Figure 3-2. 1V Binary Power Spectrum

### 3.0 Functional Description (Continued)

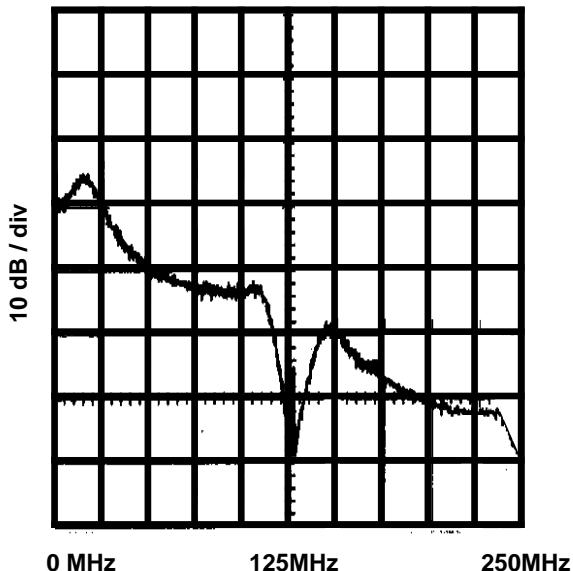

Figure 3-3. 2V MLT-3 Power Spectrum

### 3.3 Transition Time Control

The DP83223 TWISTER incorporates a unique feature which virtually eliminates the need for external filtering of the transmitted signal. The transition times of the TXO output signals are digitally synthesized resulting in closely matched and controlled rise and fall times (Refer to Figure 3-4). These controlled transition times, in conjunction with the associated magnetics, result in typical rise and fall times of greater than 3ns. These transition times lie within the range specified in the X3.263 Twisted Pair PMD standard.

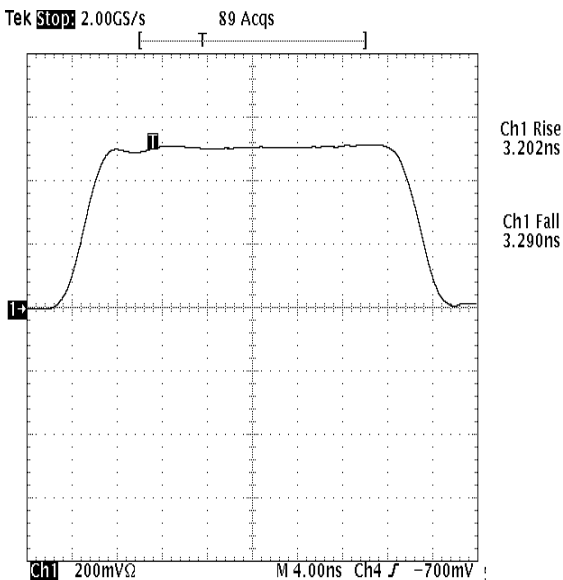

Figure 3-4. Controlled TXO Transitions

### 3.4 Adaptive Equalization

When transmitting data at high speeds over copper twisted pair cable, frequency dependent attenuation becomes a concern. In Twisted Pair Fast Ethernet or FDDI signalling the frequency content of the transmitted signal can vary greatly during normal operation based primarily on the randomness of the scrambled data stream. This variation in signal attenuation caused by frequency variations must be compensated for to ensure the integrity of the transmission.

In order to ensure quality transmission when employing MLT-3 encoding, the compensation must be able to adapt to various cable lengths and cable types depending on the installed environment. In a fixed equalization system, the selection of long cable lengths for a given implementation, requires significant compensation which will over-compensate for shorter, lower attenuation lengths. Conversely, the selection of short or intermediate cable lengths requiring less compensation will cause serious under-compensation for longer length cables. Therefore, the compensation (equalization) must be adaptive to ensure proper conditioning of the received signal independent of cable length.

The combination of choosing MLT-3 as the signal encoding scheme, in conjunction with a requirement for adaptive equalization, demands that compensation occur at the receive end of the transmission network. In order to implement receiver adaptive equalization, a known relationship between transmit output amplitude and a receive input reference must be specified and controlled. Nominal transmit output amplitude, as specified by the ANSI X3.263 TP-PMD document, is 2.0V peak to peak differential. The DP83223 TWISTER incorporates a fixed nominal receive input reference. Given these two parameters, the adaptive equalization can determine the approximate cable length via signal attenuation at certain frequencies and actively compensate for cable length variations.

Since the DP83223 TWISTER transceiver's receive input reference is fixed at approximately 1.45V and the transmit amplitude is fixed at 2.0V, an attenuation factor is required. This attenuation is accomplished by a simple resistive voltage divider placed at the RXI+/- inputs, which also serves as the forward termination for the transmission line (Refer to Figure 4-3). Because the voltage divider attenuates any noise along with the received signal, the Signal-to-Noise ratio is not decreased. An additional benefit is gained by including the voltage divider, where any insertion loss caused by the media coupling magnetics can be compensated for by adjusting the voltage divider ratio. This will ensure appropriate signal transfer and optimal adaptive equalization.

For additional information regarding the interdependencies between the adaptive equalizer and the receive attenuation/termination circuit, refer to the NSC application note entitled "DP83223 Adaptive Equalizer Considerations".

### 3.5 Jitter Performance

This section briefly presents the typical jitter performance exhibited by the DP83223 TWISTER transceiver. The DP83223 TWISTER was subjected to the near worst-case condition of 110 Meters of Category 5 cable connected to two lengths of 10Meter cable via two 110 punchdown blocks (totalling 130 Meters). The DP83223

### 3.0 Functional Description (Continued)

TWISTER was loaded with pseudo random data (PRBS-23) approximating actual packet data encrypted via the stream cipher algorithm. The typical peak-peak total jitter resulting from the combination of the transmitter, cable plant, and receiver is only 1.9ns Pk-Pk (MLT-3, room temp., nominal Vcc) as illustrated in Figure 3-5. Because the maximum eye opening is 8ns, The DP83223 has little impact on the total jitter budget.

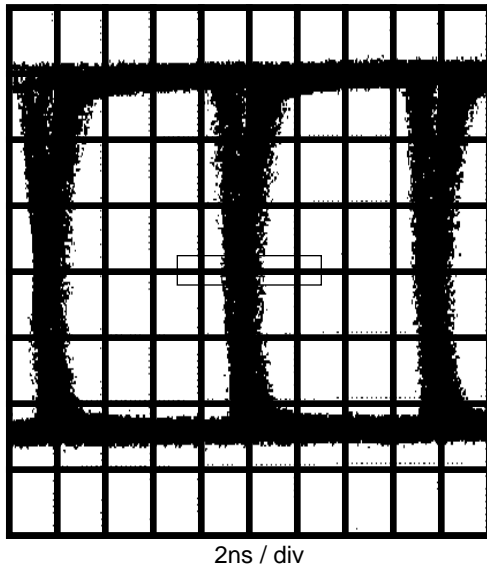

Figure 3-5. MLT-3 Total Jitter=1.9ns Pk-Pk

## 4.0 DC and AC Specifications

### Absolute Maximum Ratings

Supply Voltage ( $V_{CC}$ )	-0.5 V to 7.0 V
Received Power ( $RXV_{CCV}$ )	-0.5 V to 7.0 V
Transmitted Power ( $RXV_{CCV}$ )	-0.5 V to 7.0 V
Storage Temperature Range ( $T_{STG}$ )	-65°C to 150°C
Power Dissipation ( $P_D$ )	1.575 W
$I_{ECI}$	-50 mA
Lead Temp. ( $T_L$ ) (Soldering, 10 sec)	260°C

ESD Rating  
( $R_{ZAP} = 1.5k$ ,  $C_{ZAP} = 120$  pF) 2.0 KV

### Recommended Operating Conditions

Supply voltage ( $V_{DD}$ )	5 Volts $\pm$ 5%
Ambient Temperature ( $T_A$ )	0 to 70 °C

Note: Absolute maximum ratings are those values beyond which the safety of the device cannot be guaranteed. They are not meant to imply that the device should be operated at these limits.

### DC Specifications $T_A = 0^\circ\text{C}$ to $70^\circ\text{C}$ , $V_{CC} = 5$ V 5%, unless otherwise specified

Symbol	Parameter	Conditions	Min	Max	Units	
$I_{IHt}$	TTL High Level Input	$V_{IN} = V_{CC}$		10	$\mu\text{A}$	
$I_{ILt}$	TTL Low Level Input	$V_{IN} = \text{GND}$		-10	$\mu\text{A}$	
$I_{IH\overline{\text{cdet}}}$	$\overline{\text{CDET}}$ High Level Input	$V_{IN} = V_{CC}$		10	$\mu\text{A}$	
$I_{IL\overline{\text{cdet}}}$	$\overline{\text{CDET}}$ Low Level Input	$V_{IN} = \text{GND}$		-10	$\mu\text{A}$	
$I_{IH\text{eqsel}}$	EQSEL High Level Input	$V_{IN} = V_{CC}$		800	$\mu\text{A}$	
$I_{IL\text{eqsel}}$	EQSEL Low Level Input	$V_{IN} = \text{GND}$		-800	$\mu\text{A}$	
$I_{IH\text{e}}$	ECL High Level Input	$V_{IN} = V_{CC} - 830$ mV		50	$\mu\text{A}$	
$I_{IL\text{e}}$	ECL Low Level Input	$V_{IN} = V_{CC} - 1570$ mV		1	$\mu\text{A}$	
$V_{IHt}$	TTL High Level Input		2		V	
$V_{ILt}$	TTL Low Level Input			0.8	V	
$V_{IH\overline{\text{cdet}}}$	$\overline{\text{CDET}}$ High Level Input	note 2	$V_{CC}-1$		V	
$V_{IL\overline{\text{cdet}}}$	$\overline{\text{CDET}}$ Low Level Input	note 2		1	V	
$V_{IH\text{eqsel}}$	EQSEL Mid Level Input	note 3		$V_{CC} / 2$	V	
$V_{IH\text{e}}$	ECL High Level Input		$V_{CC}-1165$	$V_{CC}-880$	mV	
$V_{IL\text{e}}$	ECL Low Level Input		$V_{CC}-1810$	$V_{CC}-1475$	mV	
$V_{OH\text{e}}$	ECL High Level Output		$V_{CC}-1075$	$V_{CC}-830$	mV	
$V_{OL\text{e}}$	ECL Low Level Output		$V_{CC}-1860$	$V_{CC}-1570$	mV	
$I_{CC}$	Dynamic Supply Current	notes 4 & 5, Figure 4-1		135	mA	
$I_{TXO}$	Transmit Current	note 6, Figure 4-1	38.2	40	41.8	mA
$I_{TX-O\text{match}}$	Transmit Current Matching	note 7, Figure 4-1	-2	2	%	
$SD_{THon}$	Sig Det Assert Threshold	note 8, Figure 4-2		700	mV	
$SD_{THoff}$	Sig Det De-assert Threshold	notes 1 & 9, Figure 4-2	200		mV	
$R_{IN\text{diff}}$	RXI differential input resistance		7	9	$K\Omega$	

### 4.0 DC and AC Specifications (Continued)

**Note 1:** Guaranteed by characterization over process, temperature, and Vcc.

**Note 2:** It is recommended that the  $\overline{CDET}$  control input be tied directly to Vcc or GND to ensure proper operation. If  $\overline{CDET}$  is to be driven from a gate, it is recommended that the gate be capable of true CMOS logic levels.

**Note 3:** The median voltage level for EQSEL is normally accomplished by floating that pin.

**Note 4:** ICC is a measure of total device current in normal MLT-3 mode with a 125Mb/s random data pattern applied to the PMRD+/- inputs to allow the TXO+/- outputs to switch at a nominal 2V pk-pk differential amplitude into a standard 50Ω differential load. ICC is minus the current through the PECL inputs. Device configuration: LBEN=0,  $\overline{CDET}$ =0, ENCSEL=0, EQSEL=float, PMRD+/-=125Mb/s data, RXI+/-=125Mb/s data.

**Note 5:** ICC does not include the current through the PECL outputs. Standard 50Ω Thevenin equivalent PECL terminations (figure 10) require approximately 14 mA per pin, or a total of 56 mA. 100Ω PECL terminations require approximately 7 mA per pin, or a total of 28 mA. These external PECL termination current requirements should be considered when analyzing system power requirements.

**Note 6:** TXO output current is a measure of the total differential current present at the TXO+/- outputs into a standard 50Ω differential load. Device configuration: RREF =510Ω, LBEN=0,  $\overline{CDET}$ =0, ENCSEL=0, EQSEL=float, RXI+/-=static.

**Note 7:**  $I_{TXOmatch}$  refers to the percentage of mismatch in current between TXO+ and TXO- referenced to the total output current as defined by:

$$I_{TXOmatch} = \frac{I_{TXO+} - I_{TXO-}}{I_{TXO+} + I_{TXO-}} \times 100$$

Device configuration: RREF =510Ω, ENCSEL=0, PMRD+=0, PMRD-=1.

**Note 8:** Signal Detect Assert Threshold is a measure of the pk-pk differential signal amplitude at the RXI+/- inputs of the RJ45 required to cause the Signal Detect differential output to assert. Device configuration: LBEN=0,  $\overline{CDET}$ =0, ENCSEL=0, EQSEL=float, PMRD+/-=static, RXI+/-=125Mb/s data with swept amplitude.

**Note 9:** Signal Detect De-assert Threshold is a measure of the pk-pk differential signal amplitude at the RXI+/- inputs of the RJ45 required to cause the Signal Detect differential output to de-assert. Device configuration: LBEN=0,  $\overline{CDET}$ =0, ENCSEL=0, EQSEL=float, PMRD+/-=static, RXI+/-=125Mb/s data with swept amplitude

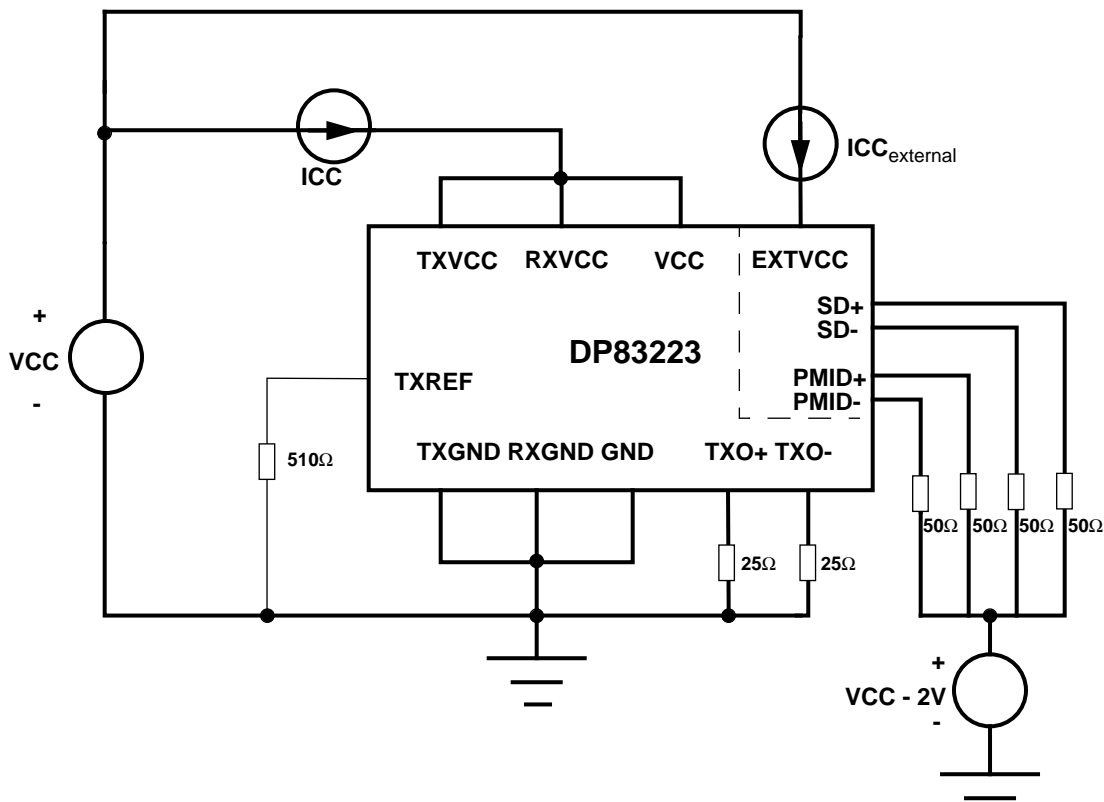

Figure 4-1. ICC / Load Diagram

4.0 DC and AC Specifications (Continued)

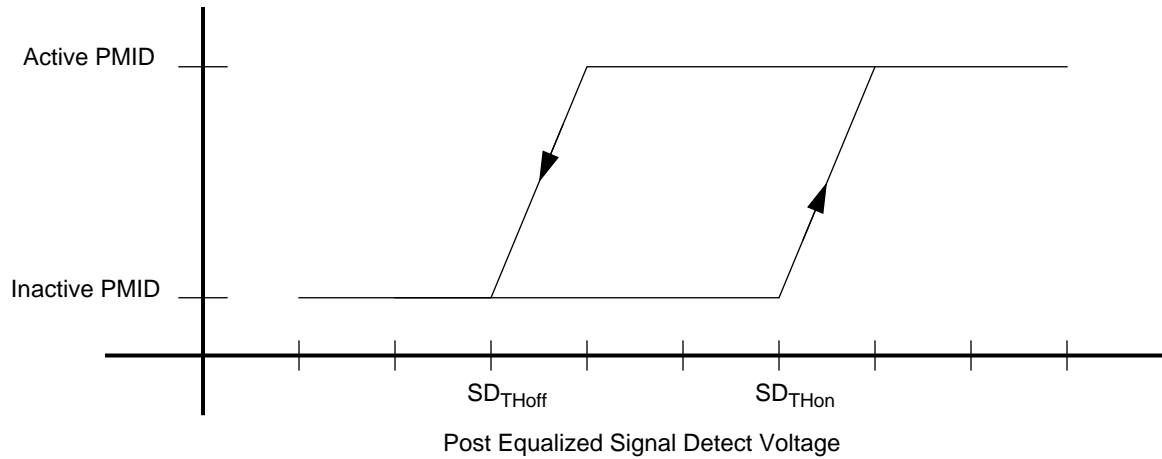
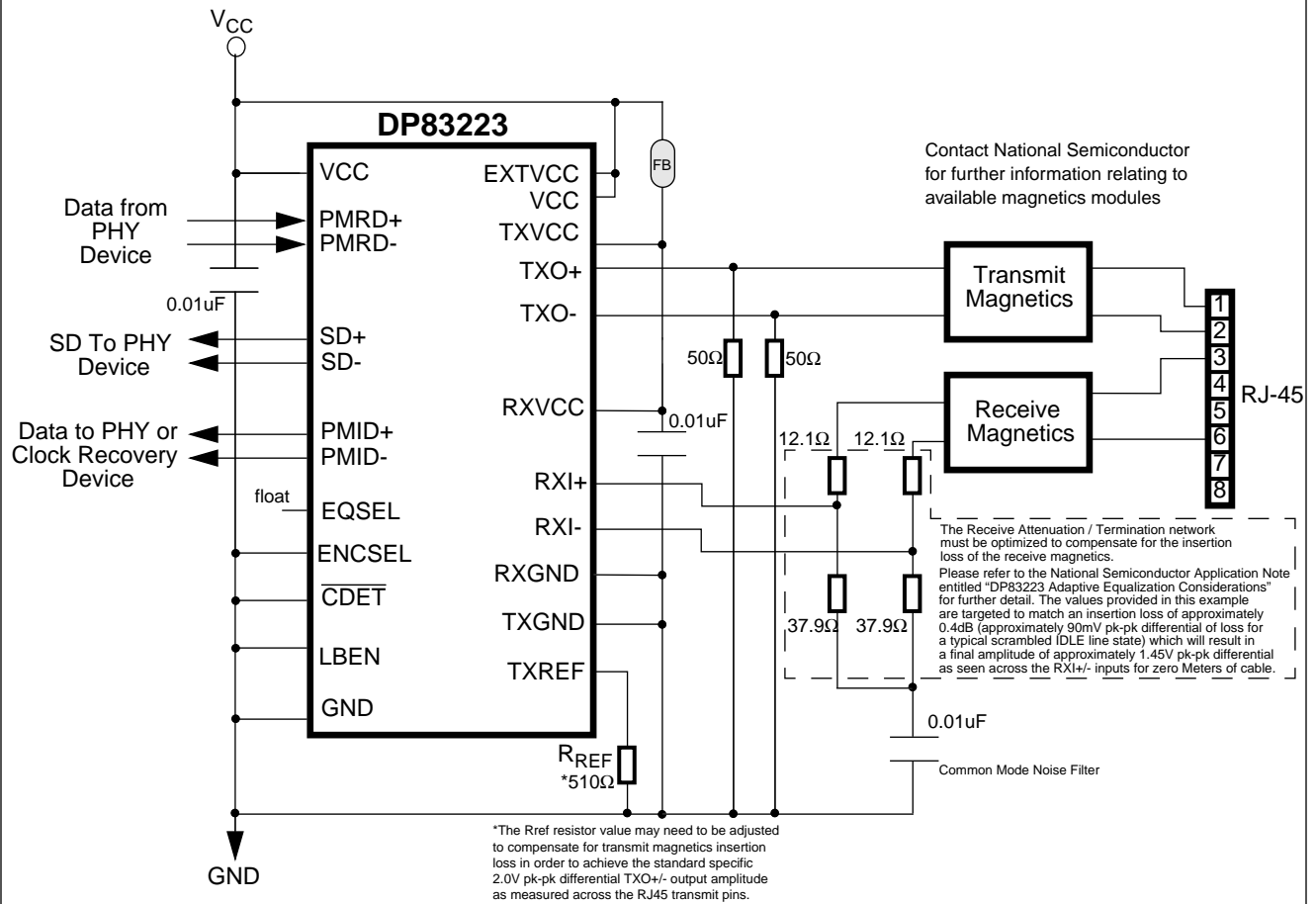

Figure 4-2. Post Equalized Signal Detect Voltage



The PMRD, SD and PMID 100K ECL differential signal must be terminated into a standard ECL load of 50Ω to VCC-2.0V or equivalent: i.e. Thevenin of 130Ω to GND accompanied by 82Ω to VCC

All resistors are 1/10th Wt, 1% tolerance  
All capacitors are 16V ceramic

FB = Murata # BLM31A02PT (1206 package)

Figure 4-3. Typical Schematic for 100BASE-TX signalling over Cat-5 UTP 100Ω cable

## 4.0 DC and AC Specifications (Continued)

### 4.1 TRANSMIT TIMING

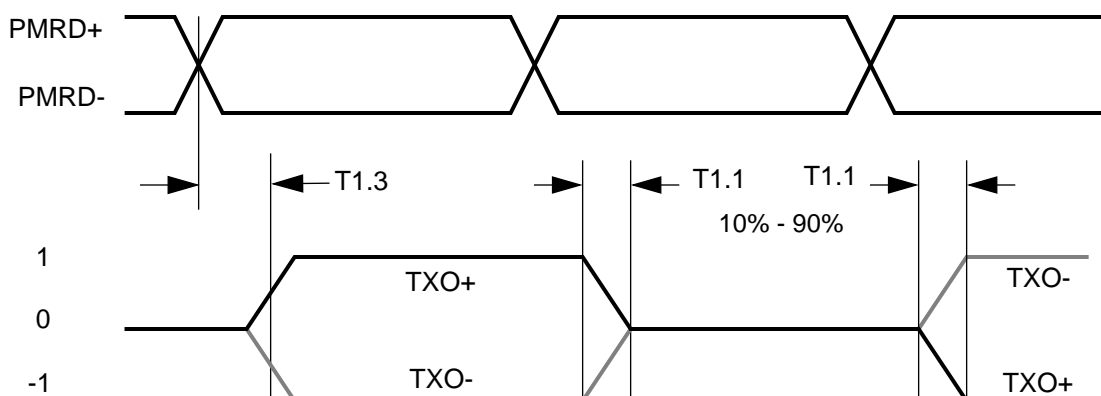

Number	Parameter	Min	Typ	Max	Units
T1.1	TXO Output Rise and Fall	2.25	2.75	3.25	ns
T1.2	TXO Rise / Fall Symmetry			500	ps
T1.3	TX prop delay		7		ns
T1.4	Transmit Jitter			1.4	ns

**Note:** TXO Output Rise and Fall time is a measure of the transition time for all MLT-3 transitions from 10% to 90%. This measurement is conducted directly at the TXO+/- outputs and does not include the additional bandwidth limiting effects of an isolation transformer. Each of the four possible MLT-3 transitions is measured (see figure 2 for MLT-3 waveform example). The TXO+/- outputs are configured to switch at a nominal 2V pk-pk differential amplitude into a standard 50Ω differential load. Device configuration: LBEN=0, CDET=0, ENCSEL=0, EQSEL=float, PMRD+/-=125Mb/s data, RXI+/-=static.

**Note:** :  $t_{TXr/fsym}$  TXO Rise and Fall Symmetry is the difference between the maximum and minimum of all rise and fall times. Device configuration: LBEN=0, CDET=0, ENCSEL=0, EQSEL=float, PMRD+/-=125Mb/s data, RXI+/-=static.

**Note:** : The Transmit channel propagation delay is a measure of the time delay imposed on the transmit data as it passes from the PMRD+/- inputs to the TXO+/- outputs. Device configuration: LBEN=0, CDET=0, ENCSEL=0, EQSEL=float, PMRD+/-=125Mb/s data, RXI+/-=static.

**Note:** Transmit Jitter is a measure of the total jitter as measured differentially across the TXO+/- outputs of the device. This includes the cumulative effect of Duty Cycle Distortion (DCD), Data Dependent Jitter (DDJ), and Random Jitter (RJ). Device configuration: LBEN=0, CDET=0, ENCSEL=0, EQSEL=float, PMRD+/-=125Mb/s data (pseudo random <sup>15</sup>), RXI+/-=125Mb/s data in order to induce a worst case system level noise environment.

**Note:** T1.1, T1.2 and T1.4 are guaranteed by characterization over process, temperature, and Vcc.

### 4.2 RECEIVE PROPAGATION DELAY

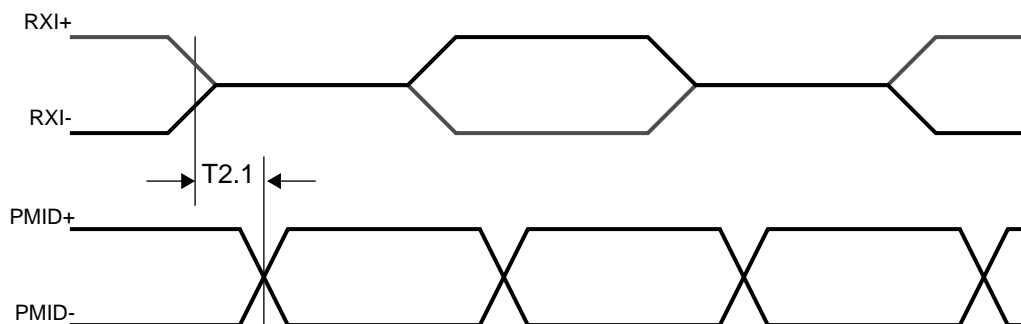

Number	Parameter	Min	Typ	Max	Units
T2.1	Receive Propagation Delay		7		ns

**Note:** The Receive channel propagation delay is a measure of the time delay imposed on the receive data as it passes from the RXI+/- inputs to the PMID+/- outputs. This measurement is taken after the device has had sufficient time for the receive adaptive equalizer to converge. Device configuration: LBEN=0, CDET=0, ENCSEL=0, EQSEL=float, PMRD+/-=static, RXI+/-=125Mb/s data.

### 4.3 LOOPBACK PROPAGATION DELAY

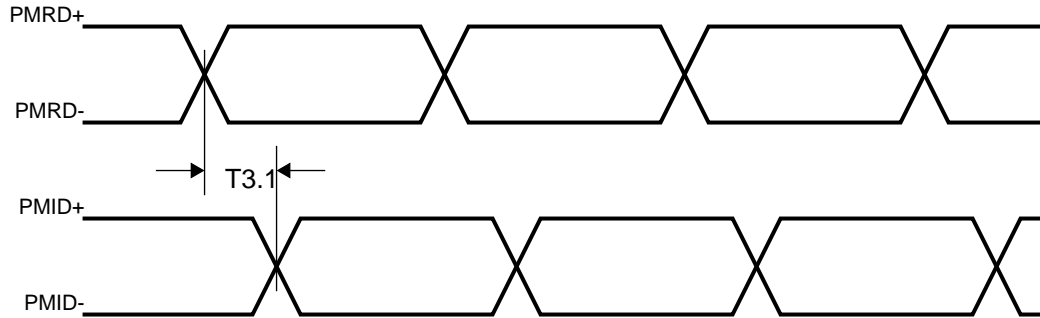

Number	Parameter	Min	Typ	Max	Units
T3.1	Loopback Propagation Delay		7		ns

### 4.4 SIGNAL DETECT TIMING

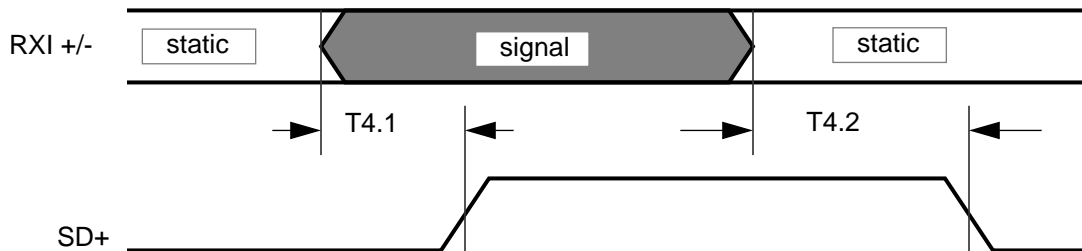

Number	Parameter	Min	Typ	Max	Units
T4.1	Signal Detect Turn-On Time		40	100	us
T4.2	Signal Detect Turn-Off Time		12	50	us

**Note:** The Signal Detect Assert Time is a measure of the time required for Signal Detect to assert after the RXI+/- inputs are provided with a receive signal with sufficient amplitude to meet the Signal Detect Assert Threshold parameter. Device configuration: LBEN=0, CDET=0, ENCSEL=0, EQSEL=float, PMRD+/-=static, RXI+/-=125Mb/s data with amplitude greater than 700mV pk-pk differential.

**Note:** The Signal Detect De-assert Time is a measure of the time required for Signal Detect to deassert after the RXI+/- inputs are provided with a receive signal with sufficient amplitude to meet the Signal Detect Deassert Threshold parameter. Device configuration: LBEN=0, CDET=0, ENCSEL=0, EQSEL=float, PMRD+/-=static, RXI+/-=125Mb/s data with amplitude less than 200mV pk-pk differential.

### 4.5 ADAPTIVE EQUALIZER TIMING

Number	Parameter	Min	Typ	Max	Units
T5.1	Total Jitter (TX+RX)		2	3.5	ns

**Note:** Total Receive Jitter is a measure of the total accumulated jitter as measured differentially across the PMID+/- receive outputs of the device. This parameter is guaranteed by an ATE adaptive equalizer jitter measurement (done at worst case conditions) and a system level characterization over temperature and Vcc. The ATE measurement has been empirically correlated with the system level jitter measurement, which includes all transmit jitter (as described in T1.3) as well as all jitter induced by a worst case Cat-5 cable plant and the additional Jitter induced by the receive operation of the device. Device configuration: LBEN=0, CDET=0, ENCSEL=0, EQSEL=float, PMRD+/-=125Mb/s data, RXI+/-=125Mb/s data.

## LIFE SUPPORT POLICY

NATIONAL'S PRODUCTS ARE NOT AUTHORIZED FOR USE AS CRITICAL COMPONENTS IN LIFE SUPPORT DEVICES OR SYSTEMS WITHOUT THE EXPRESS WRITTEN APPROVAL OF THE PRESIDENT OF NATIONAL SEMICONDUCTOR CORPORATION. As used herein:

1. Life support devices or systems we do or systems which, (a) are intended for surgical implant into the body, or (b) support or sustain life, and whose failure to perform, when properly used in accordance with instructions for use provided in the labeling, can be reasonably expected to result in a significant injury to the user.
2. A critical component is any component of a life support device or system whose failure to perform can be reasonably expected to cause the failure of the life support device or system, or to affect its safety or effectiveness.



**National Semiconductor Corporation**

1111 West Bardin Road  
Arlington, TX 76017

Tel: 1(800) 272-9959

Fax: 1(800) 737-7018

**National Semiconductor Corporation Europe**

Fax: (+49) 0-180-530 85 86

Email: cnjwge@tevm2.nsc.com

Duetsch Tel: (+49) 0-180-530 85 86

English Tel: (+49) 0-180-532 78 32

Francais Tel: (+49) 0-180-532 93 58

Italiano Tel: (+49) 0-180-534 16 80

**National Semiconductor Corporation Japan Ltd.**

Tel: 81-043-299-2308

Fax: 81-043-299-2408

**National Semiconductor Corporation Hong Kong Ltd.**

13th Floor, Straight Block,  
Ocean Centre, 5 Canton Rd.  
Tsimshatsui, Kowloon  
Hong Kong  
Tel: (852) 2737-1600  
Fax: (852) 2736-9960

# National Semiconductor was acquired by Texas Instruments.

[http://www.ti.com/corp/docs/investor\\_relations/pr\\_09\\_23\\_2011\\_national\\_semiconductor.html](http://www.ti.com/corp/docs/investor_relations/pr_09_23_2011_national_semiconductor.html)

This file is the datasheet for the following electronic components:

DP83223V - <http://www.ti.com/product/dp83223v?HQS=TI-null-null-dscatalog-df-pf-null-ww>



LittleDiode supplies new, hard to find or obsolete electronic components and semiconductors all over the world.

With over two million different components listed you are sure to find the part you need.

Feel free to visit us today at our online store:

[LittleDiode.com](http://LittleDiode.com)

Looking forward to providing you with the best possible service.