

FAN7601

Green Current Mode PWM Controller

Features

- Green Current Mode PWM Control
- Low Operating Current: Max 4mA
- Burst Mode Operation
- Internal High Voltage Start-up Switch
- Under Voltage Lockout (UVLO): 12V/8V
- Latch Protection & Soft Start Function
- Over Voltage Protection: 19V
- Operating Frequency up to 300kHz
- Max Duty Cycle: 95%

Typical Applications

- Off-Line Adapter Applications
- Auxiliary Power Supplies

Description

The FAN7601 is a green programmable frequency current mode PWM controller. It is specially designed for the off-line adapter application and the auxiliary power supplies which require high efficiency at a light load and no load. The internal high voltage start-up switch and the burst mode reduce the power loss. The FAN7601 includes some protections such as latch protection and over voltage protection. The latch protection can be used for over voltage protection and/or thermal protection and so on. And the soft start prevents the output voltage over shoot at start up.

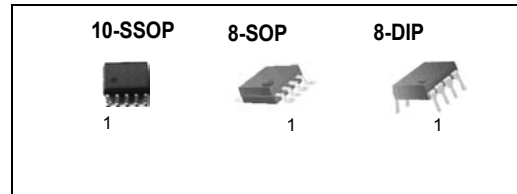

Internal Block Diagram

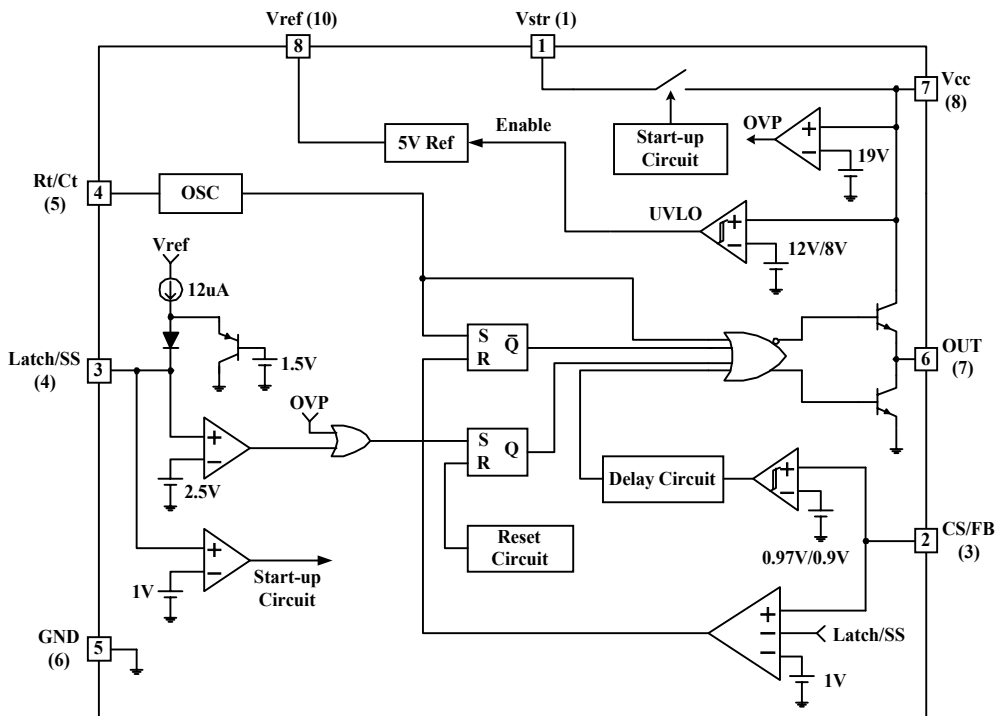

* () is 10-SSOP PIN Number

Pin Assignments

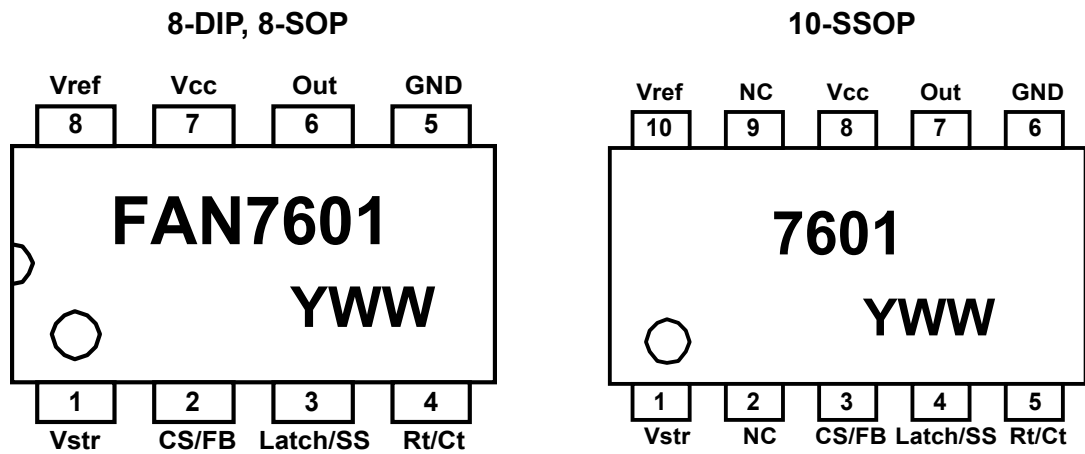

Pin Definitions

| Pin Number | Pin Name | Pin Function Description |
|------------|----------|---------------------------------|
| 1 (1) | Vstr | Start-up |
| 2 (3) | CS/FB | Current Sense and Feedback |
| 3 (4) | Latch/SS | Latch Protection and Soft Start |
| 4 (5) | Rt/Ct | Oscillator Timing |
| 5 (6) | GND | Ground |
| 6 (7) | Out | Gate Drive Output |
| 7 (8) | VCC | IC Power Supply |
| 8 (10) | Vref | Voltage Reference |

*() is 10-SSOP PIN Number

Absolute Maximum Ratings

(Ta = 25°C, unless otherwise specified)

| Characteristics | Symbol | Value | Unit |
|---|---------|-------------|------|
| Supply Voltage | VCC | 20 | V |
| Input Voltage CS/FB | VCS/FB | -0.3 to 20 | V |
| Operating Temperature | TOPR | -25 to +125 | °C |
| Storage Temperature | TSTG | -55 to +150 | °C |
| Junction Temperature | Tj | 150 | °C |
| Output Current | IO | 250 | mA |
| Vstr Input Voltage | Vstr | 500 | V |
| ESD Capability, HBM Model (All pins except Vcc and Vstr) | - | 2.0 | kV |
| ESD Capability, Machine Model | - | 300 | V |
| Thermal Resistance, Junction to Air | 8-DIP | 100 | °C/W |
| | 8-SOP | 180 | |
| | 10-SSOP | 130 | |

Electrical Characteristics

($T_a = -25^{\circ}\text{C} \sim 125^{\circ}\text{C}$, $V_{CC} = 14\text{V}$, $R_t = 9.5\text{k}\Omega$, $C_t = 2.2\text{nF}$ unless otherwise specified)

| Characteristics | Symbol | Conditions | Min. | Typ. | Max. | Unit |
|---|-------------------|---|------|------|------|---------------|
| REFERENCE SECTION | | | | | | |
| Reference Output Voltage | V_{ref} | $I_O = 1\text{mA}$ | 4.85 | 5.00 | 5.15 | V |
| Line Regulation | ΔV_{ref1} | $V_{CC} = 10\text{V} \sim 18\text{V}$ | - | 10 | 20 | mV |
| Load Regulation | ΔV_{ref2} | $I_O = 1\text{mA} \sim 10\text{mA}$ | - | 20 | 30 | mV |
| OSCILLATOR SECTION | | | | | | |
| Initial Accuracy | FOSC | - | 90 | 100 | 110 | kHz |
| Voltage Stability | STV | $V_{CC} = 10\text{V} \sim 18\text{V}$ | - | 1.0 | 1.5 | % |
| Amplitude | VOCS | V_{pin4} peak-to-peak | - | 1.25 | - | V |
| PWM SECTION | | | | | | |
| CS/FB Threshold Voltage1 | VCS/FB1 | - | 0.9 | 1.0 | 1.1 | V |
| Maximum Duty Cycle | DMAX | $T_a = 25^{\circ}\text{C}$ | 92 | 95 | 98 | % |
| Minimum Duty Cycle | DMIN | - | - | - | 0 | % |
| BURST MODE SECTION | | | | | | |
| CS/FB Threshold Voltage2 ⁽¹⁾ | VCS/FB2 | - | 0.77 | 0.97 | 1.17 | V |
| CS/FB Threshold Voltage3 ⁽¹⁾ | VCS/FB3 | - | 0.7 | 0.9 | 1.1 | V |
| SOFT START SECTION | | | | | | |
| Soft Start Current | ISS | $V_{pin3} = \text{GND}$ | 9 | 12 | 15 | μA |
| Soft Start Limit Voltage | VSL | $I_{SS} = 1\mu\text{A}$ | 1.2 | 1.5 | 1.8 | V |
| PROTECTION SECTION | | | | | | |
| Latch Voltage | VLATCH | - | 2.25 | 2.5 | 2.75 | V |
| Over Voltage Protection | VOVP | - | 18 | 19 | 20 | V |
| UVLO SECTION | | | | | | |
| Start Threshold Voltage | V_{tH} | - | 11 | 12 | 13 | V |
| Minimum Operating Voltage | V_{tL} | - | 7 | 8 | 9 | V |
| TOTAL CURRENT SECTION | | | | | | |
| Operating Supply Current | IOP | - | - | 3 | 4 | mA |
| OUTPUT SECTION | | | | | | |
| Low Output Voltage | VOL | $T_a = 25^{\circ}\text{C}$, $I_O = 100\text{mA}$ | - | 2 | 2.5 | V |
| High Output Voltage | VOH | $T_a = 25^{\circ}\text{C}$, $I_O = -100\text{mA}$ | 11.5 | 12 | 14 | V |
| Rising Time ⁽¹⁾ | T_r | $T_a = 25^{\circ}\text{C}$, $C_l = 1\text{nF}$ | - | 45 | 150 | ns |
| Falling Time ⁽¹⁾ | T_f | $T_a = 25^{\circ}\text{C}$, $C_l = 1\text{nF}$ | - | 35 | 150 | ns |
| START UP SECTION | | | | | | |
| VSTR Start-up Current | Istr | $V_{str} = 30\text{V}$, $T_a = 25^{\circ}\text{C}$ | 0.5 | 1 | 1.5 | mA |

Note:

1. These parameters, although guaranteed, are not 100% tested in production.

Typical Performance Characteristics

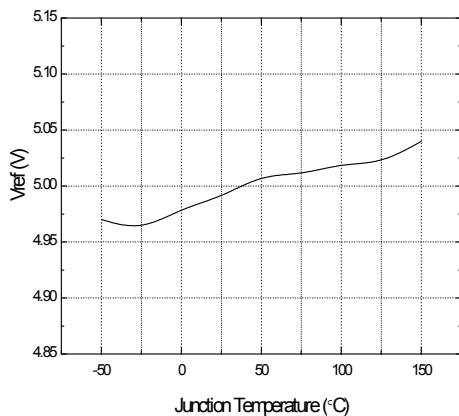

Figure 1. Trimmed Reference Voltage

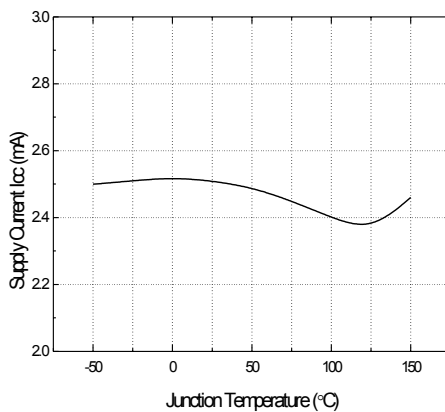

Figure 2. Supply Current

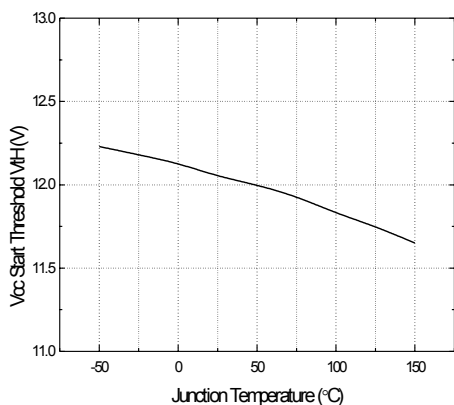

Figure 3. Vcc Start Threshold Voltage

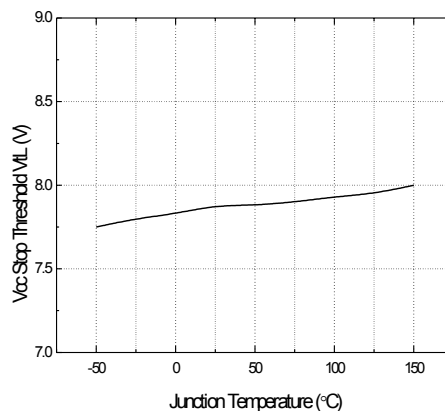

Figure 4. Vcc Stop Threshold Voltage

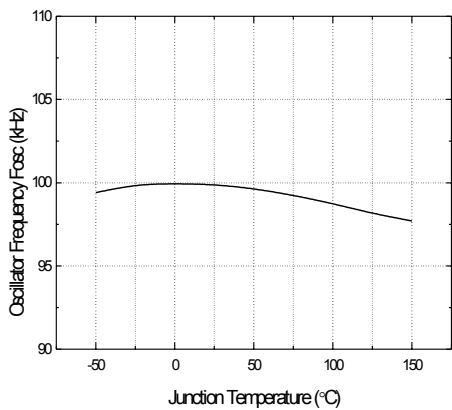

Figure 5. Oscillator Frequency

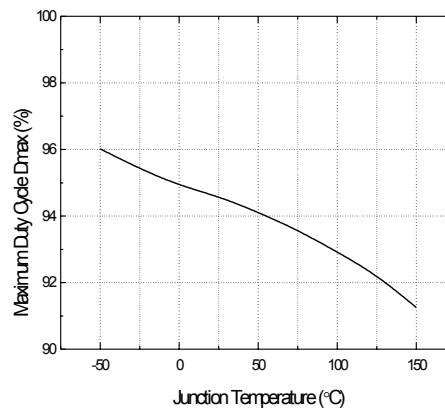

Figure 6. Maximum Duty Cycle

Typical Performance Characteristics (Continued)

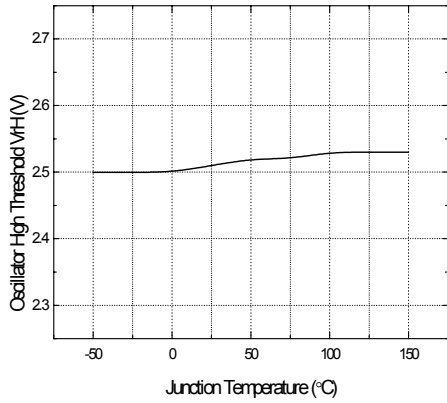

Figure 7. Oscillator High Threshold Voltage

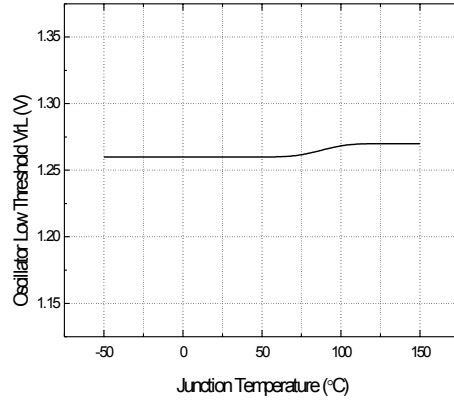

Figure 8. Oscillator Low Threshold Voltage

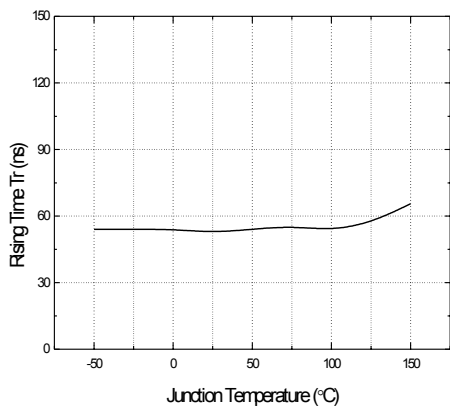

Figure 9. Output Rising Time

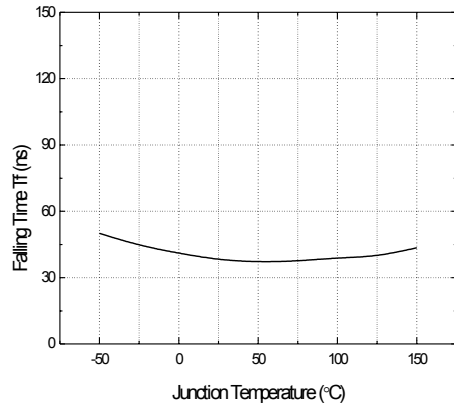

Figure 10. Output Falling Time

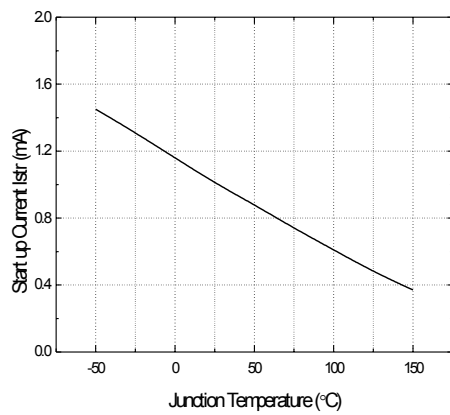

Figure 11. Start-up Current

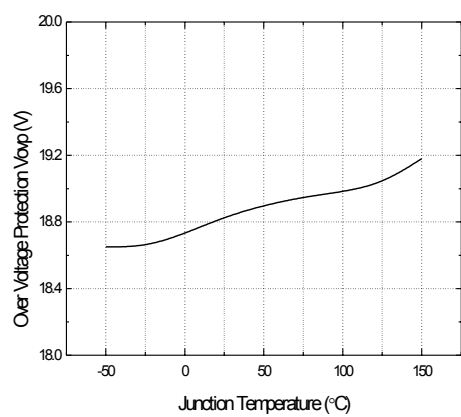

Figure 12. Over Voltage Protection Level

Typical Performance Characteristics (Continued)

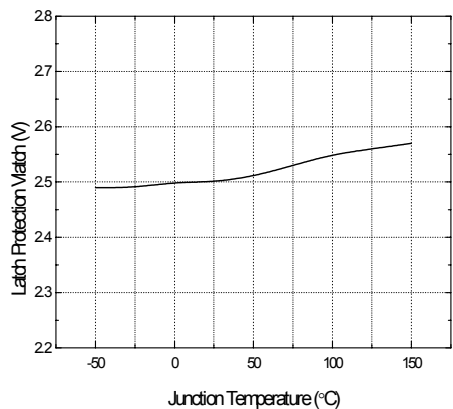

Figure 13. Latch Protection Voltage

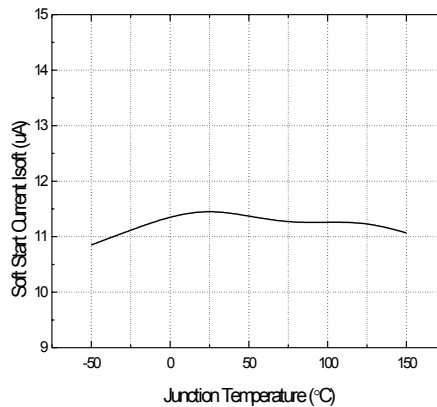

Figure 14. Soft Start Current

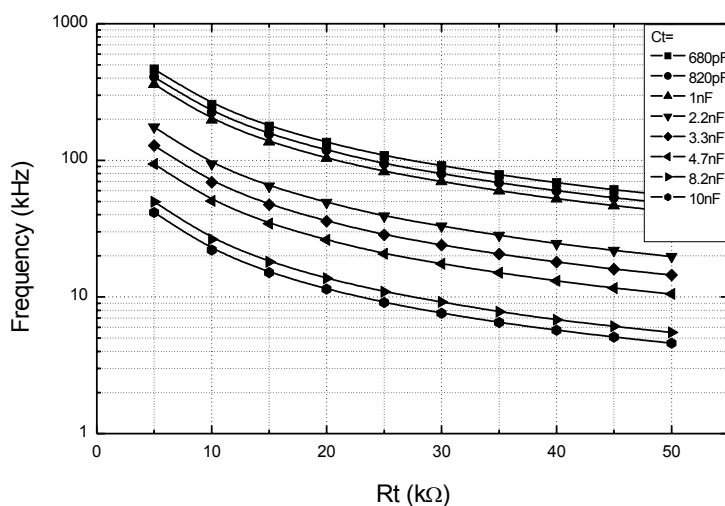
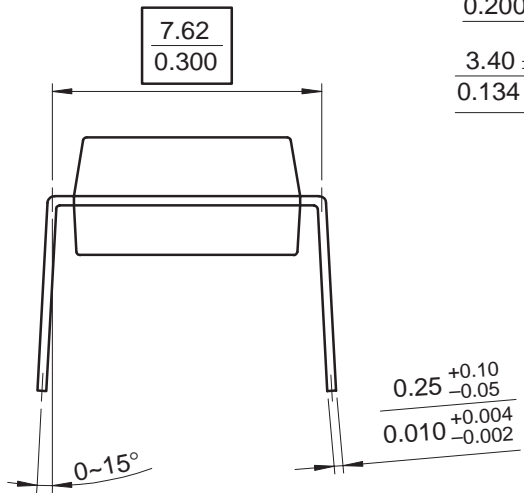
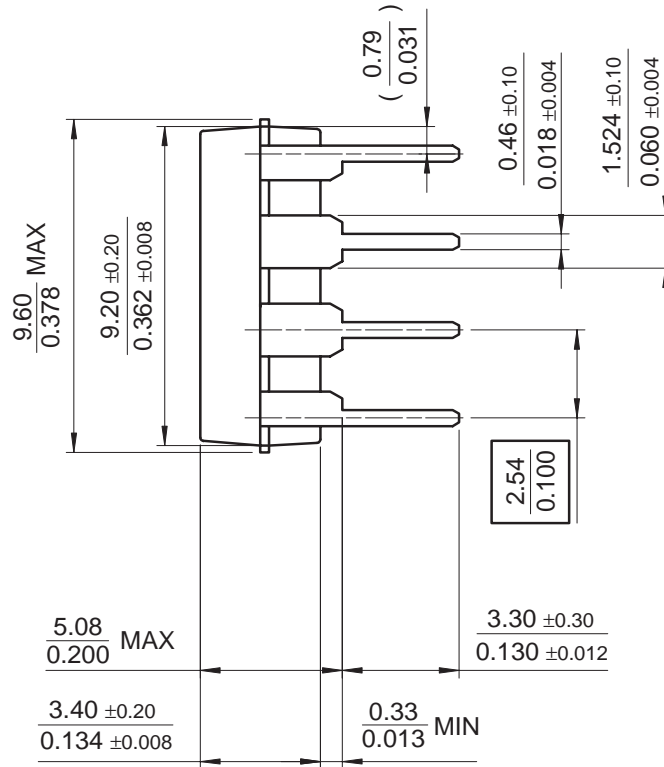
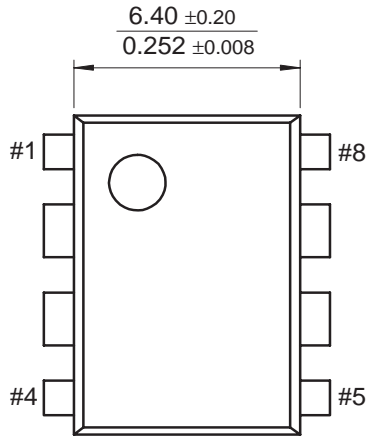

Figure 15. Oscillator Frequency Characteristic

Mechanical Dimensions (Unit: mm)

Package

8-DIP



Mechanical Dimensions (Unit: mm) (Continued)

Package

8-SOP

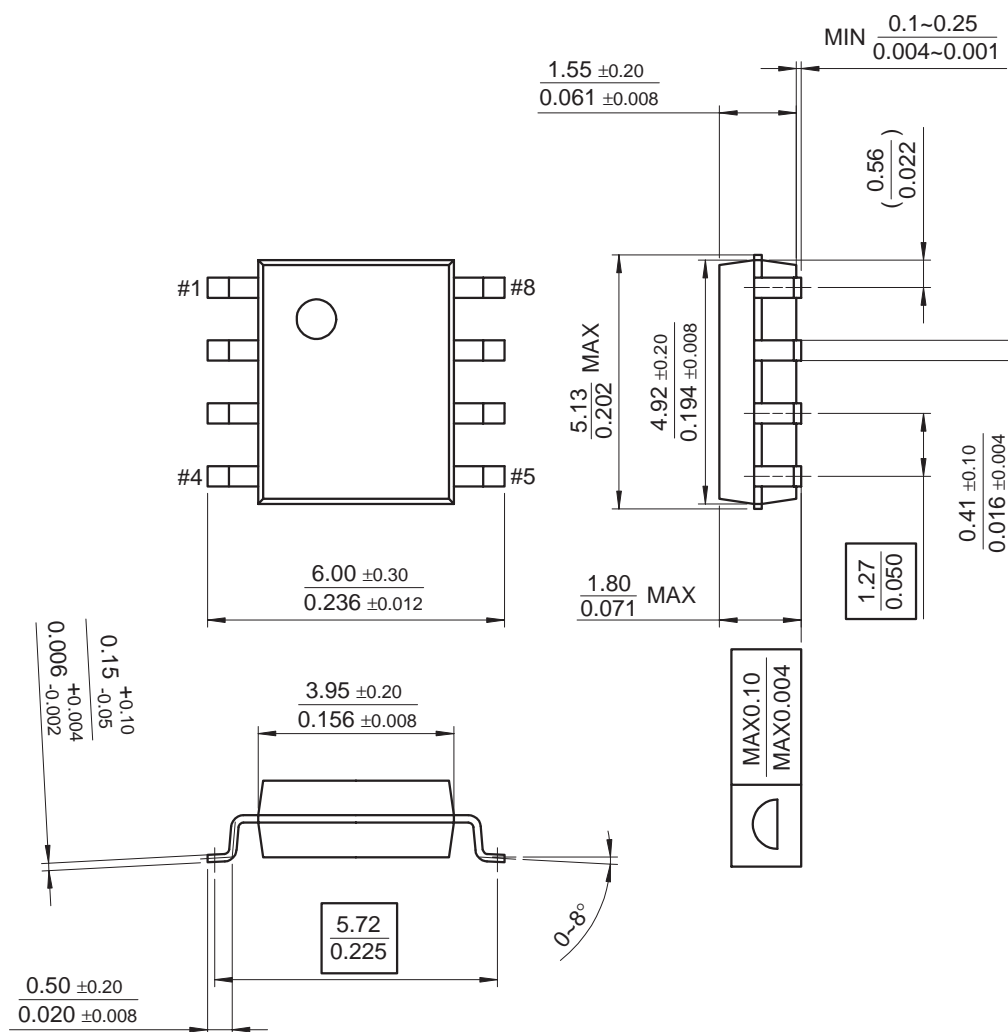

Mechanical Dimensions (Unit: mm) (Continued)

Package

10-SSOP-225

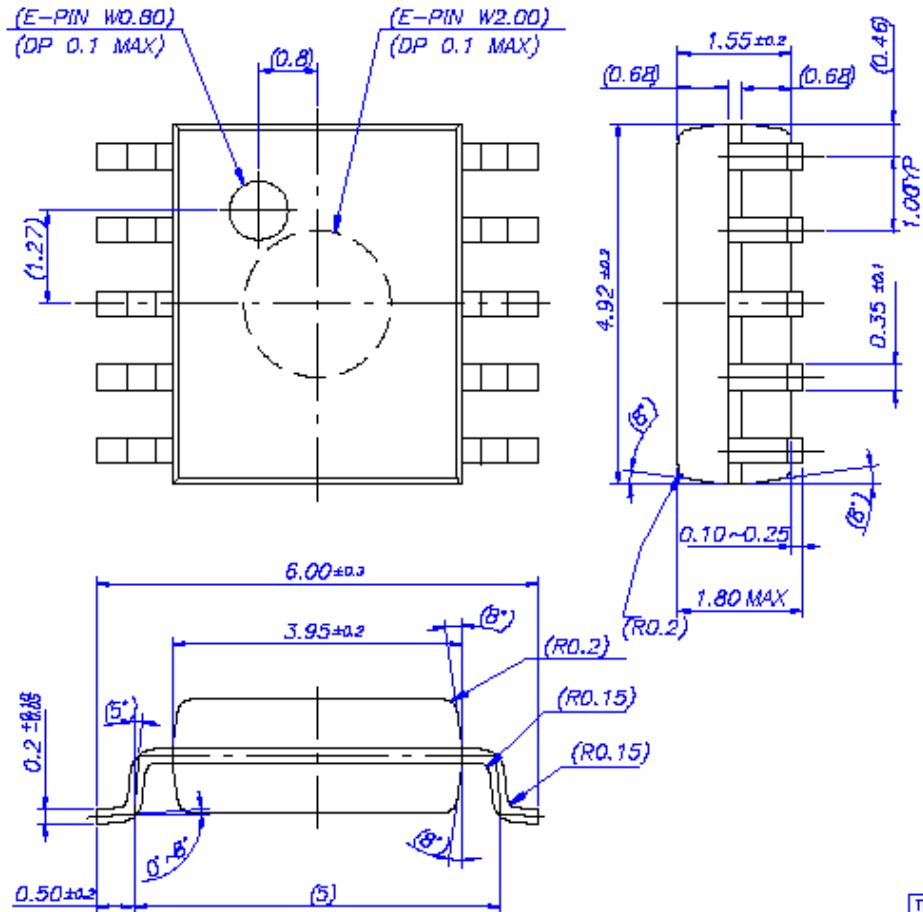

≡

Ordering Information

| Device | Package | Operating Temp. |
|----------|---------|-----------------|
| FAN7601N | 8-DIP | -25°C ~ 125°C |
| FAN7601M | 8-SOP | |
| FAN7601G | 10-SSOP | |

DISCLAIMER

FAIRCHILD SEMICONDUCTOR RESERVES THE RIGHT TO MAKE CHANGES WITHOUT FURTHER NOTICE TO ANY PRODUCTS HEREIN TO IMPROVE RELIABILITY, FUNCTION OR DESIGN. FAIRCHILD DOES NOT ASSUME ANY LIABILITY ARISING OUT OF THE APPLICATION OR USE OF ANY PRODUCT OR CIRCUIT DESCRIBED HEREIN; NEITHER DOES IT CONVEY ANY LICENSE UNDER ITS PATENT RIGHTS, NOR THE RIGHTS OF OTHERS.

LIFE SUPPORT POLICY

FAIRCHILD'S PRODUCTS ARE NOT AUTHORIZED FOR USE AS CRITICAL COMPONENTS IN LIFE SUPPORT DEVICES OR SYSTEMS WITHOUT THE EXPRESS WRITTEN APPROVAL OF THE PRESIDENT OF FAIRCHILD SEMICONDUCTOR CORPORATION. As used herein:

1. Life support devices or systems are devices or systems which, (a) are intended for surgical implant into the body, or (b) support or sustain life, and (c) whose failure to perform when properly used in accordance with instructions for use provided in the labeling, can be reasonably expected to result in a significant injury of the user.
2. A critical component in any component of a life support device or system whose failure to perform can be reasonably expected to cause the failure of the life support device or system, or to affect its safety or effectiveness.



LittleDiode supplies new, hard to find or obsolete electronic components and semiconductors all over the world.

With over two million different components listed you are sure to find the part you need.

Feel free to visit us today at our online store:

LittleDiode.com

Looking forward to providing you with the best possible service.