

## Low Charge Injection 8-Channel High Voltage Analog Switch

### Ordering Information

$V_{PP} - V_{NN}$	Package Options				
	28-pin plastic DIP	28-lead plastic chip carrier	48-lead TQFP	$\mu$ -BGA	Die
200V	HV20220P	HV20220PJ	HV20220FG	HV20220GA	HV20220X
200V	—	HV20320PJ	—	—	—

### Features

- HVCMOS® technology for high performance
- Very low quiescent power dissipation – 10 $\mu$ A
- Output On-resistance typically 22 ohms
- Low parasitic capacitances
- DC to 10MHz analog signal frequency
- 60dB typical output off isolation at 5MHz
- CMOS logic circuitry for low power
- Excellent noise immunity
- On-chip shift register, latch and clear logic circuitry
- Flexible high voltage supplies
- Surface mount package available

### General Description

This device is a low charge injection 8-channel high-voltage analog switch integrated circuit (IC) intended for use in applications requiring high voltage switching controlled by low voltage control signals, such as ultrasound imaging and printers. Input data is shifted into an 8-bit shift register which can then be retained in an 8-bit latch. To reduce any possible clock feed-through noise, Latch Enable Bar (LE) should be left high until all bits are clocked in. Using HVCMOS technology, this switch combines high voltage bilateral DMOS switches and low power CMOS logic to provide efficient control of high voltage analog signals. The HV203 has the same electrical specifications as the HV202, but it is packaged in the 28 lead plastic chip carrier with the pin configuration of the Supertex HV2216PJ.

This IC is suitable for various combinations of high voltage supplies, e.g.,  $V_{PP}/V_{NN}$  : +50V/-150V, or +100V/-100V.

### Absolute Maximum Ratings\*

$V_{DD}$ Logic power supply voltage	-0.5V to +15V
$V_{PP} - V_{NN}$ Supply voltage	220V
$V_{PP}$ Positive high voltage supply	-0.5V to $V_{NN} + 200V$
$V_{NN}$ Negative high voltage supply	+0.5V to -200V
Logic input voltages	-0.5V to $V_{DD} + 0.3V$
Analog Signal Range	$V_{NN}$ to $V_{PP}$
Peak analog signal current/channel	3.0A
Storage temperature	-65°C to +150°C
Power dissipation	28-pin PLCC and DIP 1.2W 48 lead TQFP 1.0W

\* Absolute Maximum Ratings are those values beyond which damage to the device may occur. Functional operation under these conditions is not implied. Continuous operation of the device at the absolute rating level may affect device reliability.

11/12/01

Supertex Inc. does not recommend the use of its products in life support applications and will not knowingly sell its products for use in such applications unless it receives an adequate "products liability indemnification insurance agreement." Supertex does not assume responsibility for use of devices described and limits its liability to the replacement of devices determined to be defective due to workmanship. No responsibility is assumed for possible omissions or inaccuracies. Circuitry and specifications are subject to change without notice. For the latest product specifications, refer to the Supertex website: <http://www.supertex.com>. For complete liability information on all Supertex products, refer to the most current databook or to the Legal/Disclaimer page on the Supertex website.

# Electrical Characteristics

**DC Characteristics** (over recommended operating conditions unless otherwise noted)

Characteristics	Sym	0°C		+25°C			+70°C		Units	Test Conditions	
		min	max	min	typ	max	min	max			
Small Signal Switch (ON) Resistance	R <sub>ONS</sub>		30		26	38		48	ohms	I <sub>SIG</sub> = 5mA	V <sub>PP</sub> = 40V, V <sub>NN</sub> = -160V
			25		22	27		32		I <sub>SIG</sub> = 200mA	V <sub>NN</sub> = -100V
			25		22	27		30		I <sub>SIG</sub> = 5mA	V <sub>PP</sub> = 100V, V <sub>NN</sub> = -100V
			18		18	24		27		I <sub>SIG</sub> = 200mA	V <sub>NN</sub> = -160V, V <sub>NN</sub> = -40V
			23		20	25		30		I <sub>SIG</sub> = 5mA	V <sub>NN</sub> = -100V
			22		16	25		27		I <sub>SIG</sub> = 200mA	V <sub>NN</sub> = -40V
Small Signal Switch (ON) Resistance Matching	ΔR <sub>ONS</sub>		20		5.0	20		20	%	I <sub>SW</sub> = 5mA, V <sub>PP</sub> = 100V, V <sub>NN</sub> = -100V	
Large Signal Switch (ON) Resistance	R <sub>ONL</sub>				15				ohms	V <sub>SIG</sub> = V <sub>PP</sub> - 10V, I <sub>SIG</sub> = 1A	
Switch Off Leakage Per Switch	I <sub>SOL</sub>		5.0		1.0	10		15	μA	V <sub>SIG</sub> = V <sub>PP</sub> - 10V and V <sub>NN</sub> +10V	
DC Offset Switch Off			300		100	300		300	mV	R <sub>L</sub> = 100KΩ	
DC Offset Switch On			500		100	500		500	mV	R <sub>L</sub> = 100KΩ	
Pos. HV Supply Current	I <sub>PPQ</sub>				10	50			μA	ALL SWs OFF	
Neg. HV Supply Current	I <sub>NNQ</sub>				-10	-50			μA	ALL SWs OFF	
Pos. HV Supply Current	I <sub>PPQ</sub>				10	50			μA	ALL SWs ON I <sub>SW</sub> = 5mA	
Neg. HV Supply Current	I <sub>NNQ</sub>				-10	-50			μA	ALL SWs ON I <sub>SW</sub> = 5mA	
Switch Output Peak Current			3.0		3.0	2.0		2.0	A	V <sub>SIG</sub> duty cycle ≤ 0.1%	
Output Switch Frequency	f <sub>SW</sub>					50			KHz	Duty Cycle = 50%	
I <sub>PP</sub> Supply Current	I <sub>PP</sub>		6.5			7.0		8.0	mA	V <sub>PP</sub> = 40V, V <sub>NN</sub> = -160V	50KHz Output Switching Frequency with no load
			4.0			5.0		5.5		V <sub>PP</sub> = 100V, V <sub>NN</sub> = -100V	
			4.0			5.0		5.5		V <sub>PP</sub> = 160V, V <sub>NN</sub> = -40V	
I <sub>NN</sub> Supply Current	I <sub>NN</sub>		6.5			7.0		8.0	mA	V <sub>PP</sub> = 40V, V <sub>NN</sub> = -160V	
			4.0			5.0		5.5		V <sub>PP</sub> = 100V, V <sub>NN</sub> = -100V	
			4.0			5.0		5.5		V <sub>PP</sub> = 160V, V <sub>NN</sub> = -40V	
Logic Supply Average Current	I <sub>DD</sub>		4.0			4.0		4.0	mA	f <sub>CLK</sub> = 5MHz, V <sub>DD</sub> = 5.0V	
Logic Supply Quiescent Current	I <sub>DDQ</sub>		10			10		10	μA		
Data Out Source Current	I <sub>SOR</sub>	0.45		0.45	0.70			0.40	mA	V <sub>OUT</sub> = V <sub>DD</sub> - 0.7V	
Data Out Sink Current	I <sub>SINK</sub>	0.45		0.45	0.70			0.40	mA	V <sub>OUT</sub> = 0.7V	
Logic Input Capacitance	C <sub>IN</sub>		10			10		10	pF		

## Electrical Characteristics

**AC Characteristics** (over operating conditions  $V_{DD} = 5V$ , unless otherwise noted)

Characteristics	Sym	0°C		+25°C			+70°C		Units	Test Conditions
		min	max	min	typ	max	min	max		
Set Up Time Before $\overline{LE}$ Rises	$t_{SD}$	150		150			150		ns	
Time Width of $\overline{LE}$	$t_{WLE}$	150		150			150		ns	
Clock Delay Time to Data Out	$t_{DO}$		150			150		150	ns	
Time Width of CL	$t_{WCL}$	150		150			150		ns	
Set Up Time Data to Clock	$t_{SU}$	15		15	8.0		20		ns	
Hold Time Data from Clock	$t_h$	35		35			35		ns	
Clock Freq	$f_{CLK}$		5.0			5.0		5.0	MHz	50% duty cycle $f_{DATA} = f_{CLK}/2$
Clock Rise and Fall Times	$t_r, t_f$		50			50		50	ns	
Turn On Time	$t_{ON}$		5.0			5.0		5.0	$\mu s$	$V_{SIG} = V_{PP} - 10V$ , $R_L = 10K\Omega$
Turn Off Time	$t_{OFF}$		5.0			5.0		5.0	$\mu s$	$V_{SIG} = V_{PP} - 10V$ , $R_L = 10K\Omega$
Maximum $V_{SIG}$ Slew Rate	dv/dt		20			20		20	V/ns	$V_{PP} = 160V$ , $V_{NN} = -40V$
			20			20		20		$V_{PP} = 100V$ , $V_{NN} = -100V$
			20			20		20		$V_{PP} = 40V$ , $V_{NN} = -160V$
Off Isolation	KO	-30		-30	-33		-30		dB	$f = 5MHz$ , 1K $\Omega$ /15pF load
		-58		-58			-58		dB	$f = 5MHz$ , 50 $\Omega$ load
Switch Crosstalk	$K_{CR}$	-60		-60	-70		-60		dB	$f = 5MHz$ , 50 $\Omega$ load
Output Switch Isolation Diode Current	$I_{ID}$		300			300		300	mA	300ns pulse width, 2.0% duty cycle
Off Capacitance SW to GND	$C_{SG(OFF)}$	5.0	17	5.0	12	17	5.0	17	pF	0V, 1MHz
On Capacitance SW to GND	$C_{SG(ON)}$	25	50	25	38	50	25	50	pF	0V, 1MHz

## Electrical Characteristics

**AC Characteristics** (over operating conditions  $V_{DD} = 5V$ , unless otherwise noted)

Characteristics	Sym	+25°C			Units	Test Conditions
		min	typ	max		
Output Voltage Spike	$+V_{SPK}$			150	mV	$V_{PP} = 40V, V_{NN} = -160V, R_L = 50\Omega$
	$-V_{SPK}$					
	$+V_{SPK}$					$V_{PP} = 100V, V_{NN} = -100V, R_L = 50\Omega$
	$-V_{SPK}$					
	$+V_{SPK}$					$V_{PP} = 160V, V_{NN} = -40V, R_L = 50\Omega$
	$-V_{SPK}$					
Charge Injection	Q		820		pC	$V_{PP} = 40V, V_{NN} = -160V, V_{SIG} = 0V$
			600			$V_{PP} = 40V, V_{NN} = -160V, V_{SIG} = 0V$
			350			$V_{PP} = 40V, V_{NN} = -160V, V_{SIG} = 0V$

## Operating Conditions\*

Symbol	Parameter	Value
$V_{DD}$	Logic power supply voltage <sup>1, 3</sup>	4.5V to 13.2V
$V_{PP}$	Positive high voltage supply <sup>1, 3</sup>	40V to $V_{NN} + 200V$
$V_{NN}$	Negative high voltage supply <sup>1, 3</sup>	-40V to -160V
$V_{IH}$	High-level input voltage	$V_{DD} - 1.5V$ to $V_{DD}$
$V_{IL}$	Low-level input voltage	0V to 1.5V
$V_{SIG}$	Analog signal voltage peak to peak	$V_{NN} + 10V$ to $V_{PP} - 10V$ <sup>2</sup>
$T_A$	Operating free air-temperature	0°C to 70°C

### Notes:

- 1 Power up/down sequence is arbitrary except GND must be powered-up first and powered-down last.
- 2  $V_{SIG}$  must be  $V_{NN} \leq V_{SIG} \leq V_{PP}$  or floating during power up/down transition.
- 3 Rise and fall times of power supplies  $V_{DD}$ ,  $V_{PP}$ , and  $V_{NN}$  should not be less than 1.0msec.

# Test Circuits

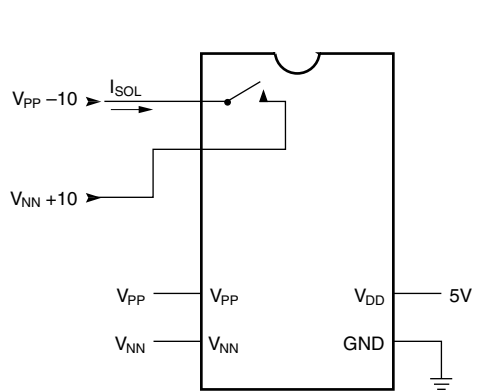

Switch OFF Leakage

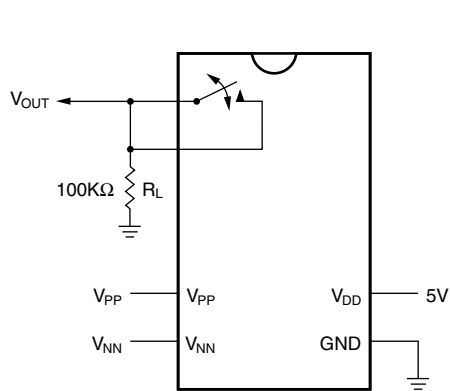

DC Offset ON/OFF

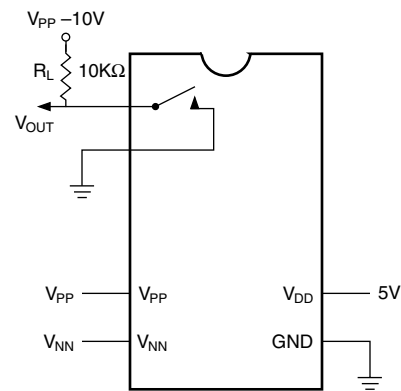

T<sub>ON</sub>/T<sub>OFF</sub> Test Circuit

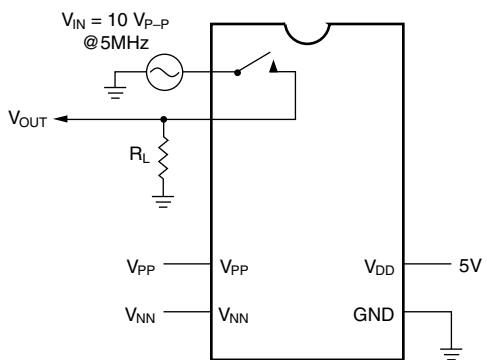

$K_O = 20 \text{Log} \frac{V_{OUT}}{V_{IN}}$   
OFF Isolation

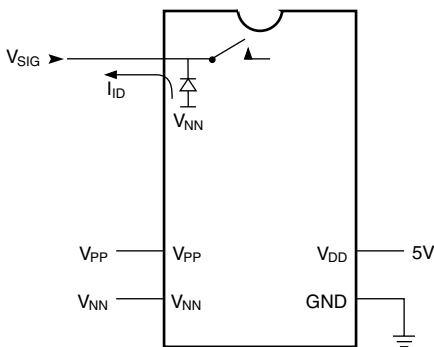

Isolation Diode Current

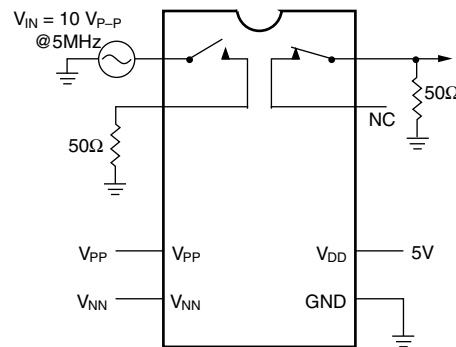

$K_{CR} = 20 \text{Log} \frac{V_{OUT}}{V_{IN}}$   
Crosstalk

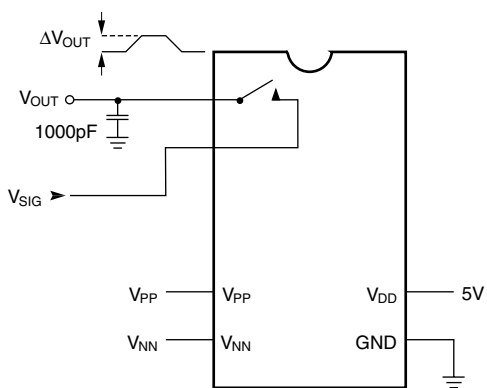

$Q = 1000\text{pF} \times \Delta V_{OUT}$   
Charge Injection

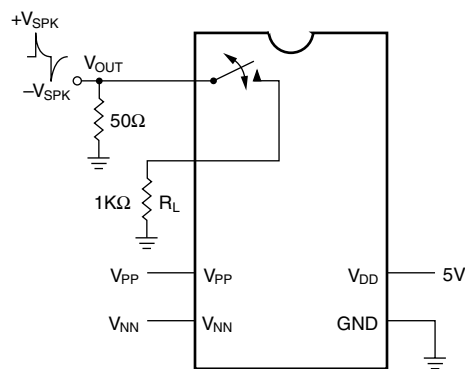

Output Voltage Spike

# Logic Timing Waveforms

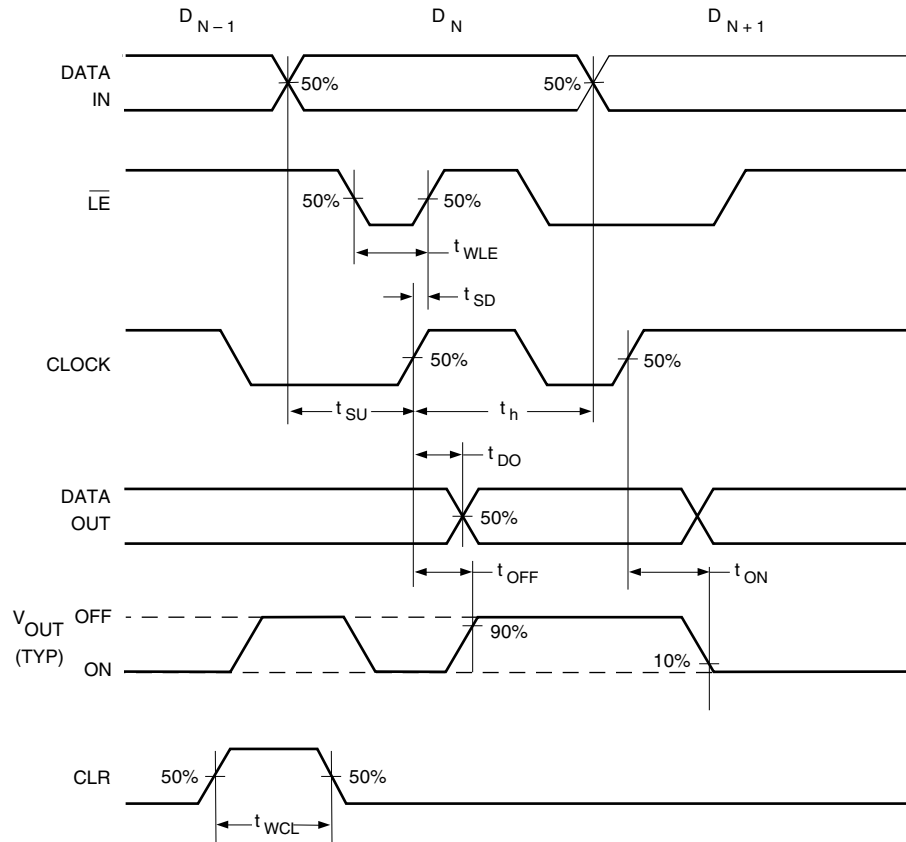

# Logic Diagram

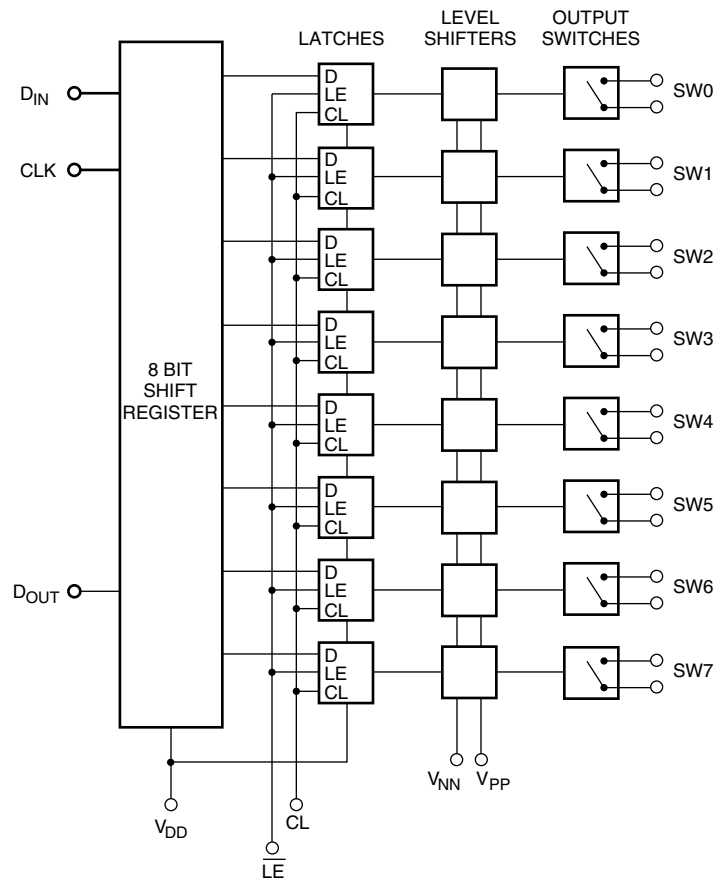

# Truth Table

D0	D1	D2	D3	D4	D5	D6	D7	$\overline{LE}$	CL	SW0	SW1	SW2	SW3	SW4	SW5	SW6	SW7				
L								L	L	OFF											
H								L	L	ON											
	L							L	L		OFF										
	H							L	L		ON										
		L						L	L			OFF									
		H						L	L			ON									
			L					L	L				OFF								
			H					L	L				ON								
				L				L	L					OFF							
				H				L	L					ON							
					L			L	L						OFF						
					H			L	L						ON						
						L		L	L							OFF					
						H		L	L							ON					
							L	L	L								OFF				
							H	L	L								ON				
X	X	X	X	X	X	X	X	H	L	HOLD PREVIOUS STATE											
X	X	X	X	X	X	X	X	X	H	OFF	OFF	OFF	OFF	OFF	OFF	OFF	OFF	OFF			

## Notes:

1. The eight switches operate independently.
2. Serial data is clocked in on the L→H transition CLK.
3. The switches go to a state retaining their present condition at the rising edge of  $\overline{LE}$ . When  $\overline{LE}$  is low the shift register data flows through the latch.
4.  $D_{OUT}$  is high when switch 7 is on.
5. Shift register clocking has no effect on the switch states if  $\overline{LE}$  is H.
6. The clear input overrides all other inputs.

# Typical Performance Curves

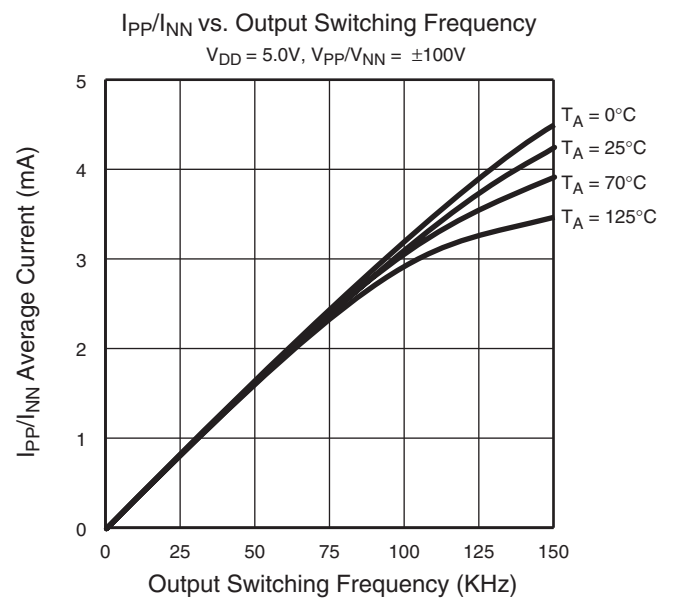
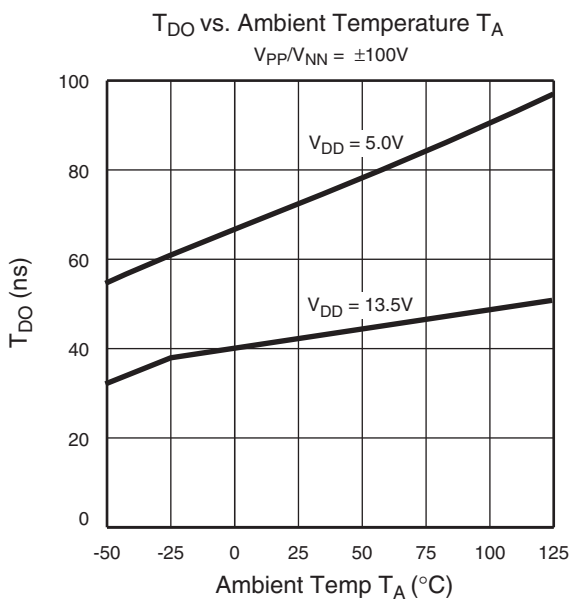
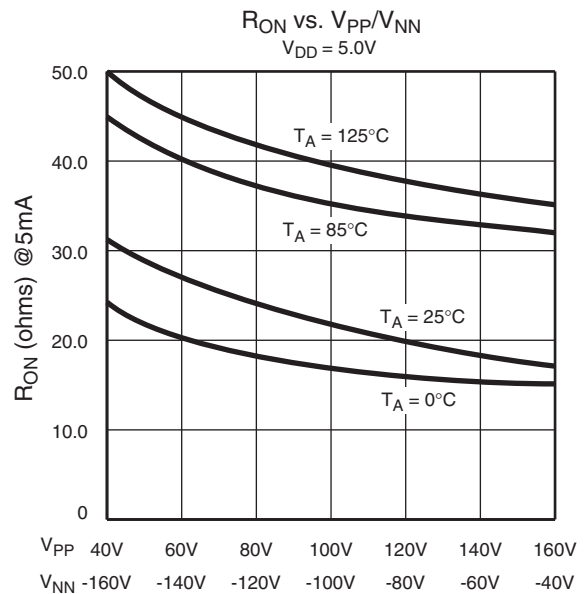
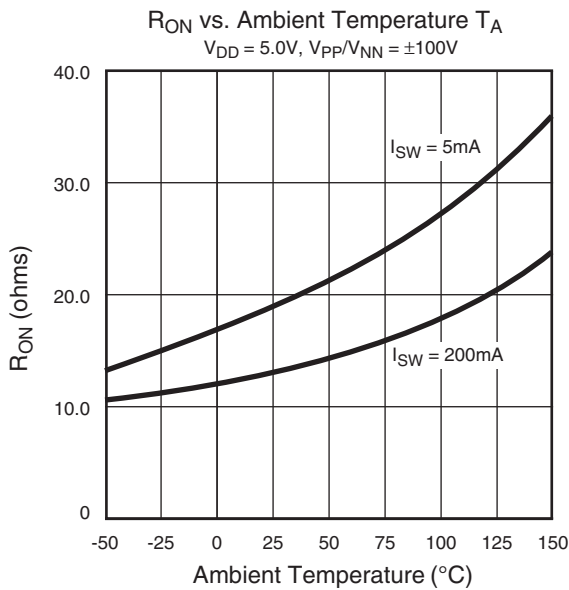
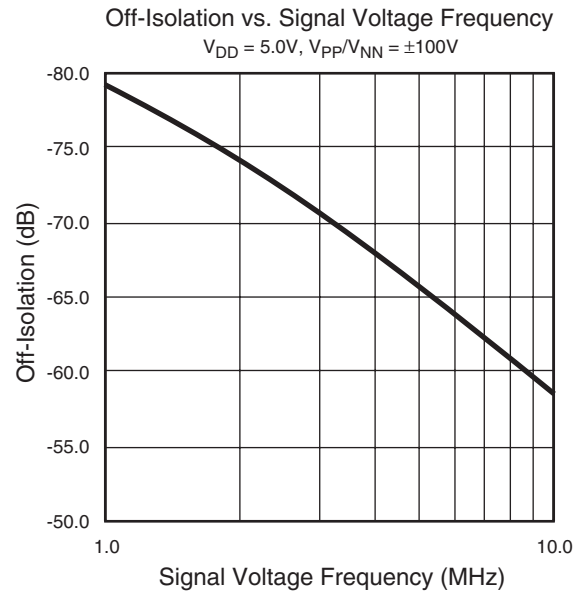
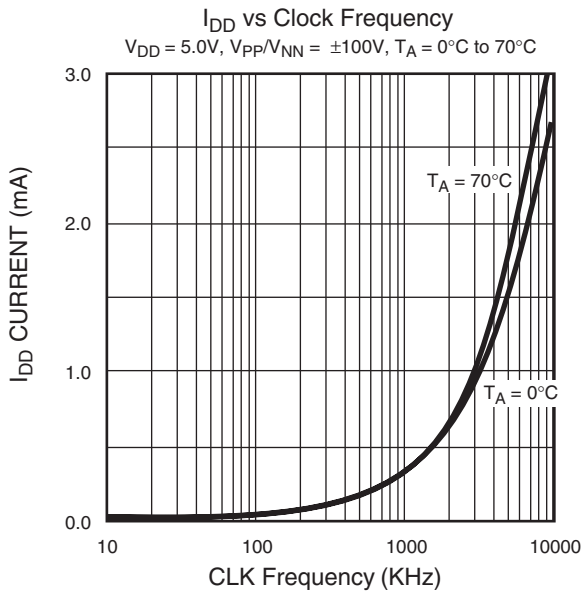

# Pin Configurations

# Package Outlines

## HV202 28-Pin DIP

Pin	Function	Pin	Function
1	SW3	15	N/C
2	SW3	16	D <sub>IN</sub>
3	SW2	17	CLK
4	SW2	18	LE
5	SW1	19	CL
6	SW1	20	D <sub>OUT</sub>
7	SW0	21	SW7
8	SW0	22	SW7
9	N/C	23	SW6
10	V <sub>PP</sub>	24	SW6
11	N/C	25	SW5
12	V <sub>NN</sub>	26	SW5
13	GND	27	SW4
14	V <sub>DD</sub>	28	SW4

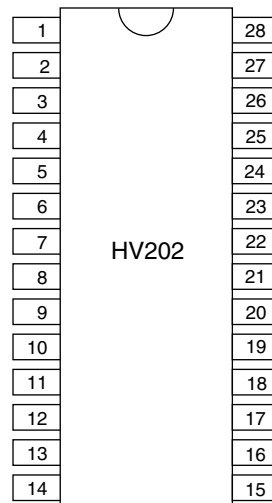

top view  
28-pin DIP

## HV202 28 Pin J-Lead

Pin	Function	Pin	Function
1	SW3	15	N/C
2	SW3	16	D <sub>IN</sub>
3	SW2	17	CLK
4	SW2	18	LE
5	SW1	19	CL
6	SW1	20	D <sub>OUT</sub>
7	SW0	21	SW7
8	SW0	22	SW7
9	N/C	23	SW6
10	V <sub>PP</sub>	24	SW6
11	N/C	25	SW5
12	V <sub>NN</sub>	26	SW5
13	GND	27	SW4
14	V <sub>DD</sub>	28	SW4

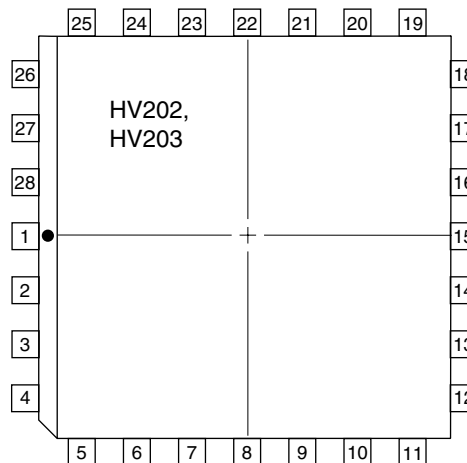

top view  
28-pin J-Lead Package

## HV203 28 Pin J-Lead

Pin	Function	Pin	Function
1	SW3	15	N/C
2	SW3	16	D <sub>IN</sub>
3	SW2	17	CLK
4	SW2	18	LE
5	SW1	19	CL
6	SW1	20	D <sub>OUT</sub>
7	SW0	21	SW7
8	SW0	22	SW7
9	V <sub>PP</sub>	23	SW6
10	V <sub>NN</sub>	24	SW6
11	N/C	25	SW5
12	GND	26	SW5
13	V <sub>DD</sub>	27	SW4
14	N/C	28	SW4

## Pin Configurations

### HV202 48-Pin TQFP

Pin	Function	Pin	Function
1	SW5	25	$V_{NN}$
2	N/C	26	N/C
3	SW4	27	N/C
4	N/C	28	GND
5	SW4	29	$V_{DD}$
6	N/C	30	N/C
7	N/C	31	N/C
8	SW3	32	N/C
9	N/C	33	$D_{IN}$
10	SW3	34	CLK
11	N/C	35	$\overline{LE}$
12	SW2	36	CLR
13	N/C	37	$D_{OUT}$
14	SW2	38	N/C
15	N/C	39	SW7
16	SW1	40	N/C
17	N/C	41	SW7
18	SW1	42	N/C
19	N/C	43	SW6
20	SW0	44	N/C
21	N/C	45	SW6
22	SW0	46	N/C
23	N/C	47	SW5
24	$V_{PP}$	48	N/C

## Package Outlines

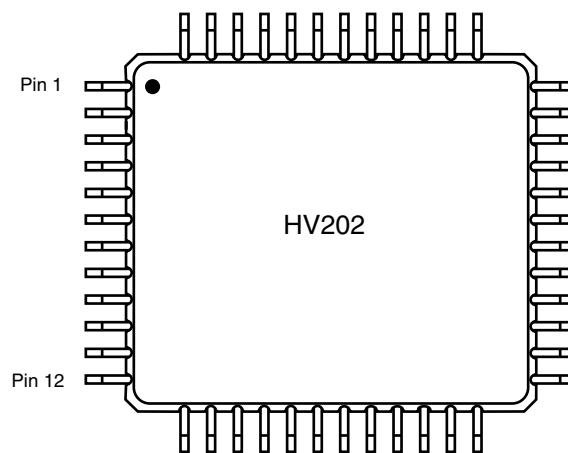

top view  
48-pin TQFP

# HV20220GA Package Outline ( $\mu$ -BGA)

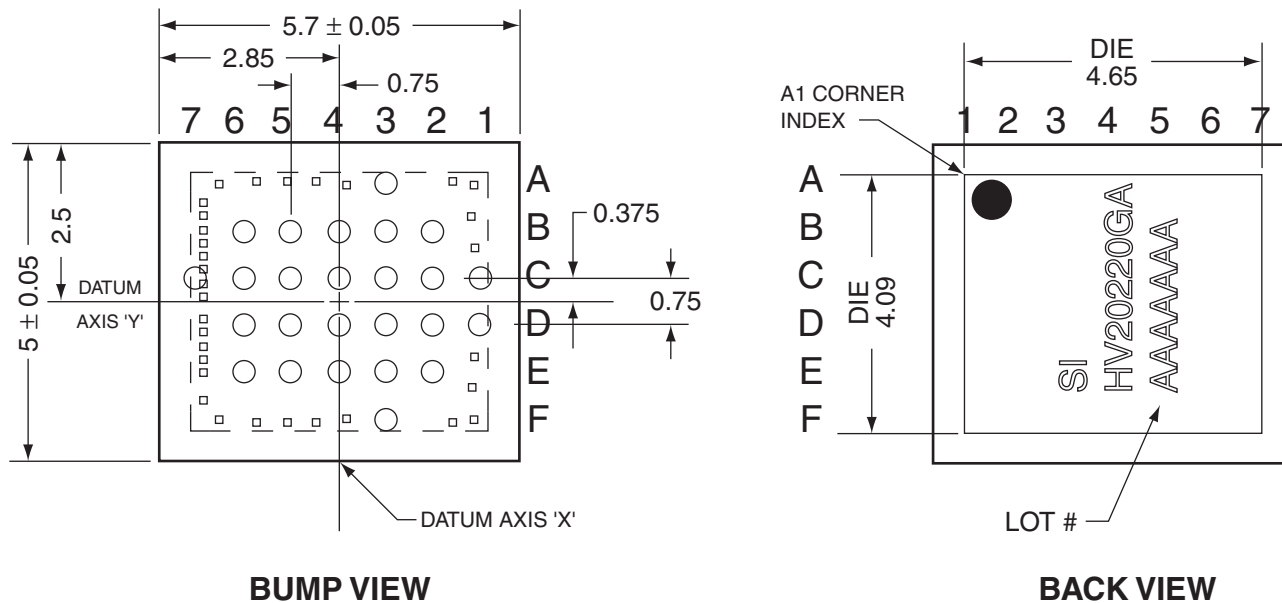

**NOTES:**

1. Dimensioning and tolerance per ASME Y14.5M-1994.
2. Do not subject part to ultrasonic cleaning or intense UV.
3. Contact ball position per JESD 95-1, SPP-010.
4. Units are in millimeters.

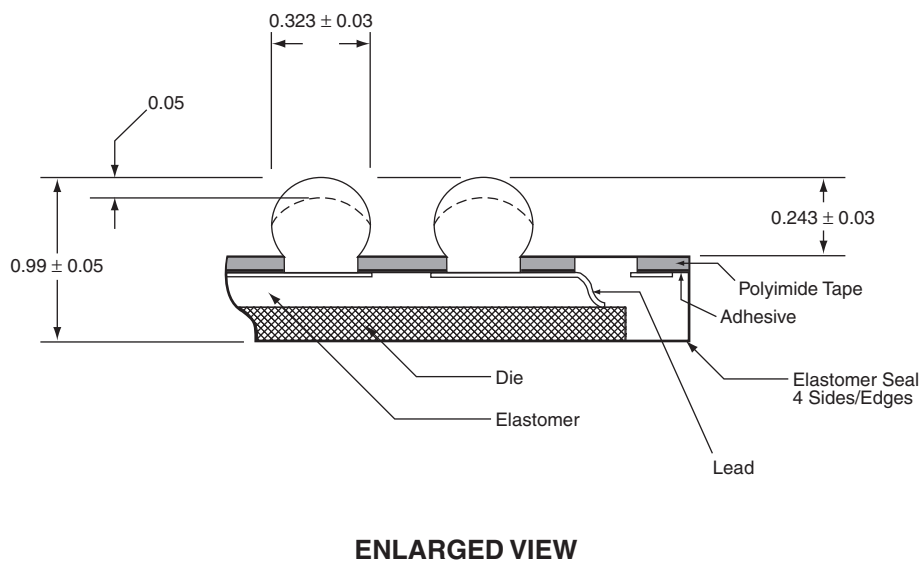

**μ-BGA Function Table**

Ball Location	Function
A3	SW1
B2	SW2
B3	SW1
B4	SW0
B5	SW0
B6	$V_{NN}$
C1	SW3
C2	SW3
C3	SW2
C4	$V_{PP}$
C5	GND
C6	$D_{IN}$
C7	$V_{DD}$
D1	SW4
D2	SW4
D3	SW5
D4	SW7
D5	$\overline{LE}$
D6	CLK
E2	SW5
E3	SW6
E4	SW7
E5	$D_{OUT}$
E6	CLR
F3	SW6



LittleDiode supplies new, hard to find or obsolete electronic components and semiconductors all over the world.

With over two million different components listed you are sure to find the part you need.

Feel free to visit us today at our online store:

[LittleDiode.com](http://LittleDiode.com)

Looking forward to providing you with the best possible service.