

Low Charge Injection 8-Channel High Voltage Analog Switch with Bleed Resistors

Ordering Information

$V_{PP} - V_{NN}$	Package Options			
	28-lead plastic chip carrier	48-lead TQFP	μ -BGA	Die
200V	HV232PJ	HV232FG	HV232GA	HV232X

Features

- HVCMOS[®] technology for high performance
- Very low quiescent power dissipation – 10 μ A
- Output On-resistance typically 22 ohms
- Integrated bleed resistors on the outputs
- Low parasitic capacitances
- DC to 10MHz analog signal frequency
- 60dB typical output off isolation at 5MHz
- CMOS logic circuitry for low power
- Excellent noise immunity
- On-chip shift register, latch and clear logic circuitry
- Flexible high voltage supplies
- Surface mount package available

General Description

The Supertex HV232 is a low charge injection 8-channel high-voltage analog switch integrated circuit (IC) with bleed resistors. The device can be used in applications requiring high voltage switching controlled by low voltage control signals, such as ultrasound imaging and printers. The bleed resistors eliminate voltage built up on capacitive loads such as piezoelectric transducers. Input data is shifted into an 8-bit shift register which can then be retained in an 8-bit latch. To reduce any possible clock feed-through noise, Latch Enable Bar (LE) should be left high until all bits are clocked in. Using HVCMOS technology, this switch combines high voltage bilateral DMOS switches and low power CMOS logic to provide efficient control of high voltage analog signals.

This IC is suitable for various combinations of high voltage supplies, e.g., V_{PP}/V_{NN} : +50V/-150V, or +100V/-100V.

Absolute Maximum Ratings*

V_{DD} Logic power supply voltage	-0.5V to +15V	
$V_{PP} - V_{NN}$ Supply voltage	220V	
V_{PP} Positive high voltage supply	-0.5V to $V_{NN} + 200V$	
V_{NN} Negative high voltage supply	+0.5V to -200V	
Logic input voltages	-0.5V to $V_{DD} + 0.3V$	
Analog Signal Range	V_{NN} to V_{PP}	
Peak analog signal current/channel	3.0A	
Storage temperature	-65°C to +150°C	
Power dissipation	μ -BGA	1.0W
	28-pin PLCC	1.2W
	48 lead TQFP	1.0W

* Absolute Maximum Ratings are those values beyond which damage to the device may occur. Functional operation under these conditions is not implied. Continuous operation of the device at the absolute rating level may affect device reliability.

Electrical Characteristics

DC Characteristics (over recommended operating conditions unless otherwise noted)

Characteristics	Sym	0°C		+25°C			+70°C		Units	Test Conditions	
		min	max	min	typ	max	min	max			
Small Signal Switch (ON) Resistance	R _{ONS}		30		26	38		48	ohms	I _{SIG} = 5mA	V _{PP} = 40V,
			25		22	27		32		I _{SIG} = 200mA	V _{NN} = -160V
			25		22	27		30		I _{SIG} = 5mA	V _{PP} = 100V,
			18		18	24		27		I _{SIG} = 200mA	V _{NN} = -100V
			23		20	25		30		I _{SIG} = 5mA	V _{PP} = 160V,
			22		16	25		27		I _{SIG} = 200mA	V _{NN} = -40V
Small Signal Switch (ON) Resistance Matching	ΔR _{ONS}		20		5.0	20		20	%	I _{SW} = 5mA, V _{PP} = 100V, V _{NN} = -100V	
Large Signal Switch (ON) Resistance	R _{ONL}				15				ohms	V _{SIG} = V _{PP} - 10V, I _{SIG} = 1A	
Output Switch Shunt Resistance	R _{INT}			20	35	50			KΩ	Output switch to R _{GND}	
Switch Off Leakage Per Switch	I _{SOL}		5.0		1.0	10		15	μA	V _{SIG} = V _{PP} - 10V	
DC Offset Switch Off			300		100	300		300	mV	No Load	
DC Offset Switch On			500		100	500		500	mV	No Load	
Pos. HV Supply Current	I _{PPQ}				10	50			μA	ALL SWs OFF	
Neg. HV Supply Current	I _{NNQ}				-10	-50			μA	ALL SWs OFF	
Pos. HV Supply Current	I _{PPQ}				10	50			μA	ALL SWs ON, I _{SW} = 5mA	
Neg. HV Supply Current	I _{NNQ}				-10	-50			μA	ALL SWs ON, I _{SW} = 5mA	
Switch Output Peak Current			3.0		3.0	2.0		2.0	A	V _{SIG} duty cycle ≤ 0.1%	
Output Switch Frequency	f _{SW}					50			KHz	Duty Cycle = 50%	
I _{PP} Supply Current	I _{PP}		6.5			7.0		8.0	mA	V _{PP} = 40V, V _{NN} = -160V	50KHz Output Switching Frequency with no load
			4.0			5.0		5.5		V _{PP} = 100V, V _{NN} = -100V	
			4.0			5.0		5.5		V _{PP} = 160V, V _{NN} = -40V	
I _{NN} Supply Current	I _{NN}		6.5			7.0		8.0	mA	V _{PP} = 40V, V _{NN} = -160V	
			4.0			5.0		5.5		V _{PP} = 100V, V _{NN} = -100V	
			4.0			5.0		5.5		V _{PP} = 160V, V _{NN} = -40V	
Logic Supply Average Current	I _{DD}		4.0			4.0		4.0	mA	f _{CLK} = 5MHz, V _{DD} = 5.0V	
Logic Supply Quiescent Current	I _{DDQ}		10			10		10	μA		
Data Out Source Current	I _{SOR}	0.45		0.45	0.70		0.40		mA	V _{OUT} = V _{DD} - 0.7V	
Data Out Sink Current	I _{SINK}	0.45		0.45	0.70		0.40		mA	V _{OUT} = 0.7V	
Logic Input Capacitance	C _{IN}		10			10		10	pF		

Electrical Characteristics

AC Characteristics (over operating conditions $V_{DD} = 5V$, unless otherwise noted)

Characteristics	Sym	0°C		+25°C			+70°C		Units	Test Conditions
		min	max	min	typ	max	min	max		
Set Up Time Before \overline{LE} Rises	t_{SD}	150		150			150		ns	
Time Width of \overline{LE}	t_{WLE}	150		150			150		ns	
Clock Delay Time to Data Out	t_{DO}	55	150	60		150	70	150	ns	
Time Width of CL	t_{WCL}	150		150			150		ns	
Set Up Time Data to Clock	t_{SU}	15		15	8.0		20		ns	
Hold Time Data from Clock	t_h	35		35			35		ns	
Clock Freq	f_{CLK}		5.0			5.0		5.0	MHz	50% duty cycle $f_{DATA} = f_{CLK}/2$
Clock Rise and Fall Times	t_r, t_f		1.0			1.0		1.0	μs	
Turn On Time	t_{ON}		5.0			5.0		5.0	μs	$V_{SIG} = V_{PP} - 10V$, $R_L = 10K\Omega$
Turn Off Time	t_{OFF}		5.0			5.0		5.0	μs	$V_{SIG} = V_{PP} - 10V$, $R_L = 10K\Omega$
Maximum V_{SIG} Slew Rate	dv/dt		20			20		20	V/ns	$V_{PP} = 160V$, $V_{NN} = -40V$
			20			20		20		$V_{PP} = 100V$, $V_{NN} = -100V$
			20			20		20		$V_{PP} = 40V$, $V_{NN} = -160V$
Off Isolation	KO	-30		-30	-33		-30		dB	f = 5MHz, 1K Ω //15pF load
		-58		-58			-58			f = 5MHz, 50 Ω load
Switch Crosstalk	K_{CR}	-60		-60	-70		-60		dB	f = 5MHz, 50 Ω load
Output Switch Isolation Diode Current	I_{ID}		300			300		300		mA
Off Capacitance SW to GND	$C_{SG(OFF)}$	5.0	17	5.0	12	17	5.0	17	pF	0V, 1MHz
On Capacitance SW to GND	$C_{SG(ON)}$	25	50	25	38	50	25	50	pF	0V, 1MHz

Electrical Characteristics

AC Characteristics (over operating conditions $V_{DD} = 5V$, unless otherwise noted)

Characteristics	Sym	+25°C			Units	Test Conditions
		min	typ	max		
Output Voltage Spike	$+V_{SPK}$			150	mV	$V_{PP} = 40V, V_{NN} = -160V, R_L = 50\Omega$
	$-V_{SPK}$			150		
	$+V_{SPK}$			150		$V_{PP} = 100V, V_{NN} = -100V, R_L = 50\Omega$
	$-V_{SPK}$			150		
	$+V_{SPK}$			150		$V_{PP} = 160V, V_{NN} = -40V, R_L = 50\Omega$
	$-V_{SPK}$			150		

Operating Conditions*

Symbol	Parameter	Value
V_{DD}	Logic power supply voltage ^{1, 3}	4.5V to 13.2V
V_{PP}	Positive high voltage supply ^{1, 3}	40V to $V_{NN} + 200V$
V_{NN}	Negative high voltage supply ^{1, 3}	-40V to -160V
V_{IH}	High-level input voltage	$V_{DD} - 1.5V$ to V_{DD}
V_{IL}	Low-level input voltage	0V to 1.5V
V_{SIG}	Analog signal voltage peak to peak	$V_{NN} + 10V$ to $V_{PP} - 10V$ ²
T_A	Operating free air-temperature	0°C to 70°C

Notes:

- 1 Power up/down sequence is arbitrary except GND must be powered-up first and powered-down last.
- 2 V_{SIG} must be $V_{NN} \leq V_{SIG} \leq V_{PP}$ or floating during power up/down transition.
- 3 Rise and fall times of power supplies V_{DD} , V_{PP} , and V_{NN} should not be less than 1.0msec.

Test Circuits

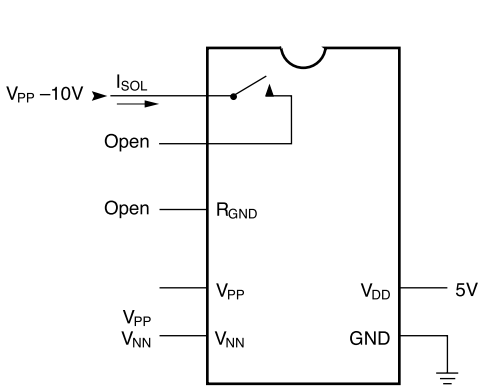

Switch OFF Leakage

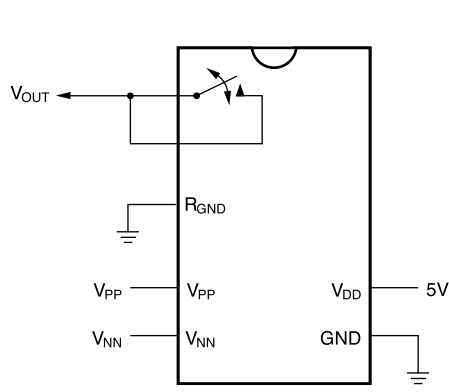

DC Offset ON/OFF

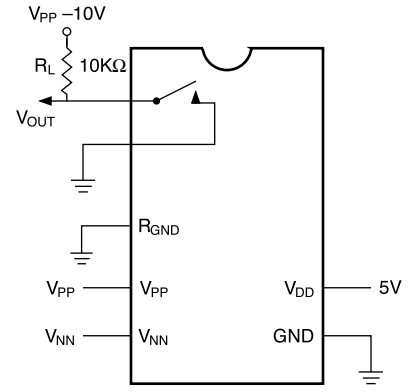

T_{ON}/T_{OFF} Test Circuit

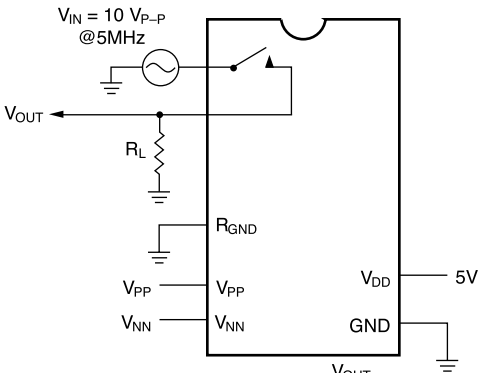

$K_O = 20 \text{Log} \frac{V_{OUT}}{V_{IN}}$
OFF Isolation

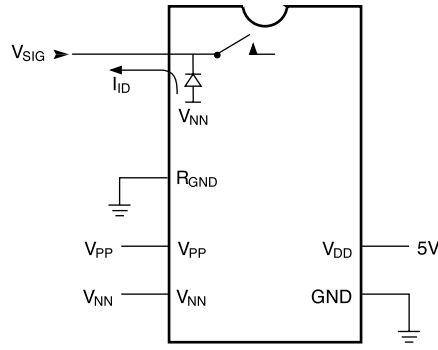

Isolation Diode Current

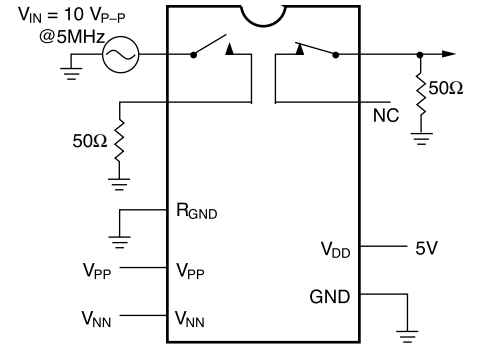

$K_{CR} = 20 \text{Log} \frac{V_{OUT}}{V_{IN}}$
Crosstalk

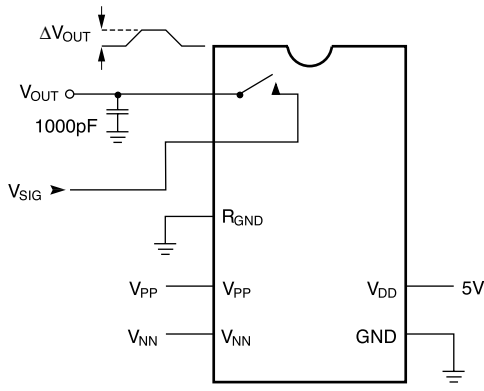

$Q = 1000 \text{pF} \times \Delta V_{OUT}$
Charge Injection

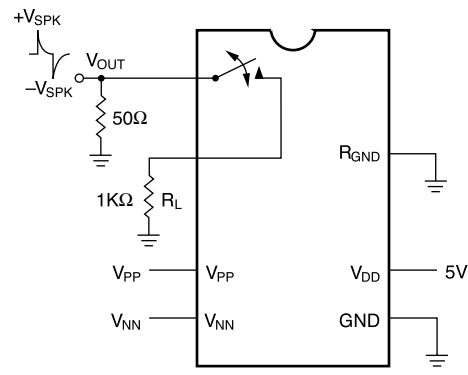

Output Voltage Spike

Logic Timing Waveforms

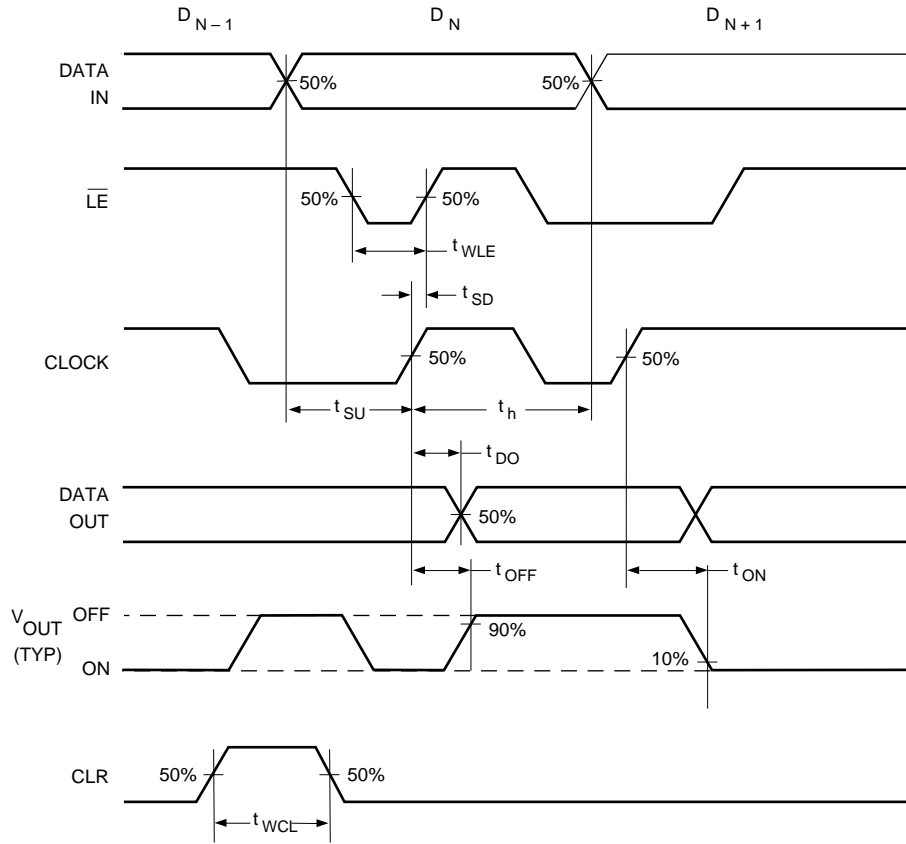

Block Diagram

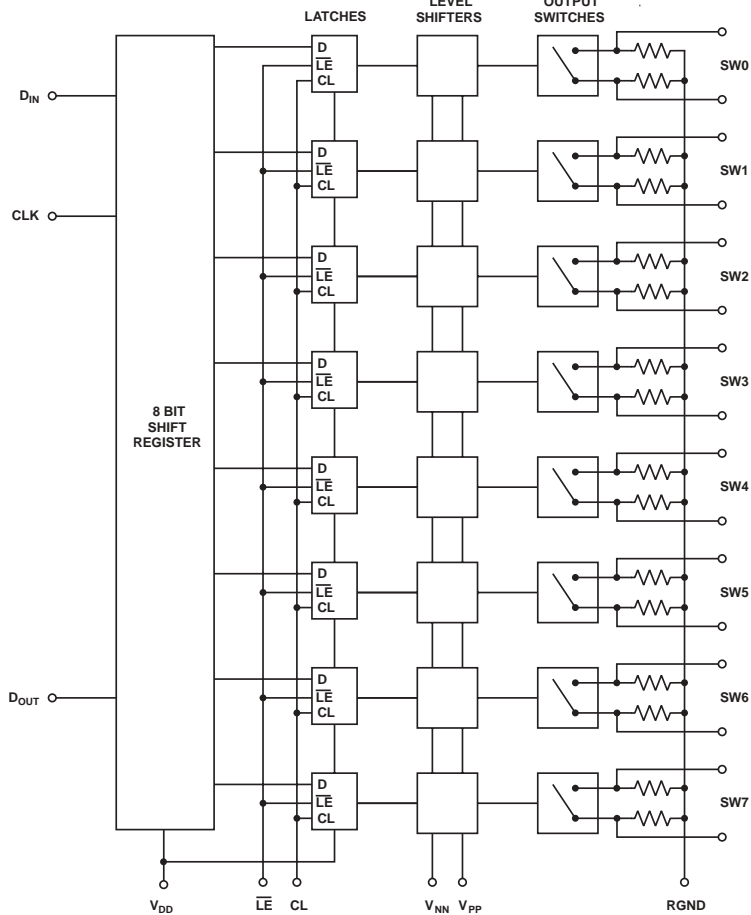

Truth Table

D0	D1	D2	D3	D4	D5	D6	D7	\overline{LE}	CL	SW0	SW1	SW2	SW3	SW4	SW5	SW6	SW7		
L								L	L	OFF									
H								L	L	ON									
	L							L	L		OFF								
	H							L	L		ON								
		L						L	L			OFF							
		H						L	L			ON							
			L					L	L				OFF						
			H					L	L				ON						
				L				L	L					OFF					
				H				L	L					ON					
					L			L	L						OFF				
					H			L	L						ON				
						L		L	L							OFF			
						H		L	L							ON			
							L	L	L								OFF		
							H	L	L								ON		
X	X	X	X	X	X	X	X	H	L	HOLD PREVIOUS STATE									
X	X	X	X	X	X	X	X	X	H	OFF	OFF	OFF	OFF	OFF	OFF	OFF	OFF	OFF	

Notes:

1. The eight switches operate independently.
2. Serial data is clocked in on the L→ H transition CLK.
3. The switches go to a state retaining their present condition at the rising edge of \overline{LE} . When \overline{LE} is low the shift register data flows through the latch.
4. D_{OUT} is high when switch 7 is on.
5. Shift register clocking has no effect on the switch states if \overline{LE} is H.
6. The clear input overrides all other inputs.

Pin Configurations

Package Outlines

HV232 28 Pin J-Lead

Pin	Function	Pin	Function
1	SW3	15	N/C
2	SW3	16	D _{IN}
3	SW2	17	CLK
4	SW2	18	LE
5	SW1	19	CL
6	SW1	20	D _{OUT}
7	SW0	21	SW7
8	SW0	22	SW7
9	N/C	23	SW6
10	V _{PP}	24	SW6
11	R _{GND}	25	SW5
12	V _{NN}	26	SW5
13	GND	27	SW4
14	V _{DD}	28	SW4

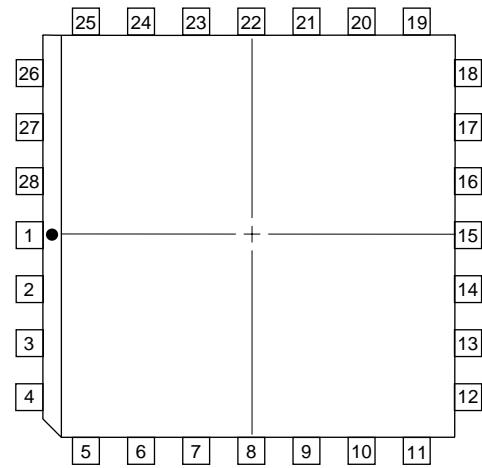

top view
28-pin J-Lead Package

HV232 48-Pin TQFP

Pin	Function	Pin	Function
1	SW5	25	V _{NN}
2	N/C	26	N/C
3	SW4	27	R _{GND}
4	N/C	28	GND
5	SW4	29	V _{DD}
6	N/C	30	N/C
7	N/C	31	N/C
8	SW3	32	N/C
9	N/C	33	D _{IN}
10	SW3	34	CLK
11	N/C	35	LE
12	SW2	36	CLR
13	N/C	37	D _{OUT}
14	SW2	38	N/C
15	N/C	39	SW7
16	SW1	40	N/C
17	N/C	41	SW7
18	SW1	42	N/C
19	N/C	43	SW6
20	SW0	44	N/C
21	N/C	45	SW6
22	SW0	46	N/C
23	N/C	47	SW5
24	V _{PP}	48	N/C

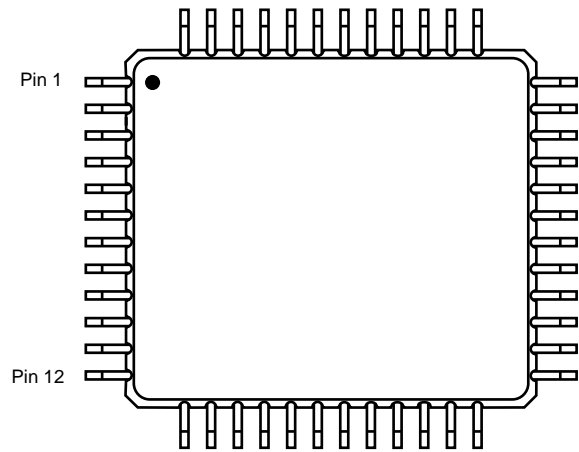

top view
48-pin TQFP

HV232GA Package Outline (μ -BGA)

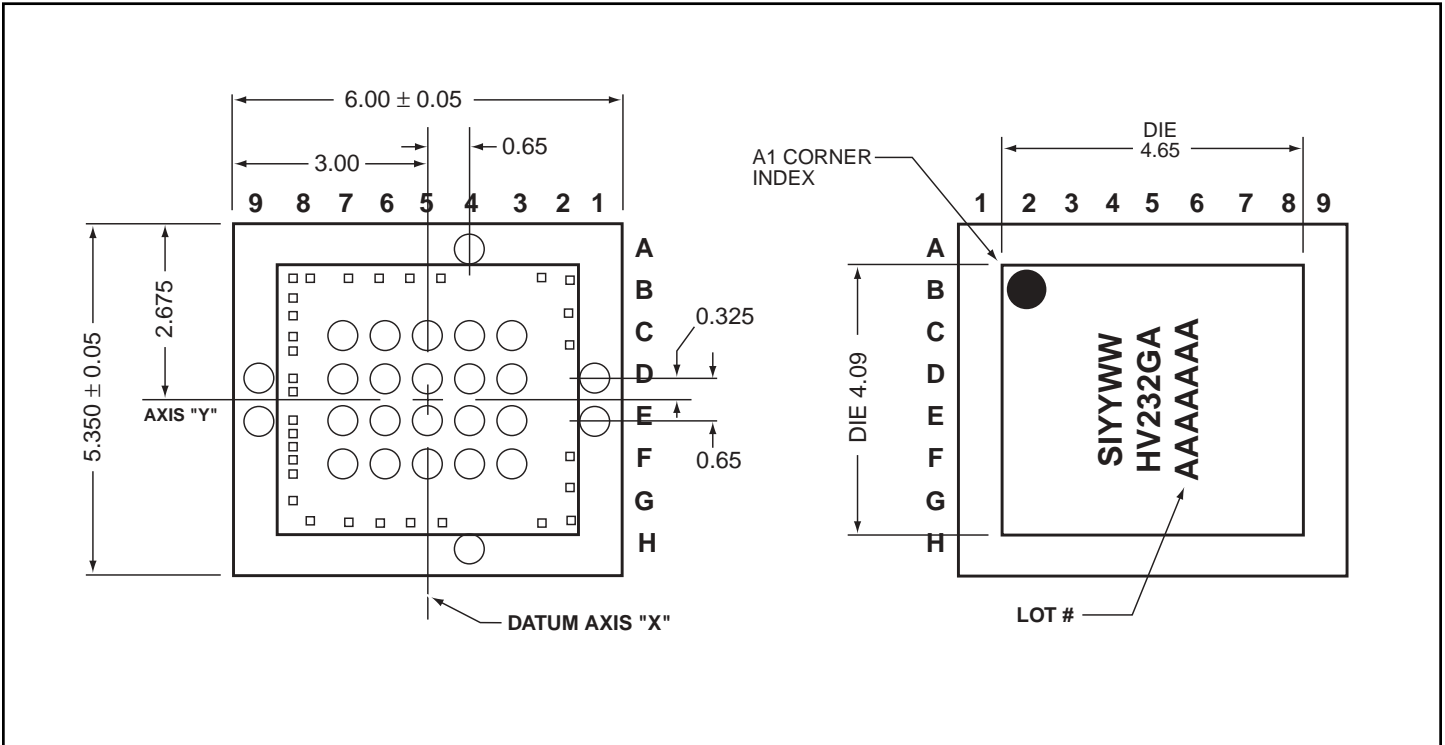

Notes:

1. Dimensioning and tolerance per ASME Y14.5M-1994.
2. Do not subject part to ultrasonic cleaning or intense UV.
3. Contact ball position per JESD 95-1, SPP-010.
4. Units are in millimeters.

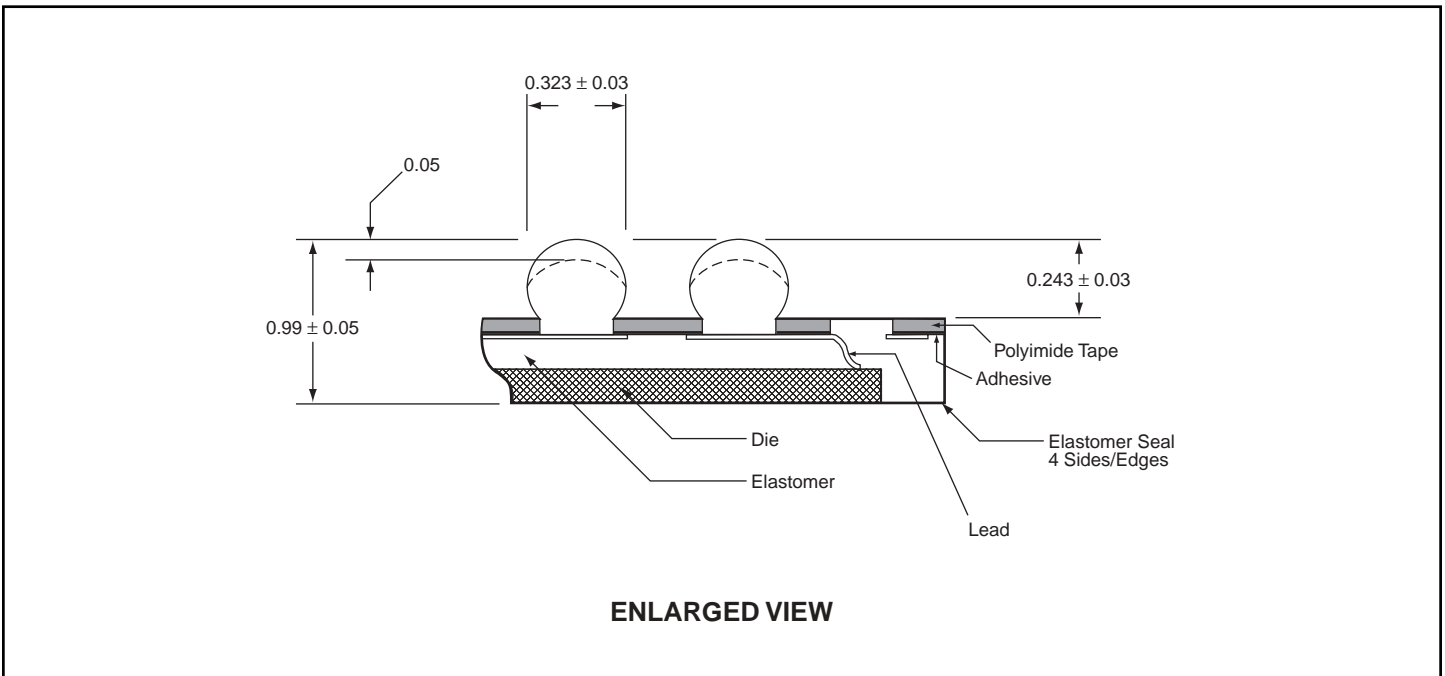

μ-BGA Function Table

Ball Location	Function
A4	SW1
C3	SW2
C4	SW1
C5	SW0
C6	V _{PP}
C7	V _{NN}
D1	SW3
D3	SW3
D4	SW2
D5	SW0
D6	R _{GND}
D7	GND
D9	V _{DD}
E1	SW4
E3	SW4
E4	SW5
E5	SW7
E6	$\overline{\text{LE}}$
E7	CLK
E9	D _{IN}
F3	SW5
F4	SW6
F5	SW7
F6	D _{OUT}
F7	CLR
H4	SW6



LittleDiode supplies new, hard to find or obsolete electronic components and semiconductors all over the world.

With over two million different components listed you are sure to find the part you need.

Feel free to visit us today at our online store:

LittleDiode.com

Looking forward to providing you with the best possible service.