

## High Voltage Current Mode PWM Controller for ISDN Equipment

### Ordering Information

$+V_{IN}$		Feedback Accuracy	Max Duty Cycle	Package Options		
Min	Max			14 Pin Plastic DIP	14 Pin Narrow Body SOIC	Die
15V	250V	$< \pm 1\%$	49%	HV9605P	HV9605NG	HV9605X

### Features

- BiCMOS/DMOS technology
- Current mode control
- 49% duty cycle operation
- Programmable START/STOP capability
- 15V to 250V input range internal start-up regulator
- 6.0 $\mu$ A standby supply current for  $+V_{IN} < 20V$
- 0.9mA operating supply current
- 5.0V  $V_{DD}$  supply operation
- 30KHz to 300KHz internal oscillator
- 15KHz to 150KHz converter output frequency
- 1.0MHz low offset error amplifier
- 1.20V 2% band gap reference
- Output driver optimized for under 10W applications
- Low driver output impedance with  $V_{DD} = 0V$
- Fast (90nsec) over current shutdown
- All pins are ESD protected

### Applications

- ISDN network terminations
- ISDN terminals
- ISDN terminal adapters
- Feature phones
- SLIC circuits
- PBX systems
- Modems
- Distributed power systems
- DC/DC converters

### General Description

The Supertex HV9605 is a BiCMOS/DMOS single-output, current mode, pulse width modulator IC designed to meet the requirements of ETR-060 for ISDN applications. In a 14 pin package, it provides all the necessary functions to implement a single-switch PWM with a minimum of external parts.

Utilizing Supertex's proprietary BiCMOS/DMOS technology, it requires less than one tenth of the operating power of conventional bipolar PWM ICs. Dynamic range for regulation is also increased to approximately 8 times that of similar bipolar parts. It operates directly from any DC input voltage between 15 and 250 VDC. The START and STOP input voltage thresholds can be programmed within the operating input voltage range by means of a resistor divider, provided  $+V_{IN(START)} > +V_{IN(STOP)}$ . The output stage is push-pull CMOS, eliminating the need for external clamping diodes. The clock frequency is set with a single external resistor.

### Absolute Maximum Ratings\*

$+V_{IN}$ , Input Voltage	-0.5V to +250V
Supply Voltage, $V_{DD}$	-0.5V to +10V
Operating Temperature Range	-40°C to +85°C
Storage Temperature Range	-65°C to +150°C
Power Dissipation @ 25°C, SOIC	750mW
Power Dissipation @ 25°C, Plastic DIP	1000mW

\*All voltages referenced to GND

## Electrical Characteristics

Symbol	Parameters	Min	Typ	Max	Unit	Conditions
--------	------------	-----	-----	-----	------	------------

### Pre-Regulator/Start-Up

$+V_{IN}$	Regulator input voltage	15		250	V	
$+I_{IN}$	Input leakage current			6.0	$\mu$ A	$+V_{IN}=20V$ , Start=0V, Stop=0V
$+I_{IN}$	Input leakage current			50	$\mu$ A	$+V_{IN} = 250V$ , $V_{DD} = 4.7V$
$+I_{START}$	Pre-regulator start-up current	5.0			mA	$+V_{IN} = 15V$ , Start & Stop 10M $\Omega$ to + $V_{IN}$
$V_{DD}$	Regulator output voltage	4.4	4.5	4.6	V	
UVLO	Under voltage lockout threshold	4.1	4.2	4.4	V	$V_{DD}$ rising
HYST	Under voltage hysteresis	0.1	0.3	0.4	V	

### Supply

$V_{DD}$	Operating range	4.7		8.0	V	
$I_{DD}$	Supply current		0.9	1.3	mA	OUT open, $f_{OUT} = 20KHz$ to 150KHz, $V_{DD} = 5V$

### Start/Stop Control

$V_{START}$	Start threshold	6.72	7.30	7.88	V	
$I_{START}$	Start input current			0.05	$\mu$ A	$+V_{IN} = 18V$
$I_{STOP}$	Stop input current			0.05	$\mu$ A	$+V_{IN} = 18V$
$V_{CLAMP}$	Zener clamp voltage on STOP Pin	20			V	

### MOSFET Driver Output

$V_{OUT(HIGH)}$	Output high voltage	4.85	4.90		V	$I_{OUT} = 10mA$ , $V_{DD} = 5.00V$
$V_{OUT(LOW)}$	Output low voltage		0.05	0.15	V	$I_{OUT} = -10mA$
$t_R$	Rise time		30	50	nsec	$C_L = 250pf$
$t_F$	Fall time		20	50	nsec	$C_L = 250pf$

### Oscillator

$f_{OUT}$	Output converter frequency		150		KHz	$R_T = 91K\Omega$
		45	50	55	KHz	$R_T = 390K\Omega$
		31.5	35	38.5	KHz	$R_T = 560K\Omega$
		18	20	22	KHz	$R_T = 1.0M\Omega$
$T_C$	Temperature coefficient		100	300	PPM/ $^{\circ}C$	$f_{OUT} = 50KHz$
$\Delta f/f$	Voltage stability		1	3	%	$f_{OUT} = 50KHz$ , $4.5V < V_{DD} < 5.5V$

## Electrical Characteristics (continued)

Symbol	Parameters	Min	Typ	Max	Unit	Conditions
--------	------------	-----	-----	-----	------	------------

### PWM

$D_{MAX}$	Maximum duty cycle	49.0		49.9	%	$f_{OUT} = 20\text{KHz}$
$D_{MIN}$	Minimum duty cycle			0	%	
	Minimum pulse width before pulse drop out		80	125	nsec	

### Reference

$V_{REF}$	Reference output voltage	1.176	1.200	1.224	V	$T_A = 25^\circ\text{C}$
$V_{REF}$	Load regulation		1.0	5.0	mV	$0 < I_{REF} < 0.3\text{mA}$
$V_{REF}$	Line regulation		2.0	5.0	mV	$3.0\text{V} < V_{DD} < 5.5\text{V}$
$V_{REF}$	Reference output voltage	1.159	1.200	1.241	V	$-40^\circ\text{C} < T_A < 85^\circ\text{C}$
	Long term stability		3.0		mV	$T_A = 125^\circ\text{C}, 1000\text{hrs}$
$I_{REF(SHORT)}$	Short circuit current		0.5	1.0	mA	$V_{REF} = \text{SGND}$

### Current Sensing

$V_{CS}$	Usable control current sense range			$V_{CS}(\text{limit})$	V	
$V_{CS(LIMIT)}$	Current limit threshold	0.6	0.7	0.8	V	
$t_{DELAY}$	Current limit delay to output		90	120	nsec	$V_{CS} = 1.5\text{V}$

### Error Amplifier

$V_{FB}$	Feedback voltage	1.188	1.200	1.212	V	REF shorted to NI, FB shorted to Comp, $T_A = 25^\circ\text{C}$
$I_{FB}$ or $I_{NI}$	Input bias current		25	200	nA	$V_{FB} = 3.0\text{V}, V_{NI} = 2.5\text{V}$
$V_{OS}$	Input offset voltage		5.0	25	mV	
$V_{CM}$	Common mode input range	0		$V_{DD}-1$	V	
$A_{VOL}$	Open loop voltage gain	65	90		dB	
BW	Unity gain bandwidth	1.0	1.5		MHz	
$I_{SOURCE}$	Output current sourcing		-2	-1	mA	$V_{FB} < V_{NI}$
$I_{SINK}$	Output current sinking	2	4		mA	$V_{FB} > V_{NI}$
PSRR	Power supply rejection	50	72		dB	$4.5\text{V} < V_{DD} < 5.5\text{V}, f=1\text{KHz}$

### Status Output

$I_{SINK}$	Output current sinking	5.0	10		mA	$V_{STATUS} = 2.0\text{V}$
$I_{SOURCE}$	Output current sourcing	5.0	10	15	$\mu\text{A}$	
$V_{STATUS(HIGH)}$	High output voltage	$V_{DD}-0.2$		$V_{DD}$	V	No load
$V_{STATUS(LOW)}$	Low output voltage		1.0	2.0	V	Sinking 5mA
			0.02	0.04	V	Sinking 100 $\mu\text{A}$
$t_R$	Rise time	1.0	5.0		msec	4.7nF From Status to GND

## Pin Description

**SGND** - Common connection for all low level signal and digital circuits. While SGND and PGND must be electrically connected together, having separate common pins enhances the ability of the designer to prevent coupling of noise into critical circuits.

**PGND** - This pin provides common return for the high transient current of the output driver circuits. While PGND and SGND must be electrically connected, having a separate connection prevents common noise created by the high transient currents of the output driver from being injected into critical circuits.

**+V<sub>IN</sub>** - This is the start-up linear pre-regulator input which can accept DC input voltages in the range of 15V to 250V. With START and STOP set to more than 20V, the leakage current on this pin is less than 6.0 $\mu$ A at +V<sub>IN</sub> = 20V.

**START** - The resistive divider from +V<sub>IN</sub> sets the start voltage.

**STOP** - The resistive divider from +V<sub>IN</sub> sets the stop voltage.

**V<sub>DD</sub>** - This is the supply pin for the PWM circuits. When the input voltage to the +V<sub>IN</sub> pin exceeds the start voltage the input regulator seeks to regulate the voltage on the capacitor connected to this pin to a nominal 4.5V.

**OUT** - This high current push-pull CMOS output is intended to drive the gate of a power MOSFET. In order to protect the power MOSFET in high electrical noise environment, this output appears as low impedance to PGND when V<sub>DD</sub> is at zero volts.

**CS** - This is the current sense input to the PWM comparators. Under normal operation the over current limit is triggered when the voltage on this pin is at 0.70V and the loop control operating peak current may be set to any level below this, typically in the range of 0.2 to 0.5V.

**COMP** - The low impedance output of the error amplifier.

**FB** - The high impedance inverting input of the error amplifier.

**NI** - The high impedance non-inverting input of the error amplifier.

**REF** - This pin provides a 2% accuracy 1.20V low output impedance buffered reference which is current limited to 0.5mA and should be bypassed, REF to SGND, with a 0.1 $\mu$ F ceramic capacitor.

**RT** - The resistor connected from this pin to SGND sets the frequency of the internal oscillator by setting the charging current for the internal timing capacitor. The oscillator frequency is twice the PWM output frequency.

**STATUS** - This output is held low until the +V<sub>IN</sub> voltage reaches the programmed START voltage. It remains low until the bootstrap supply to V<sub>DD</sub> forces the voltage above the internal regulator set point. It is further held low while the control amplifier output on the COMP pin is forced to its high limit by a low output from the converter. Once all these conditions are satisfied, this output will rise to V<sub>DD</sub> with a time constant set by the external capacitor indicating that normal operation has been reached. This output may be used to control the reset of a microprocessor.

## Pin Configuration

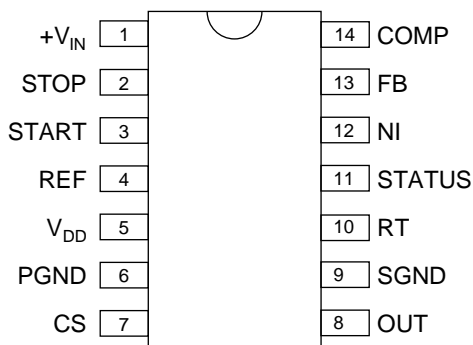

14 Pin SOIC/DIP Package

# Functional Block Diagram

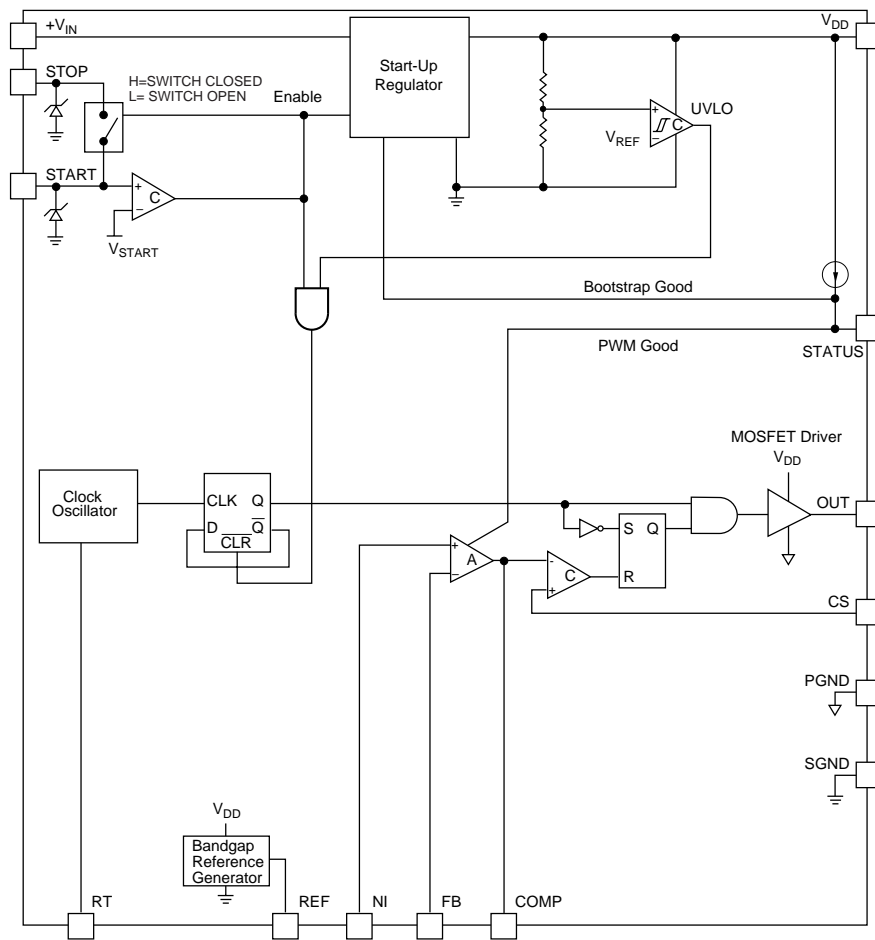

# Typical Application Circuit

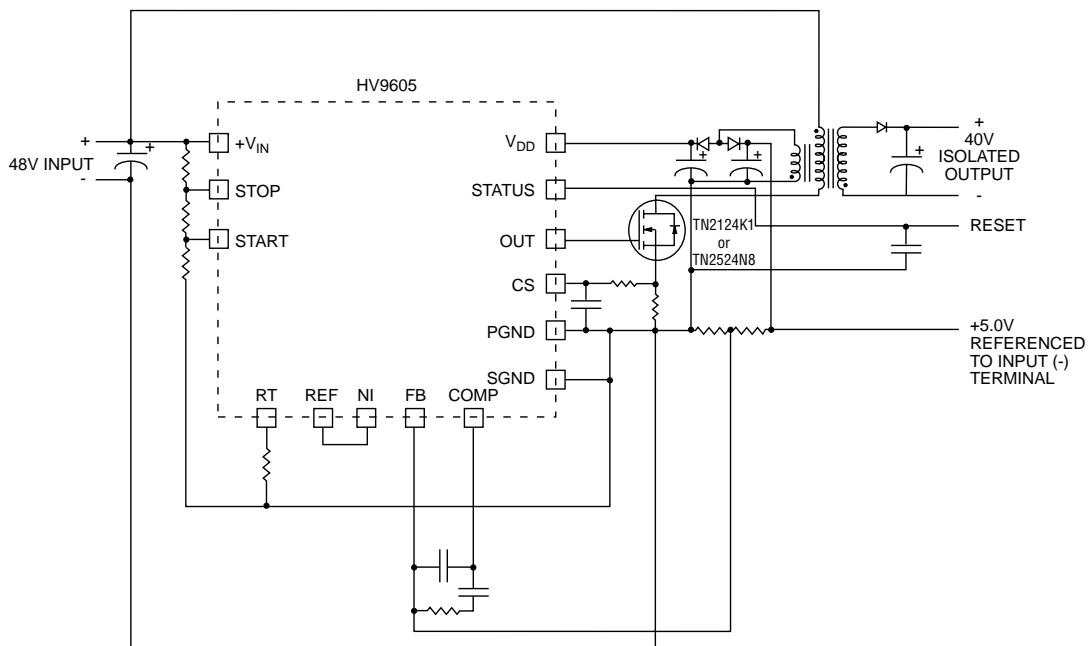



LittleDiode supplies new, hard to find or obsolete electronic components and semiconductors all over the world.

With over two million different components listed you are sure to find the part you need.

Feel free to visit us today at our online store:

[LittleDiode.com](http://LittleDiode.com)

Looking forward to providing you with the best possible service.