

## 2M × 8-Bit Dynamic RAM 2k Refresh (Hyper Page Mode-EDO)

**HYB 5117805/BSJ-50/-60**  
**HYB 3117805/BSJ-50/-60**

### Advanced Information

- 2 097 152 words by 8-bit organization
- 0 to 70 °C operating temperature
- Hyper Page Mode-EDO-operation
- Performance:

		-50	-60	
$t_{RAC}$	RAS access time	50	60	ns
$t_{CAC}$	CAS access time	13	15	ns
$t_{AA}$	Access time from address	25	30	ns
$t_{RC}$	Read/Write cycle time	84	104	ns
$t_{HPC}$	Hyper page mode (EDO) cycle time	20	25	ns

- Power dissipation:

	HYB 5117805		HYB 3117805		
	-50	-60	-50	-60	
Power Supply	5 ± 10%		3.3 ± 0.3 V		
Active	440	385	288	252	mW
TTL Standby	11		7.2		mW
CMOS Standby	5.5		3.6		mW

- Read, write, read-modify-write,  $\overline{CAS}$ -before- $\overline{RAS}$  refresh,  $\overline{RAS}$ -only refresh, hidden refresh and test mode
- All inputs, outputs and clocks fully TTL (5 V versions) and LV-TTL (3.3 V version)-compatible
- 2048 refresh cycles / 32 ms (2k-refresh)
- Plastic Package: P-SOJ-28-3 400 mil

The HYB 5(3)117805 are 16 MBit dynamic RAMs based on the die revisions "G" & "F" and organized as 2 097 152 words by 8-bits. The HYB 5(3)117805 utilizes a submicron CMOS silicon gate process technology, as well as advanced circuit techniques to provide wide operating margins, both internally and for the system user. Multiplexed address inputs permit the HYB 5(3)117805BJ to be packaged in a standard SOJ-28 plastic packages. Package with 400 mil width are available. These packages provide high system bit densities and are compatible with commonly used automatic testing and insertion equipment.

### Ordering Information

Type	Ordering Code	Package	Descriptions
HYB 5117805BSJ-50	Q67100-Q1104	P-SOJ-28-3 400 mil	5 V 50 ns EDO-DRAM
HYB 5117805BSJ-60	Q67100-Q1105	P-SOJ-28-3 400 mil	5 V 60 ns EDO-DRAM
HYB 3117805BSJ-50	on request	P-SOJ-28-3 400 mil	3.3 V 50 ns EDO-DRAM
HYB 3117805BSJ-60	on request	P-SOJ-28-3 400 mil	3.3 V 60 ns EDO-DRAM

### Pin Names and Configuration

A0 - A10	Row Address Inputs
A0 - A9	Column Address Inputs
$\overline{\text{RAS}}$	Row Address Strobe
$\overline{\text{OE}}$	Output Enable
I/O1 - I/O8	Data Input/Output
$\overline{\text{CAS}}$	Column Address Strobe
$\overline{\text{WE}}$	Read/Write Input
$V_{\text{CC}}$	Power Supply + 5 V for HYB 5117800 + 3.3 V for HYB 3117805
$V_{\text{SS}}$	Ground (0 V)
N.C.	Not Connected

### P-SOJ-28 400 mil

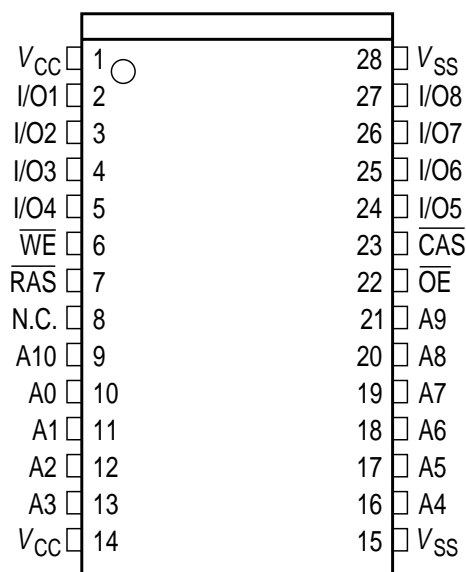

SPP02803

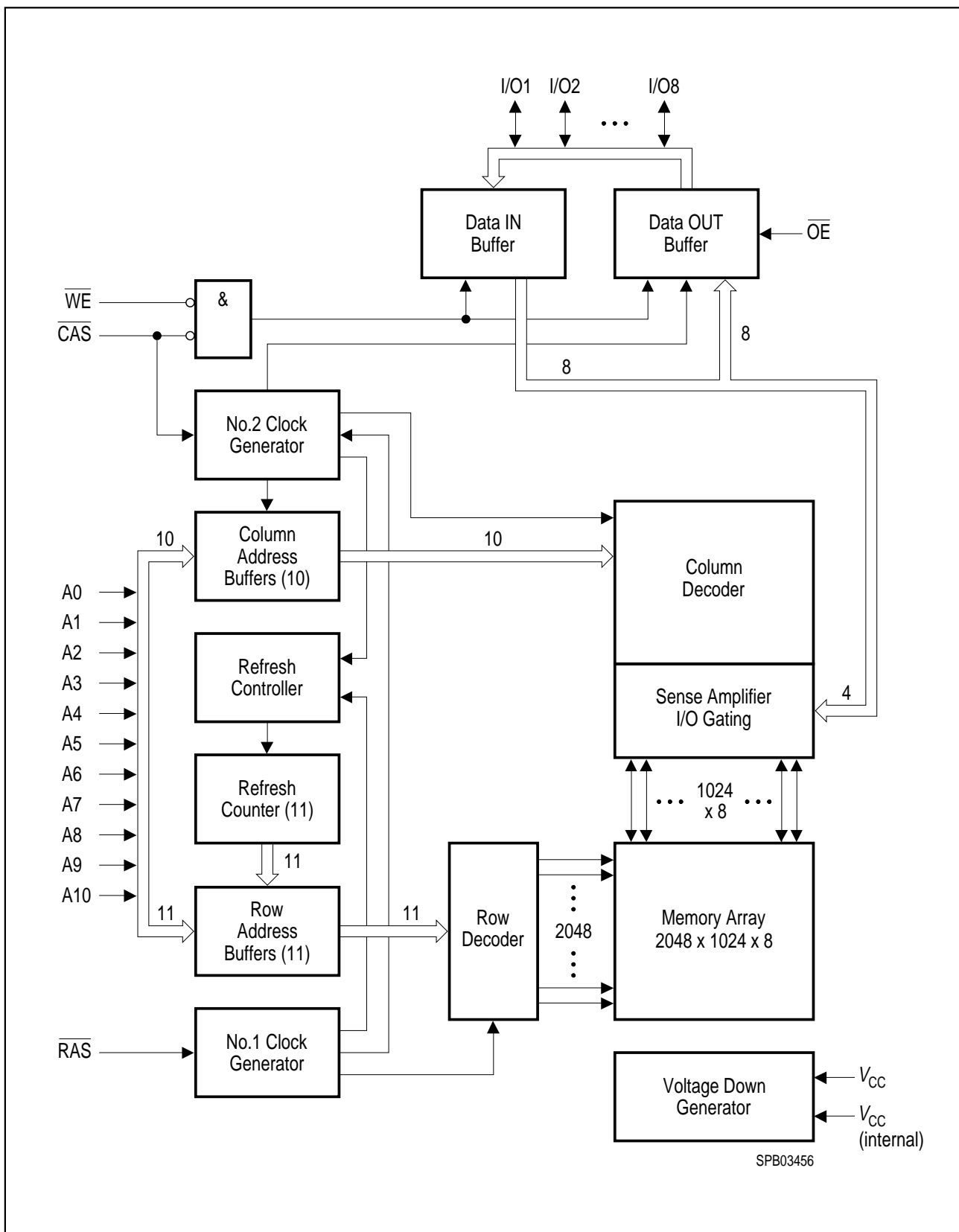

Block Diagram

**Absolute Maximum Ratings**

Operating temperature range ..... 0 to 70 °C  
 Storage temperature range..... – 55 to 150 °C  
 Input/output voltage (5 V versions) ..... – 0.5 to min ( $V_{CC} + 0.5, 7.0$ ) V  
 Input/output voltage (3.3 V versions) ..... – 0.5 to min ( $V_{CC} + 0.5, 4.6$ ) V  
 Power supply voltage (5 V versions) ..... – 1.0 V to 7.0 V  
 Power supply voltage (3.3 V versions) ..... – 1.0 V to 4.6 V  
 Power dissipation (5 V versions) ..... 1.0 W  
 Power dissipation (3.3 V versions) ..... 0.5 W  
 Data out current (short circuit) ..... 50 mA

*Note: Stresses above those listed under “Absolute Maximum Ratings” may cause permanent damage of the device. Exposure to absolute maximum rating conditions for extended periods may affect device reliability.*

**DC Characteristics**

$T_A = 0$  to 70 °C,  $V_{SS} = 0$  V,  $t_T = 2$  ns

Parameter	Symbol	Limit Values		Unit	Test Condition
		min.	max.		

**5 V Versions**

Power supply voltage	$V_{CC}$	4.5	5.5	V	
Input high voltage	$V_{IH}$	2.4	$V_{CC} + 0.5$	V	1
Input low voltage	$V_{IL}$	– 0.5	0.8	V	1
Output high voltage ( $I_{OUT} = -5$ mA)	$V_{OH}$	2.4	–	V	1
Output low voltage ( $I_{OUT} = 4.2$ mA)	$V_{OL}$	–	0.4	V	1

**3.3 V Versions**

Power supply voltage	$V_{CC}$	3.0	3.6	V	
Input high voltage	$V_{IH}$	2.0	$V_{CC} + 0.5$	V	1
Input low voltage	$V_{IL}$	– 0.5	0.8	V	1
TTL Output high voltage ( $I_{OUT} = -2$ mA)	$V_{OH}$	2.4	–	V	1
TTL Output low voltage ( $I_{OUT} = 2$ mA)	$V_{OL}$	–	0.4	V	1
CMOS Output high voltage ( $I_{OUT} = -100$ μA)	$V_{OH}$	$V_{CC} - 0.2$	–	V	
CMOS Output low voltage ( $I_{OUT} = 100$ μA)	$V_{OL}$	–	0.2	V	

**Common Parameters**

Input leakage current ( $0\text{ V} \leq V_{IH} \leq V_{CC} + 0.3\text{ V}$ , all other pins = 0 V)	$I_{I(L)}$	– 10	10	μA	1
Output leakage current (DO is disabled, $0\text{ V} \leq V_{OUT} \leq V_{CC} + 0.3\text{ V}$ )	$I_{O(L)}$	– 10	10	μA	1

### DC Characteristics (cont'd)

$T_A = 0$  to  $70$  °C,  $V_{SS} = 0$  V,  $t_T = 2$  ns

Parameter	Symbol	Limit Values		Unit	Test Condition
		min.	max.		
Average $V_{CC}$ supply current -50 ns version -60 ns version ( $\overline{RAS}$ , $\overline{CAS}$ , address cycling: $t_{RC} = t_{RC\ MIN.}$ )	$I_{CC1}$	–	80 70	mA mA	2, 3, 4 2, 3, 4
Standby $V_{CC}$ supply current ( $\overline{RAS} = \overline{CAS} = V_{IH}$ )	$I_{CC2}$	–	2	mA	–
Average $V_{CC}$ supply current, during $\overline{RAS}$ -only refresh cycles -50 ns version -60 ns version ( $\overline{RAS}$ cycling, $\overline{CAS} = V_{IH}$ , $t_{RC} = t_{RC\ MIN.}$ )	$I_{CC3}$	–	80 70	mA mA	2, 4 2, 4
Average $V_{CC}$ supply current, during hyper page mode (EDO) -50 ns version -60 ns version ( $\overline{RAS} = V_{IL}$ , $\overline{CAS}$ , address cycling: $t_{PC} = t_{PC\ MIN.}$ )	$I_{CC4}$	–	35 30	mA mA	2, 3, 4 2, 3, 4
Standby $V_{CC}$ supply current ( $\overline{RAS} = \overline{CAS} = V_{CC} - 0.2$ V)	$I_{CC5}$	–	1	mA	1
Average $V_{CC}$ supply current, during $\overline{CAS}$ -before-RAS refresh mode -50 ns version -60 ns version ( $\overline{RAS}$ , $\overline{CAS}$ cycling: $t_{RC} = t_{RC\ MIN.}$ )	$I_{CC6}$	–	80 70	mA mA	2, 4 2, 4

### Capacitance

$T_A = 0$  to  $70$  °C,  $V_{CC} = 5$  V  $\pm$  10 %,  $f = 1$  MHz

Parameter	Symbol	Limit Values		Unit
		min.	max.	
Input capacitance (A0 to A10)	$C_{I1}$	–	5	pF
Input capacitance ( $\overline{RAS}$ , $\overline{CAS}$ , $\overline{WE}$ , $\overline{OE}$ )	$C_{I2}$	–	7	pF
I/O capacitance (I/O1 - I/O8)	$C_{I0}$	–	7	pF

### AC Characteristics <sup>5,6</sup>

$T_A = 0$  to  $70$  °C,  $V_{CC} = 5\text{ V} \pm 10\%$  /  $V_{CC} = 3.3\text{ V} \pm 0.3\text{ V}$ ,  $t_T = 2\text{ ns}$

Parameter	Symbol	Limit Values				Unit	Note
		-50		-60			
		min.	max.	min.	max.		

### Common Parameters

Random read or write cycle time	$t_{RC}$	84	–	104	–	ns	
$\overline{\text{RAS}}$ precharge time	$t_{RP}$	30	–	40	–	ns	
$\overline{\text{RAS}}$ pulse width	$t_{RAS}$	50	10k	60	10k	ns	
$\overline{\text{CAS}}$ pulse width	$t_{CAS}$	8	10k	10	10k	ns	
Row address setup time	$t_{ASR}$	0	–	0	–	ns	
Row address hold time	$t_{RAH}$	8	–	10	–	ns	
Column address setup time	$t_{ASC}$	0	–	0	–	ns	
Column address hold time	$t_{CAH}$	8	–	10	–	ns	
$\overline{\text{RAS}}$ to $\overline{\text{CAS}}$ delay time	$t_{RCD}$	12	37	14	45	ns	
$\overline{\text{RAS}}$ to column address delay	$t_{RAD}$	10	25	12	30	ns	
$\overline{\text{RAS}}$ hold time	$t_{RSH}$	13	–	15	–	ns	
$\overline{\text{CAS}}$ hold time	$t_{CSH}$	40	–	50	–	ns	
$\overline{\text{CAS}}$ to $\overline{\text{RAS}}$ precharge time	$t_{CRP}$	5	–	5	–	ns	
Transition time (rise and fall)	$t_T$	1	50	1	50	ns	<sup>7</sup>
Refresh period	$t_{REF}$	–	32	–	32	ms	

### Read Cycle

Access time from $\overline{\text{RAS}}$	$t_{RAC}$	–	50	–	60	ns	8, 9
Access time from $\overline{\text{CAS}}$	$t_{CAC}$	–	13	–	15	ns	8, 9
Access time from column address	$t_{AA}$	–	25	–	30	ns	8, 10
$\overline{\text{OE}}$ access time	$t_{OEA}$	–	13	–	15	ns	
Column address to $\overline{\text{RAS}}$ lead time	$t_{RAL}$	25	–	30	–	ns	
Read command setup time	$t_{RCS}$	0	–	0	–	ns	
Read command hold time	$t_{RCH}$	0	–	0	–	ns	<sup>11</sup>
Read command hold time referenced to $\overline{\text{RAS}}$	$t_{RRH}$	0	–	0	–	ns	<sup>11</sup>
$\overline{\text{CAS}}$ to output in low-Z	$t_{CLZ}$	0	–	0	–	ns	<sup>8</sup>
Output buffer turn-off delay	$t_{OFF}$	0	13	0	15	ns	<sup>12</sup>
Output turn-off delay from $\overline{\text{OE}}$	$t_{OEZ}$	0	13	0	15	ns	<sup>12</sup>

**AC Characteristics (cont'd)** <sup>5, 6</sup>

$T_A = 0$  to  $70$  °C,  $V_{CC} = 5$  V  $\pm$  10 % /  $V_{CC} = 3.3$  V  $\pm$  0.3 V,  $t_T = 2$  ns

Parameter	Symbol	Limit Values				Unit	Note
		-50		-60			
		min.	max.	min.	max.		
Data to $\overline{\text{CAS}}$ low delay	$t_{DZC}$	0	–	0	–	ns	13
Data to $\overline{\text{OE}}$ low delay	$t_{DZO}$	0	–	0	–	ns	13
$\overline{\text{CAS}}$ high to data delay	$t_{CDD}$	10	–	13	–	ns	14
$\overline{\text{OE}}$ high to data delay	$t_{ODD}$	10	–	13	–	ns	14

**Write Cycle**

Write command hold time	$t_{WCH}$	8	–	10	–	ns	
Write command pulse width	$t_{WCP}$	8	–	10	–	ns	
Write command setup time	$t_{WCS}$	0	–	0	–	ns	15
Write command to $\overline{\text{RAS}}$ lead time	$t_{RWL}$	8	–	10	–	ns	
Write command to $\overline{\text{CAS}}$ lead time	$t_{CWL}$	8	–	10	–	ns	
Data setup time	$t_{DS}$	0	–	0	–	ns	16
Data hold time	$t_{DH}$	8	–	10	–	ns	16

**Read-Modify-Write Cycle**

Read-write cycle time	$t_{RWC}$	113	–	138	–	ns	
$\overline{\text{RAS}}$ to $\overline{\text{WE}}$ delay time	$t_{RWD}$	64	–	77	–	ns	15
$\overline{\text{CAS}}$ to $\overline{\text{WE}}$ delay time	$t_{CWD}$	27	–	32	–	ns	15
Column address to $\overline{\text{WE}}$ delay time	$t_{AWD}$	39	–	47	–	ns	15
$\overline{\text{OE}}$ command hold time	$t_{OEH}$	10	–	13	–	ns	

**Hyper Page Mode (EDO) Cycle**

Hyper page mode (EDO) cycle time	$t_{HPC}$	20	–	25	–	ns	
$\overline{\text{CAS}}$ precharge time	$t_{CP}$	8	–	10	–	ns	
Access time from $\overline{\text{CAS}}$ precharge	$t_{CPA}$	–	27	–	32	ns	7
Output data hold time	$t_{COH}$	5	–	5	–	ns	
$\overline{\text{RAS}}$ pulse width in EDO mode	$t_{RAS}$	50	200k	60	200k	ns	
$\overline{\text{CAS}}$ precharge to $\overline{\text{RAS}}$ delay	$t_{RHCP}$	27	–	32	–	ns	
$\overline{\text{OE}}$ setup time prior to $\overline{\text{CAS}}$	$t_{OES}$	5	–	5	–	5	

### AC Characteristics (cont'd) <sup>5, 6</sup>

$T_A = 0$  to  $70$  °C,  $V_{CC} = 5$  V  $\pm$  10 % /  $V_{CC} = 3.3$  V  $\pm$  0.3 V,  $t_T = 2$  ns

Parameter	Symbol	Limit Values				Unit	Note
		-50		-60			
		min.	max.	min.	max.		

### Hyper Page Mode (EDO) Read-Modify-Write Cycle

Hyper page mode (EDO) read-write cycle time	$t_{PRWC}$	58	–	68	–	ns	
$\overline{CAS}$ precharge to $\overline{WE}$	$t_{CPWD}$	41	–	49	–	ns	

### $\overline{CAS}$ -before- $\overline{RAS}$ Refresh Cycle

$\overline{CAS}$ setup time	$t_{CSR}$	10	–	10	–	ns	
$\overline{CAS}$ hold time	$t_{CHR}$	10	–	10	–	ns	
$\overline{RAS}$ to $\overline{CAS}$ precharge time	$t_{RPC}$	5	–	5	–	ns	
Write to $\overline{RAS}$ precharge time	$t_{WRP}$	10	–	10	–	ns	
Write hold time referenced to $\overline{RAS}$	$t_{WRH}$	10	–	10	–	ns	

### $\overline{CAS}$ -before- $\overline{RAS}$ Counter Test Cycle

$\overline{CAS}$ precharge time ( $\overline{CAS}$ -before- $\overline{RAS}$ counter test cycle)	$t_{CPT}$	35	–	40	–	ns	
--	-----------	----	---	----	---	----	--

### Test Mode

Write command setup time	$t_{WTS}$	10	–	10	–	ns	
Write command hold time	$t_{WTH}$	10	–	10	–	ns	
$\overline{CAS}$ hold time	$t_{CHRT}$	30	–	30	–	ns	
$\overline{RAS}$ hold time in test mode	$t_{RAHT}$	30	–	30	–	ns	

**Notes**

1. All voltages are referenced to  $V_{SS}$ .
2.  $I_{CC1}$ ,  $I_{CC3}$ ,  $I_{CC4}$  and  $I_{CC6}$  depend on cycle rate.
3.  $I_{CC1}$  and  $I_{CC4}$  depend on output loading. Specified values are obtained with the output open.
4. Address can be changed once or less while  $RAS = V_{IL}$ . In case of  $I_{CC4}$  it can be changed once or less during a hyper page mode (EDO) cycle
5. An initial pause of 200  $\mu s$  is required after power-up followed by 8  $\overline{RAS}$  cycles of which at least one cycle has to be a refresh cycle, before proper device operation is achieved. In case of using the internal refresh counter, a minimum of 8  $\overline{CAS}$ -before- $\overline{RAS}$  initialization cycles instead of 8  $\overline{RAS}$  cycles are required.
6. AC measurements assume  $t_T = 2$  ns.
7.  $V_{IH(MIN.)}$  and  $V_{IL(MAX.)}$  are reference levels for measuring timing of input signals. Transition times are also measured between  $V_{IH}$  and  $V_{IL}$ .
8. Measured with the specified current load and 100 pF at  $V_{OL} = 0.8$  V and  $V_{OH} = 2.0$  V. Access time is determined by the latter of  $t_{RAC}$ ,  $t_{CAC}$ ,  $t_{AA}$ ,  $t_{CPA}$ ,  $t_{OEA}$ .  $t_{CAC}$  is measured from tristate.
9. Operation within the  $t_{RCD(MAX.)}$  limit ensures that  $t_{RAC(MAX.)}$  can be met.  $t_{RCD(MAX.)}$  is specified as a reference point only. If  $t_{RCD}$  is greater than the specified  $t_{RCD(MAX.)}$  limit, then access time is controlled by  $t_{CAC}$ .
10. Operation within the  $t_{RAD(MAX.)}$  limit ensures that  $t_{RAC(MAX.)}$  can be met.  $t_{RAD(MAX.)}$  is specified as a reference point only. If  $t_{RAD}$  is greater than the specified  $t_{RAD(MAX.)}$  limit, then access time is controlled by  $t_{AA}$ .
11. Either  $t_{RCH}$  or  $t_{RRH}$  must be satisfied for a read cycle.
12.  $t_{OFF(MAX.)}$ ,  $t_{OEZ(MAX.)}$  define the time at which the output achieves the open-circuit conditions and are not referenced to output voltage levels.  $t_{OFF}$  is referenced from the rising edge of  $\overline{RAS}$  or  $\overline{CAS}$ , whichever occurs last.
13. Either  $t_{DZC}$  or  $t_{DZO}$  must be satisfied.
14. Either  $t_{CDD}$  or  $t_{ODD}$  must be satisfied.
15.  $t_{WCS}$ ,  $t_{RWD}$ ,  $t_{CWD}$  and  $t_{AWD}$  are not restrictive operating parameters. They are included in the data sheet as electrical characteristics only. If  $t_{WCS} > t_{WCS(MIN.)}$ , the cycle is an early write cycle and data out pin will remain open-circuit (high impedance) through the entire cycle; if  $t_{RWD} > t_{RWD(MIN.)}$ ,  $t_{CWD} > t_{CWD(MIN.)}$  and  $t_{AWD} > t_{AWD(MIN.)}$ , the cycle is a read-write cycle and I/O will contain data read from the selected cells. If neither of the above sets of conditions is satisfied, the condition of I/O (at access time) is indeterminate.
16. These parameters are referenced to the  $\overline{CAS}$  leading edge in early write cycles and to the  $\overline{WE}$  leading edge in read-write cycles.

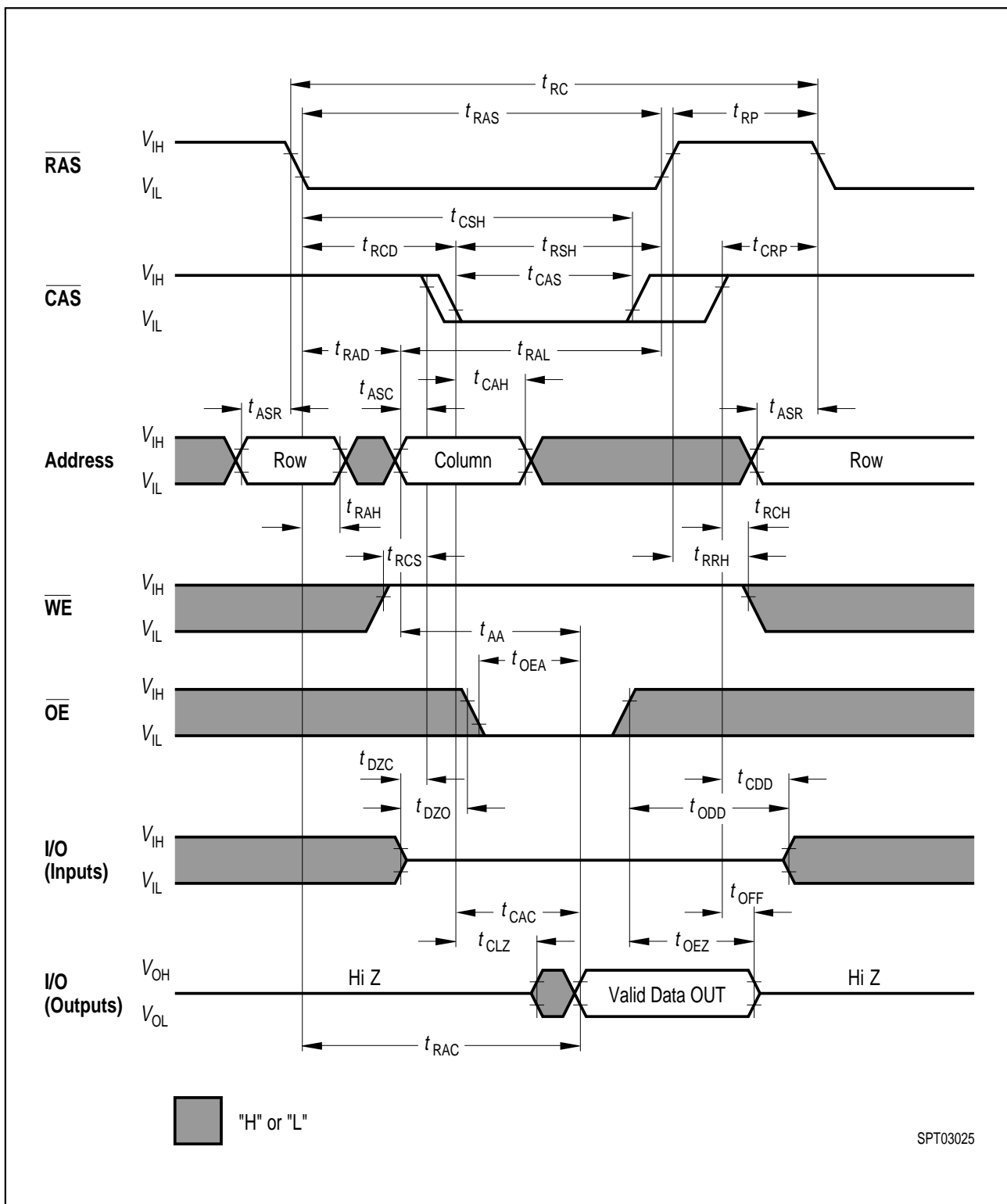

Read Cycle

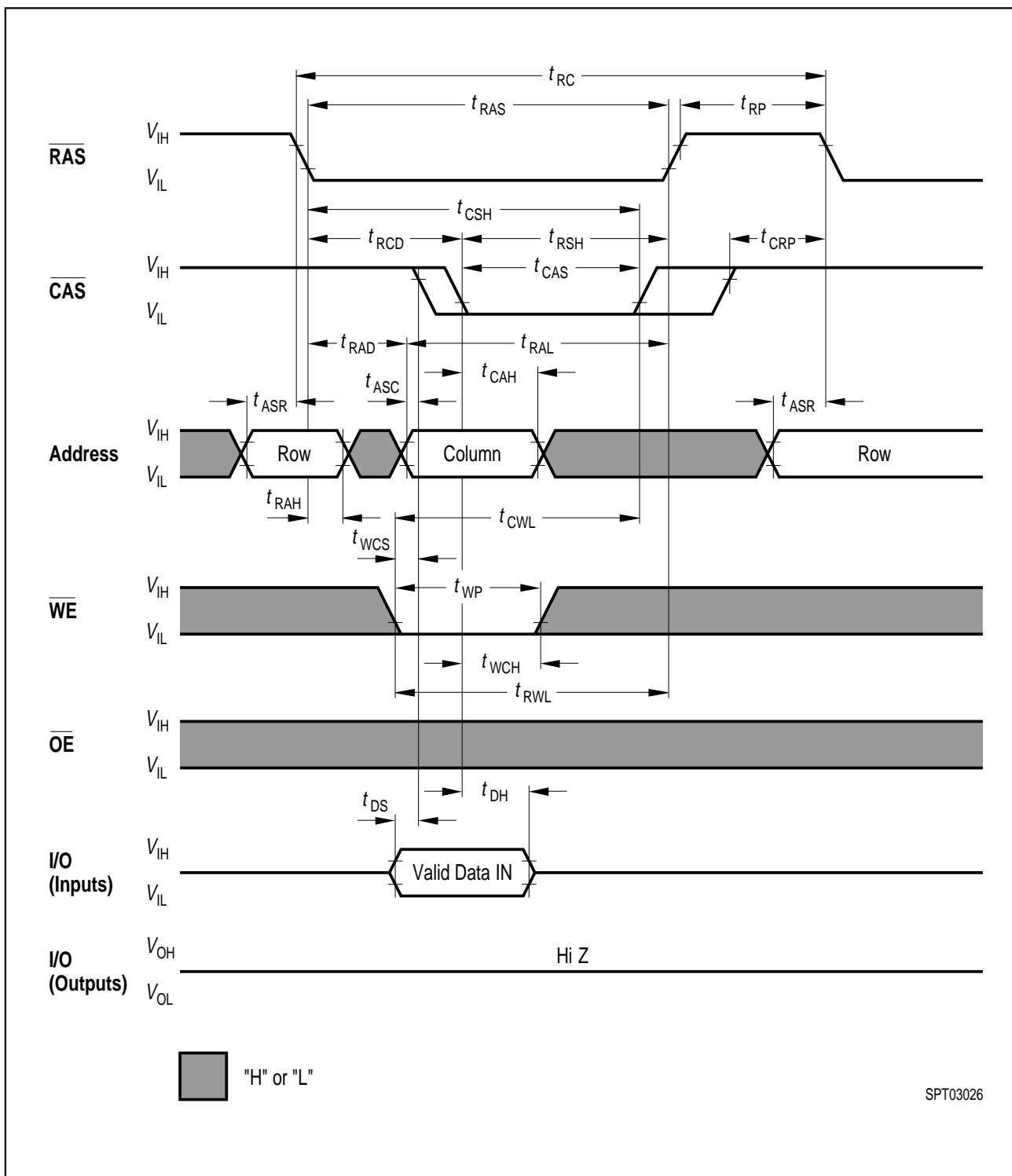

Write Cycle (Early Write)

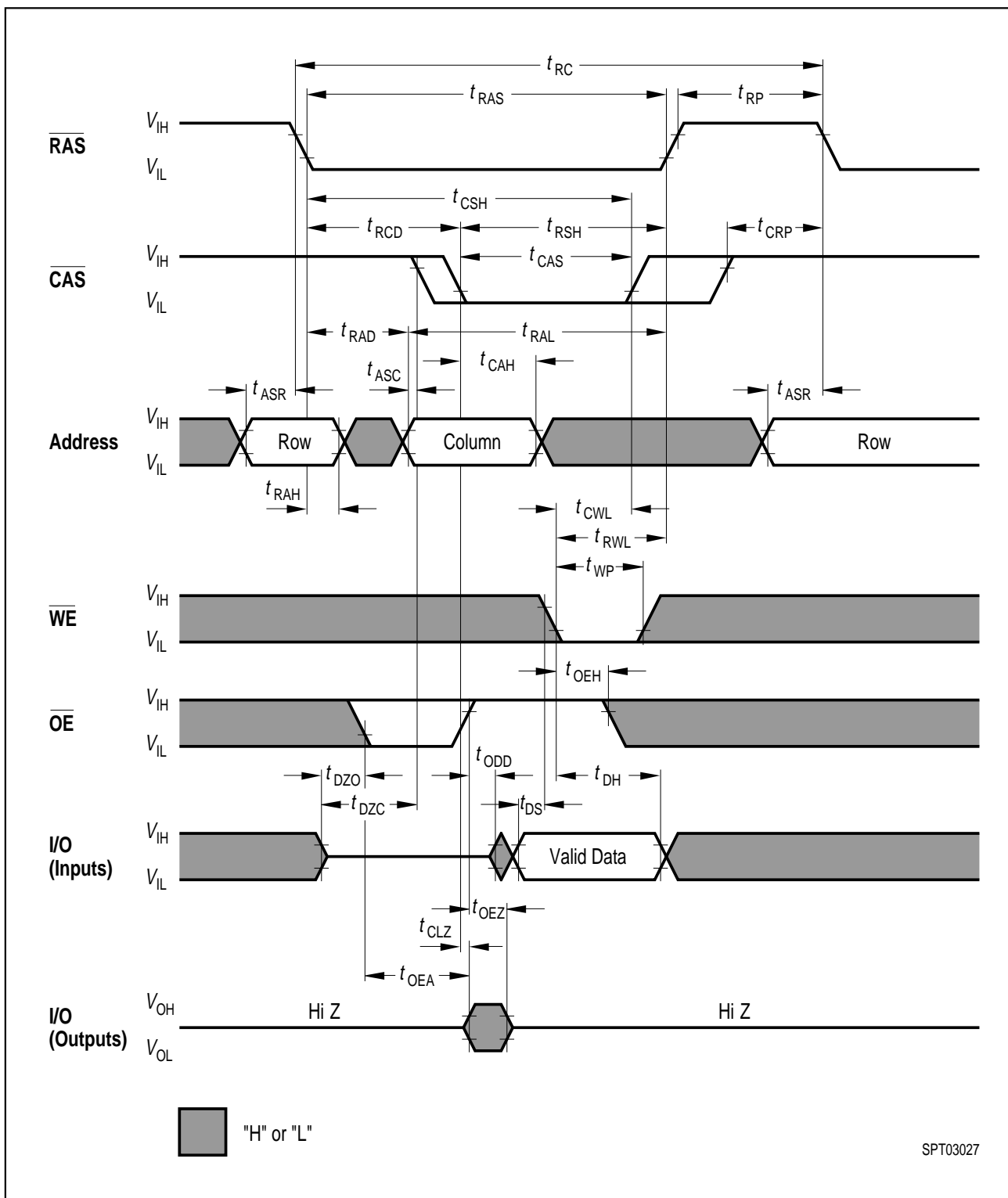

Write Cycle ( $\overline{OE}$  Controlled Write)

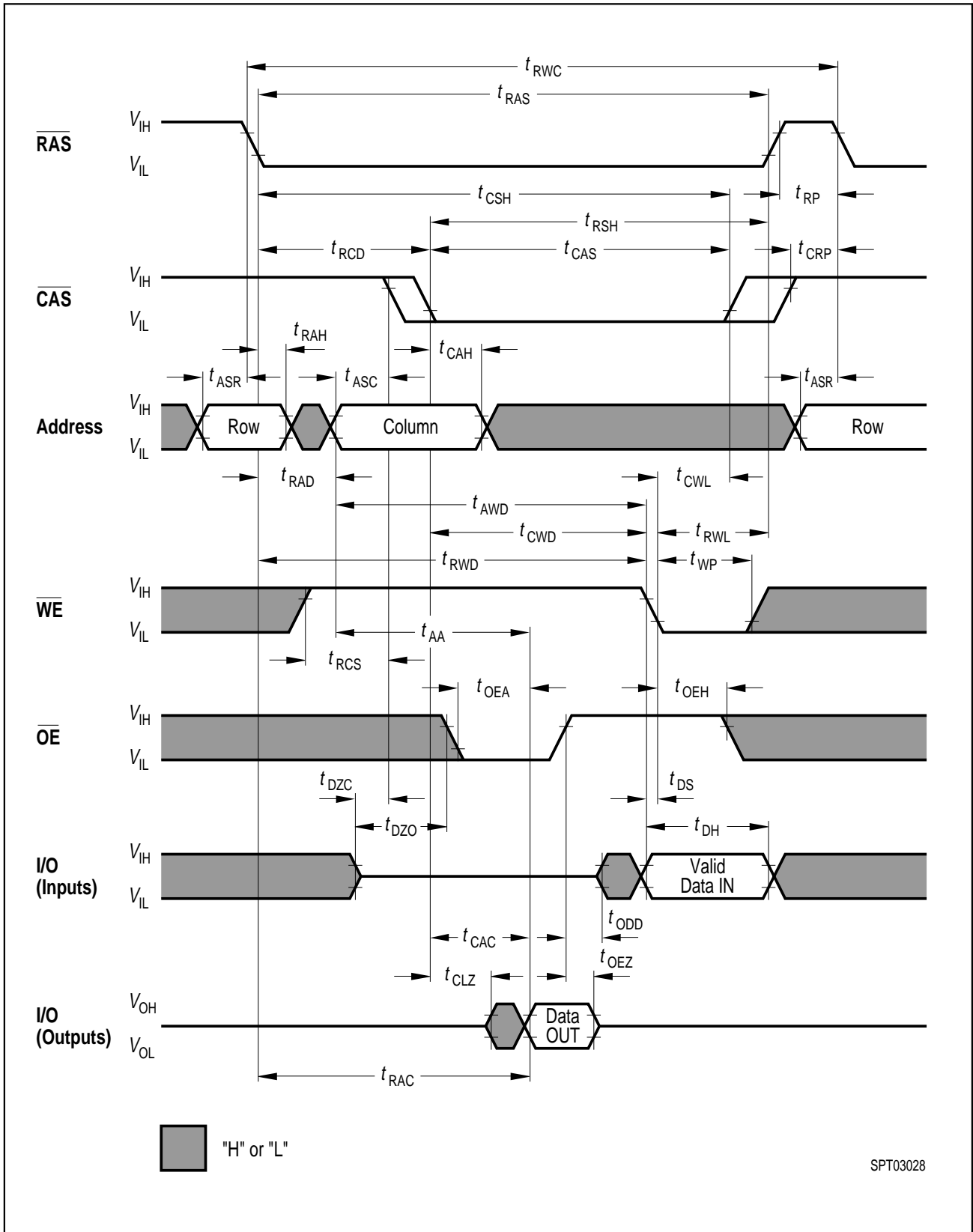

Read-Write (Read-Modify-Write) Cycle

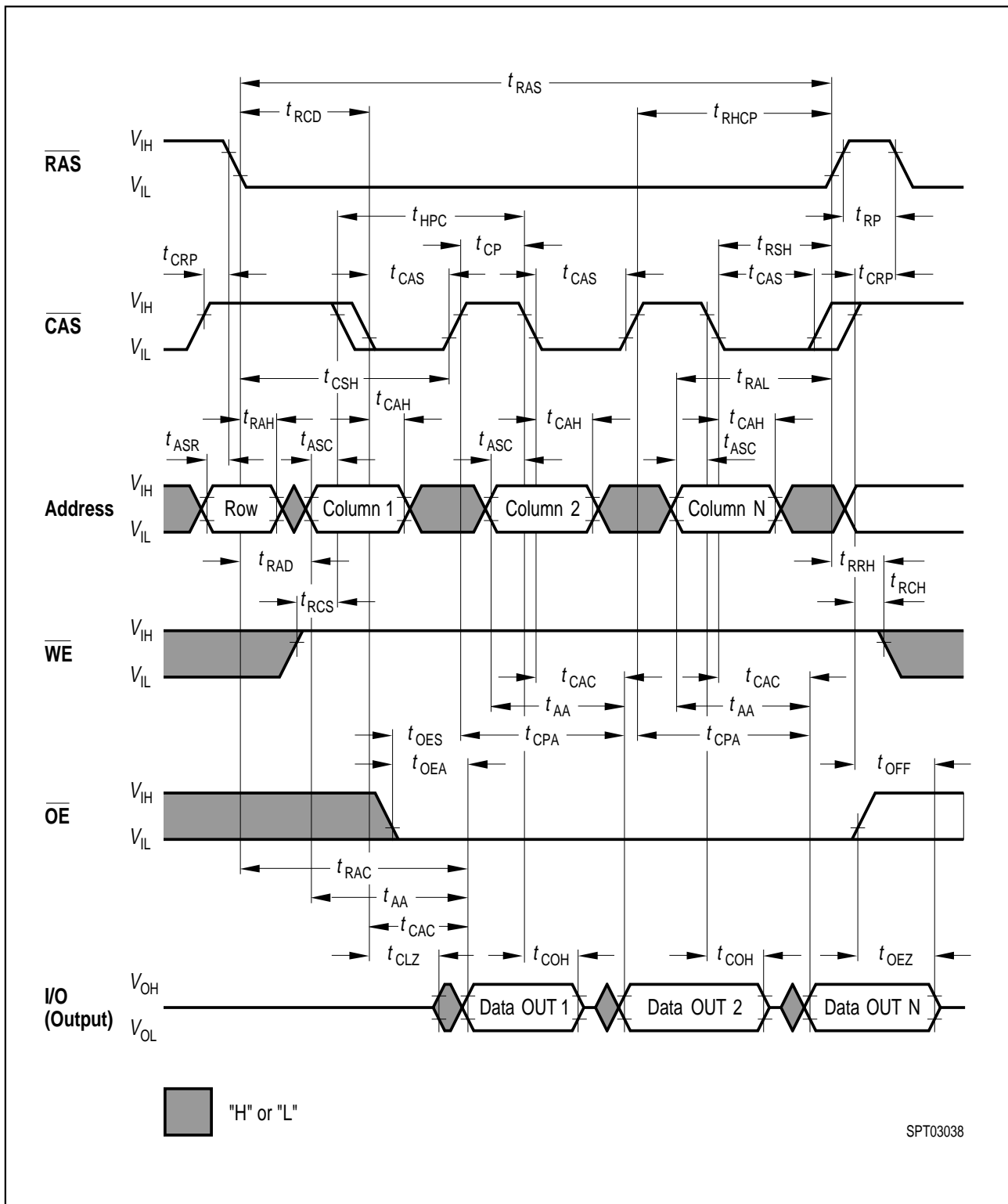

Hyper Page Mode (EDO) Read Cycle





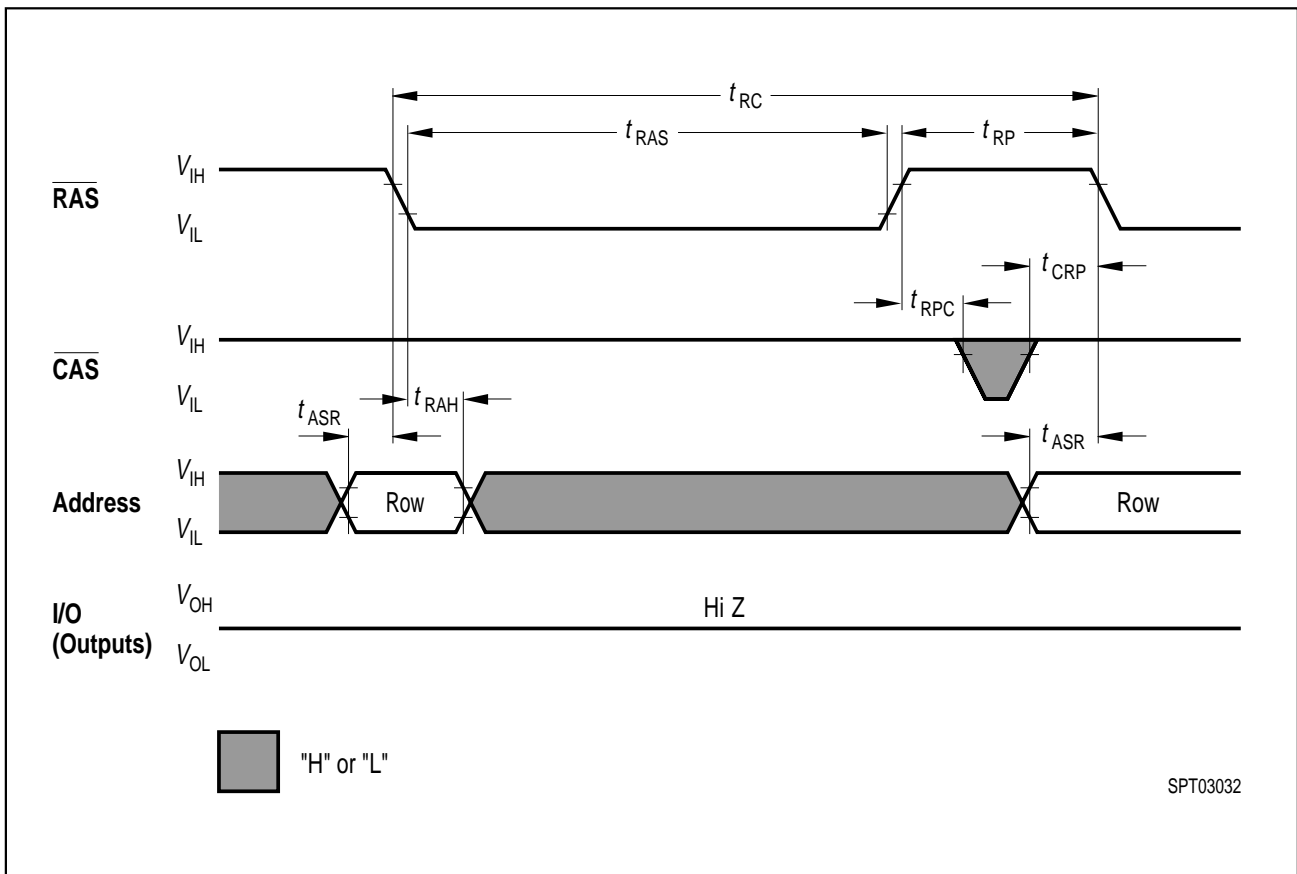

RAS-only Refresh Cycle

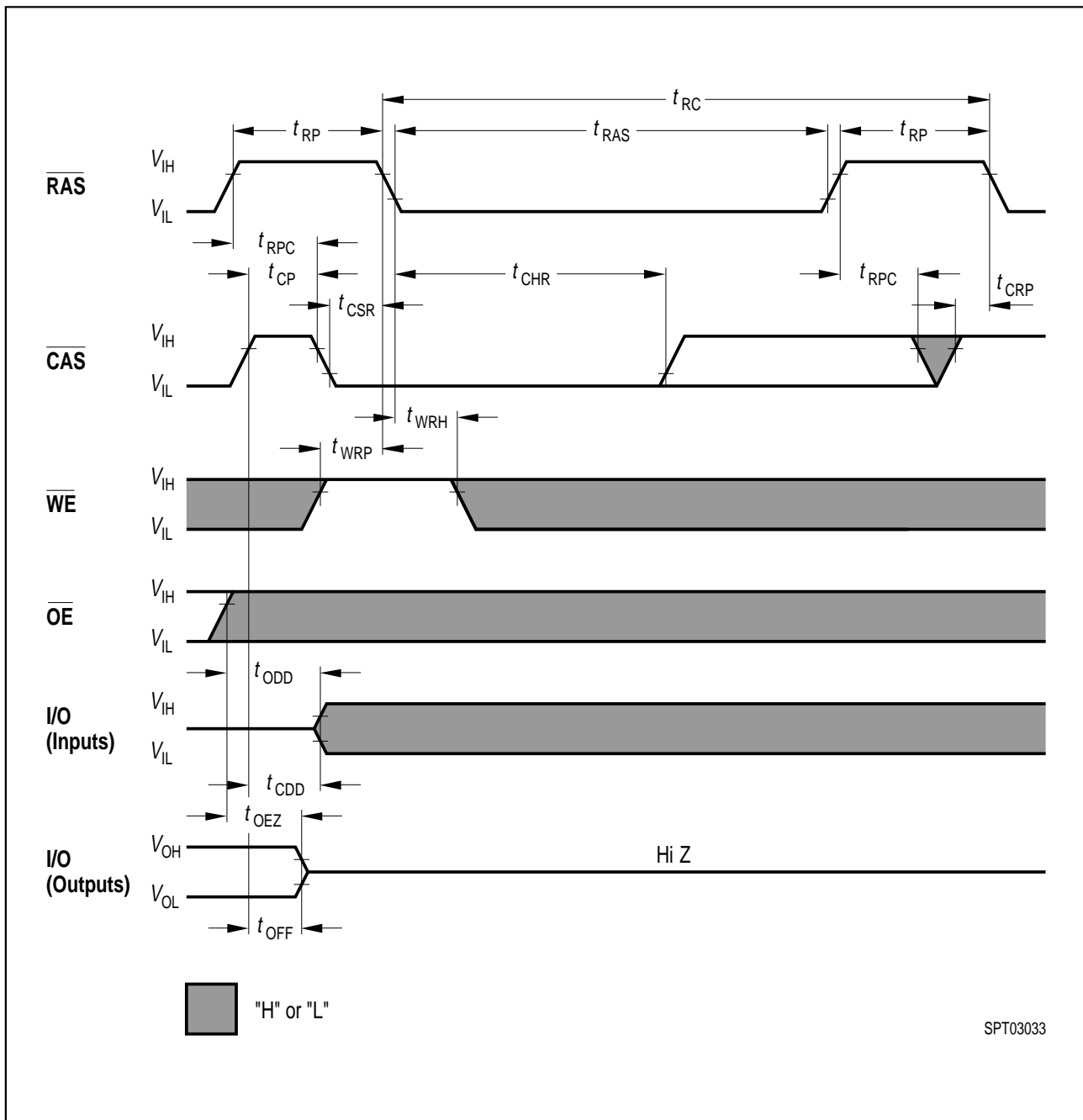

CAS-before-RAS Refresh Cycle

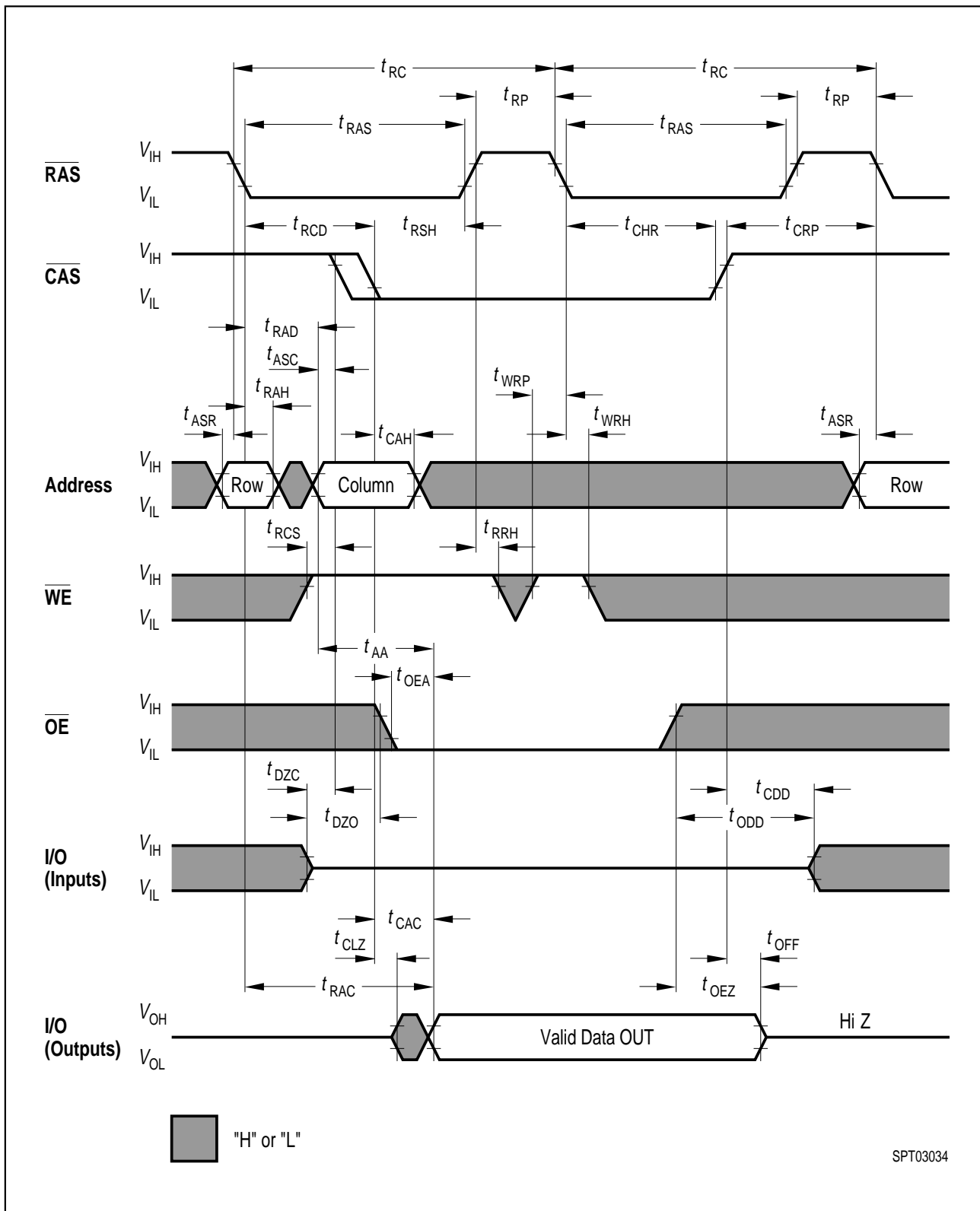

Hidden Refresh Cycle (Read) Cycle

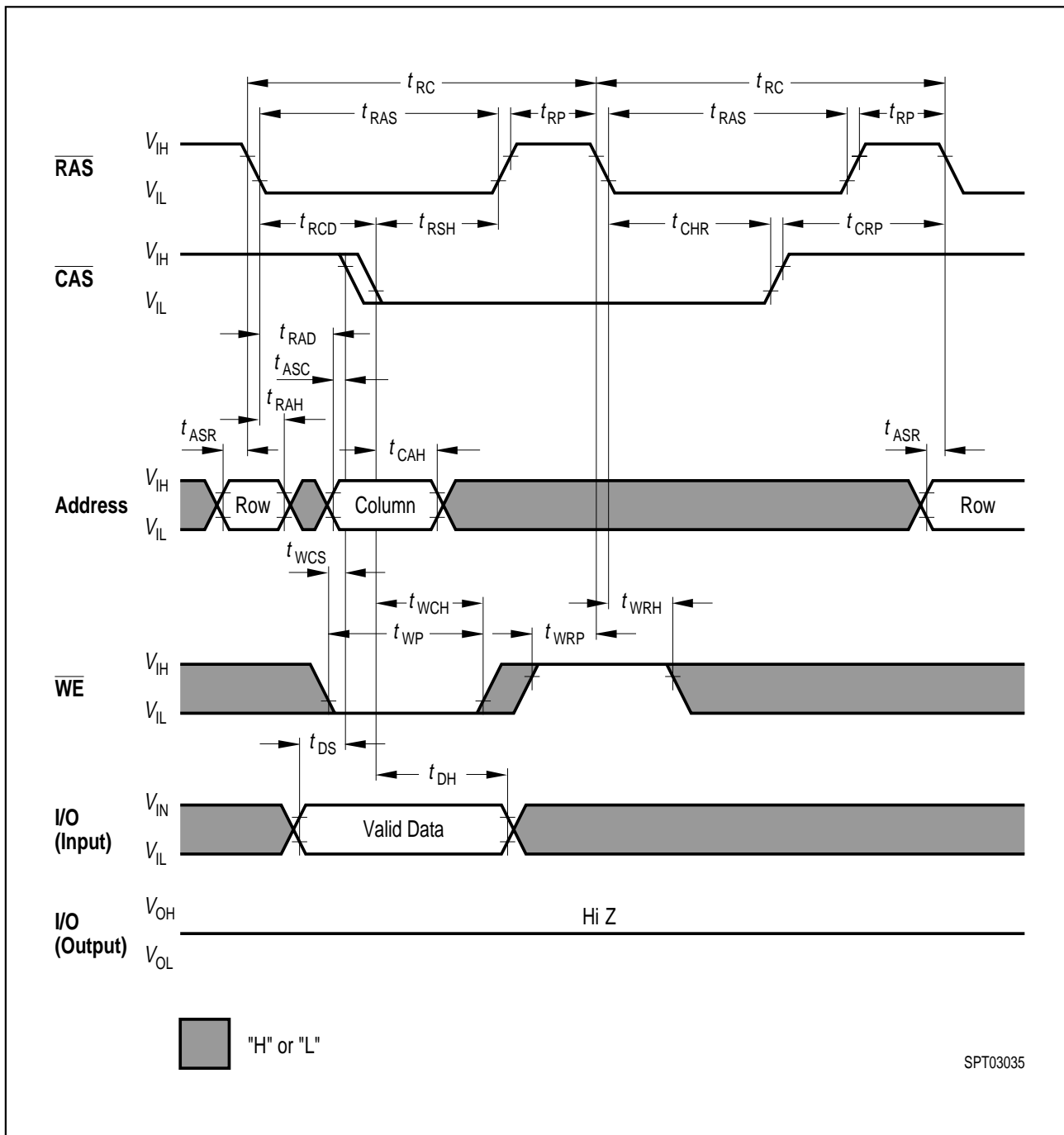

Hidden Refresh Early Write Cycle

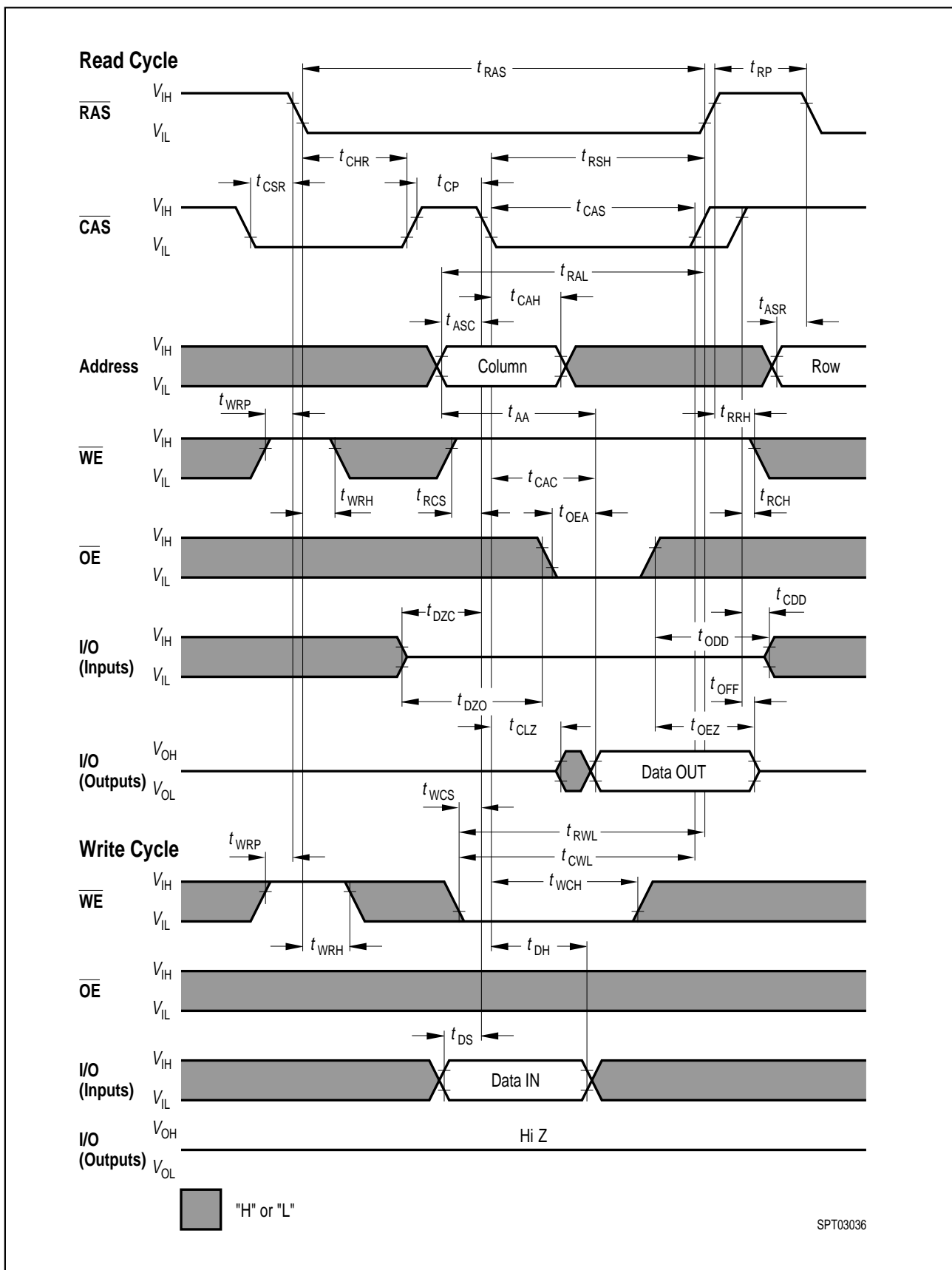

CAS-before-RAS Refresh Counter Test Cycle

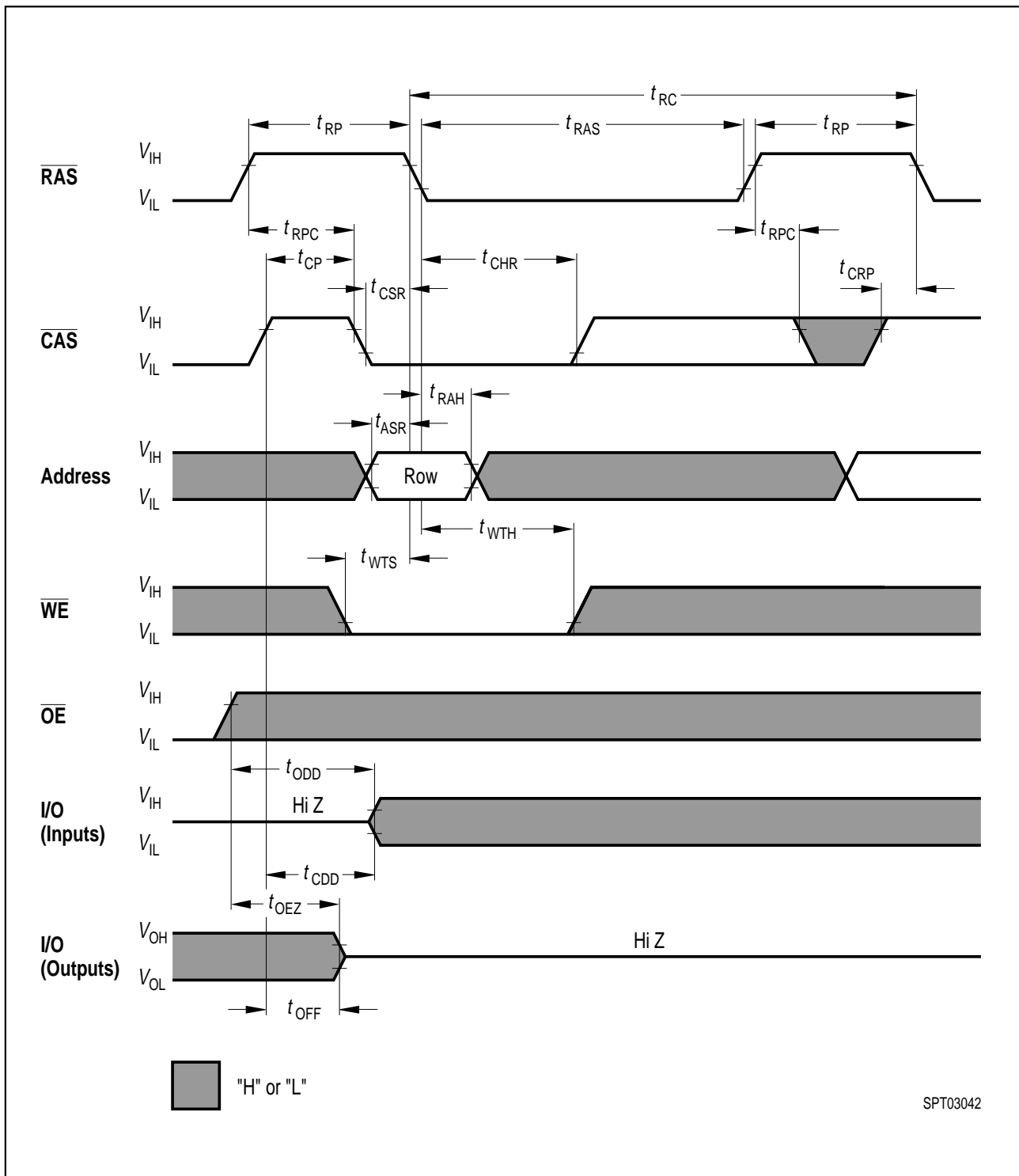

**Test Mode Entry**

**Package Outlines**

**Plastic Package P-SOJ-28-3 (400mil) (SMD)**  
(Plastic small outline J-leaded)

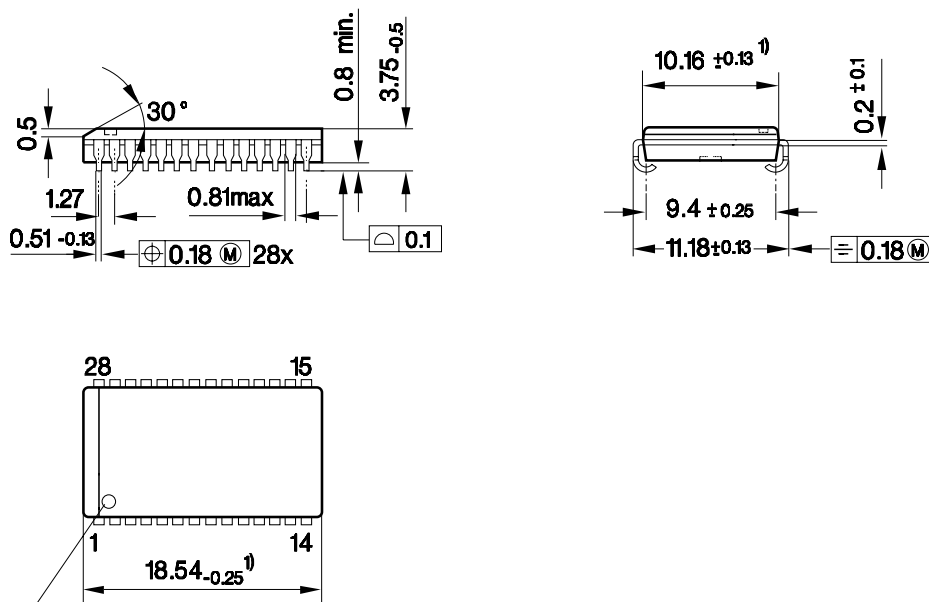

Index Marking

1) Does not include plastic or metal protrusion of 0.15 max. per side

GPJ05699

**Sorts of Packing**

Package outlines for tubes, trays etc. are contained in our Data Book "Package Information".

**SMD = Surface Mounted Device**

Dimensions in mm



LittleDiode supplies new, hard to find or obsolete electronic components and semiconductors all over the world.

With over two million different components listed you are sure to find the part you need.

Feel free to visit us today at our online store:

[LittleDiode.com](http://LittleDiode.com)

Looking forward to providing you with the best possible service.