

SIEMENS

4M x 16-Bit Dynamic RAM

(8k, 4k & 2k Refresh, EDO-version)

HYB 3164165BT(L) -40/-50/-60

HYB 3165165BT(L) -40/-50/-60

HYB 3166165BT(L) -40/-50/-60

Preliminary Information

- 4 194 304 words by 16-bit organization
- 0 to 70 °C operating temperature
- Hyper Page Mode - EDO - operation
- Performance:

		-40	-50	-60	
t_{RAC}	\overline{RAS} access time	40	50	60	ns
t_{CAC}	\overline{CAS} access time	10	13	15	ns
t_{AA}	Access time from address	20	25	30	ns
t_{RC}	Read/write cycle time	69	84	104	ns
t_{HPC}	Hyper page mode (EDO) cycle time	16	20	25	ns

- Single + 3.3 V ($\pm 0.3V$) power supply
- Low power dissipation:

	-40	-50	-60	
HYB3166165BT(L)	864	702	558	mW
HYB3165165BT(L)	486	396	324	mW
HYB3164165BT(L)	306	252	216	mW

- 7.2 mW standby (TTL)
- 3.6 mW standby (MOS)
- 720 μA standby for L-version
- Read, write, read-modify-write, \overline{CAS} -before- \overline{RAS} refresh (CBR), \overline{RAS} -only refresh, hidden refresh and Self Refresh (L-version only)
- 2 \overline{CAS} / 1 \overline{WE} byte control
- 8192 refresh cycles/128 ms , 13 R/ 9C addresses (HYB 3164165BT)
- 4096 refresh cycles/ 64 ms , 12 R/ 10C addresses (HYB 3165165BT)
- 2048 refresh cycles/ 32 ms , 11 R/ 11C addresses (HYB 3166165BT)
- 128 ms refresh period for L-versions
- Plastic Package: P-TSOP11-50 400 mil

This device is a 64 MBit dynamic RAM organized 4 194 304 x 16 bits. The device is fabricated in an advanced first generation 64Mbit 0,35 μ m CMOS silicon gate process technology. The circuit and process design allow this device to achieve high performance and low power dissipation. The HYB3164(5)165BT operates with a single 3.3 +/-0.3V power supply and interfaces with either LVTTTL or LVCMOS levels. Multiplexed address inputs permit the HYB3164(5/6)165BT to be packaged in 400mil wide TSOPII-50 package. These packages provide high system bit densities and are compatible with commonly used automatic testing and insertion equipment. The HYB3164(5/6)165BTL parts have a very low power „sleep mode“ supported by Self Refresh.

Ordering Information

Type	Ordering Code	Package	Descriptions
8k-refresh versions:			
HYB 3164165BT-40		P-TSOPII-50 400 mil	EDO-DRAM (access time 40 ns)
HYB 3164165BT-50		P-TSOPII-50 400 mil	EDO-DRAM (access time 50 ns)
HYB 3164165BT-60		P-TSOPII-50 400 mil	EDO-DRAM (access time 60 ns)
HYB 3164165BTL-50		P-TSOPII-50 400 mil	EDO-DRAM (access time 50 ns)
HYB 3164165BTL-60		P-TSOPII-50 400 mil	EDO-DRAM (access time 60 ns)
4k-refresh versions:			
HYB 3165165BT-40		P-TSOPII-50 400 mil	EDO-DRAM (access time 40 ns)
HYB 3165165BT-50		P-TSOPII-50 400 mil	EDO-DRAM (access time 50 ns)
HYB 3165165BT-60		P-TSOPII-50 400 mil	EDO-DRAM (access time 60 ns)
HYB 3165165BTL-50		P-TSOPII-50 400 mil	EDO-DRAM (access time 50 ns)
HYB 3165165BTL-60		P-TSOPII-50 400 mil	EDO-DRAM (access time 60 ns)
2k-refresh versions:			
HYB 3166165BT-40		P-TSOPII-50 400 mil	EDO-DRAM (access time 40 ns)
HYB 3166165BT-50		P-TSOPII-50 400 mil	EDO-DRAM (access time 50 ns)
HYB 3166165BT-60		P-TSOPII-50 400 mil	EDO-DRAM (access time 60 ns)
HYB 3166165BTL-50		P-TSOPII-50 400 mil	EDO-DRAM (access time 50 ns)
HYB 3166165BTL-60		P-TSOPII-50 400 mil	EDO-DRAM (access time 60 ns)

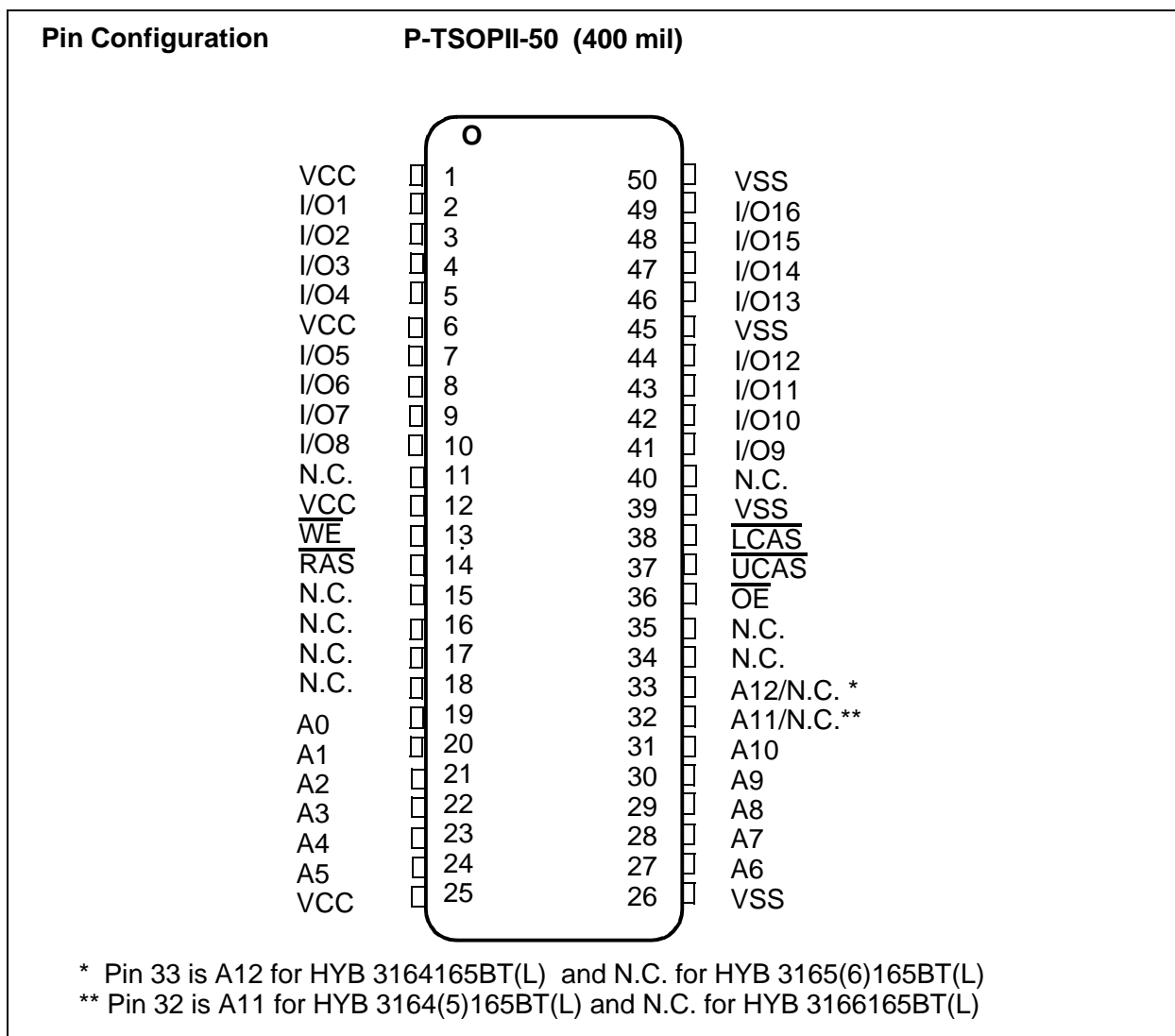

Pin Names

A0-A12	Address Inputs for 8k-refresh version HYB 3164165T(L)
A0-A11	Address Inputs for 4k-refresh version HYB 3165165T(L)
A0-A10	Address Inputs for 2k-refresh version HYB 3166165T(L)
\overline{RAS}	Row Address Strobe
\overline{OE}	Output Enable
I/O1-I/O16	Data Input/Output
\overline{UCAS} , \overline{LCAS}	Column Address Strobe
\overline{WE}	Read/Write Input
Vcc	Power Supply (+ 3.3V)
Vss	Ground

TRUTH TABLE

FUNCTION		$\overline{\text{RAS}}$	$\overline{\text{LCAS}}$	$\overline{\text{UCAS}}$	$\overline{\text{WE}}$	$\overline{\text{OE}}$	ROW ADDR	COL ADDR	I/O1-I/O16
Standby		H	H - X	H - X	X	X	X	X	High Impedance
Read:Word		L	L	H	H	L	ROW	COL	Data Out
Read:Lower Byte		L	L	H	H	L	ROW	COL	Lower Byte:Data Out Upper-Byte:High-Z
Read:Upper Byte		L	H	L	H	L	ROW	COL	Lower Byte:High-Z Upper Byte:Data Out
Write:Word (Early-Write)		L	L	L	L	X	ROW	COL	Data In
Write:Lower Byte (Early-Write)		L	L	H	L	X	ROW	COL	Lower Byte:Data Out Upper-Byte:High-Z
Write:Upper Byte (Early Write)		L	H	L	L	X	ROW	COL	Lower Byte:High-Z Upper Byte:Data Out
Read-Modify-Write		L	L	L	H - L	L - H	ROW	COL	Data Out, Data In
Hyper Page Mode Read (Word)	1st Cycle	L	H - L	H - L	H	L	ROW	COL	Data Out
Hyper Page Mode Read (Word)	2nd Cycle	L	H - L	H - L	H	L	n/a	COL	Data Out
Hyper Page Mode Early Write(Word)	1st Cycle	L	H - L	H - L	L	X	ROW	COL	Data In
Hyper Page Mode Early Write(Word)	2nd Cycle	L	H - L	H - L	L	X	n/a	COL	Data In
Hyper Page Mode RMW	1st Cycle	L	H - L	H - L	H - L	L - H	ROW	COL	Data Out, Data In
Hyper Page Mode RMW	2st Cycle	L	H - L	H - L	H - L	L - H	n/a	COL	Data Out, Data In
$\overline{\text{RAS}}$ only refresh		L	H	H	X	X	ROW	n/a	High Impedance
$\overline{\text{CAS}}$ -before- $\overline{\text{RAS}}$ refresh		H - L	L	L	H	X	X	n/a	High Impedance
Test Mode Entry		H - L	L	L	L	X	X	n/a	High Impedance
Hidden Refresh (Read)		L-H- L	L	L	H	L	ROW	COL	Data Out
Hidden Refresh (Write)		L-H- L	L	L	L	X	ROW	COL	Data In
Self Refresh (L-version only)		H-L	L	H	X	X	X	X	High Impedance

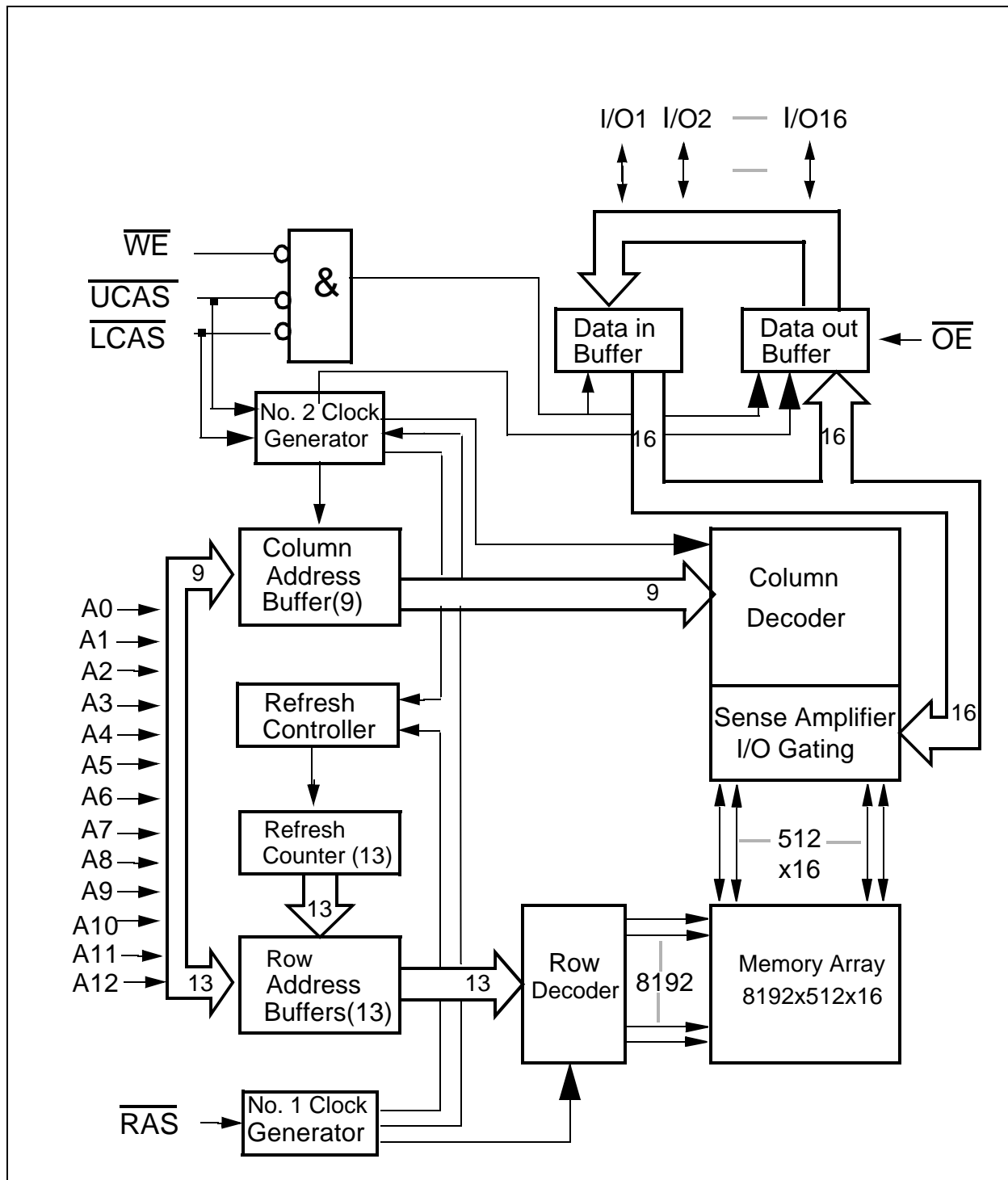

Block Diagram for HYB 3164165BT(L)

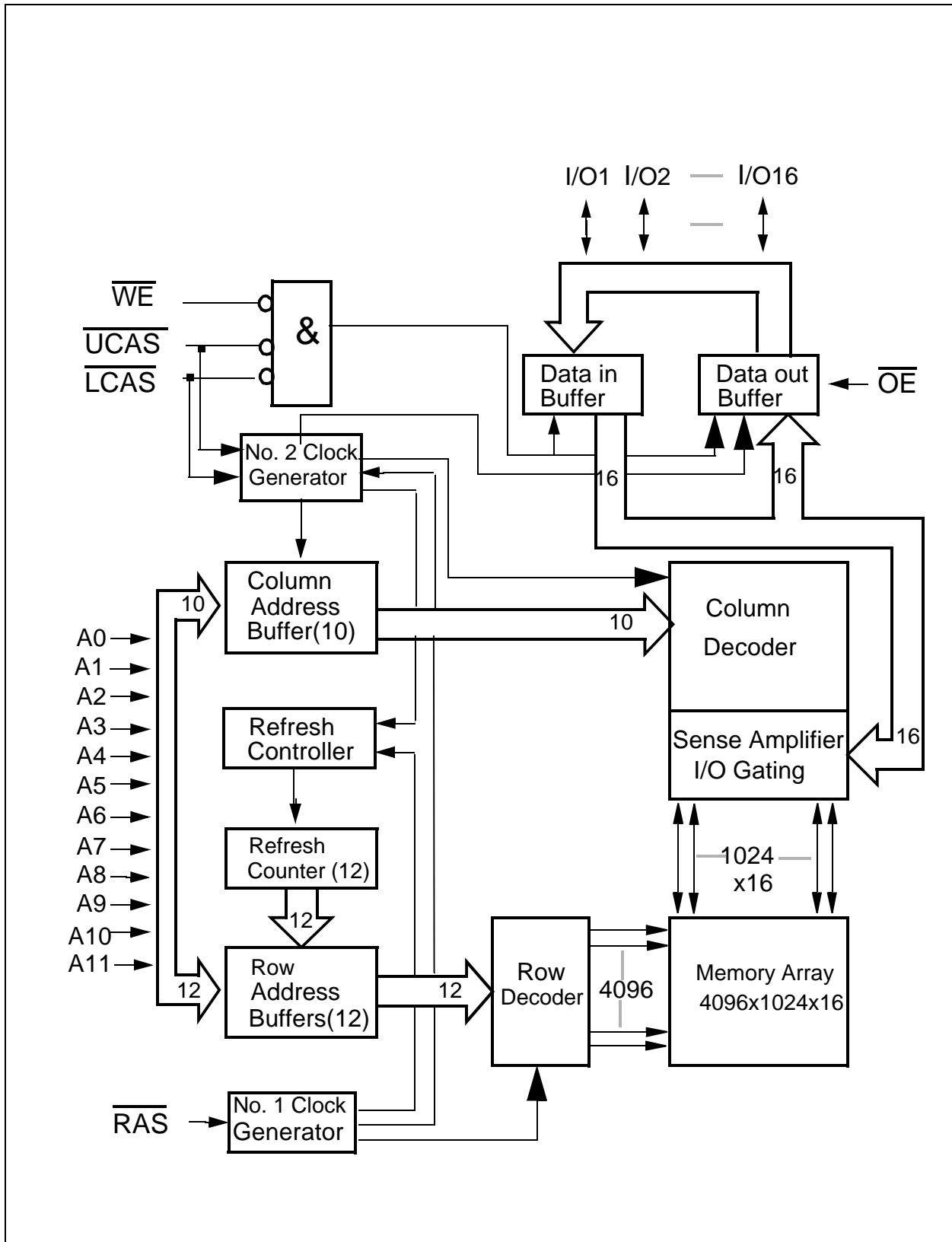

Block Diagram for HYB 3165165BT(L)

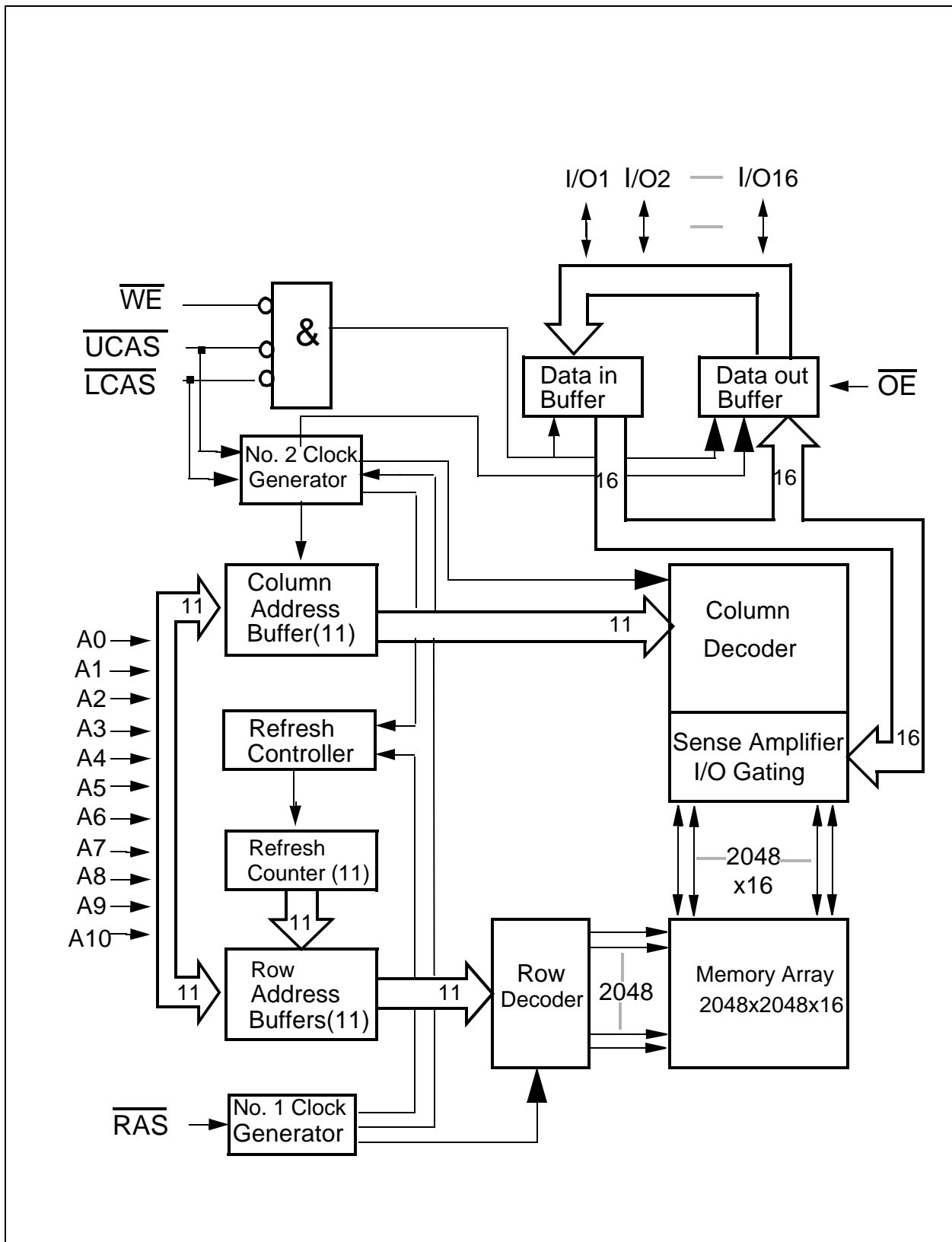

Block Diagram for HYB3166165BT(L)

Absolute Maximum Ratings

Operating temperature range.....	0 to 70 °C
Storage temperature range.....	- 55 to 150 °C
Input/output voltage.....	-0.5 to min (V _{CC} +0.5,4.6) V
Power supply voltage.....	-0.5V to 4.6 V
Power dissipation.....1.1 W
Data out current (short circuit).....	..50 mA

Note

Stresses above those listed under „Absolute Maximum Ratings“ may cause permanent damage of the device. Exposure to absolute maximum rating conditions for extended periods may effect device reliability.

DC Characteristics

$T_A = 0$ to 70 °C, $V_{SS} = 0$ V, $V_{CC} = 3.3$ V \pm 0.3 V

Parameter	Symbol	Limit Values		Unit	Note
		min.	max.		
Input high voltage	V_{IH}	2.0	V _{CC} +0.3	V	1)
Input low voltage	V_{IL}	- 0.3	0.8	V	1)
Output high voltage (LVTTL) Output „H“ level voltage (I _{out} = -2mA)	V_{OH}	2.4	-	V	
Output low voltage (LVTTL) Output „L“ level voltage (I _{out} = +2mA)	V_{OL}	-	0.4	V	
Output high voltage (LVCMOS) Output „H“ level voltage (I _{out} = -100uA)	V_{OH}	V _{CC} -0.2	-	V	
Output low voltage (LVCMOS) Output „L“ level voltage (I _{out} = +100uA)	V_{OL}	-	0.2	V	
Input leakage current, any input (0 V < V _{in} < V _{CC} , all other pins = 0 V)	$I_{I(L)}$	- 2	2	μA	
Output leakage current (DO is disabled, 0 V < V _{out} < V _{CC})	$I_{O(L)}$	- 2	2	μA	

DC-Characteristics (contd)

$T_A = 0$ to 70 °C, $V_{SS} = 0$ V, $V_{CC} = 3.3$ V \pm 0.3 V

Parameter	Symbol	refresh version			Unit	Note
		2k	4k	8k		
Operating Current -40 ns version -50 ns version -60 ns version (\overline{RAS} , \overline{CAS} , address cycling: tRC = tRC min.)	I_{CC1}	240 195 155	135 110 90	85 70 60	mA mA mA	2) 3) 4)
Standby Current (RAS=CAS= Vih)	I_{CC2}	2	2	2	mA	–
\overline{RAS} Only Refresh Current: -40 ns version -50 ns version -60 ns version (RAS cycling: CAS = VIH: tRC = tRC min.)	I_{CC3}	240 195 155	135 110 90	85 70 60	mA mA mA	2) 4)
Hyper Page Mode (EDO) Current: -40 ns version -50 ns version -60 ns version ($\overline{RAS} = V_{IL}$, \overline{CAS} , address cycling: tHPC=tHPC min.)	I_{CC4}	100 65 45	100 65 45	100 65 45	mA mA mA	2) 3) 4)
Standby Current (RAS=CAS= Vcc-0.2V)	I_{CC5}	1	1	1	mA	–
Standby Current (L-Version) ($\overline{RAS}=\overline{CAS}= V_{cc}-0.2V$)	I_{CC5}	200	200	200	μ A	–
\overline{CAS} Before \overline{RAS} Refresh Current -40 ns version -50 ns version -60 ns version (\overline{RAS} , \overline{CAS} cycling: tRC = tRC min.)	I_{CC6}	240 195 155	135 110 90	85 70 60	mA mA mA	2) 4)
Self Refresh Current (L-version only) (CBR cycle with tRAS>TRASSmin, \overline{CAS} held low, $\overline{WE} = V_{cc}-0.2V$, Address and Din= $V_{cc}-0.2V$ or 0.2V)	I_{CC7}	400	400	400	μ A	

Capacitance

$T_A = 0$ to 70 °C, $V_{CC} = 3.3$ V \pm 0.3 V, $f = 1$ MHz

Parameter	Symbol	Limit Values		Unit
		min.	max.	
Input capacitance (A0 to A11,A12)	C_{I1}	–	5	pF
Input capacitance (\overline{RAS} , \overline{CAS} , \overline{WE} , \overline{OE})	C_{I2}	–	7	pF
I/O capacitance (I/O1-I/O16)	C_{I0}	–	7	pF

AC Characteristics ⁵⁾⁶⁾

AC64-2E

$T_A = 0$ to 70 °C, $V_{CC} = 3.3$ V \pm 0.3V, $t_T = 2$ ns

Parameter	Symbol	Limit Values						Unit	Note
		- 40		- 50		- 60			
		min.	max.	min.	max.	min.	max.		

Common Parameters

Random read or write cycle time	t_{RC}	69	–	84	–	104	–	ns	
\overline{RAS} pulse width	t_{RAS}	40	100k	50	100k	60	100k	ns	
\overline{CAS} pulse width	t_{CAS}	6	100k	8	100k	10	100k	ns	
\overline{RAS} precharge time	t_{RP}	25	–	30	–	40	–	ns	
\overline{CAS} precharge time	t_{CP}	6	–	8	–	10	–	ns	
Row address setup time	t_{ASR}	0	–	0	–	0	–	ns	
Row address hold time	t_{RAH}	5	–	7	–	10	–	ns	
Column address setup time	t_{ASC}	0	–	0	–	0	–	ns	
Column address hold time	t_{CAH}	5	–	7	–	10	–	ns	
\overline{RAS} to \overline{CAS} delay time	t_{RCD}	9	30	11	37	14	45	ns	
\overline{RAS} to column address delay time	t_{RAD}	7	20	9	25	12	30	ns	
\overline{RAS} hold time	t_{RSH}	6	–	8	–	10	–	ns	
\overline{CAS} hold time	t_{CSH}	32	–	40	–	48	–	ns	
\overline{CAS} to \overline{RAS} precharge time	t_{CRP}	5	–	5	–	5	–	ns	
Transition time (rise and fall)	t_T	1	50	1	50	1	50	ns	7
Refresh period for 8k-refresh-version	t_{REF}	–	128	–	128	–	128	ms	
Refresh period for 4k-refresh version	t_{REF}	–	64	–	64	–	64	ms	
Refresh period for L-versions	t_{REF}	–	128	–	128	–	128	ms	

Read Cycle

Access time from \overline{RAS}	t_{RAC}	–	40	–	50	–	60	ns	8, 9
Access time from \overline{CAS}	t_{CAC}	–	10	–	13	–	15	ns	8, 9
Access time from column address	t_{AA}	–	20	–	25	–	30	ns	8,10
\overline{OE} access time	t_{OEA}	–	10	–	13	–	15	ns	
Column address to \overline{RAS} lead time	t_{RAL}	20	–	25	–	30	–	ns	
Read command setup time	t_{RCS}	0	–	0	–	0	–	ns	
Read command hold time	t_{RCH}	0	–	0	–	0	–	ns	11

AC Characteristics (cont'd) 5)6)

AC64-2E

 $T_A = 0 \text{ to } 70 \text{ }^\circ\text{C}, V_{CC} = 3.3 \text{ V} \pm 0.3\text{V}, t_T = 2 \text{ ns}$

Parameter	Symbol	Limit Values						Unit	Note
		- 40		- 50		- 60			
		min.	max.	min.	max.	min.	max.		
Read command hold time referenced to $\overline{\text{RAS}}$	t_{RRH}	0	–	0	–	0	–	ns	11
$\overline{\text{CAS}}$ to output in low-Z	t_{CLZ}	0	–	0	–	0	–	ns	8
Output buffer turn-off delay	t_{OFF}	0	10	0	13	0	15	ns	12
Output buffer turn-off delay from $\overline{\text{OE}}$	t_{OEZ}	0	10	0	13	0	15	ns	12
Data to $\overline{\text{CAS}}$ low delay	t_{DZC}	0	–	0	–	0	–	ns	13
Data to $\overline{\text{OE}}$ low delay	t_{DZO}	0	–	0	–	0	–	ns	13
$\overline{\text{CAS}}$ high to data delay	t_{CDD}	10	–	13	–	15	–	ns	14
$\overline{\text{OE}}$ high to data delay	t_{ODD}	10	–	13	–	15	–	ns	14

Write Cycle

Write command hold time	t_{WCH}	5	–	7	–	10	–	ns	
Write command pulse width	t_{WP}	5	–	7	–	10	–	ns	
Write command setup time	t_{WCS}	0	–	0	–	0	–	ns	15
Write command to $\overline{\text{RAS}}$ lead time	t_{RWL}	6	–	8	–	10	–	ns	
Write command to $\overline{\text{CAS}}$ lead time	t_{CWL}	6	–	8	–	10	–	ns	
Data setup time	t_{DS}	0	–	0	–	0	–	ns	16
Data hold time	t_{DH}	5	–	7	–	10	–	ns	16

Read-modify-Write Cycle

Read-write cycle time	t_{RWC}	89	–	109	–	133	–	ns	
$\overline{\text{RAS}}$ to $\overline{\text{WE}}$ delay time	t_{RWD}	52	–	65	–	77	–	ns	15
$\overline{\text{CAS}}$ to $\overline{\text{WE}}$ delay time	t_{CWD}	22	–	28	–	32	–	ns	15
Column address to $\overline{\text{WE}}$ delay time	t_{AWD}	32	–	40	–	47	–	ns	15
$\overline{\text{OE}}$ command hold time	t_{OEH}	5	–	7	–	10	–	ns	

Hyper Page Mode (EDO) Cycle

Hyper page mode (EDO) cycle time	t_{HPC}	16	–	20	–	24	–	ns	
Access time from $\overline{\text{CAS}}$ precharge	t_{CPA}	–	22	–	27	–	32	ns	7
Output data hold time	t_{COH}	3	–	5	–	5	–	ns	

AC Characteristics (cont'd) 5)6)

AC64-2E

 $T_A = 0 \text{ to } 70 \text{ }^\circ\text{C}, V_{CC} = 3.3 \text{ V} \pm 0.3\text{V}, t_T = 2 \text{ ns}$

Parameter	Symbol	Limit Values						Unit	Note
		- 40		- 50		- 60			
		min.	max.	min.	max.	min.	max.		
$\overline{\text{RAS}}$ pulse width in hyper page mode	t_{RAS}	40	200k	50	200k	60	200k	ns	
$\overline{\text{CAS}}$ precharge to $\overline{\text{RAS}}$ Delay	t_{RHPC}	22	–	27	–	32	–	ns	
$\overline{\text{OE}}$ pulse width	t_{OEP}	5	–	5	–	5	–	ns	
$\overline{\text{OE}}$ hold time from $\overline{\text{CAS}}$ high	t_{OEHC}	5	–	5	–	5	–	ns	
Output buffer turn-off delay from $\overline{\text{WE}}$	t_{WEZ}	0	10	0	13	0	15	ns	
$\overline{\text{OE}}$ setup time prior to $\overline{\text{CAS}}$	t_{OES}	5	–	5	–	5	–	ns	

Hyper Page Mode (EDO) Read-modify-Write Cycle

Hyper page mode (EDO) read-write cycle time	t_{PRWC}	44	–	54	–	63	–	ns	
$\overline{\text{CAS}}$ precharge to $\overline{\text{WE}}$	t_{CPWD}	34	–	42	–	49	–	ns	

$\overline{\text{CAS}}$ before $\overline{\text{RAS}}$ Refresh Cycle

$\overline{\text{CAS}}$ setup time	t_{CSR}	5	–	5	–	5	–	ns	
$\overline{\text{CAS}}$ hold time	t_{CHR}	5	–	5	–	10	–	ns	
$\overline{\text{RAS}}$ to $\overline{\text{CAS}}$ precharge time	t_{RPC}	5	–	5	–	5	–	ns	
Write to $\overline{\text{RAS}}$ precharge time	t_{WRP}	5	–	5	–	10	–	ns	
Write hold time referenced to $\overline{\text{RAS}}$	t_{WRH}	5	–	5	–	10	–	ns	

Self Refresh Cycle (L-versions only)

$\overline{\text{RAS}}$ pulse width	t_{RASS}	100k		100k	–	100k	–	ns	17
$\overline{\text{RAS}}$ precharge time	t_{RPS}	69	–	84	–	104	–	ns	17
$\overline{\text{CAS}}$ hold time	t_{CHS}	-50	–	-50	–	-50	–	ns	17

Notes:

- 1) All voltages are referenced to VSS.
Vih may overshoot to Vcc + 2.0 V for pulse widths of < 4ns with 3.3V. Vil may undershoot to -2.0V for pulse width < 4.0 ns with 3.3V. Pulse width measured at 50% points with amplitude measured peak to DC reference.
- 2) ICC1, ICC3, ICC4 and ICC6 and ICC7 depend on cycle rate.
- 3) ICC1 and ICC4 depend on output loading. Specified values are measured with the output open.
- 4) Address can be changed once or less while $\overline{\text{RAS}} = \text{Vil}$. In the case of ICC4 it can be changed once or less during a Hyper page mode cycle (thpc).
- 5) An initial pause of 100 μs is required after power-up followed by 8 $\overline{\text{RAS}}$ -only-refresh cycles, before proper device operation is achieved. In case of using internal refresh counter, a minimum of 8 $\overline{\text{CAS}}$ -before- $\overline{\text{RAS}}$ initialization cycles instead of 8 $\overline{\text{RAS}}$ cycles are required.
- 6) AC measurements assume $t_T = 2 \text{ ns}$.
- 7) VIH (min.) and VIL (max.) are reference levels for measuring timing of input signals. Also, transition times are measured between VIH and VIL.
- 8) Measured with the specified current load and 100 pF at Voh = 2.0 V and Vol = 0.8 V.
- 9) Operation within the tRCD (max.) limit ensures that tRAC (max.) can be met. tRCD (max.) is specified as a reference point only: If tRCD is greater than the specified tRCD (max.) limit, then access time is controlled by tCAC.
- 10) Operation within the tRAD (max.) limit ensures that tRAC (max.) can be met. tRAD (max.) is specified as a reference point only: If tRAD is greater than the specified tRAD (max.) limit, then access time is controlled by tAA.
- 11) Either tRCH or tRRH must be satisfied for a read cycle.
- 12) tOFF (max.) and tOEZ (max.) define the time at which the outputs achieve the open-circuit condition and are not referenced to output voltage levels.
- 13) Either tDZC or tDZO must be satisfied.
- 14) Either tCDD or tODD must be satisfied.
- 15) tWCS, tRWD, tCWD, tAWD and tCPWD are not restrictive operating parameters. They are included in the data sheet as electrical characteristics only. If $tWCS > tWCS(\text{min.})$, the cycle is an early write cycle and the I/O pin will remain open-circuit (high impedance) through the entire cycle; if $tRWD > tRWD(\text{min.})$, $tCWD > tCWD(\text{min.})$, $tAWD > tAWD(\text{min.})$ and $tCPWD > tCPWD(\text{min.})$, the cycle is a read-write cycle and I/O pins will contain data read from the selected cells. If neither of the above sets of conditions is satisfied, the condition of the I/O pins (at access time) is indeterminate.
- 16) These parameters are referenced to $\overline{\text{CAS}}$ leading edge in early write cycles and to $\overline{\text{WRITE}}$ leading edge in Read-Modify-Write cycles.
- 17) When using Self Refresh mode, the following refresh operations must be performed to ensure proper DRAM operation:
If row addresses are being refresh in an evenly distributed manner over the refresh interval using CBR refresh cycles, then only one CBR cycle must be performed immediatly after exit from Self Refresh.
If row addresses are being refresh in any other manner (ROR - Distributed/Burst or CBR-Burst) over the refresh interval, then a full set of row refreshed must be performed immediately before entry to and immediatley after exit from Self Refresh

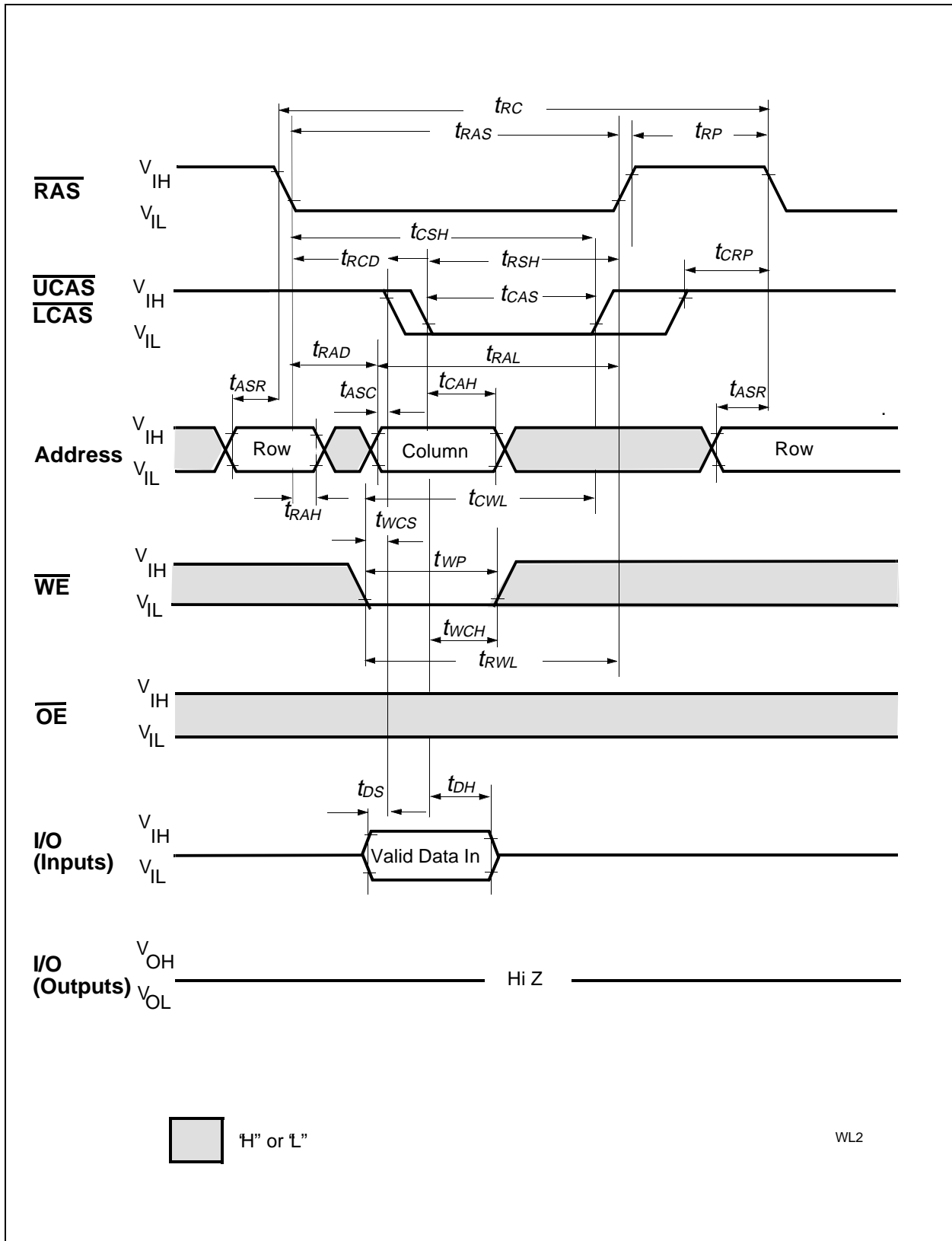

Write Cycle (Early Write)

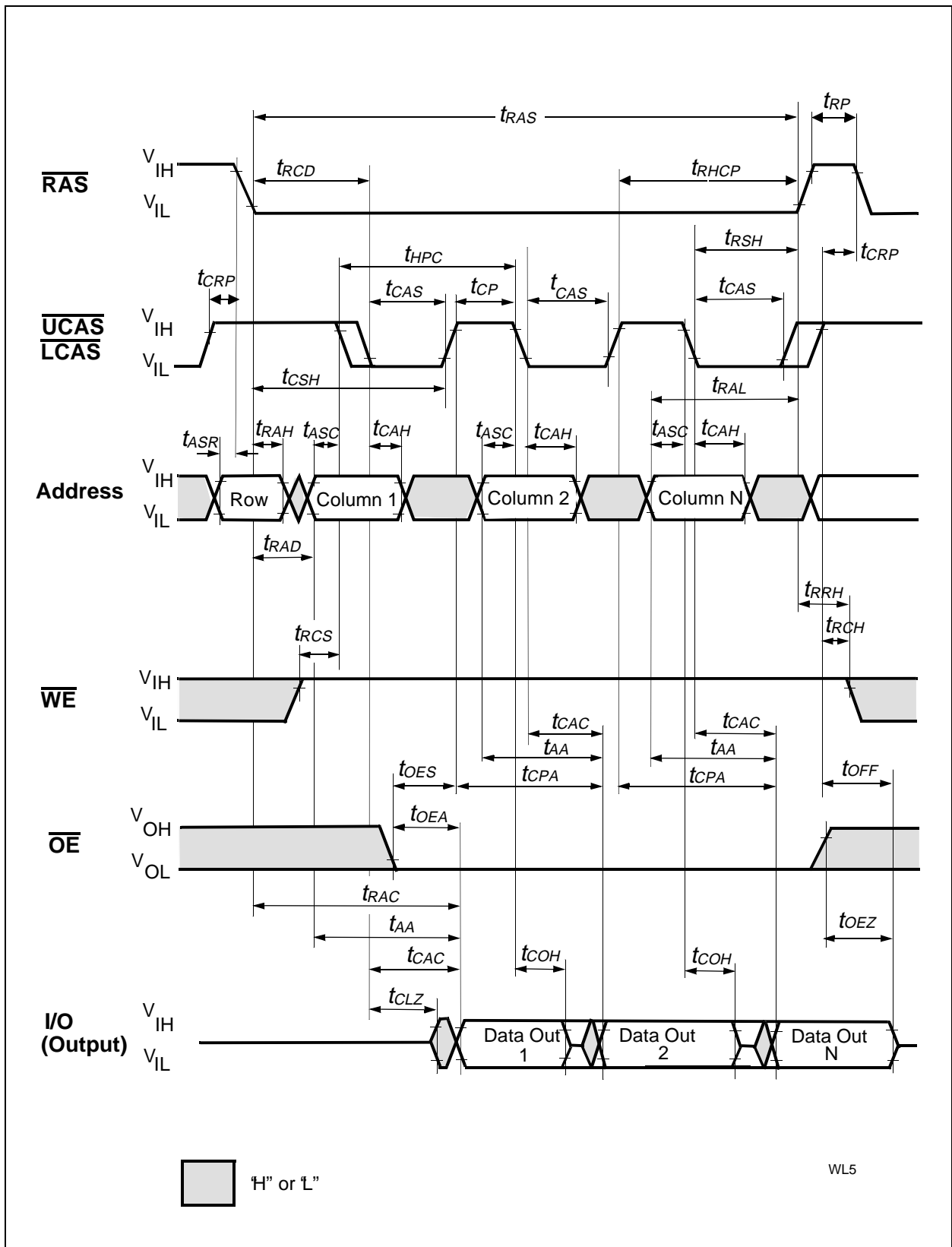

Hyper Page Mode (EDO) Read Cycle

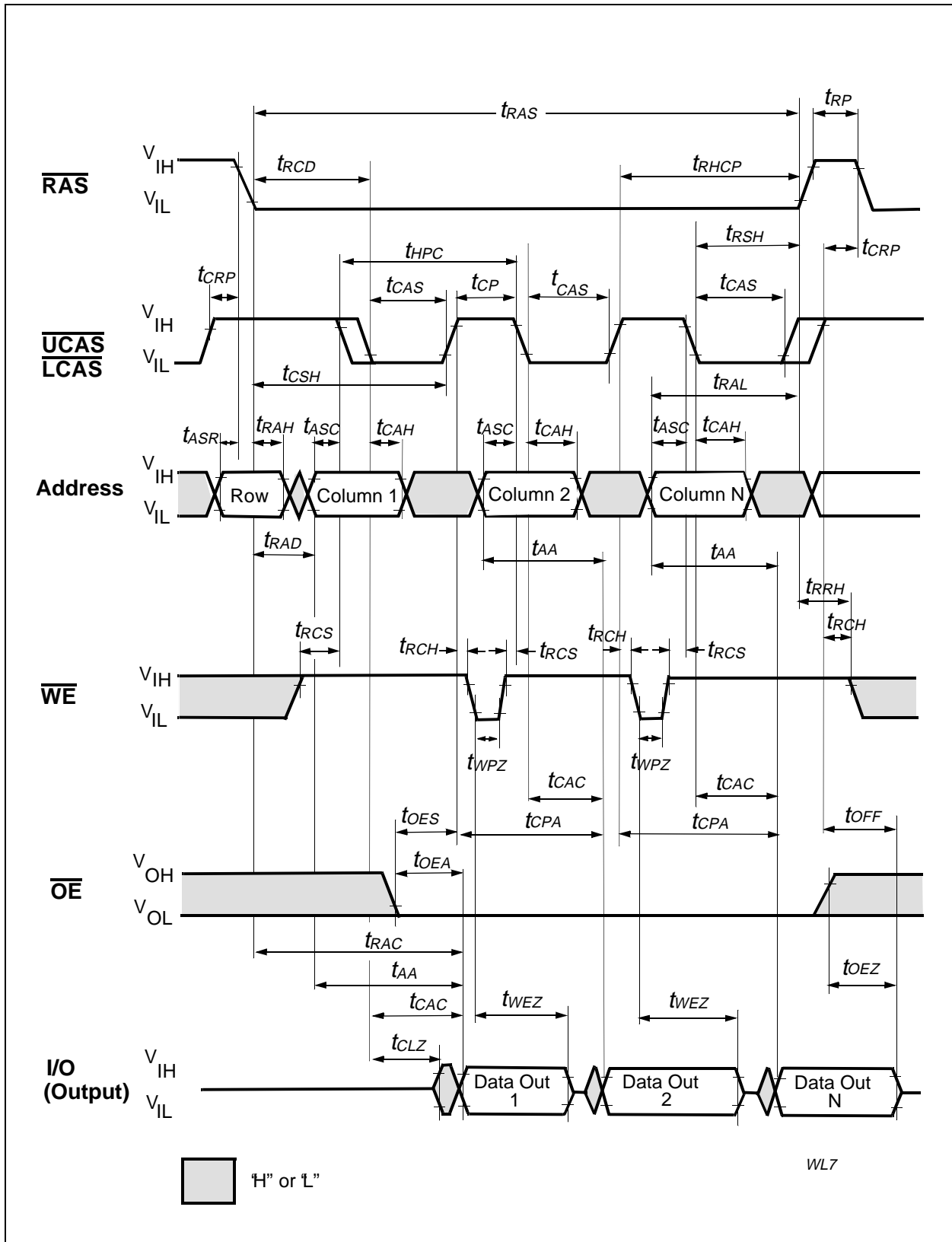

Hyper Page Mode (EDO) Read Cycle (\overline{WE} Control)

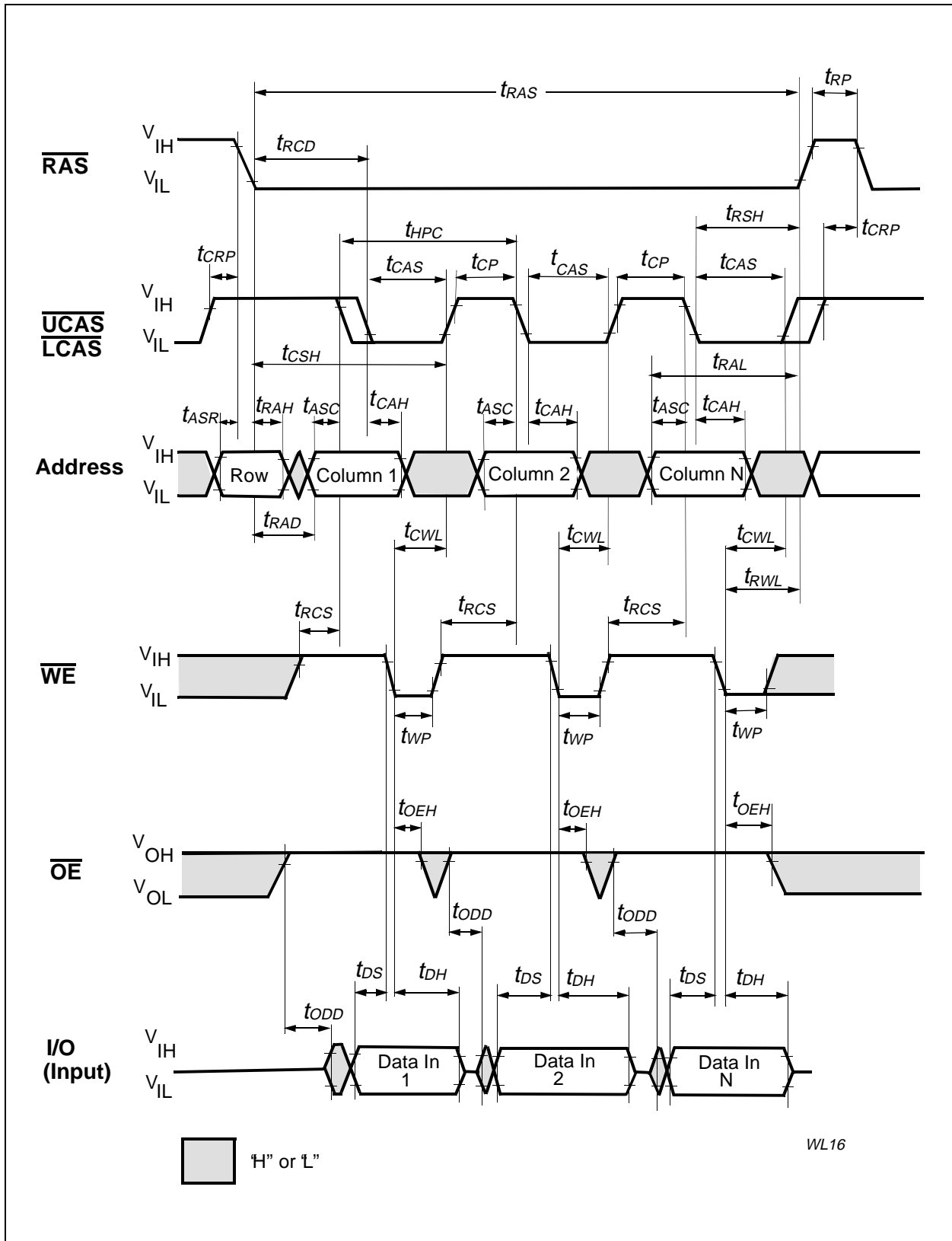

Hyper Page Mode (EDO) Late Write Cycle

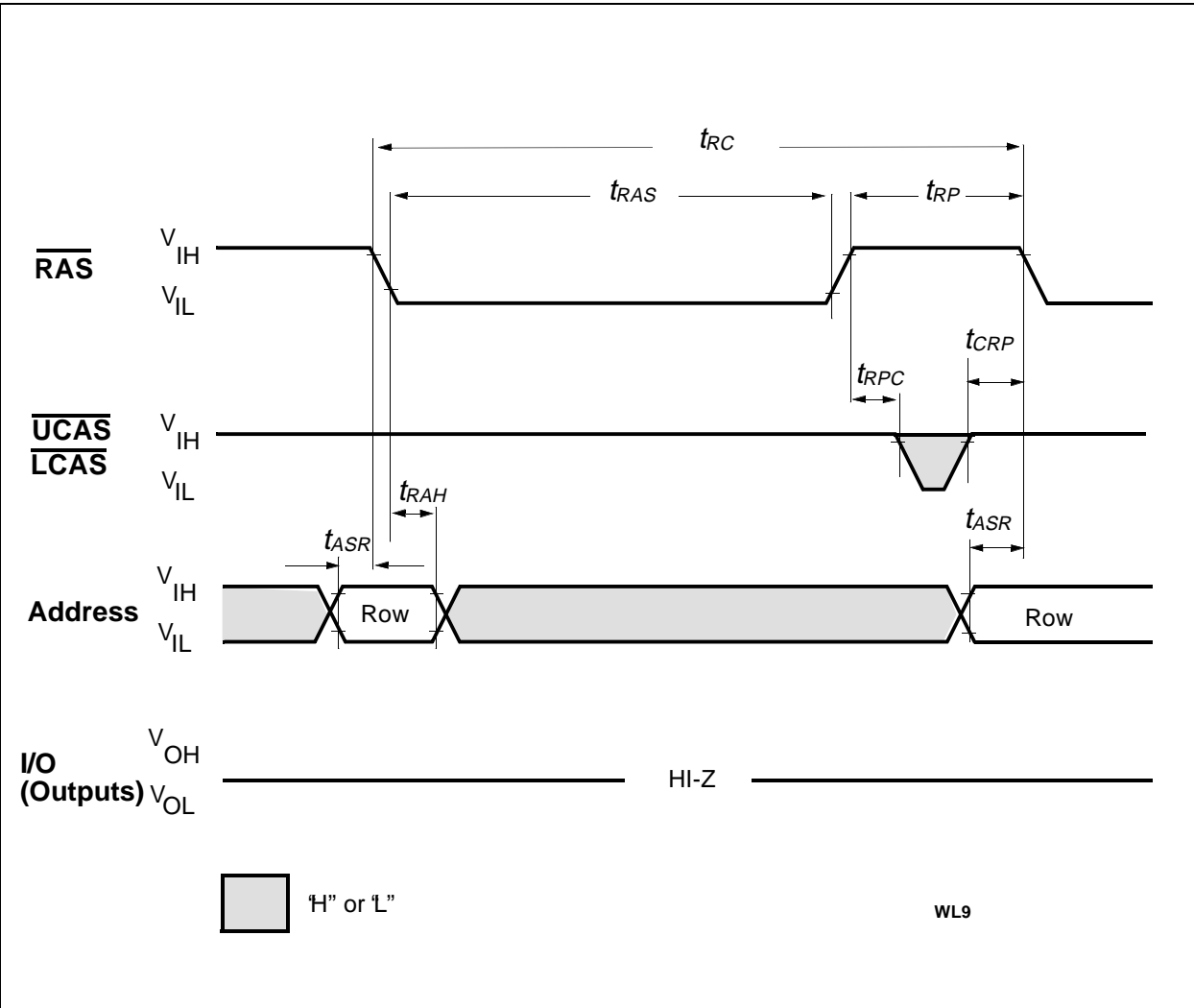

$\overline{\text{RAS}}$ Only Refresh Cycle

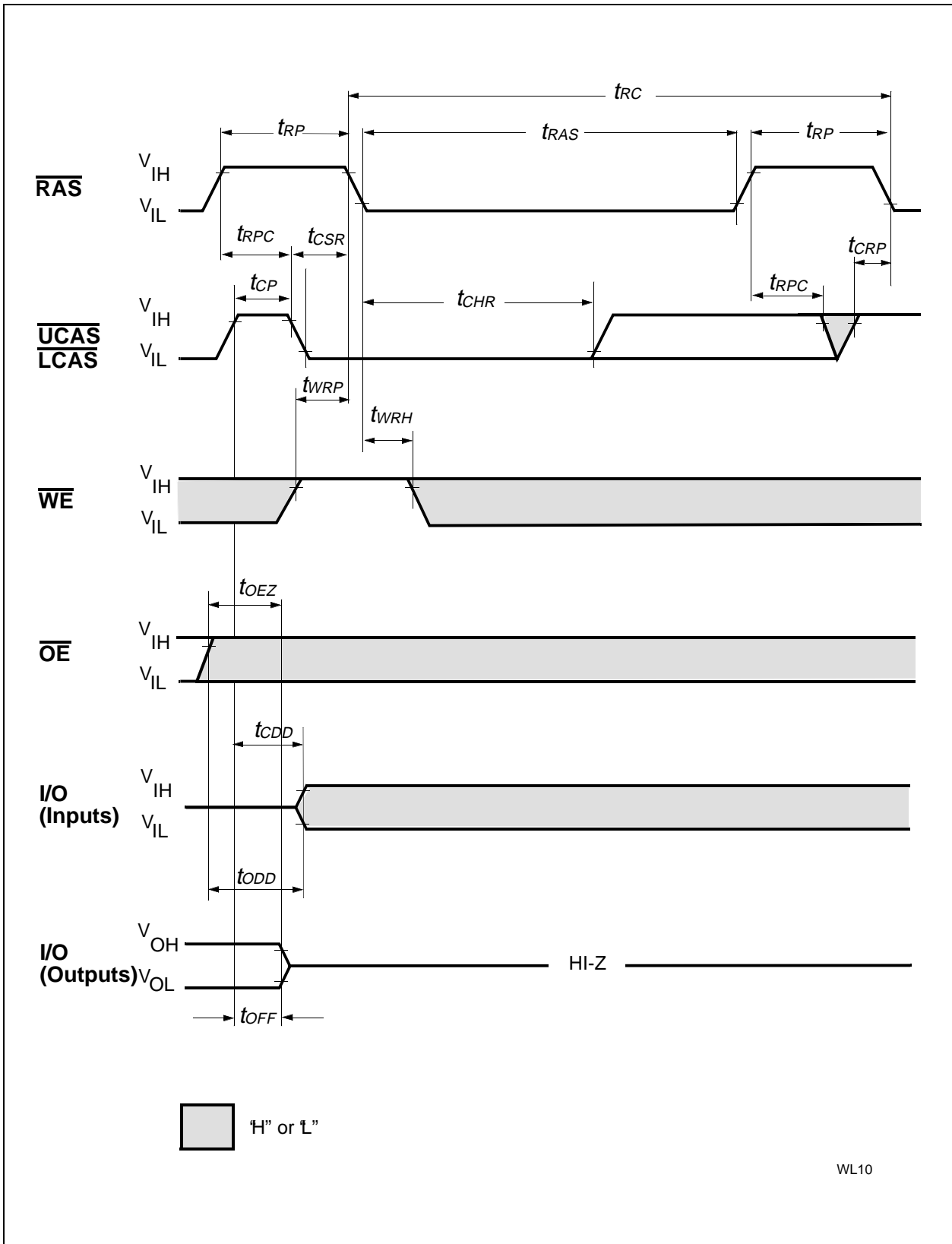

WL10

CAS-before-RAS Refresh Cycle

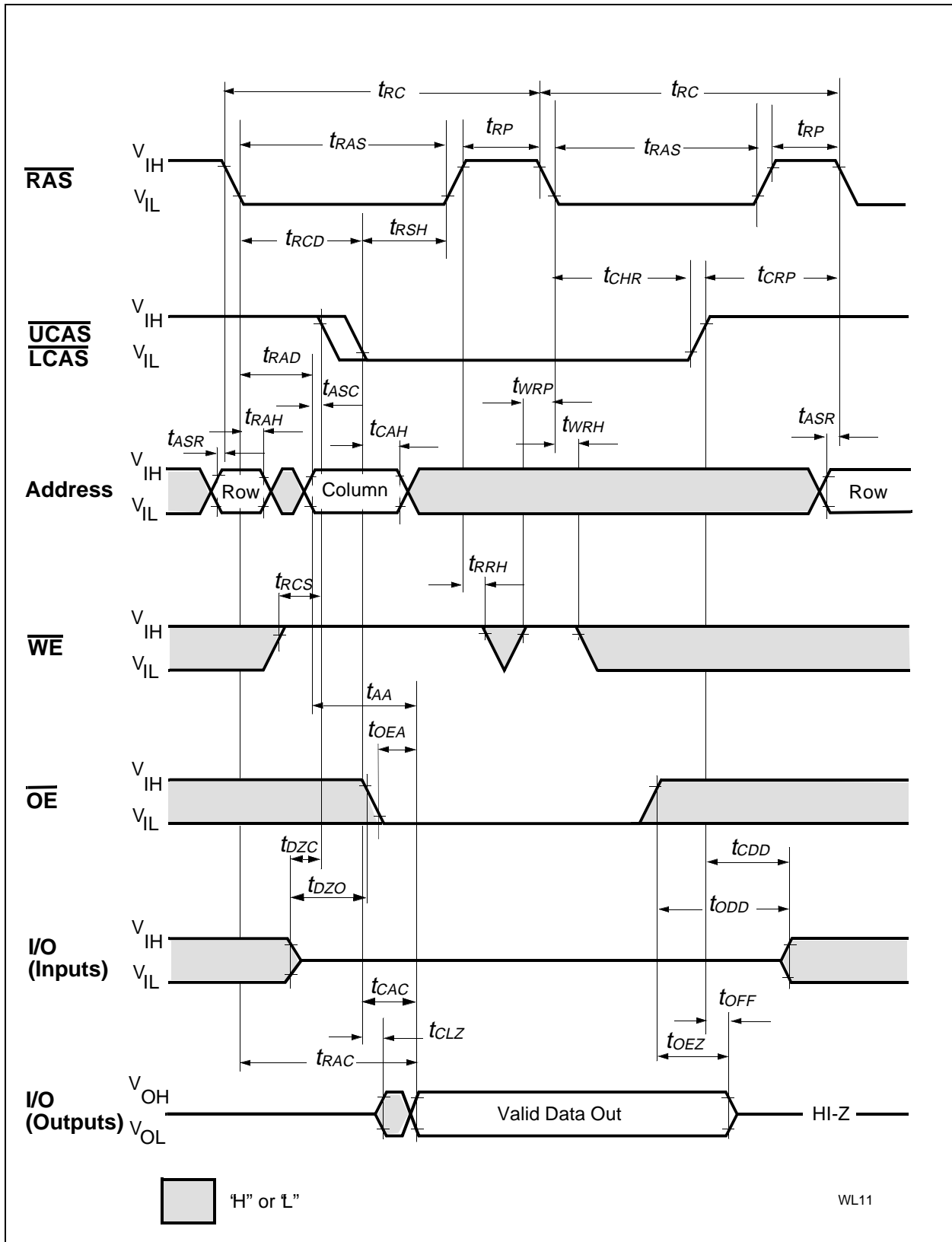

Hidden Refresh Read Cycle

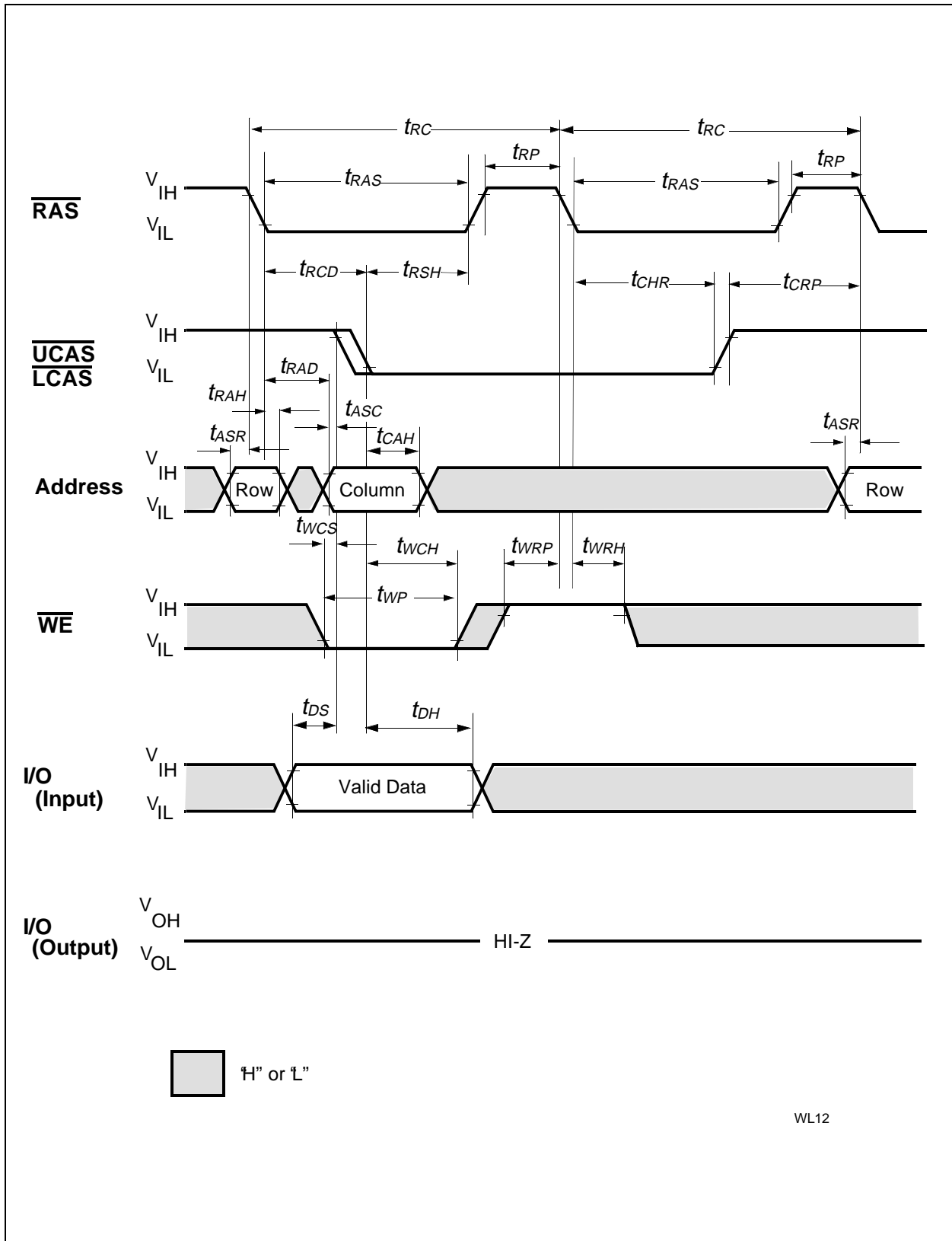

Hidden Refresh Early Write Cycle

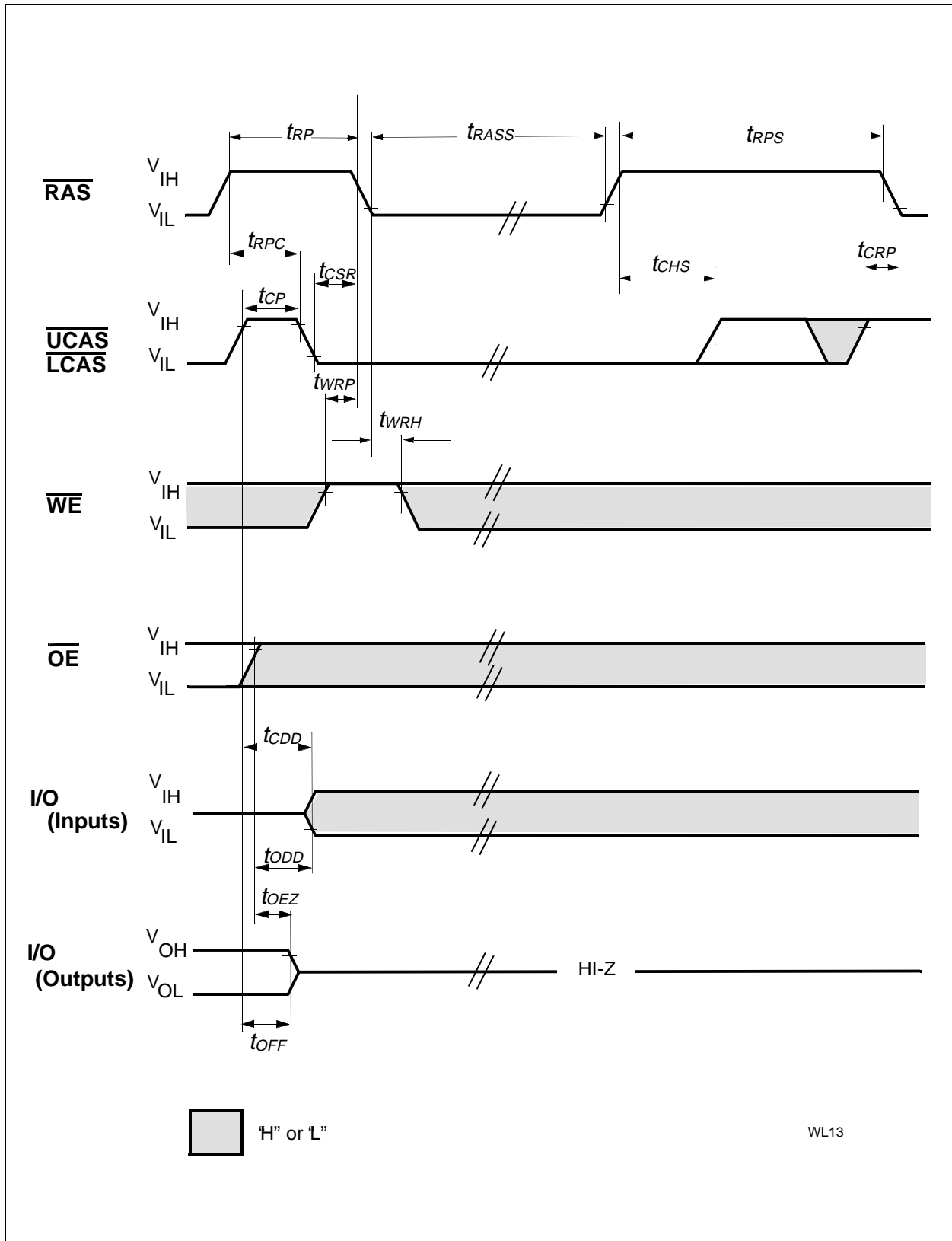

Self Refresh (Sleep Mode)

Package Outlines

Plastic Package P-TSOPII-50 (400 mil)

(Thin Small Outline, SMD)

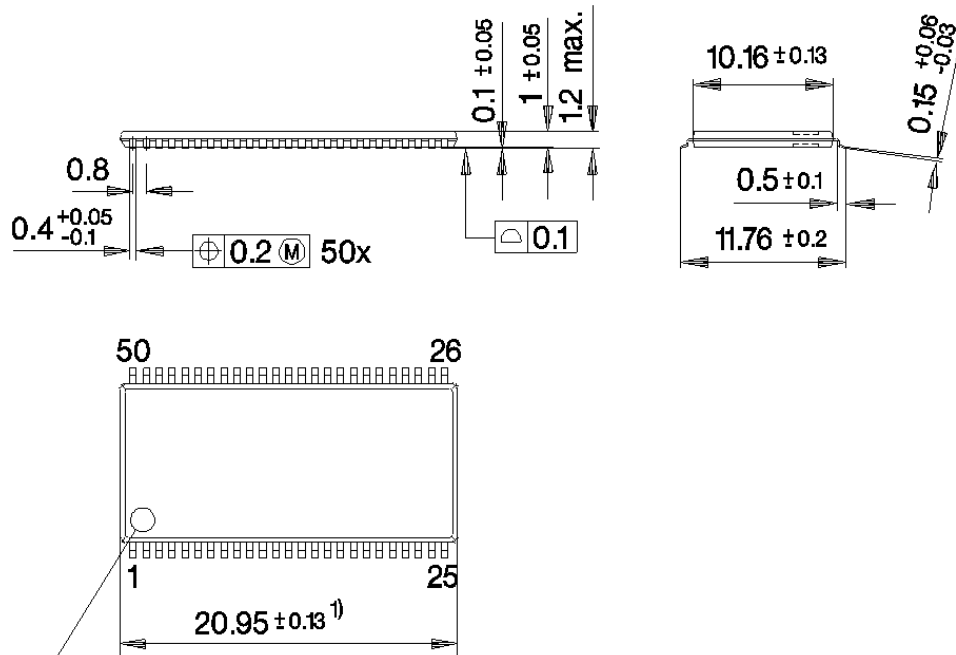

Index Marking

1) Does not include plastic or metal protrusion of 0.25 max. per side



LittleDiode supplies new, hard to find or obsolete electronic components and semiconductors all over the world.

With over two million different components listed you are sure to find the part you need.

Feel free to visit us today at our online store:

LittleDiode.com

Looking forward to providing you with the best possible service.