

4M × 4-Bit Dynamic RAM 2k & 4k Refresh (Fast Page Mode)

HYB 5116400BJ-50/-60
HYB 5117400BJ-50/-60
HYB 3116400BJ/BT-50/-60
HYB 3117400BJ-50/-60

Advanced Information

- 4 194 304 words by 4-bit organization
- 0 to 70 °C operating temperature
- Fast Page Mode operation
- Performance:

		-50	-60	
t_{RAC}	\overline{RAS} access time	50	60	ns
t_{CAC}	\overline{CAS} access time	13	15	ns
t_{AA}	Access time from address	25	30	ns
t_{RC}	Read/Write cycle time	84	104	ns
t_{PC}	Fast page mode cycle time	35	40	ns

- Power Dissipation, Refresh & Addressing:

	HYB 5116400		HYB 3116400		HYB 5117400		HYB 3117400		
	-50	-60	-50	-60	-50	-60	-50	-60	
Power Supply	5 V ± 10%		3.3 V ± 0.3 V		5 V ± 10%		3.3 V ± 0.3 V		
Addressing	12/10		12/10		11/11		11/11		
Refresh	4096 cycles / 64 ms				2048 cycles / 32 ms				
Active	275	220	180	144	440	385	288	252	mW
TTL Standby	11		7.2		11		7.2		mW
CMOS Standby	5.5		3.6		5.5		3.6		mW

- Read, write, read-modify-write, \overline{CAS} -before- \overline{RAS} refresh, \overline{RAS} -only refresh, hidden refresh and test mode
- All inputs, outputs and clocks fully TTL (5 V versions) and LV-TTL (3.3 V version)-compatible
- Plastic Package: P-SOJ-26/24-1 300 mil
P-TSOPII-26/24-1 300 mil

The HYB 5(3)116(7)400 are 16 MBit dynamic RAMs based on die revisions "G" & "F" and organized as 4 194 304 words by 4-bits. The HYB 5(3)116(7)400BJ/BT utilizes a submicron CMOS silicon gate process technology, as well as advanced circuit techniques to provide wide operating margins, both internally and for the system user. Multiplexed address inputs permit the HYB 5(3)116(7)400 to be packaged in a standard SOJ-26/24 and TSOPII-26/24 plastic package with 300 mil width. These packages provide high system bit densities and are compatible with commonly used automatic testing and insertion equipment.

Ordering Information

Type	Ordering Code	Package	Descriptions
2k-Refresh Versions			
HYB 5117400BJ-50	Q67100-Q1086	P-SOJ-26/24-1 300 mil	5 V 50 ns FPM-DRAM
HYB 5117400BJ-60	Q67100-Q1087	P-SOJ-26/24-1 300 mil	5 V 60 ns FPM-DRAM
HYB 3117400BJ-50	on request	P-SOJ-26/24-1 300 mil	3.3 V 50 ns FPM-DRAM
HYB 3117400BJ-60	on request	P-SOJ-26/24-1 300 mil	3.3 V 60 ns FPM-DRAM
4k-Refresh Versions			
HYB 5116400BJ-50	Q67100-Q1049	P-SOJ-26/24-1 300 mil	5 V 50 ns FPM-DRAM
HYB 5116400BJ-60	Q67100-Q1050	P-SOJ-26/24-1 300 mil	5 V 60 ns FPM-DRAM
HYB 3116400BJ-50	on request	P-SOJ-26/24-1 300 mil	3.3 V 50 ns FPM-DRAM
HYB 3116400BJ-60	on request	P-SOJ-26/24-1 300 mil	3.3 V 60 ns FPM-DRAM
HYB 3116400BT-50	on request	P-TSOPII-26/24-1 300 mil	3.3 V 50 ns FPM-DRAM
HYB 3116400BT-60	on request	P-TSOPII-26/24-1 300 mil	3.3 V 60 ns FPM-DRAM

Pin Names

	HYB 5(3)116400 4k-Refresh	HYB 5(3)117400 2k-Refresh
Row Address Inputs	A0 - A11	A0 - A10
Column Address Inputs	A0 - A9	A0 - A10
Row Address Strobe		$\overline{\text{RAS}}$
Column Address Strobe		$\overline{\text{CAS}}$
Output Enable		$\overline{\text{OE}}$
Data Input/Output		I/O1 - I/O4
Read/Write Input		$\overline{\text{WE}}$
Power Supply		V_{CC}
Ground (0 V)		V_{SS}
Not Connected	—	N.C.

Pin Configuration

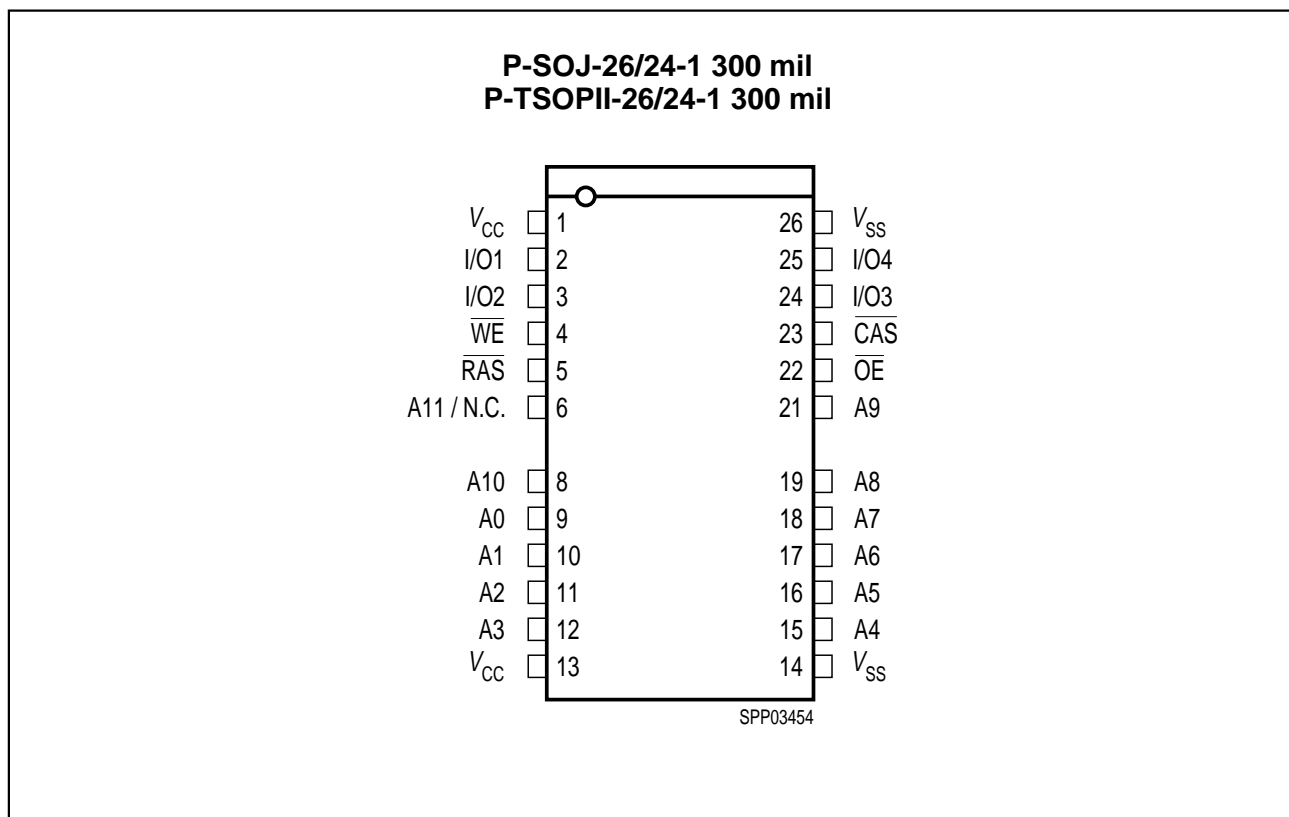

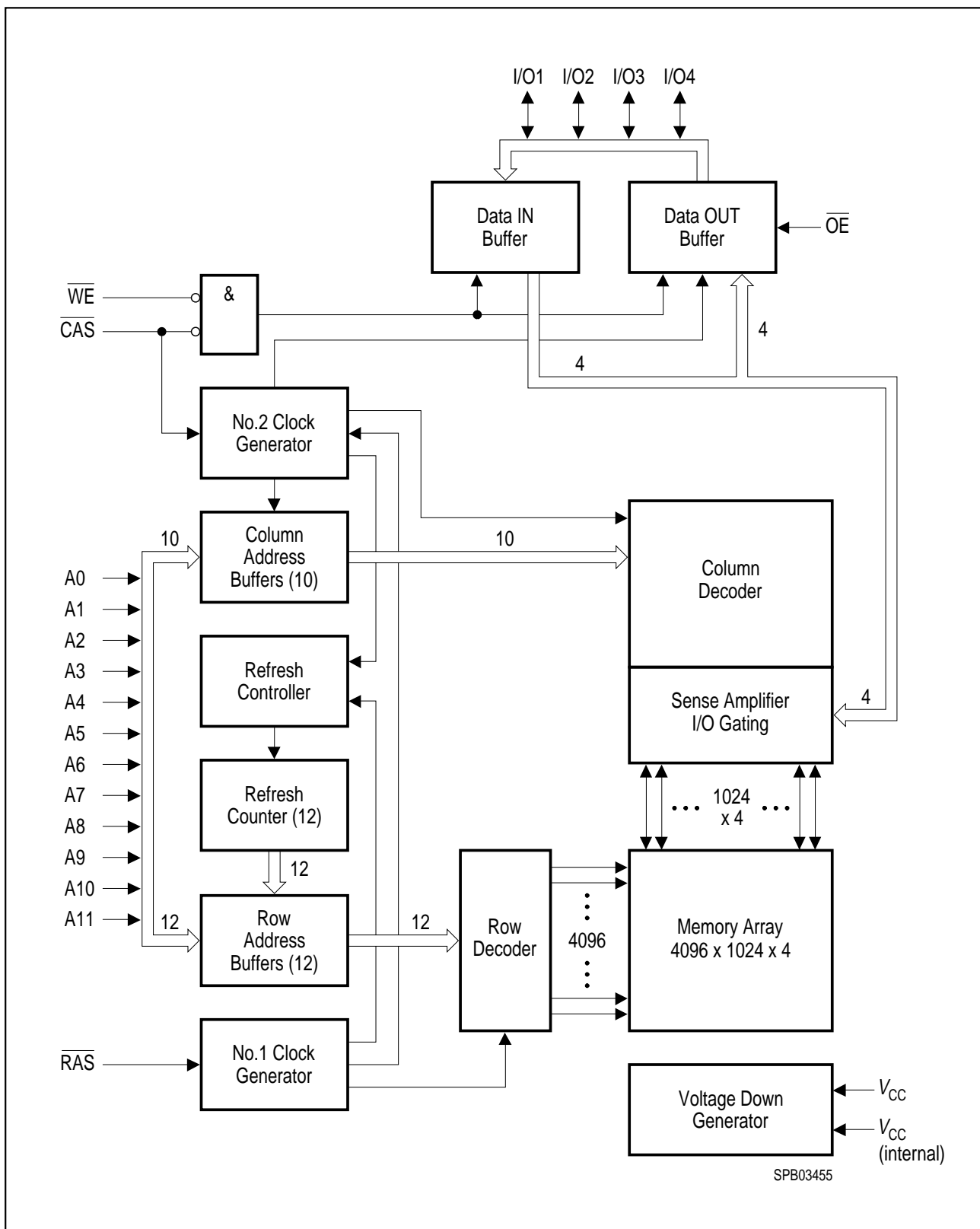

Block Diagram for HYB 5(3)116400 (4k-refresh)

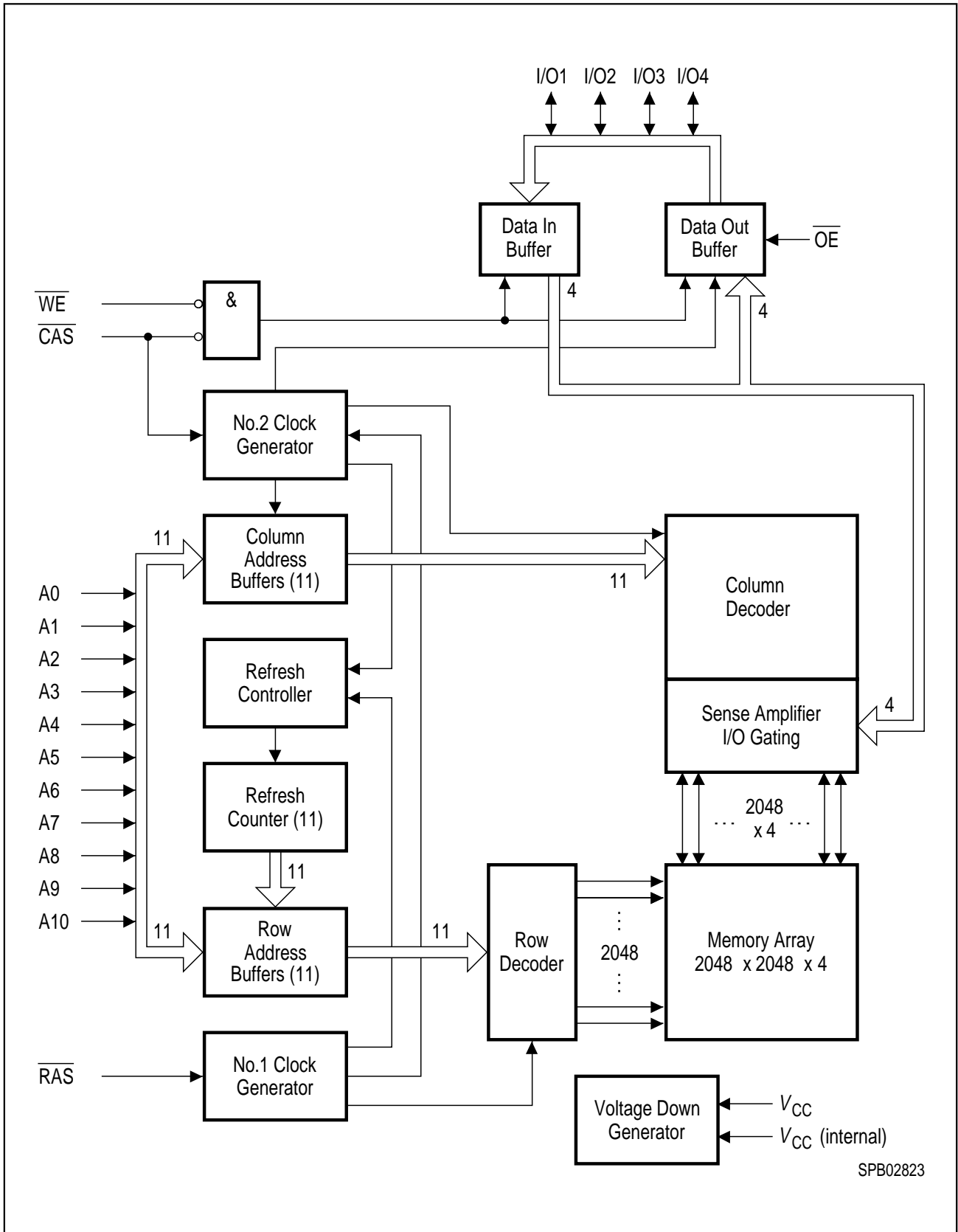

SPB02823

Block Diagram for HYB 5(3)117400 (2k-refresh)

Absolute Maximum Ratings

Operating temperature range	0 to 70 °C
Storage temperature range.....	– 55 to 150 °C
Input/output voltage (5 V versions)	– 0.5 to min ($V_{CC} + 0.5$, 7.0) V
Input/output voltage (3.3 V versions)	– 0.5 to min ($V_{CC} + 0.5$, 4.6) V
Power supply voltage (5 V versions)	– 1.0 V to 7.0 V
Power supply voltage (3.3 V versions)	– 1.0 V to 4.6 V
Power dissipation(5 V versions)	1.0 W
Power dissipation (3.3 V versions)	0.5 W
Data out current (short circuit)	50 mA

Note: Stresses above those listed under “Absolute Maximum Ratings” may cause permanent damage of the device. Exposure to absolute maximum rating conditions for extended periods may affect device reliability.

DC Characteristics

$T_A = 0$ to 70 °C, $V_{SS} = 0$ V, $t_T = 2$ ns

Parameter	Symbol	Limit Values		Unit	Test Condition
		min.	max.		
5 V Versions					
Power supply voltage	V_{CC}	4.5	5.5	V	
Input high voltage	V_{IH}	2.4	$V_{CC} + 0.5$	V	1
Input low voltage	V_{IL}	– 0.5	0.8	V	1
Output high voltage ($I_{OUT} = -5$ mA)	V_{OH}	2.4	–	V	1
Output low voltage ($I_{OUT} = 4.2$ mA)	V_{OL}	–	0.4	V	1
3.3 V Versions					
Power supply voltage	V_{CC}	3.0	3.6	V	
Input high voltage	V_{IH}	2.0	$V_{CC} + 0.5$	V	1
Input low voltage	V_{IL}	– 0.5	0.8	V	1
TTL Output high voltage ($I_{OUT} = -2$ mA)	V_{OH}	2.4	–	V	1
TTL Output low voltage ($I_{OUT} = 2$ mA)	V_{OL}	–	0.4	V	1
CMOS Output high voltage ($I_{OUT} = -100$ μA)	V_{OH}	$V_{CC} - 0.2$	–	V	
CMOS Output low voltage ($I_{OUT} = 100$ μA)	V_{OL}	–	0.2	V	

DC Characteristics (cont'd)

$T_A = 0$ to 70 °C, $V_{SS} = 0$ V, $t_T = 2$ ns

Parameter	Symbol	Limit Values		Unit	Notes	
		min.	max.			
			2k			4k
Common Parameters						
Input leakage current ($0 \text{ V} \leq V_{IH} \leq V_{CC} + 0.3 \text{ V}$, all other pins = 0 V)	$I_{I(L)}$	- 10	10	μA	1	
Output leakage current (DO is disabled, $0 \text{ V} \leq V_{OUT} \leq V_{CC} + 0.3 \text{ V}$)	$I_{O(L)}$	- 10	10	μA	1	
Average V_{CC} supply current -50 ns version -60 ns version ($\overline{\text{RAS}}$, $\overline{\text{CAS}}$, address cycling: $t_{RC} = t_{RC \text{ MIN.}}$)	I_{CC1}	-	80 70	50 40 mA mA	2, 3, 4 2, 3, 4	
Standby V_{CC} supply current ($\overline{\text{RAS}} = \overline{\text{CAS}} = V_{IH}$)	I_{CC2}	-	2	mA	-	
Average V_{CC} supply current, during $\overline{\text{RAS}}$ -only refresh cycles -50 ns version -60 ns version ($\overline{\text{RAS}}$ cycling, $\overline{\text{CAS}} = V_{IH}$, $t_{RC} = t_{RC \text{ MIN.}}$)	I_{CC3}	-	80 70	50 40 mA mA	2, 4 2, 4	
Average V_{CC} supply current, during fast page mode -50 ns version -60 ns version ($\overline{\text{RAS}} = V_{IL}$, $\overline{\text{CAS}}$, address cycling: $t_{PC} = t_{PC \text{ MIN.}}$)	I_{CC4}	-	25 20	mA mA	2, 3, 4 2, 3, 4	
Standby V_{CC} supply current ($\overline{\text{RAS}} = \overline{\text{CAS}} = V_{CC} - 0.2 \text{ V}$)	I_{CC5}	-	1	mA	1	
Average V_{CC} supply current, during $\overline{\text{CAS}}$ -before- $\overline{\text{RAS}}$ refresh mode -50 ns version -60 ns version ($\overline{\text{RAS}}$, $\overline{\text{CAS}}$ cycling: $t_{RC} = t_{RC \text{ MIN.}}$)	I_{CC6}	-	80 70	50 40 mA mA	2, 4 2, 4	

Capacitance

$T_A = 0$ to 70 °C, $f = 1$ MHz

Parameter	Symbol	Limit Values		Unit
		min.	max.	
Input capacitance (A0 to A11)	C_{I1}	–	5	pF
Input capacitance (\overline{RAS} , \overline{CAS} , \overline{WE} , \overline{OE})	C_{I2}	–	7	pF
I/O capacitance (I/O1 - I/O4)	C_{IO}	–	7	pF

AC Characteristics ^{5,6}

$T_A = 0$ to 70 °C, $V_{CC} = 5$ V \pm 10 % / $V_{CC} = 3.3$ V \pm 0.3 V, $t_T = 5$ ns

Parameter	Symbol	Limit Values				Unit	Note
		-50		-60			
		min.	max.	min.	max.		

Common Parameters

Random read or write cycle time	t_{RC}	90	–	110	–	ns	
\overline{RAS} precharge time	t_{RP}	30	–	40	–	ns	
\overline{RAS} pulse width	t_{RAS}	50	10k	60	10k	ns	
\overline{CAS} pulse width	t_{CAS}	13	10k	15	10k	ns	
Row address setup time	t_{ASR}	0	–	0	–	ns	
Row address hold time	t_{RAH}	8	–	10	–	ns	
Column address setup time	t_{ASC}	0	–	0	–	ns	
Column address hold time	t_{CAH}	10	–	15	–	ns	
\overline{RAS} to \overline{CAS} delay time	t_{RCD}	18	37	20	45		
\overline{RAS} to column address delay time	t_{RAD}	13	25	15	30	ns	
\overline{RAS} hold time	t_{RSH}	13		15	–	ns	
\overline{CAS} hold time	t_{CSH}	50		60	–	ns	
\overline{CAS} to \overline{RAS} precharge time	t_{CRP}	5	–	5	–	ns	
Transition time (rise and fall)	t_T	3	50	3	50	ns	⁷
Refresh period for 2k refresh version	t_{REF}	–	32	–	32	ms	
Refresh period for 4k refresh version	t_{REF}	–	64	–	64	ms	

Read Cycle

Access time from \overline{RAS}	t_{RAC}	–	50	–	60	ns	8, 9
Access time from \overline{CAS}	t_{CAC}	–	13	–	15	ns	8, 9
Access time from column address	t_{AA}	–	25	–	30	ns	8, 10

AC Characteristics (cont'd) ^{5, 6}

$T_A = 0$ to 70 °C, $V_{CC} = 5$ V \pm 10 % / $V_{CC} = 3.3$ V \pm 0.3 V, $t_T = 5$ ns

Parameter	Symbol	Limit Values				Unit	Note
		-50		-60			
		min.	max.	min.	max.		
\overline{OE} access time	t_{OEA}	–	13	–	15	ns	
Column address to \overline{RAS} lead time	t_{RAL}	25	–	30	–	ns	
Read command setup time	t_{RCS}	0	–	0	–	ns	
Read command hold time	t_{RCH}	0	–	0	–	ns	11
Read command hold time referenced to \overline{RAS}	t_{RRH}	0	–	0	–	ns	11
\overline{CAS} to output in low-Z	t_{CLZ}	0	–	0	–	ns	8
Output buffer turn-off delay	t_{OFF}	0	13	0	15	ns	12
Output buffer turn-off delay from \overline{OE}	t_{OEZ}	0	13	0	15	ns	12
Data to \overline{OE} low delay	t_{DZO}	0	–	0	–	ns	13
\overline{CAS} high to data delay	t_{CDD}	13	–	15	–	ns	14
\overline{OE} high to data delay	t_{ODD}	13	–	15	–	ns	14

Write Cycle

Write command hold time	t_{WCH}	8	–	10	–	ns	
Write command pulse width	t_{WCP}	8	–	10	–	ns	
Write command setup time	t_{WCS}	0	–	0	–	ns	15
Write command to \overline{RAS} lead time	t_{RWL}	13	–	15	–	ns	
Write command to \overline{CAS} lead time	t_{CWL}	13	–	15	–	ns	
Data setup time	t_{DS}	0	–	0	–	ns	16
Data hold time	t_{DH}	10	–	10	–	ns	16
Data to \overline{CAS} low delay	t_{DZC}	0	–	0	–	ns	13

Read-Modify-Write Cycle

Read-write cycle time	t_{RWC}	126	–	150	–	ns	
\overline{RAS} to \overline{WE} delay time	t_{RWD}	68	–	80	–	ns	15
\overline{CAS} to \overline{WE} delay time	t_{CWD}	31	–	35	–	ns	15
Column address to \overline{WE} delay time	t_{AWD}	43	–	50	–	ns	15
\overline{OE} command hold time	t_{OEH}	13	–	15	–	ns	

AC Characteristics (cont'd) ^{5, 6}

$T_A = 0$ to 70 °C, $V_{CC} = 5\text{ V} \pm 10\%$ / $V_{CC} = 3.3\text{ V} \pm 0.3\text{ V}$, $t_T = 5\text{ ns}$

Parameter	Symbol	Limit Values				Unit	Note
		-50		-60			
		min.	max.	min.	max.		

Fast Page Mode Cycle

Fast page mode cycle time	t_{PC}	35	–	40	–	ns	
$\overline{\text{CAS}}$ precharge time	t_{CP}	10	–	10	–	ns	
Access time from $\overline{\text{CAS}}$ precharge	t_{CPA}	–	30	–	35	ns	⁷
$\overline{\text{RAS}}$ pulse width	t_{RAS}	50	200k	60	200k	ns	
$\overline{\text{CAS}}$ precharge to $\overline{\text{RAS}}$ Delay	t_{RHPC}	30	–	35	–	ns	

Fast Page Mode Read-Modify-Write Cycle

Fast page mode read-write cycle time	t_{PRWC}	71	–	80	–	ns	
$\overline{\text{CAS}}$ precharge to $\overline{\text{WE}}$	t_{CPWD}	48	–	55	–	ns	

$\overline{\text{CAS}}$ -before- $\overline{\text{RAS}}$ Refresh Cycle

$\overline{\text{CAS}}$ setup time	t_{CSR}	10	–	10	–	ns	
$\overline{\text{CAS}}$ hold time	t_{CHR}	10	–	10	–	ns	
$\overline{\text{RAS}}$ to $\overline{\text{CAS}}$ precharge time	t_{RPC}	5	–	5	–	ns	
Write to $\overline{\text{RAS}}$ precharge time	t_{WRP}	10	–	10	–	ns	
Write hold time referenced to $\overline{\text{RAS}}$	t_{WRH}	10	–	10	–	ns	

$\overline{\text{CAS}}$ -before- $\overline{\text{RAS}}$ Counter Test Cycle

$\overline{\text{CAS}}$ precharge time	t_{CPT}	35	–	40	–	ns	
--	-----------	----	---	----	---	----	--

Test Mode

$\overline{\text{CAS}}$ hold time	t_{CHRT}	30	–	30	–	ns	
Write command setup time	t_{WTS}	10	–	10	–	ns	
Write command hold time	t_{WTH}	10	–	10	–	ns	
$\overline{\text{RAS}}$ hold time in test mode	t_{RAHT}	30	–	30	–	ns	

Notes

1. All voltages are referenced to V_{SS} .
2. I_{CC1} , I_{CC3} , I_{CC4} and I_{CC6} depend on cycle rate.
3. I_{CC1} and I_{CC4} depend on output loading. Specified values are measured with the output open.
4. Address can be changed once or less while $\overline{RAS} = V_{IL}$. In the case of I_{CC4} it can be changed once or less during a fast page mode cycle (t_{PC}).
5. An initial pause of 200 μs is required after power-up followed by 8 \overline{RAS} cycles of which at least one cycle has to be a refresh cycle, before proper device operation is achieved. In case of using internal refresh counter, a minimum of 8 \overline{CAS} -before- \overline{RAS} initialization cycles instead of 8 \overline{RAS} cycles are required.
6. AC measurements assume $t_T = 5$ ns.
7. $V_{IH(MIN.)}$ and $V_{IL(MAX.)}$ are reference levels for measuring timing of input signals. Transition times are also measured between V_{IH} and V_{IL} .
8. Measured with a load equivalent to 2 TTL loads and 100 pF.
9. Operation within the $t_{RCD(MAX.)}$ limit ensures that $t_{RAC(MAX.)}$ can be met. $t_{RCD(MAX.)}$ is specified as a reference point only: If t_{RCD} is greater than the specified $t_{RCD(MAX.)}$ limit, then access time is controlled by t_{CAC} .
10. Operation within the $t_{RAD(MAX.)}$ limit ensures that $t_{RAC(MAX.)}$ can be met. $t_{RAD(MAX.)}$ is specified as a reference point only: If t_{RAD} is greater than the specified $t_{RAD(MAX.)}$ limit, then access time is controlled by t_{AA} .
11. Either t_{RCH} or t_{RRH} must be satisfied for a read cycle.
12. $t_{OFF(MAX.)}$ and $t_{OEZ(MAX.)}$ define the time at which the outputs achieve the open-circuit condition and are not referenced to output voltage levels.
13. Either t_{DZC} or t_{DZO} must be satisfied.
14. Either t_{CDD} or t_{ODD} must be satisfied.
15. t_{WCS} , t_{RWD} , t_{CWD} , t_{AWD} and t_{CPWD} are not restrictive operating parameters. They are included in the data sheet as electrical characteristics only. If $t_{WCS} > t_{WCS(MIN.)}$, the cycle is an early write cycle and the I/O pin will remain open-circuit (high impedance) through the entire cycle; if $t_{RWD} > t_{RWD(MIN.)}$, $t_{CWD} > t_{CWD(MIN.)}$, $t_{AWD} > t_{AWD(MIN.)}$ and $t_{CPWD} > t_{CPWD(MIN.)}$, the cycle is a read-write cycle and I/O pins will contain data read from the selected cells. If neither of the above sets of conditions is satisfied, the condition of the I/O pins (at access time) is indeterminate.
16. These parameters are referenced to the \overline{CAS} leading edge in early write cycles and to the \overline{WE} leading edge in read-write cycles.

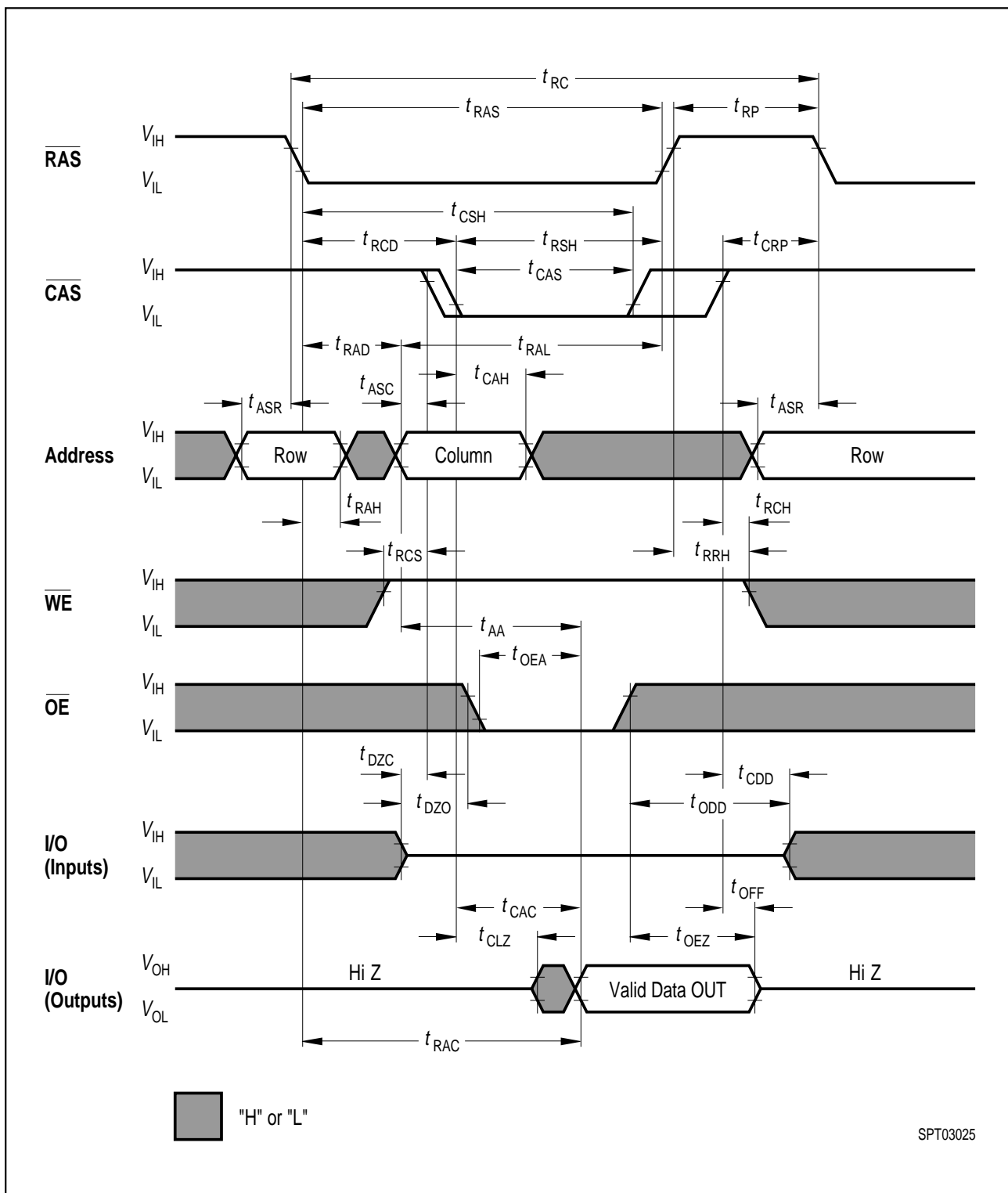

Read Cycle

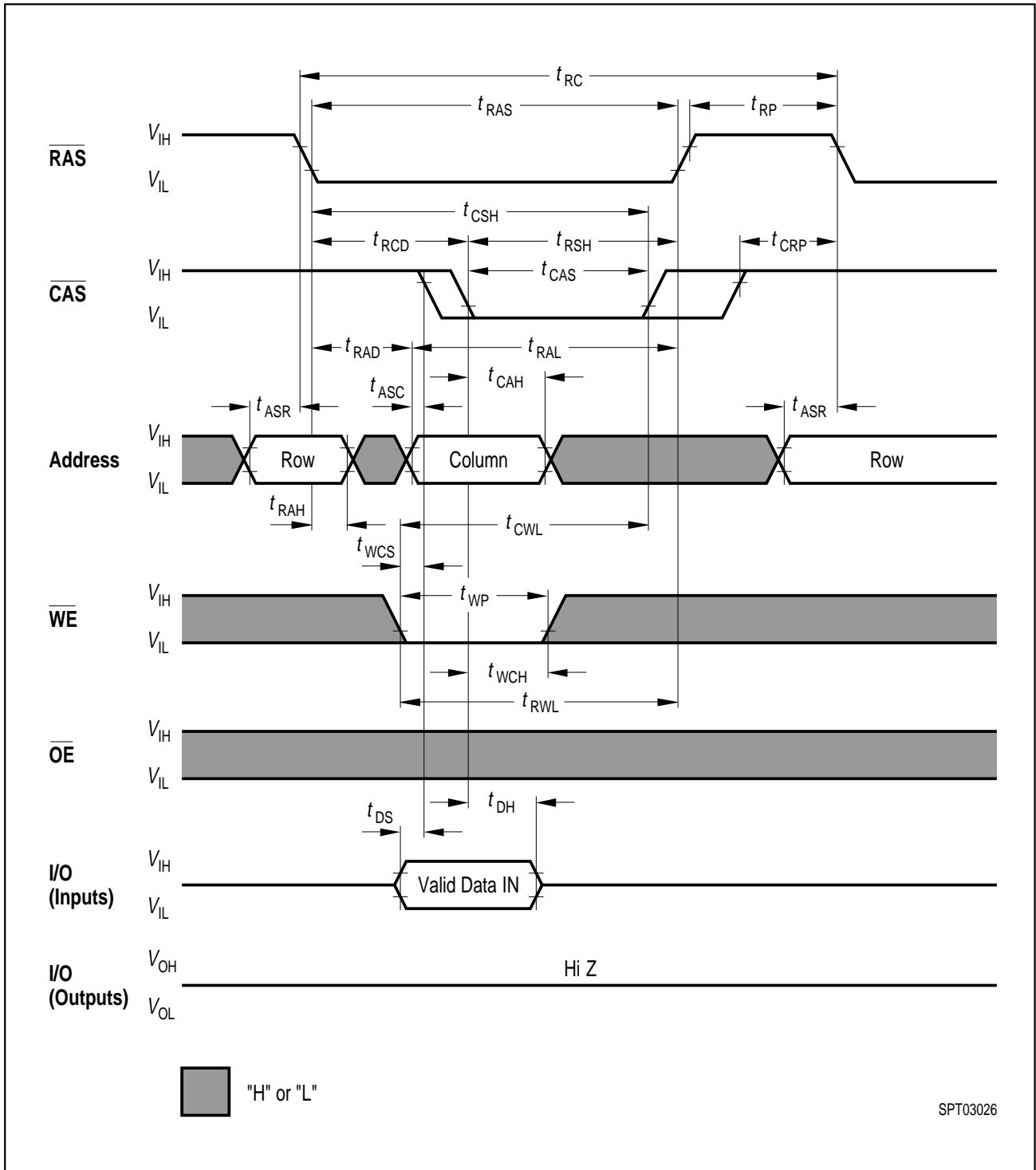

Write Cycle (Early Write)

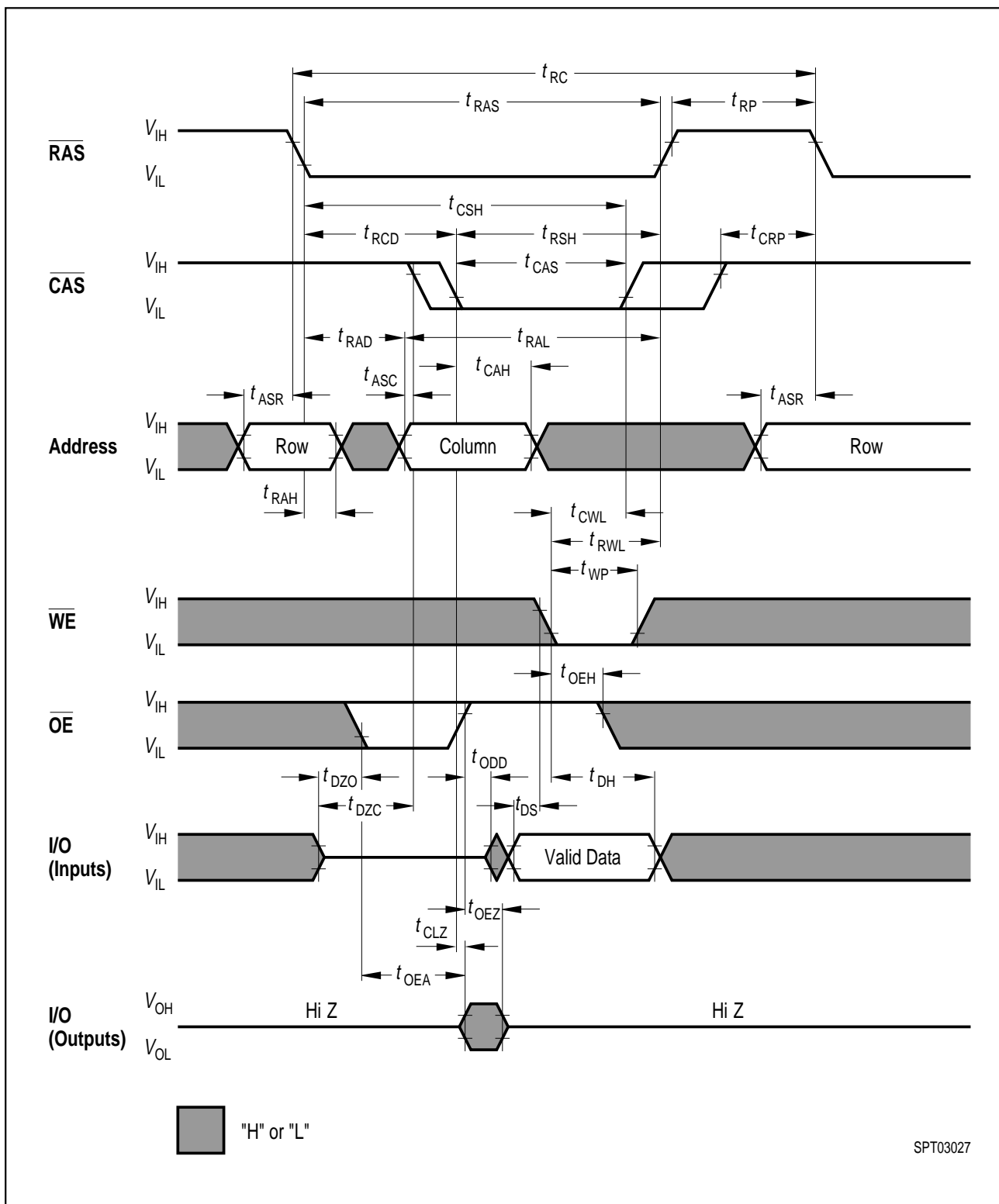

Write Cycle (\overline{OE} Controlled Write)

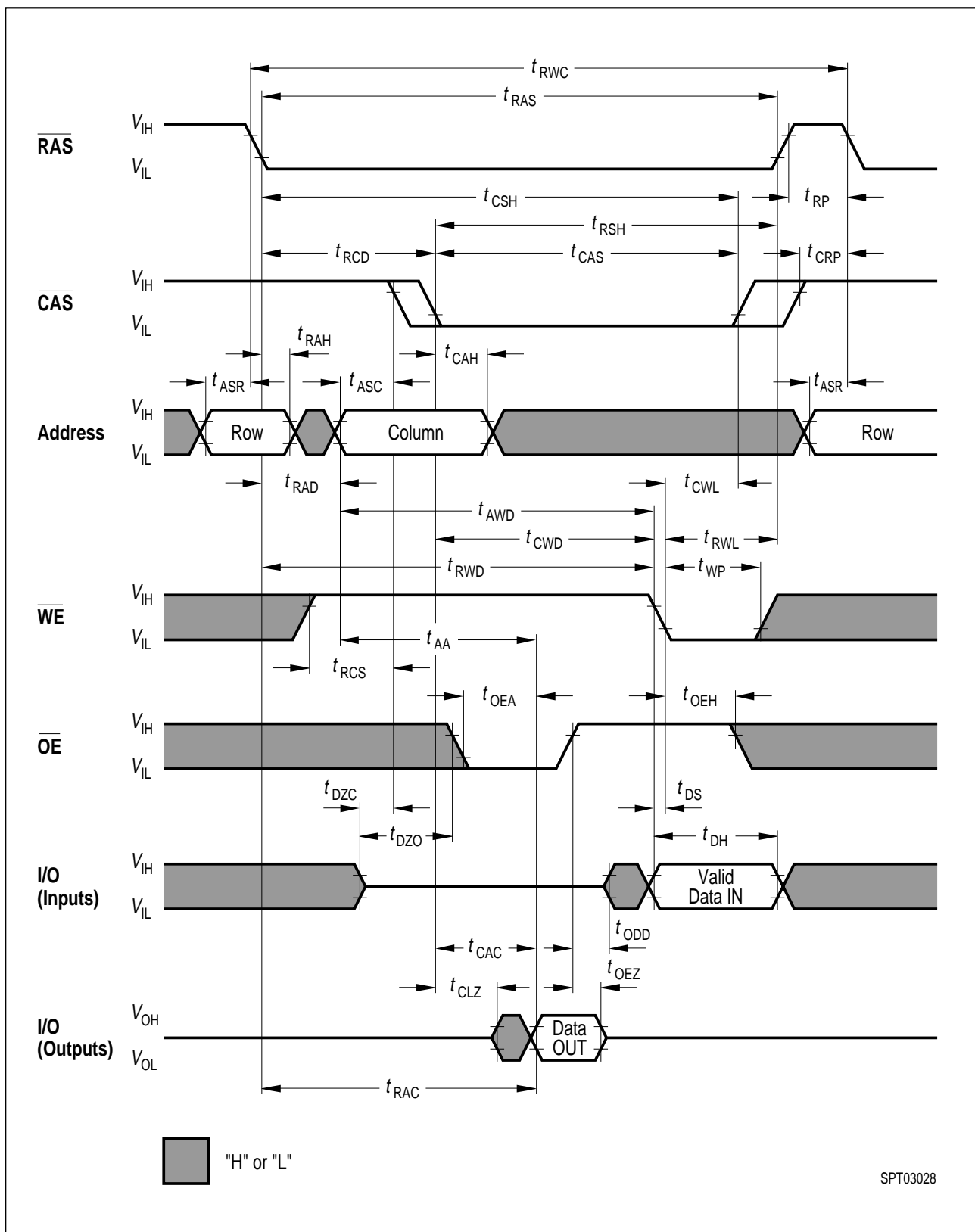

Read-Write (Read-Modify-Write) Cycle

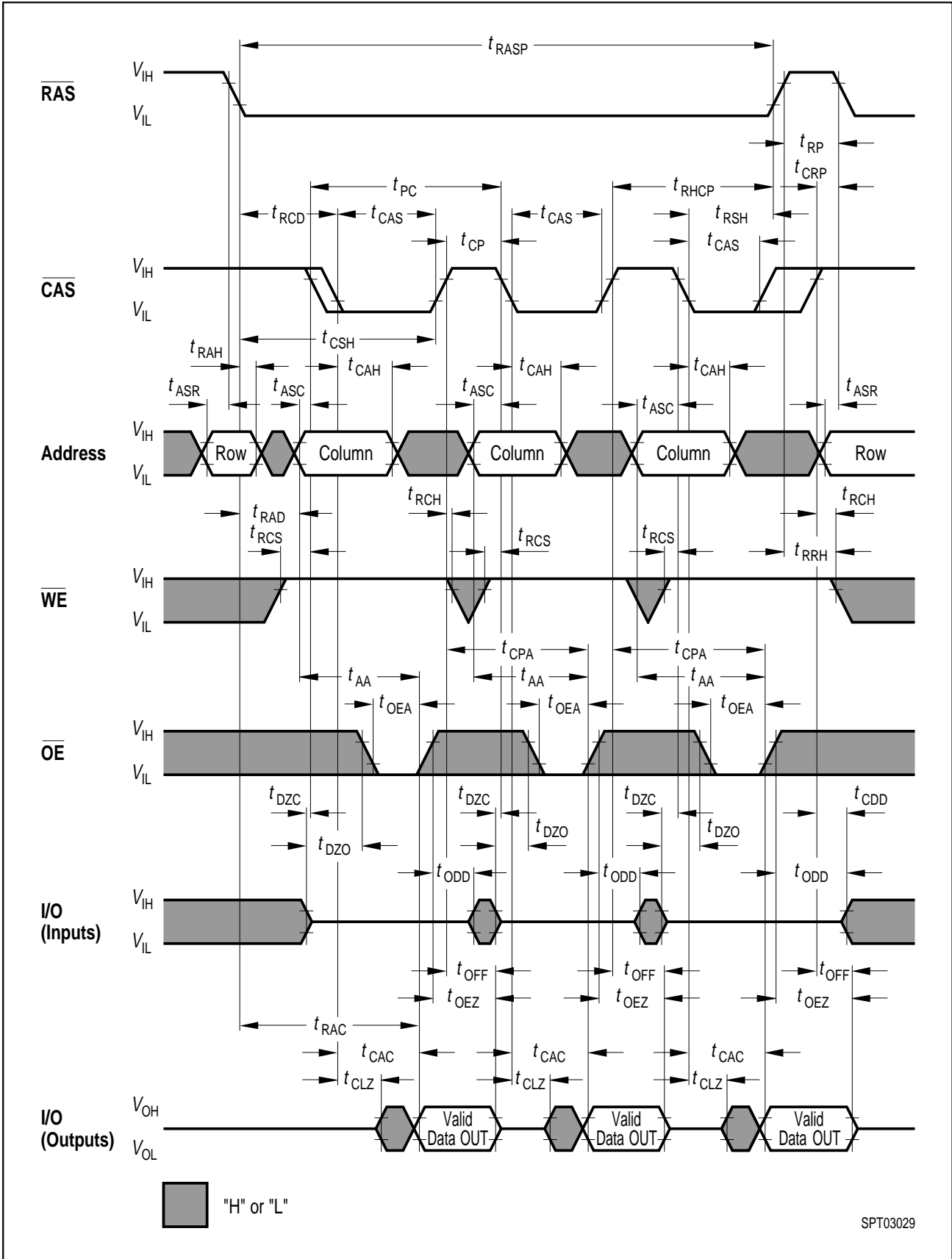

Fast Page Mode Read Cycle

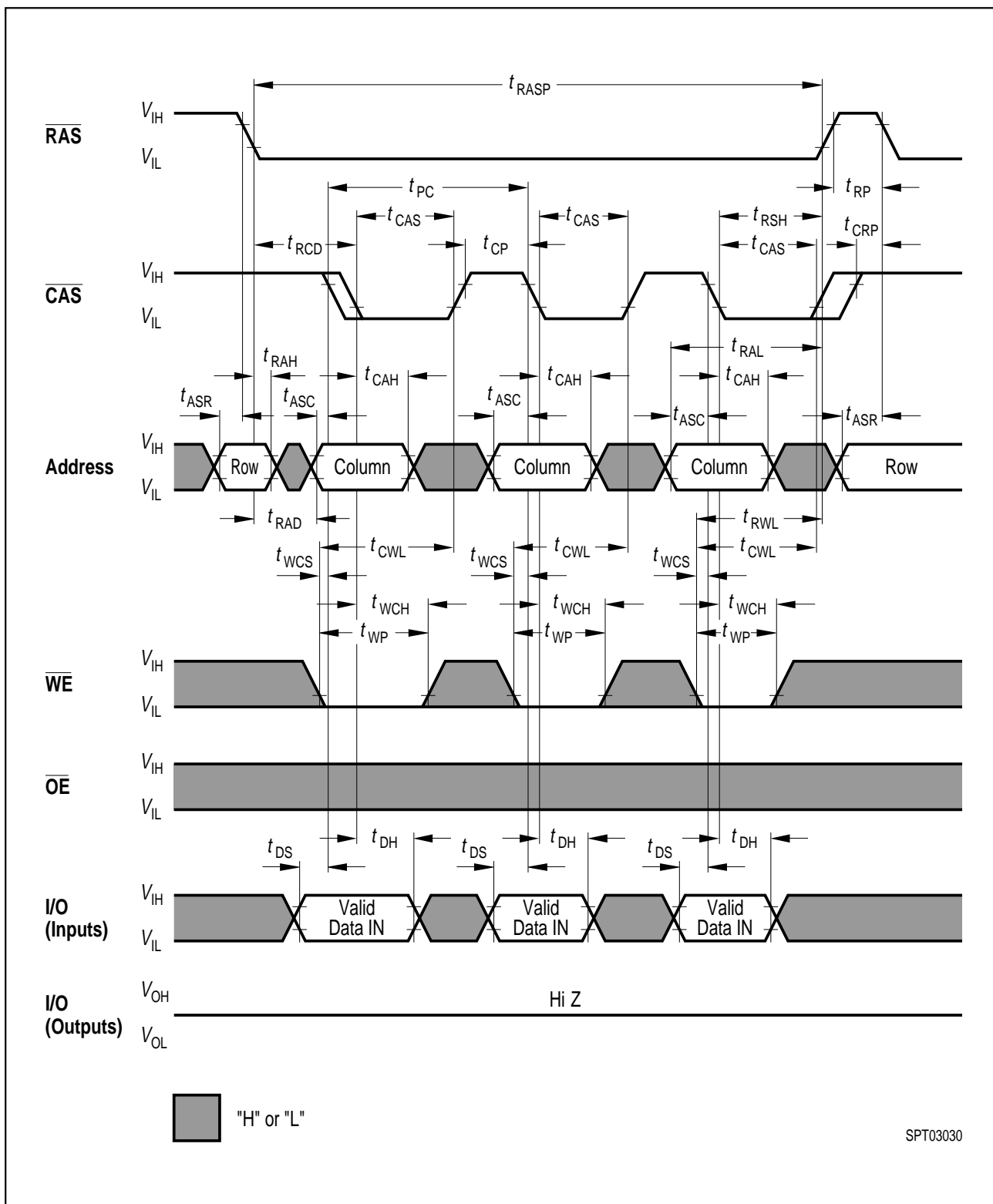

Fast Page Mode Early Write Cycle

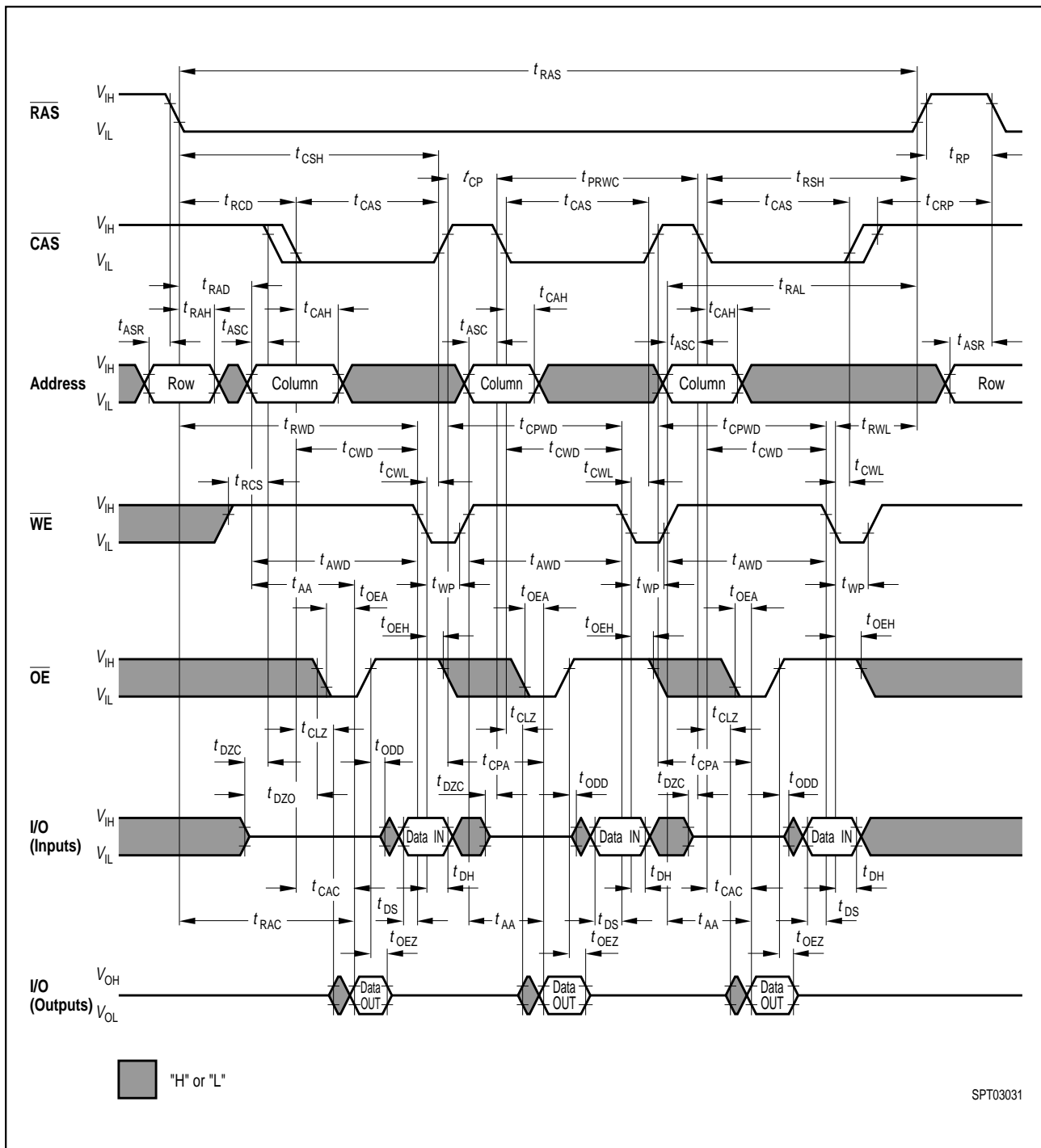

Fast Page Mode Late Write and Read-Modify Write Cycle

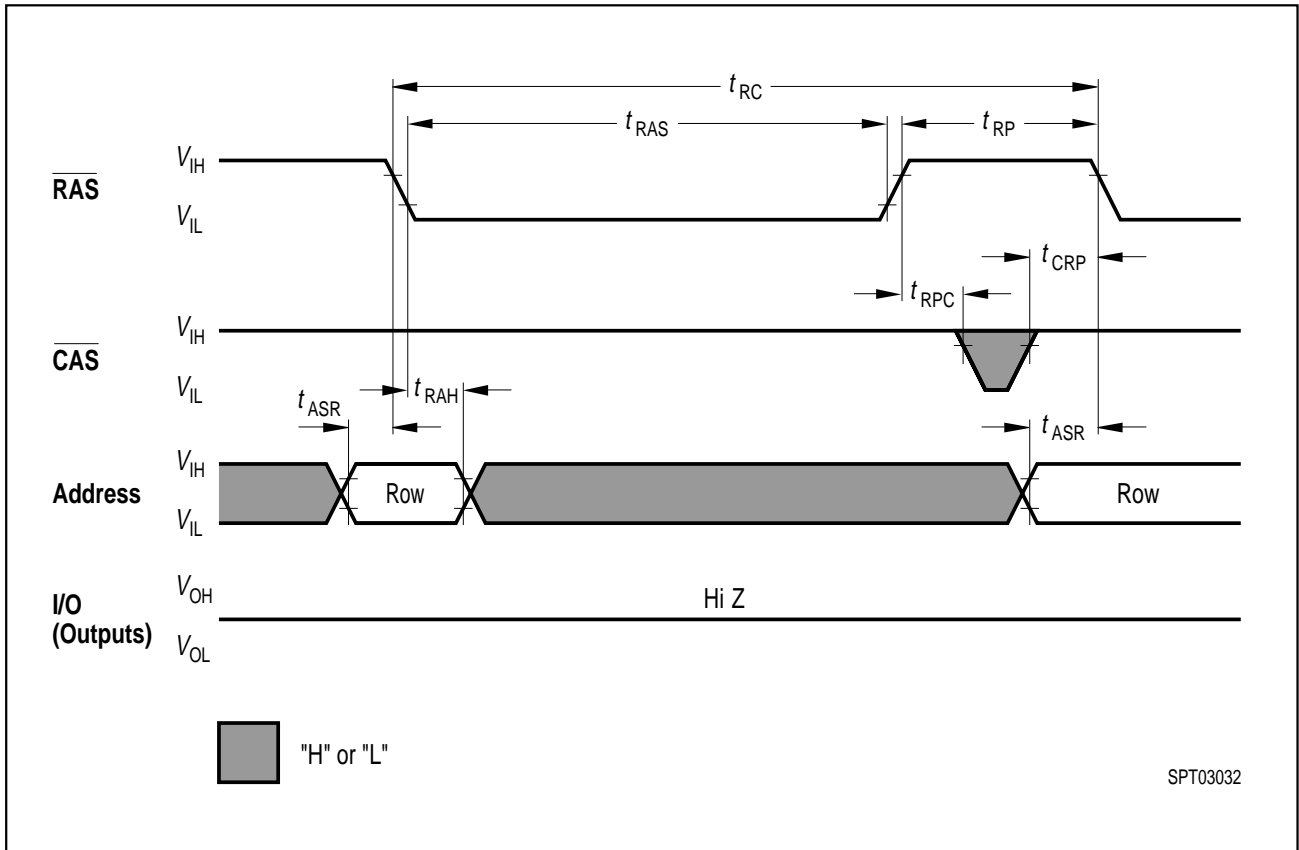

RAS-only Refresh Cycle

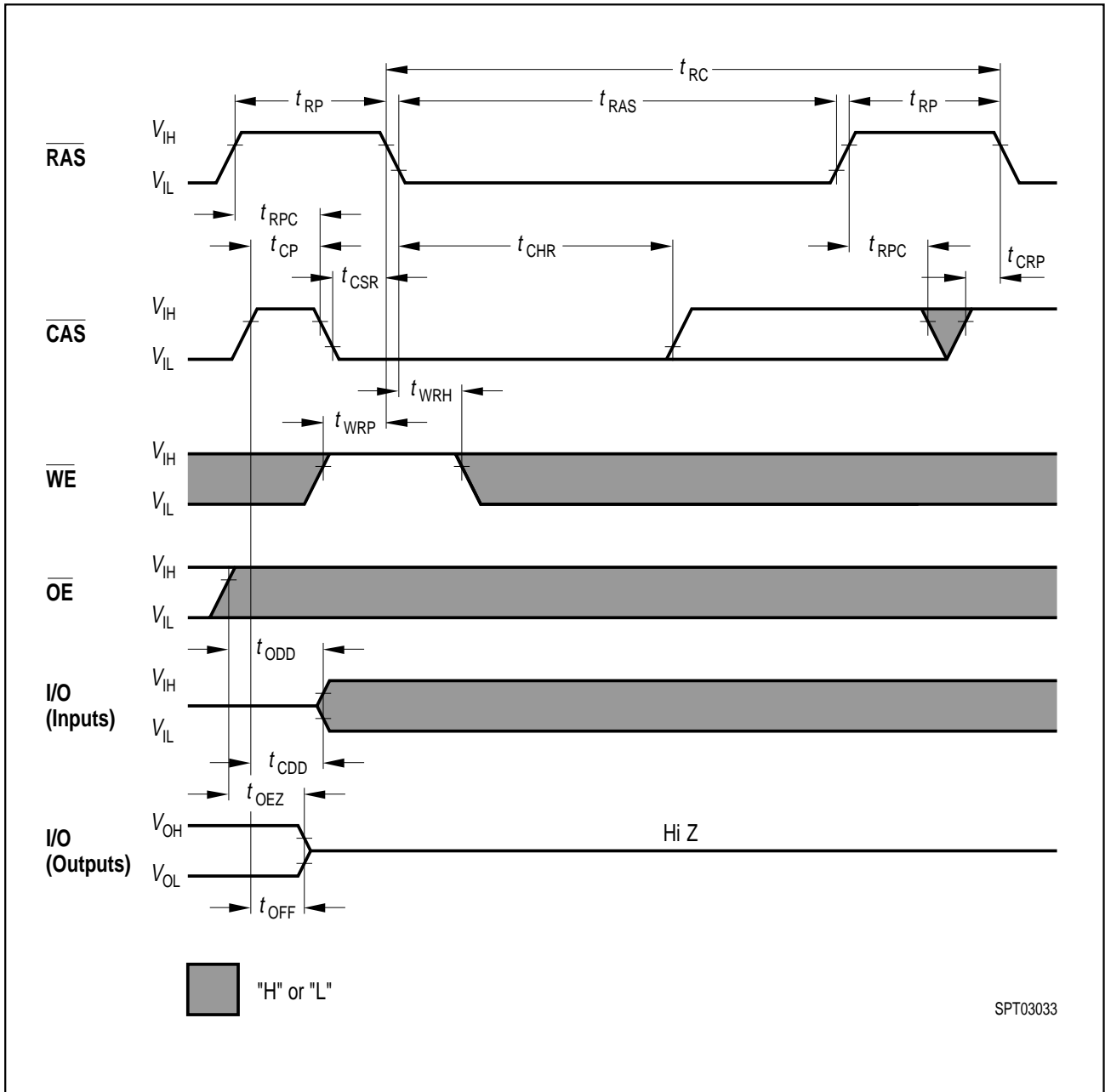

CAS-before-RAS Refresh Cycle

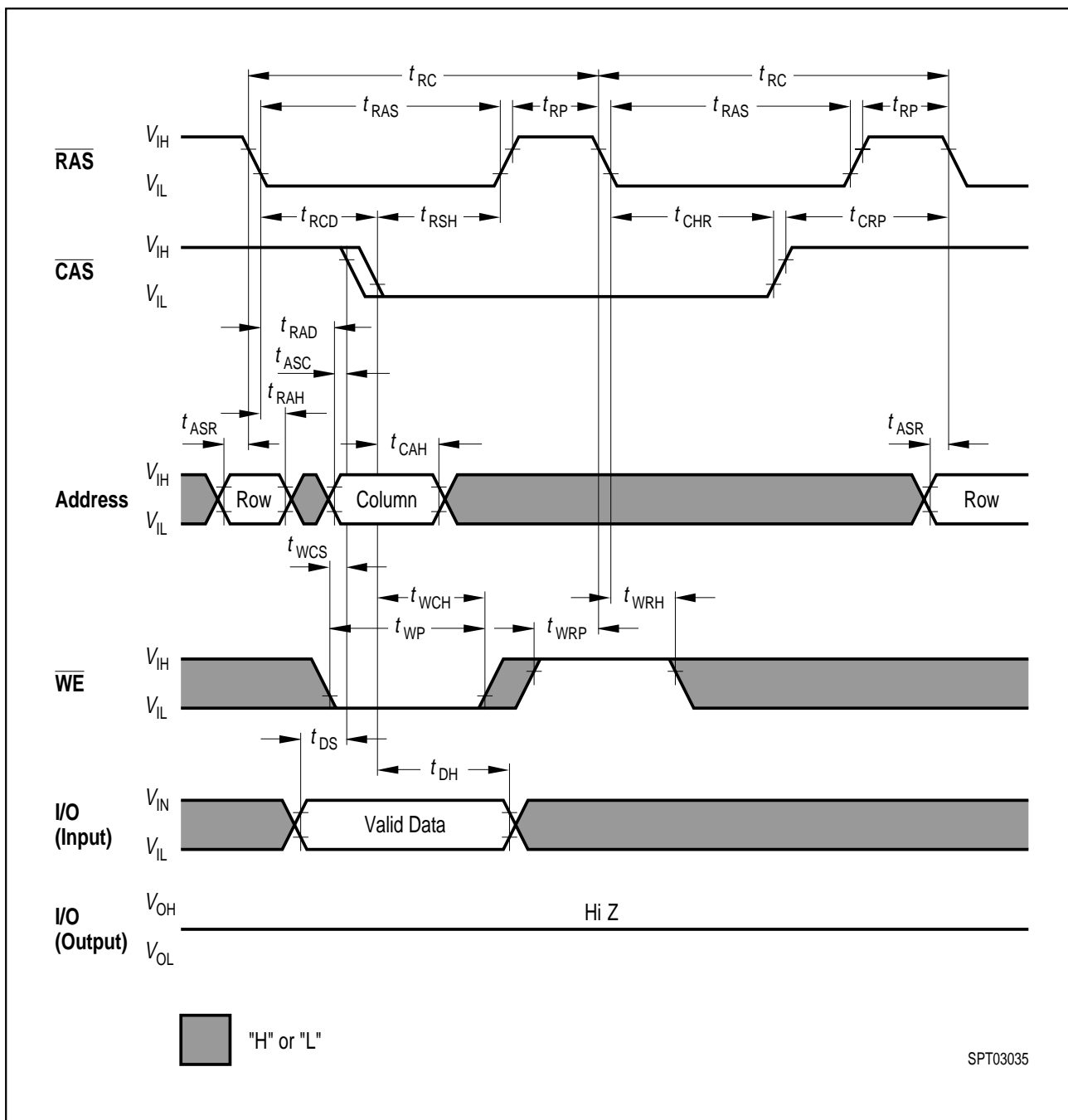

Hidden Refresh Early Write Cycle

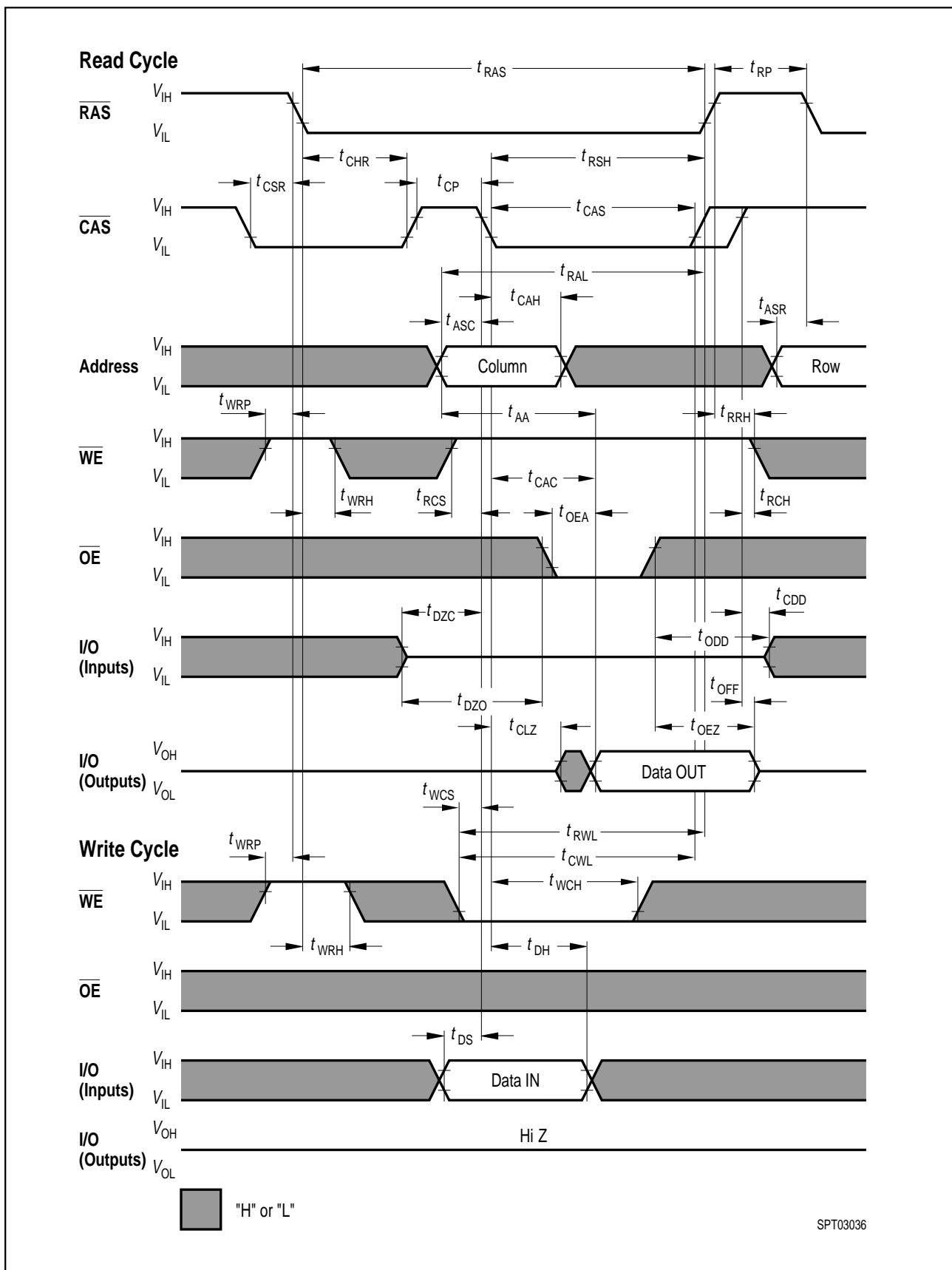

CAS-before-RAS Refresh Counter Test Cycle

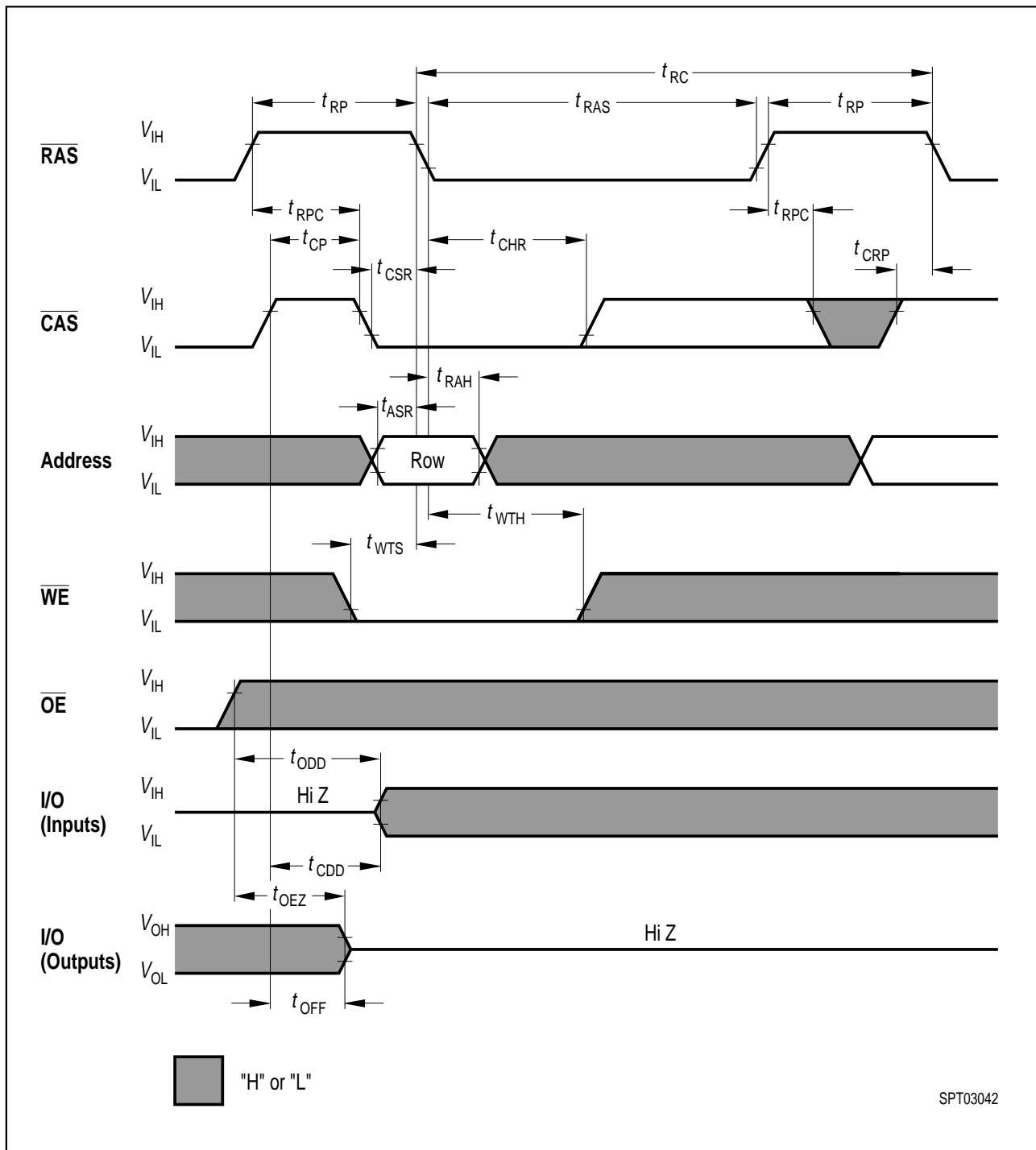

Test Mode Entry

Package Outlines

Plastic Package P-SOJ-26/24-1 (SMD) (300mil)
 (Plastic small outline J-leaded)

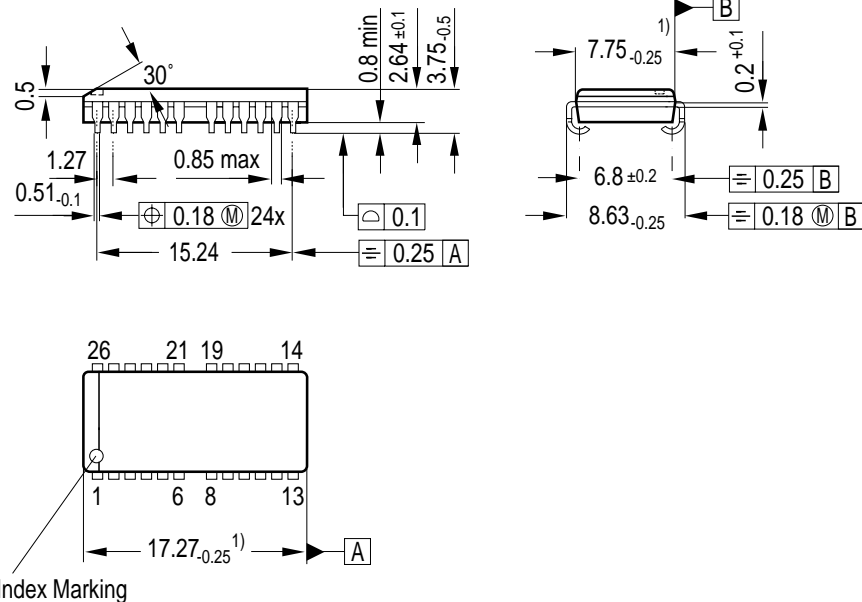

1) Does not include plastic or metal protrusions of 0.15 max per side

GPJ05628

Sorts of Packing

Package outlines for tubes, trays etc. are contained in our Data Book "Package Information".

SMD = Surface Mounted Device

Dimensions in mm

Plastic Package P-TSOPII-26/24-1 (400 mil) (SMD)
 (Plastic Thin Small Outline Package (Type II))

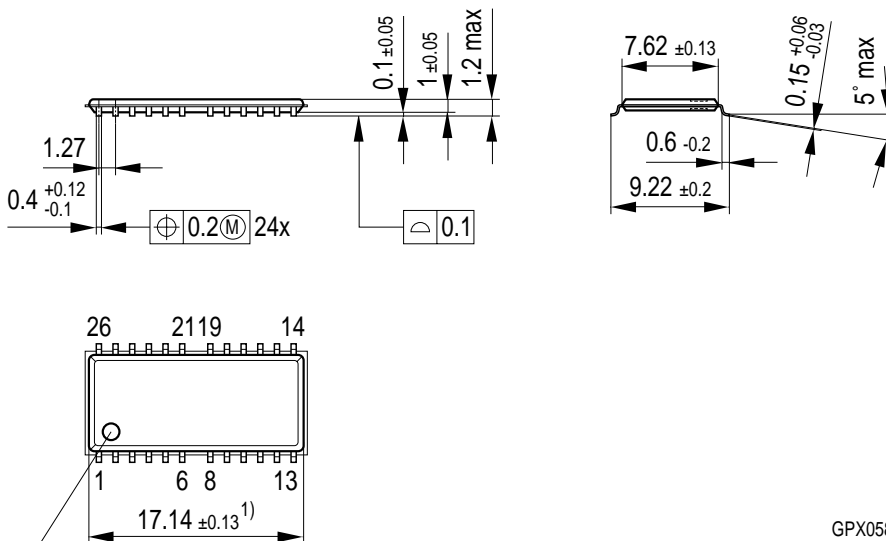

Index Marking

¹⁾ Does not include plastic or metal protrusion of 0.15 max per side

Sorts of Packing

Package outlines for tubes, trays etc. are contained in our Data Book "Package Information".

SMD = Surface Mounted Device

Dimensions in mm



LittleDiode supplies new, hard to find or obsolete electronic components and semiconductors all over the world.

With over two million different components listed you are sure to find the part you need.

Feel free to visit us today at our online store:

LittleDiode.com

Looking forward to providing you with the best possible service.