

**1M × 16-Bit Dynamic RAM
1k Refresh
(Hyper Page Mode-EDO)**

**HYB 5118165BSJ/BST-50/-60
HYB 3118165BSJ/BST-50/-60**

Advanced Information

- 1 048 576 words by 16-bit organization
- 0 to 70 °C operating temperature
- Hyper Page Mode-EDO-operation
- Performance:

		-50	-60	
t_{RAC}	\overline{RAS} access time	50	60	ns
t_{CAC}	\overline{CAS} access time	13	15	ns
t_{AA}	Access time from address	25	30	ns
t_{RC}	Read/Write cycle time	84	104	ns
t_{HPC}	Hyper page mode (EDO) cycle time	20	25	ns

- Power Dissipation, Refresh & Addressing:

	HYB5118165		HYB3118165		
	-50	-60	-50	-60	
Power Supply	5 V ± 10 %		3.3 V ± 0.3 V		
Addressing	10/10		10/10		
Refresh	1024 cycles / 16 ms				
Active	715	632	468	414	mW
TTL Standby	11		7.2		mW
CMOS Standby	5.5		3.6		mW

- Read, write, read-modify-write, \overline{CAS} -before- \overline{RAS} refresh, \overline{RAS} -only refresh and hidden refresh
- All inputs, outputs and clocks fully TTL (5 V versions) and LV-TTL (3.3 V version)-compatible
- Plastic Package: P-SOJ-42-1 400 mil
P-TSOPII-50/44-1 400 mil

The HYB 5(3)118165 are 16 MBit dynamic RAMs based on die revisions "G" & "F" and organized as 1 048 576 words by 16-bits. The HYB 5(3)118165 utilizes a submicron CMOS silicon gate process technology, as well as advanced circuit techniques to provide wide operating margins, both internally and for the system user. Multiplexed address inputs permit the HYB 5(3)18165 to be packaged in a standard SOJ-42 and TSOPII-50/44 plastic package with 400 mil width. These packages provide high system bit densities and are compatible with commonly used automatic testing and insertion equipment.

Ordering Information

Type	Ordering Code	Package	Descriptions
HYB 5118165BSJ-50	Q67100-Q1107	P-SOJ-42-1 400 mil	5 V 50 ns EDO-DRAM
HYB 5118165BSJ-60	Q67100-Q1108	P-SOJ-42-1 400 mil	5 V 60 ns EDO-DRAM
HYB 3118165BSJ-50	on request	P-SOJ-42-1 400 mil	3.3 V 50 ns EDO-DRAM
HYB 3118165BSJ-60	on request	P-SOJ-42-1 400 mil	3.3 V 60 ns EDO-DRAM
HYB 5118165BST-50	on request	P-TSOPII-50/44-1 400 mil	5 V 50 ns EDO-DRAM
HYB 5118165BST-60	on request	P-TSOPII-50/44-1 400 mil	5 V 60 ns EDO-DRAM
HYB 3118165BST-50	on request	P-TSOPII-50/44-1 400 mil	3.3 V 50 ns EDO-DRAM
HYB 3118165BST-60	on request	P-TSOPII-50/44-1 400 mil	3.3 V 60 ns EDO-DRAM

Pin Names and Configuration

	HYB 5(3)118165
Row Address Inputs	A0 - A9
Column Address Inputs	A0 - A9
Row Address Strobe	$\overline{\text{RAS}}$
Upper Column Address Strobe	UCAS
Lower Column Address Strobe	LCAS
Output Enable	$\overline{\text{OE}}$
Data Input/Output	I/O1 - I/O16
Read/Write Input	$\overline{\text{WE}}$
Power Supply	V_{CC}
Ground (0 V)	V_{SS}
Not Connected	N.C.

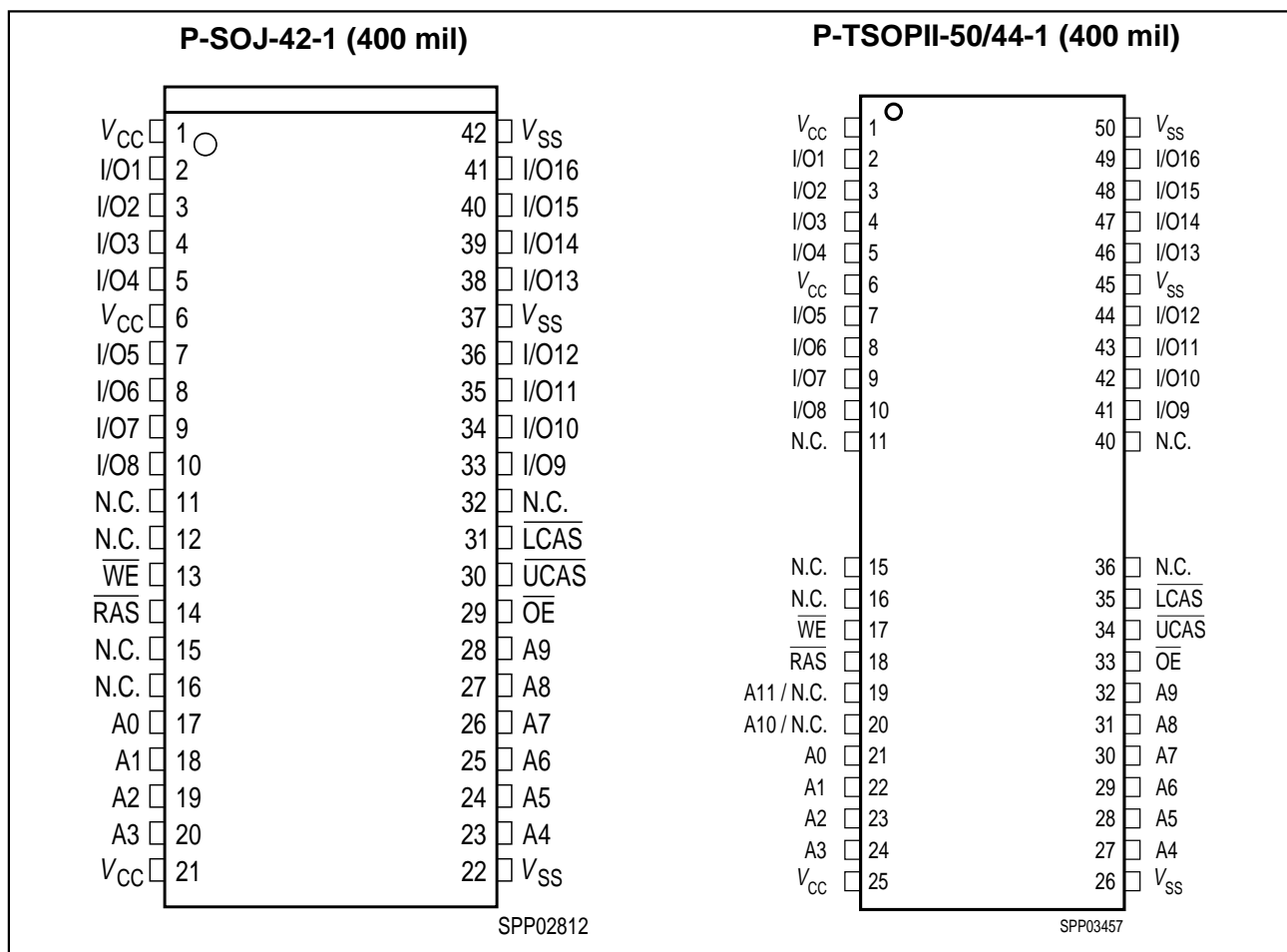

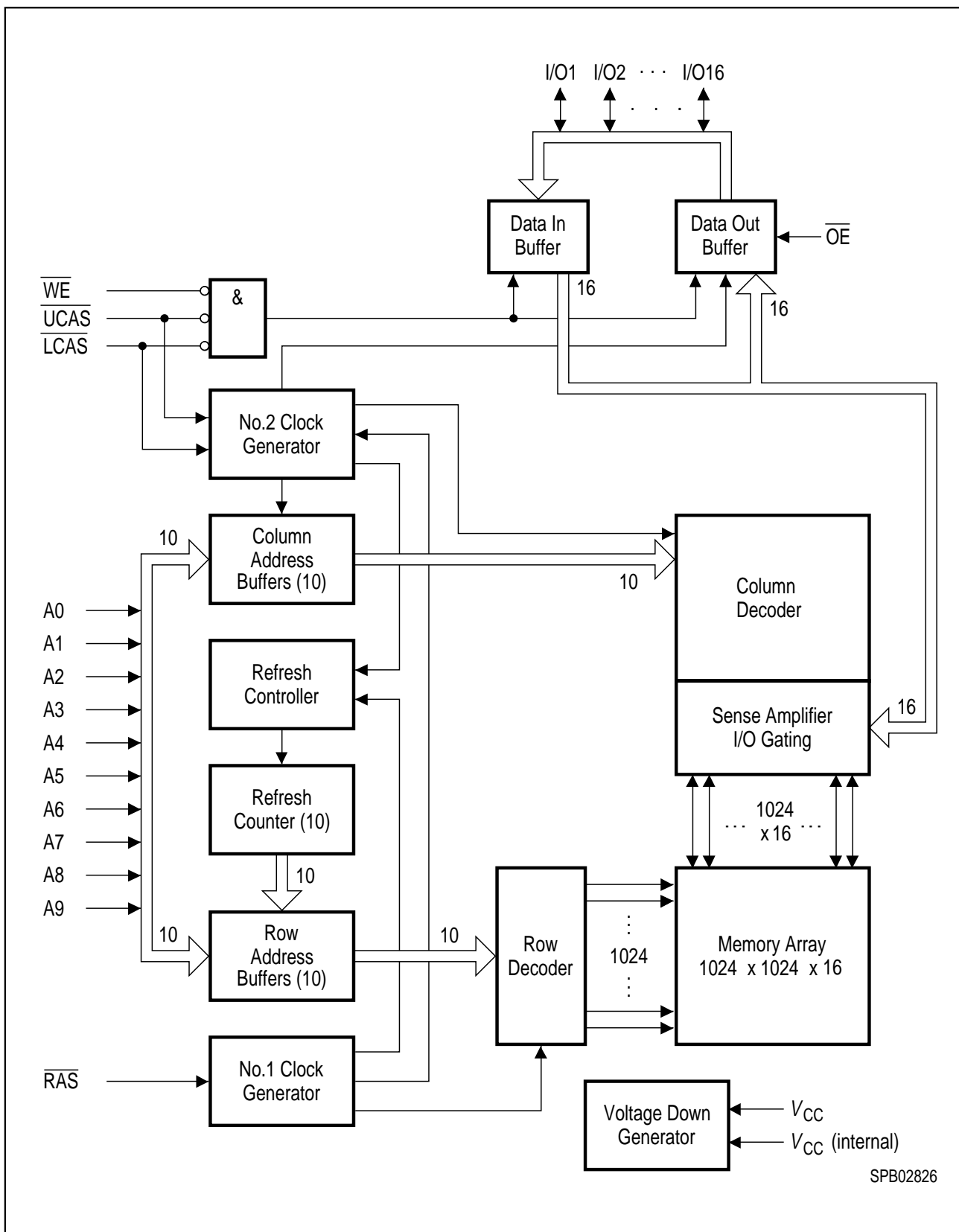

SPB02826

Block Diagram for HYB 5118165BSJ

Absolute Maximum Ratings

Operating temperature range	0 to 70 °C
Storage temperature range.....	– 55 to 150 °C
Input/output voltage (5 V versions)	– 0.5 to min ($V_{CC} + 0.5$, 7.0) V
Input/output voltage (3.3 V versions)	– 0.5 to min ($V_{CC} + 0.5$, 4.6) V
Power supply voltage (5 V versions)	– 1.0 V to 7.0 V
Power supply voltage (3.3 V versions)	– 1.0 V to 4.6 V
Power dissipation (5 V versions)	1.0 W
Power dissipation (3.3 V versions)	0.5 W
Data out current (short circuit)	50 mA

Note: Stresses above those listed under “Absolute Maximum Ratings” may cause permanent damage of the device. Exposure to absolute maximum rating conditions for extended periods may affect device reliability.

DC Characteristics

$T_A = 0$ to 70 °C, $V_{SS} = 0$ V, $t_T = 2$ ns

Parameter	Symbol	Limit Values		Unit	Test Condition
		min.	max.		

5 V Versions

Power supply voltage	V_{CC}	4.5	5.5	V	
Input high voltage	V_{IH}	2.4	$V_{CC} + 0.5$	V	1
Input low voltage	V_{IL}	– 0.5	0.8	V	1
Output high voltage ($I_{OUT} = -5$ mA)	V_{OH}	2.4	–	V	1
Output low voltage ($I_{OUT} = 4.2$ mA)	V_{OL}	–	0.4	V	1

3.3 V Versions

Power supply voltage	V_{CC}	3.0	3.6	V	
Input high voltage	V_{IH}	2.0	$V_{CC} + 0.5$	V	1
Input low voltage	V_{IL}	– 0.5	0.8	V	1
TTL Output high voltage ($I_{OUT} = -2$ mA)	V_{OH}	2.4	–	V	1
TTL Output low voltage ($I_{OUT} = 2$ mA)	V_{OL}	–	0.4	V	1
CMOS Output high voltage ($I_{OUT} = -100$ μA)	V_{OH}	$V_{CC} - 0.2$	–	V	
CMOS Output low voltage ($I_{OUT} = 100$ μA)	V_{OL}	–	0.2	V	

DC Characteristics (cont'd)

$T_A = 0$ to 70 °C, $V_{SS} = 0$ V, $t_T = 2$ ns

Parameter	Symbol	Limit Values		Unit	Notes
		min.	max.		
Common Parameters					
Input leakage current ($0 \text{ V} \leq V_{IH} \leq V_{CC} + 0.3 \text{ V}$, all other pins = 0 V)	$I_{I(L)}$	- 10	10	μA	1
Output leakage current (DO is disabled, $0 \text{ V} \leq V_{OUT} \leq V_{CC} + 0.3 \text{ V}$)	$I_{O(L)}$	- 10	10	μA	1
Average V_{CC} supply current -50 ns version -60 ns version ($\overline{\text{RAS}}$, $\overline{\text{CAS}}$, address cycling: $t_{RC} = t_{RC \text{ MIN.}}$)	I_{CC1}	-	130 115	mA mA	2, 3, 4 2, 3, 4
Standby V_{CC} supply current ($\overline{\text{RAS}} = \overline{\text{CAS}} = V_{IH}$)	I_{CC2}	-	2	mA	-
Average V_{CC} supply current, during $\overline{\text{RAS}}$ -only refresh cycles -50 ns version -60 ns version ($\overline{\text{RAS}}$ cycling, $\overline{\text{CAS}} = V_{IH}$, $t_{RC} = t_{RC \text{ MIN.}}$)	I_{CC3}	-	130 115	mA mA	2, 4 2, 4
Average V_{CC} supply current, during hyper page mode (EDO) -50 ns version -60 ns version ($\overline{\text{RAS}} = V_{IL}$, $\overline{\text{CAS}}$, address cycling: $t_{PC} = t_{PC \text{ MIN.}}$)	I_{CC4}	-	50 40	mA mA	2, 3, 4 2, 3, 4
Standby V_{CC} supply current ($\overline{\text{RAS}} = \overline{\text{CAS}} = V_{CC} - 0.2 \text{ V}$)	I_{CC5}	-	1	mA	1
Average V_{CC} supply current, during $\overline{\text{CAS}}$ -before- $\overline{\text{RAS}}$ refresh mode -50 ns version -60 ns version ($\overline{\text{RAS}}$, $\overline{\text{CAS}}$ cycling: $t_{RC} = t_{RC \text{ MIN.}}$)	I_{CC6}	-	130 115	mA mA	2, 4 2, 4

Capacitance

$T_A = 0$ to 70 °C, $f = 1$ MHz

Parameter	Symbol	Limit Values		Unit
		min.	max.	
Input capacitance (A0 to A11)	C_{I1}	–	5	pF
Input capacitance (\overline{RAS} , \overline{UCAS} , \overline{LCAS} , \overline{WE} , \overline{OE})	C_{I2}	–	7	pF
I/O capacitance (I/O1 - I/O16)	C_{IO}	–	7	pF

AC Characteristics ^{5,6}

$T_A = 0$ to 70 °C, $V_{CC} = 5$ V \pm 10 % / $V_{CC} = 3.3$ V \pm 0.3 V, $t_T = 2$ ns

Parameter	Symbol	Limit Values				Unit	Note
		-50		-60			
		min.	max.	min.	max.		

Common Parameters

Random read or write cycle time	t_{RC}	84	–	104	–	ns	
\overline{RAS} precharge time	t_{RP}	30	–	40	–	ns	
\overline{RAS} pulse width	t_{RAS}	50	10k	60	10k	ns	
\overline{CAS} pulse width	t_{CAS}	8	10k	10	10k	ns	
Row address setup time	t_{ASR}	0	–	0	–	ns	
Row address hold time	t_{RAH}	8	–	10	–	ns	
Column address setup time	t_{ASC}	0	–	0	–	ns	
Column address hold time	t_{CAH}	8	–	10	–	ns	
\overline{RAS} to \overline{CAS} delay time	t_{RCD}	12	37	14	45	ns	
\overline{RAS} to column address delay	t_{RAD}	10	25	12	30	ns	
\overline{RAS} hold time	t_{RSH}	13	–	15	–	ns	
\overline{CAS} hold time	t_{CSH}	40	–	50	–	ns	
\overline{CAS} to \overline{RAS} precharge time	t_{CRP}	5	–	5	–	ns	
Transition time (rise and fall)	t_T	1	50	1	50	ns	⁷
Refresh period for 1k-refresh version	t_{REF}	–	16	–	16	ms	

Read Cycle

Access time from \overline{RAS}	t_{RAC}	–	50	–	60	ns	^{8,9}
Access time from \overline{CAS}	t_{CAC}	–	13	–	15	ns	^{8,9}
Access time from column address	t_{AA}	–	25	–	30	ns	^{8,10}
\overline{OE} access time	t_{OEA}	–	13	–	15	ns	

AC Characteristics (cont'd) ^{5, 6}

$T_A = 0$ to 70 °C, $V_{CC} = 5$ V \pm 10 % / $V_{CC} = 3.3$ V \pm 0.3 V, $t_T = 2$ ns

Parameter	Symbol	Limit Values				Unit	Note
		-50		-60			
		min.	max.	min.	max.		
Column address to \overline{RAS} lead time	t_{RAL}	25	–	30	–	ns	
Read command setup time	t_{RCS}	0	–	0	–	ns	
Read command hold time	t_{RCH}	0	–	0	–	ns	11
Read command hold time referenced to \overline{RAS}	t_{RRH}	0	–	0	–	ns	11
\overline{CAS} to output in low-Z	t_{CLZ}	0	–	0	–	ns	8
Output buffer turn-off delay	t_{OFF}	0	13	0	15	ns	12
Output turn-off delay from \overline{OE}	t_{OEZ}	0	13	0	15	ns	12
Data to \overline{CAS} low delay	t_{DZC}	0	–	0	–	ns	13
Data to \overline{OE} low delay	t_{DZO}	0	–	0	–	ns	13
\overline{CAS} high to data delay	t_{CDD}	10	–	13	–	ns	14
\overline{OE} high to data delay	t_{ODD}	10	–	13	–	ns	14

Write Cycle

Write command hold time	t_{WCH}	8	–	10	–	ns	
Write command pulse width	t_{WCP}	8	–	10	–	ns	
Write command setup time	t_{WCS}	0	–	0	–	ns	15
Write command to \overline{RAS} lead time	t_{RWL}	8	–	10	–	ns	
Write command to \overline{CAS} lead time	t_{CWL}	8	–	10	–	ns	
Data setup time	t_{DS}	0	–	0	–	ns	16
Data hold time	t_{DH}	8	–	10	–	ns	16

Read-Modify-Write Cycle

Read-write cycle time	t_{RWC}	113	–	138	–	ns	
\overline{RAS} to \overline{WE} delay time	t_{RWD}	64	–	77	–	ns	15
\overline{CAS} to \overline{WE} delay time	t_{CWD}	27	–	32	–	ns	15
Column address to \overline{WE} delay time	t_{AWD}	39	–	47	–	ns	15
\overline{OE} command hold time	t_{OEH}	10	–	13	–	ns	

Hyper Page Mode (EDO) Cycle

Hyper page mode (EDO) cycle time	t_{HPC}	20	–	25	–	ns	
\overline{CAS} precharge time	t_{CP}	8	–	10	–	ns	

AC Characteristics (cont'd) ^{5, 6}

$T_A = 0$ to 70 °C, $V_{CC} = 5\text{ V} \pm 10\%$ / $V_{CC} = 3.3\text{ V} \pm 0.3\text{ V}$, $t_T = 2\text{ ns}$

Parameter	Symbol	Limit Values				Unit	Note
		-50		-60			
		min.	max.	min.	max.		
Access time from $\overline{\text{CAS}}$ precharge	t_{CPA}	–	27	–	32	ns	⁷
Output data hold time	t_{COH}	5	–	5	–	ns	
$\overline{\text{RAS}}$ pulse width in EDO mode	t_{RAS}	50	200k	60	200k	ns	
$\overline{\text{CAS}}$ precharge to $\overline{\text{RAS}}$ delay	t_{RHCP}	27	–	32	–	ns	
$\overline{\text{OE}}$ setup time prior to $\overline{\text{CAS}}$	t_{OES}	5	–	5	–	5	–

Hyper Page Mode (EDO) Read-Modify-Write Cycle

Hyper page mode (EDO) read-write cycle time	t_{PRWC}	58	–	68	–	ns	
$\overline{\text{CAS}}$ precharge to $\overline{\text{WE}}$	t_{CPWD}	41	–	49	–	ns	

$\overline{\text{CAS}}$ -before- $\overline{\text{RAS}}$ Refresh Cycle

$\overline{\text{CAS}}$ setup time	t_{CSR}	10	–	10	–	ns	
$\overline{\text{CAS}}$ hold time	t_{CHR}	10	–	10	–	ns	
$\overline{\text{RAS}}$ to $\overline{\text{CAS}}$ precharge time	t_{RPC}	5	–	5	–	ns	
Write to $\overline{\text{RAS}}$ precharge time	t_{WRP}	10	–	10	–	ns	
Write hold time referenced to $\overline{\text{RAS}}$	t_{WRH}	10	–	10	–	ns	

$\overline{\text{CAS}}$ -before- $\overline{\text{RAS}}$ Counter Test Cycle

$\overline{\text{CAS}}$ precharge time ($\overline{\text{CAS}}$ -before- $\overline{\text{RAS}}$ counter test cycle)	t_{CPT}	35	–	40	–	ns	
---	------------------	----	---	----	---	----	--

Notes

1. All voltages are referenced to V_{SS} .
2. I_{CC1} , I_{CC3} , I_{CC4} and I_{CC6} depend on cycle rate.
3. I_{CC1} and I_{CC4} depend on output loading. Specified values are obtained with the output open.
4. Address can be changed once or less while $RAS = V_{IL}$. In case of I_{CC4} it can be changed once or less during a hyper page mode (EDO) cycle
5. An initial pause of 200 μs is required after power-up followed by 8 \overline{RAS} cycles of which at least one cycle has to be a refresh cycle, before proper device operation is achieved. In case of using the internal refresh counter, a minimum of 8 \overline{CAS} -before- \overline{RAS} initialization cycles instead of 8 \overline{RAS} cycles are required.
6. AC measurements assume $t_T = 2$ ns.
7. $V_{IH(MIN.)}$ and $V_{IL(MAX.)}$ are reference levels for measuring timing of input signals. Transition times are also measured between V_{IH} and V_{IL} .
8. Measured with the specified current load and 100 pF at $V_{OL} = 0.8$ V and $V_{OH} = 2.0$ V. Access time is determined by the latter of t_{RAC} , t_{CAC} , t_{AA} , t_{CPA} , t_{OEA} . t_{CAC} is measured from tristate.
9. Operation within the $t_{RCD(MAX.)}$ limit ensures that $t_{RAC(MAX.)}$ can be met. $t_{RCD(MAX.)}$ is specified as a reference point only. If t_{RCD} is greater than the specified $t_{RCD(MAX.)}$ limit, then access time is controlled by t_{CAC} .
10. Operation within the $t_{RAD(MAX.)}$ limit ensures that $t_{RAC(MAX.)}$ can be met. $t_{RAD(MAX.)}$ is specified as a reference point only. If t_{RAD} is greater than the specified $t_{RAD(MAX.)}$ limit, then access time is controlled by t_{AA} .
11. Either t_{RCH} or t_{RRH} must be satisfied for a read cycle.
12. $t_{OFF(MAX.)}$, $t_{OEZ(MAX.)}$ define the time at which the output achieves the open-circuit conditions and are not referenced to output voltage levels. t_{OFF} is referenced from the rising edge of \overline{RAS} or \overline{CAS} , whichever occurs last.
13. Either t_{DZC} or t_{DZO} must be satisfied.
14. Either t_{CDD} or t_{ODD} must be satisfied.
15. t_{WCS} , t_{RWD} , t_{CWD} and t_{AWD} are not restrictive operating parameters. They are included in the data sheet as electrical characteristics only. If $t_{WCS} > t_{WCS(MIN.)}$, the cycle is an early write cycle and data out pin will remain open-circuit (high impedance) through the entire cycle; if $t_{RWD} > t_{RWD(MIN.)}$, $t_{CWD} > t_{CWD(MIN.)}$ and $t_{AWD} > t_{AWD(MIN.)}$, the cycle is a read-write cycle and I/O will contain data read from the selected cells. If neither of the above sets of conditions is satisfied, the condition of I/O (at access time) is indeterminate.
16. These parameters are referenced to the \overline{CAS} leading edge in early write cycles and to the \overline{WE} leading edge in read-write cycles.

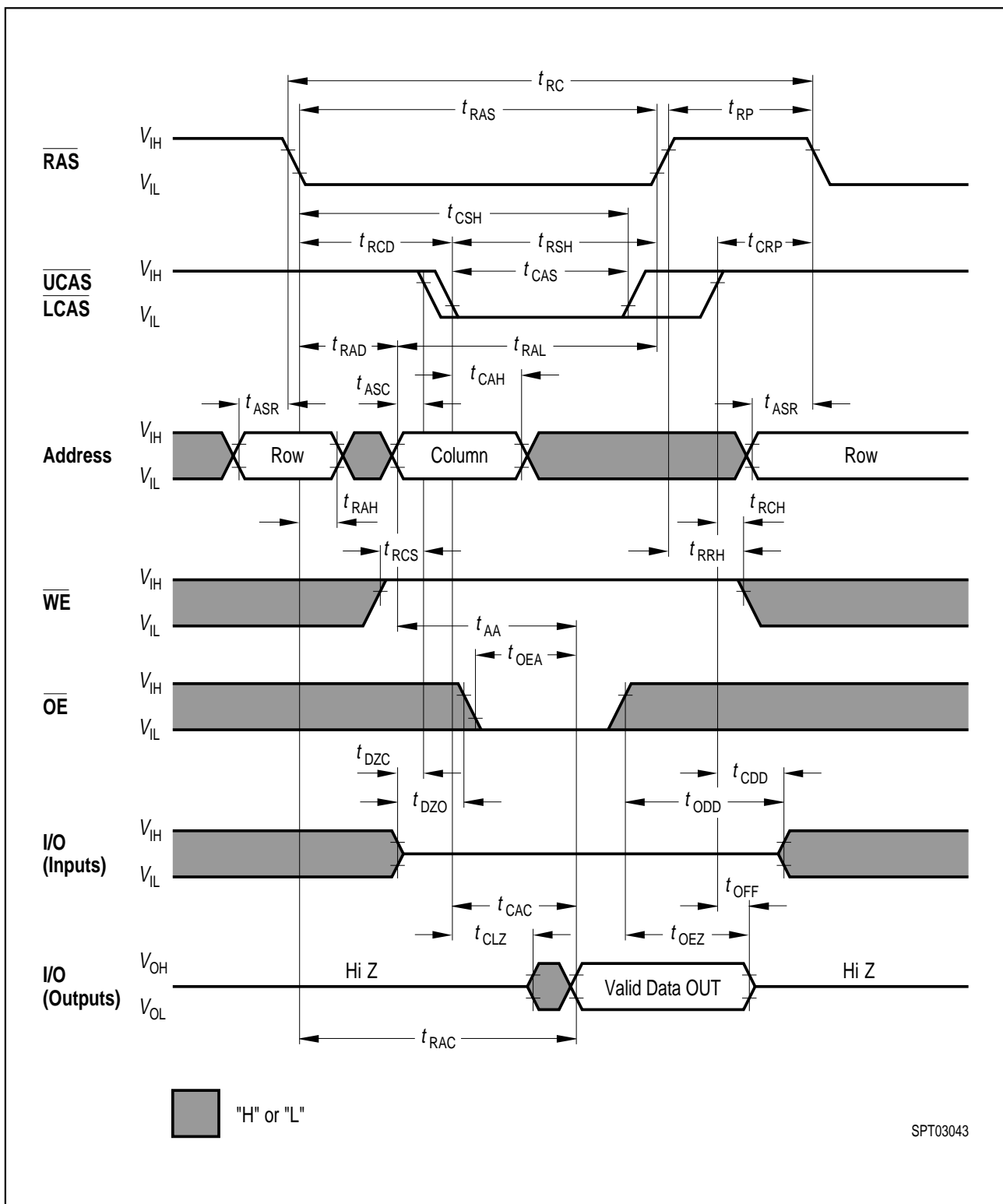

Read Cycle

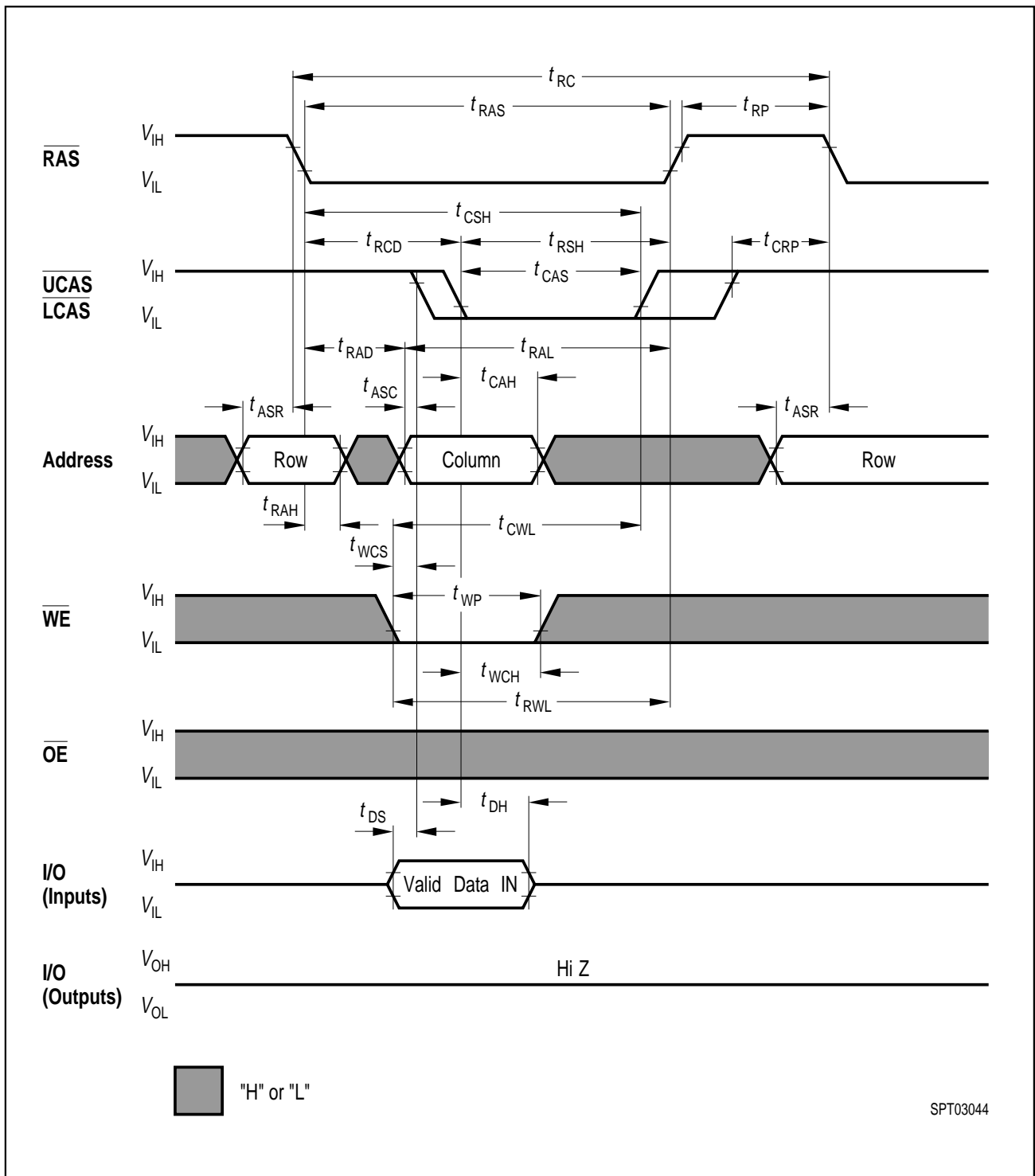

Write Cycle (Early Write)

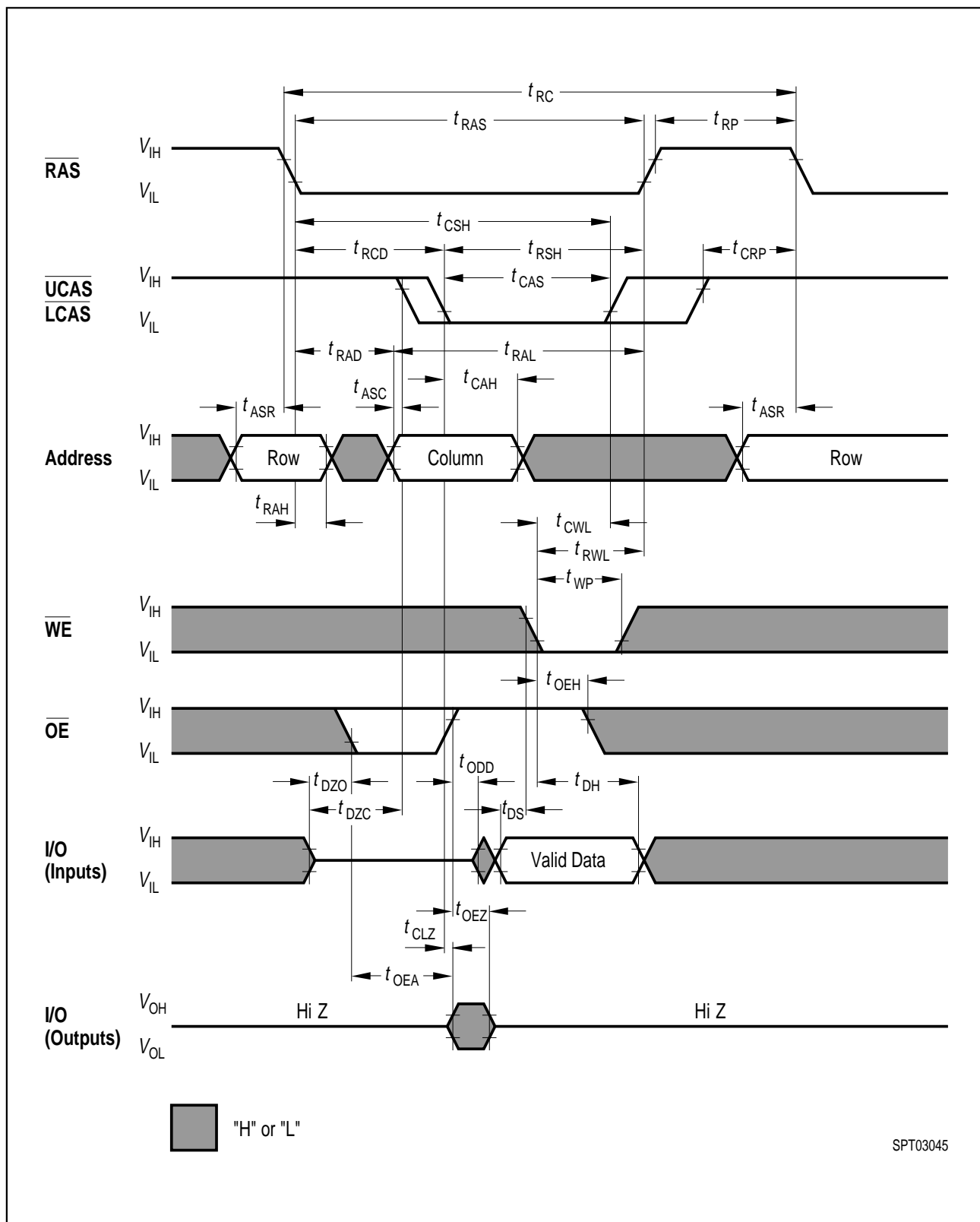

Write Cycle (\overline{OE} Controlled Write)

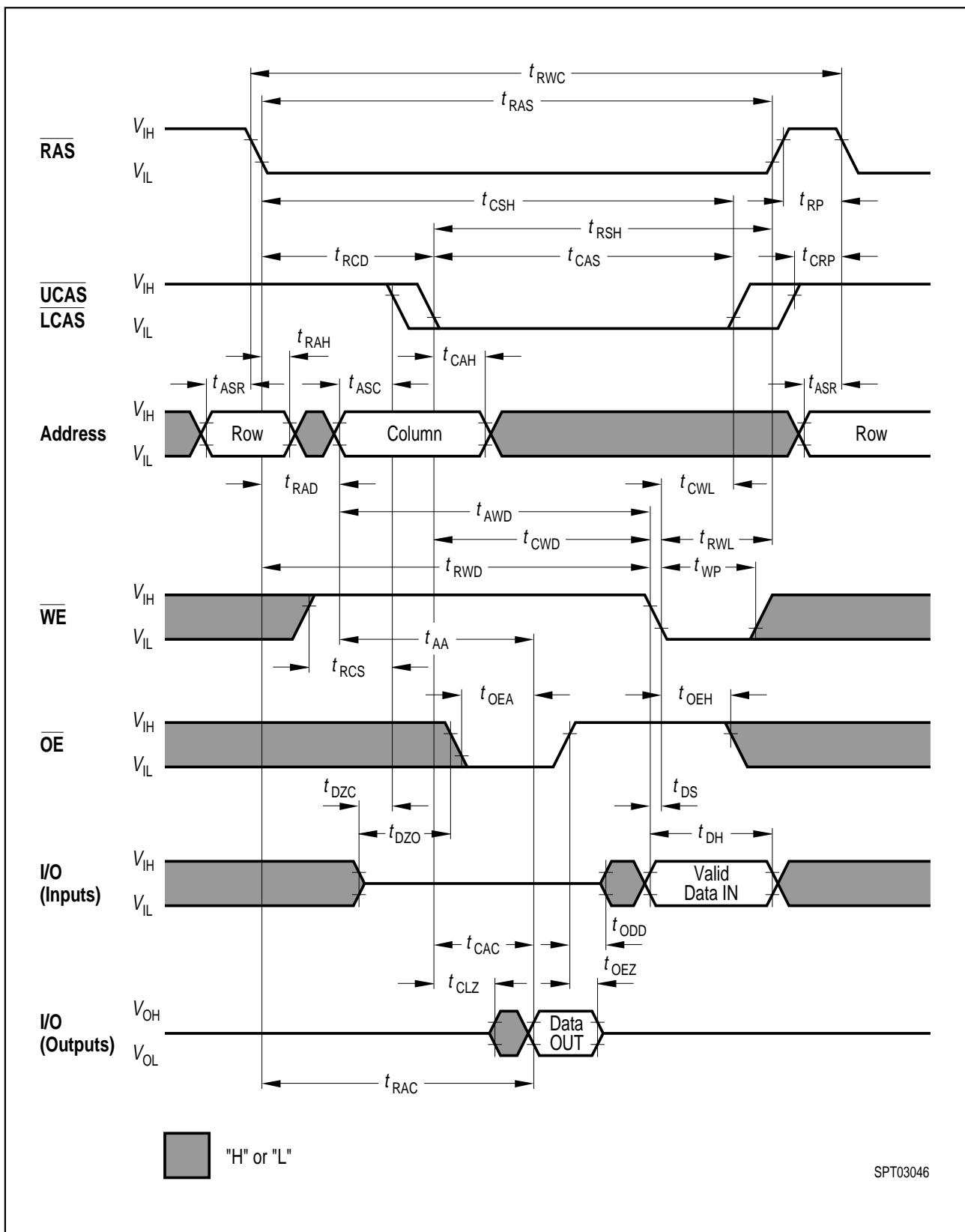

Read-Write (Read-Modify-Write) Cycle

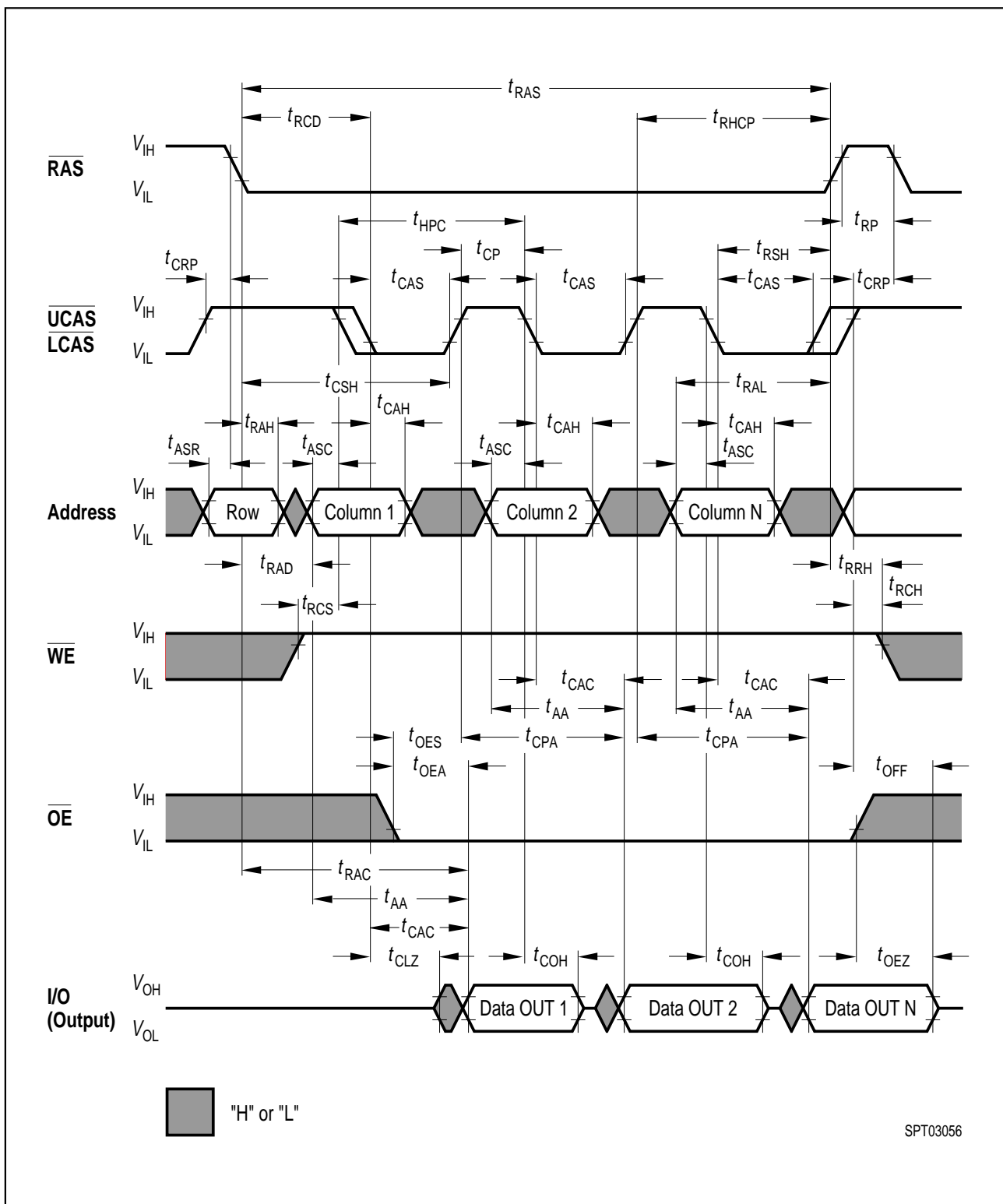

Hyper Page Mode (EDO) Read Cycle

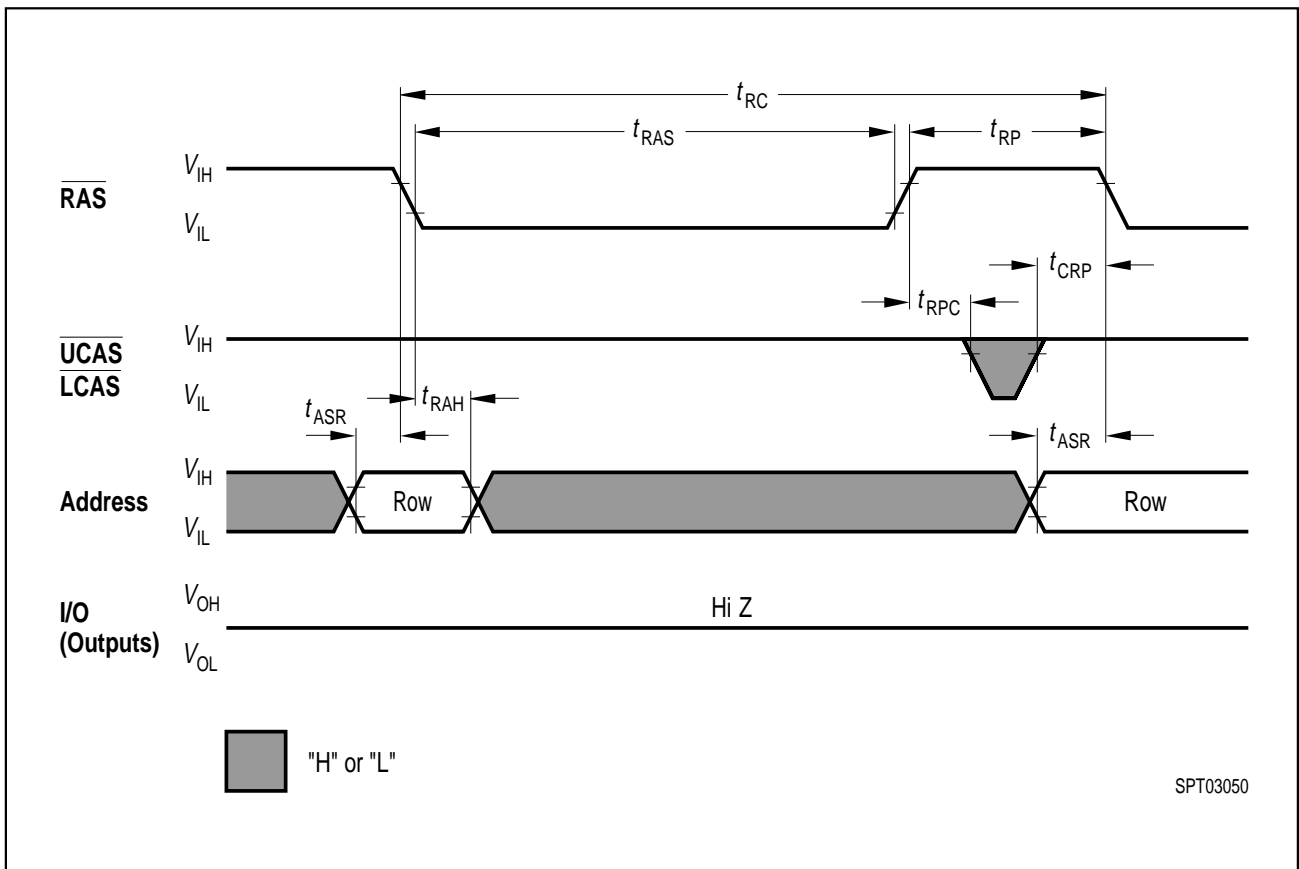

RAS-only Refresh Cycle

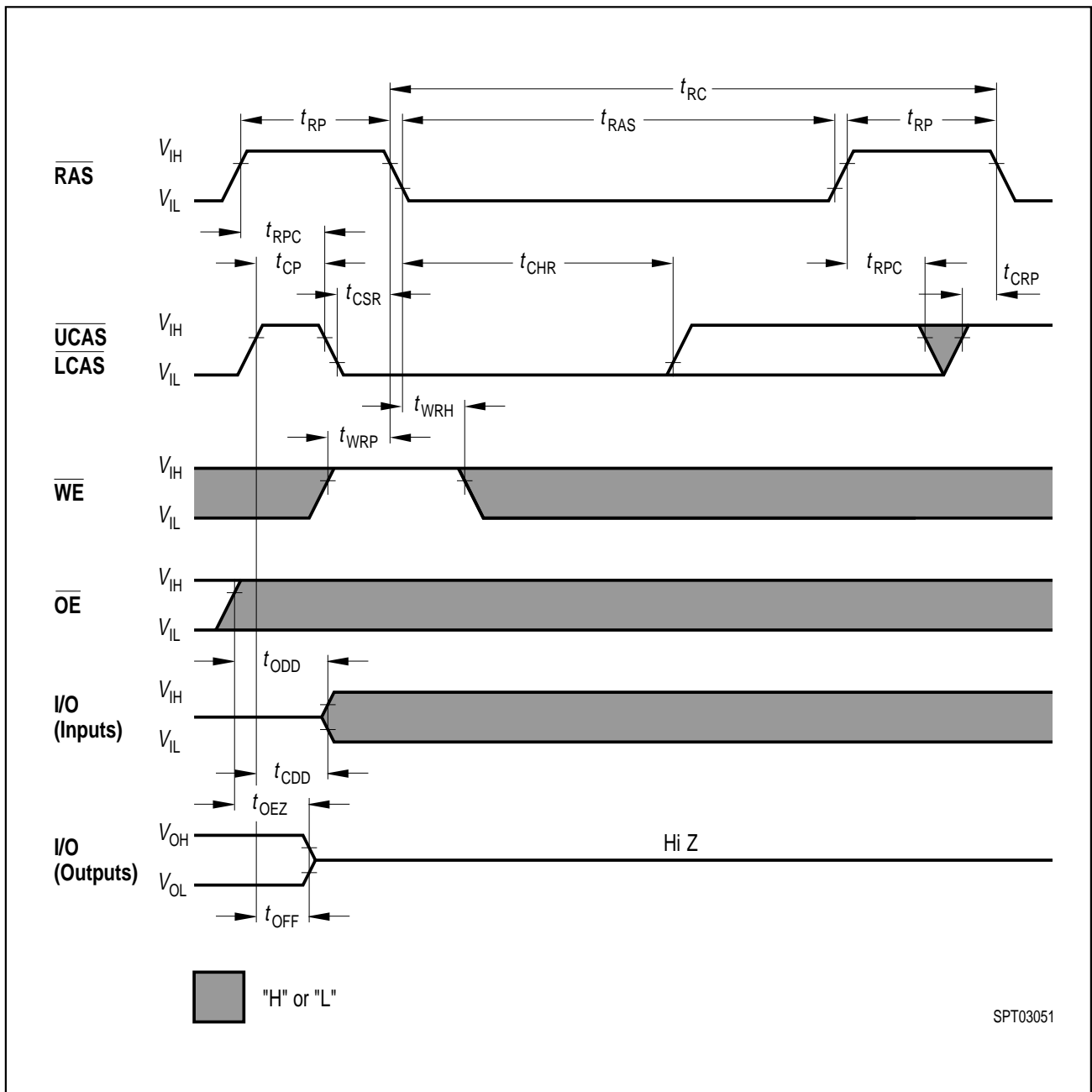

CAS-before-RAS Refresh Cycle

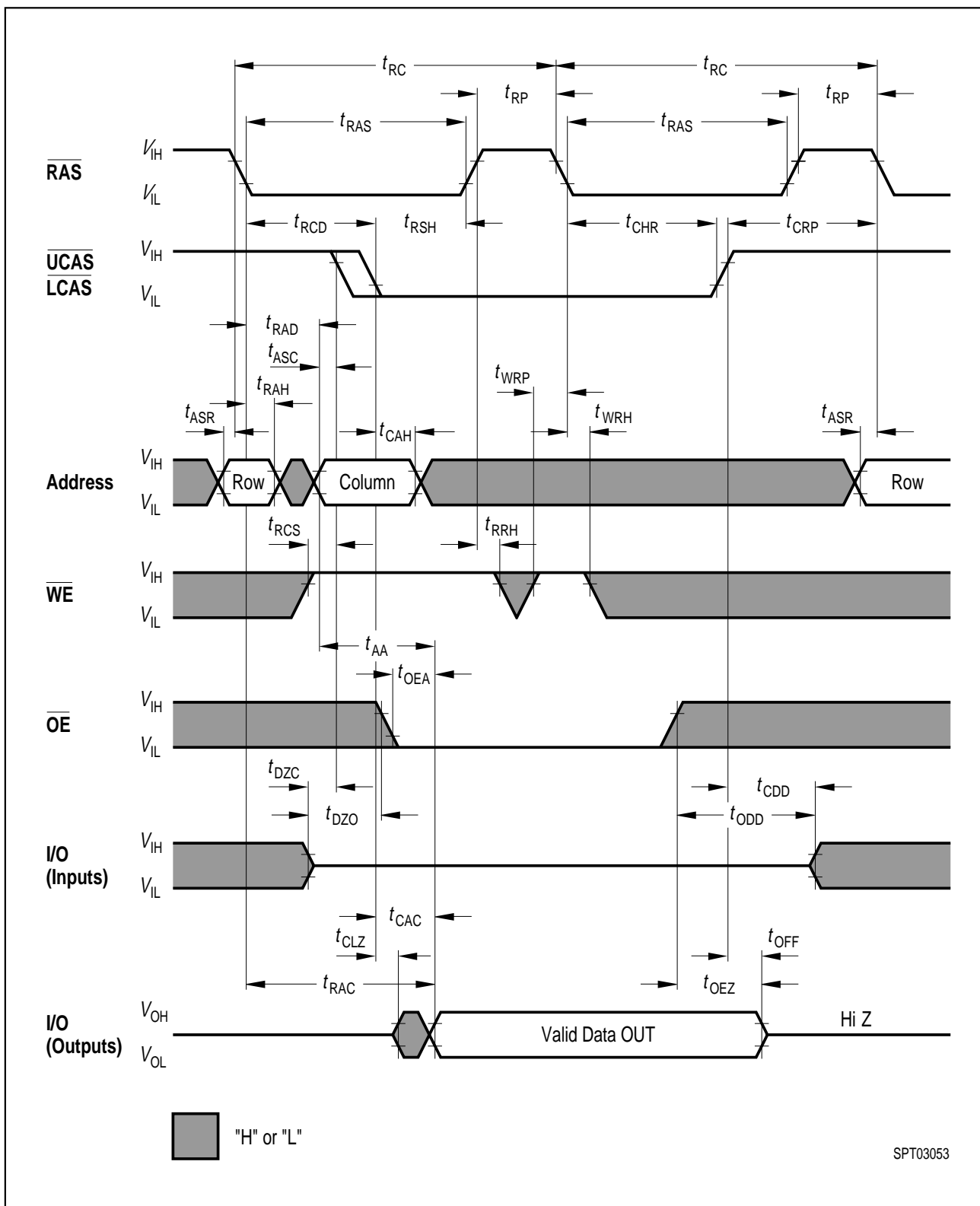

Hidden Refresh Cycle (Read)

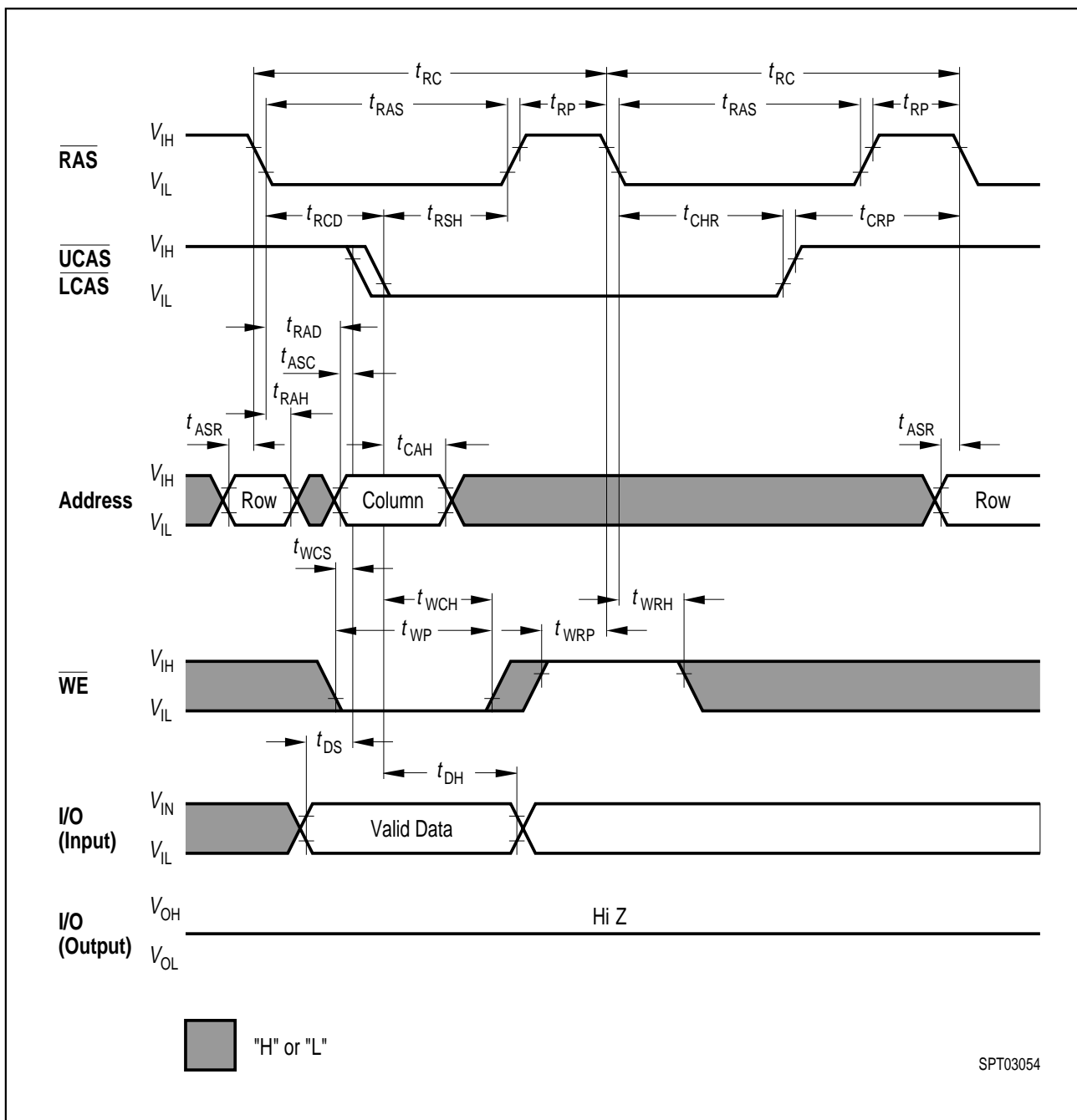

Hidden Refresh Cycle (Early Write)

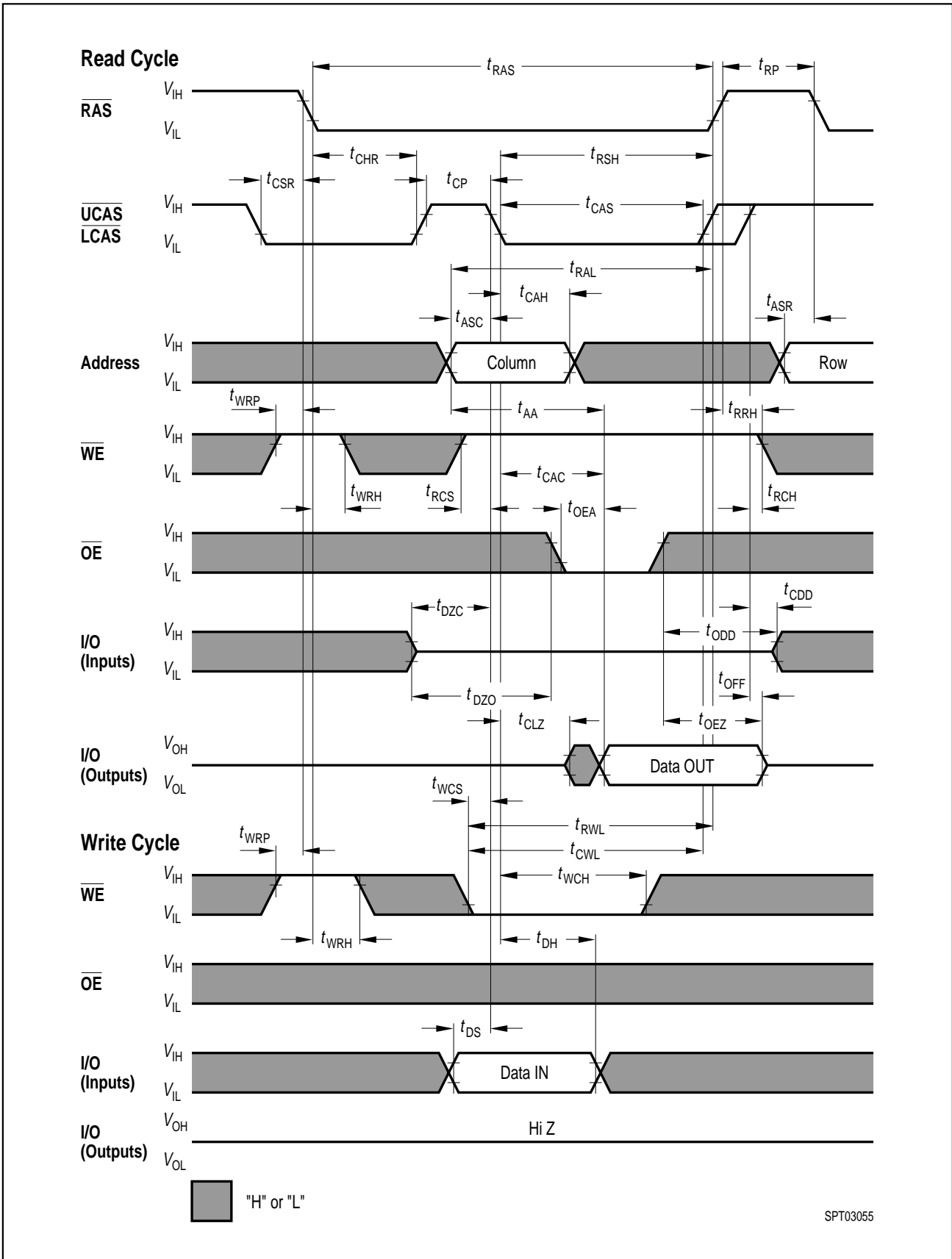

CAS-before-RAS Refresh Counter Test Cycle

Package Outlines

Plastic Package P-SOJ-42-1 (SMD) (400mil)
 (Plastic small outline J-leaded)

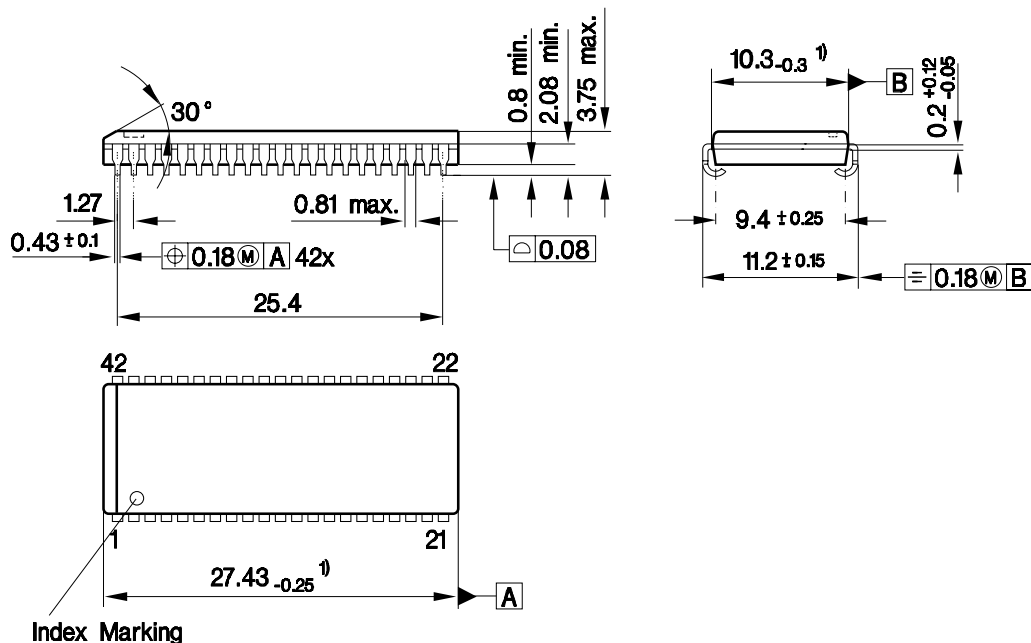

1) Does not include plastic or metal protrusion of 0.25 max. per side

GPJ05853

Sorts of Packing

Package outlines for tubes, trays etc. are contained in our Data Book "Package Information".

SMD = Surface Mounted Device

Dimensions in mm

Plastic Package P-TSOPII-50/44-1 (400 mil) (SMD)
 (Plastic Thin Small Outline Package (Type II))

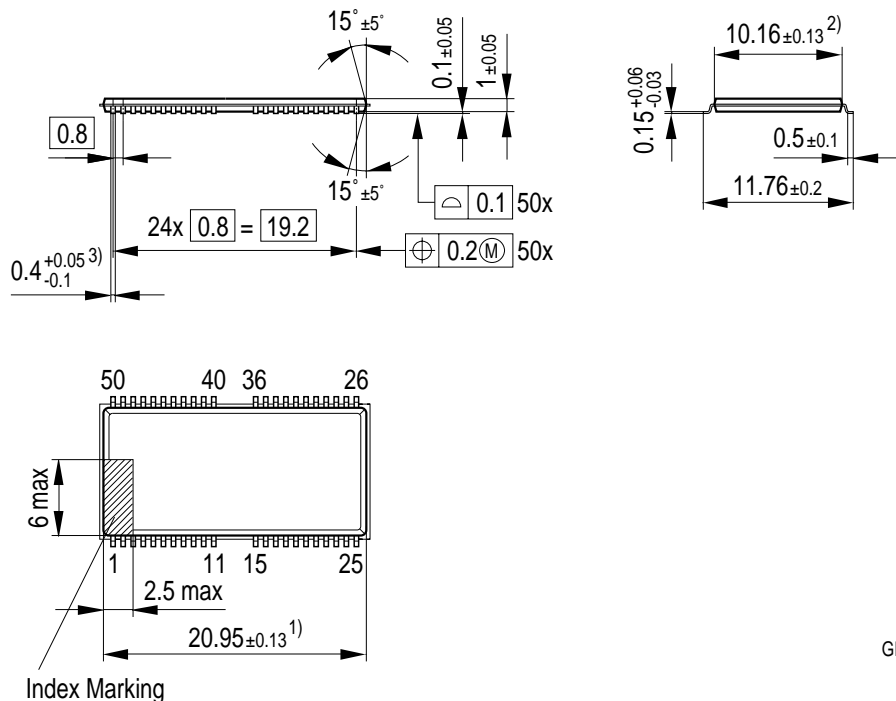

GPX05958

- 1) Does not include plastic or metal protrusion of 0.15 max per side
- 2) Does not include plastic protrusion of 0.25 max per side
- 3) Does not include dambar protrusion of 0.13 max per side

Sorts of Packing

Package outlines for tubes, trays etc. are contained in our Data Book "Package Information".

SMD = Surface Mounted Device

Dimensions in mm



LittleDiode supplies new, hard to find or obsolete electronic components and semiconductors all over the world.

With over two million different components listed you are sure to find the part you need.

Feel free to visit us today at our online store:

LittleDiode.com

Looking forward to providing you with the best possible service.