

Advanced Information

- 262 144 words by 16-bit organization
- 0 to 70 °C operating temperature
- Fast access and cycle time
- $\overline{\text{RAS}}$ access time:
50 ns (-50 version)
60 ns (-60 version)
- $\overline{\text{CAS}}$ access time:
15ns (-50, -60 version)
- Cycle time:
95 ns (-50 version)
110 ns (-60 version)
- Fast page mode cycle time
35 ns (-50 version)
40 ns (-60 version)
- Single + 5.0 V ($\pm 10\%$) supply with a built-in VBB generator
- Low Power dissipation
max. 1045 mW active (-50 version)
max. 935 mW active (-60 version)
- Standby power dissipation
11 mW standby (TTL)
5.5 mW max. standby (CMOS)
- Output unlatched at cycle end allows two-dimensional chip selection
- Read, write, read-modify write, $\overline{\text{CAS}}$ -before- $\overline{\text{RAS}}$ refresh, $\overline{\text{RAS}}$ -only refresh, hidden-refresh and fast page mode capability
- 2 $\overline{\text{CAS}}$ / 1 $\overline{\text{WE}}$ control
- All inputs and outputs TTL-compatible
- 512 refresh cycles / 16 ms
- Plastic Packages:
P-SOJ-40-1 400 mil width

The HYB 514171BJ is a 4 MBit dynamic RAM organized as 262 144 words by 16-bit. The HYB 514171BJ utilizes CMOS silicon gate process as well as advanced circuit techniques to provide wide operation margins, both internally and for the system user. Multiplexed address inputs permit the HYB 514171BJ to be packed in a standard plastic 400 mil wide P-SOJ-40-1 package. This package size provides high system bit densities and is compatible with commonly used automatic testing and insertion equipment. System oriented features include single + 5 V ($\pm 10\%$) power supply, direct interfacing with high performance logic device families such as Schottky TTL.

Ordering Information

Type	Ordering Code	Package	Description
HYB 514171BJ-50	Q67100-Q2021	P-SOJ-40-1 400 mil	50 ns 256k × 16 DRAM
HYB 514171BJ-60	Q67100-Q727	P-SOJ-40-1 400 mil	60 ns 256k × 16 DRAM

Truth Table

$\overline{\text{RAS}}$	$\overline{\text{LCAS}}$	$\overline{\text{UCAS}}$	$\overline{\text{WE}}$	$\overline{\text{OE}}$	I/O1 - I/O8	I/O9 - I/O16	Operation
H	H	H	H	H	High-Z	High-Z	Standby
L	H	H	H	H	High-Z	High-Z	Refresh
L	L	H	H	L	Dout	High-Z	Lower byte read
L	H	L	H	L	High-Z	Dout	Upper byte read
L	L	L	H	L	Dout	Dout	Word read
L	L	H	L	H	Din	Don't care	Lower byte write
L	H	L	L	H	Don't care	Din	Upper byte write
L	L	L	L	H	Din	Din	Word write
L	L	L	H	H	High-Z	High-Z	–

Pin Names

A0 - A8	Address Inputs
$\overline{\text{RAS}}$	Row Address Strobe
$\overline{\text{UCAS}}, \overline{\text{LCAS}}$	Column Address Strobe
$\overline{\text{WE}}$	Read/Write Input
$\overline{\text{OE}}$	Output Enable
I/O1 - I/O16	Data Input/Output
V_{CC}	Power Supply (+ 5 V)
V_{SS}	Ground (0 V)
N.C.	No Connection

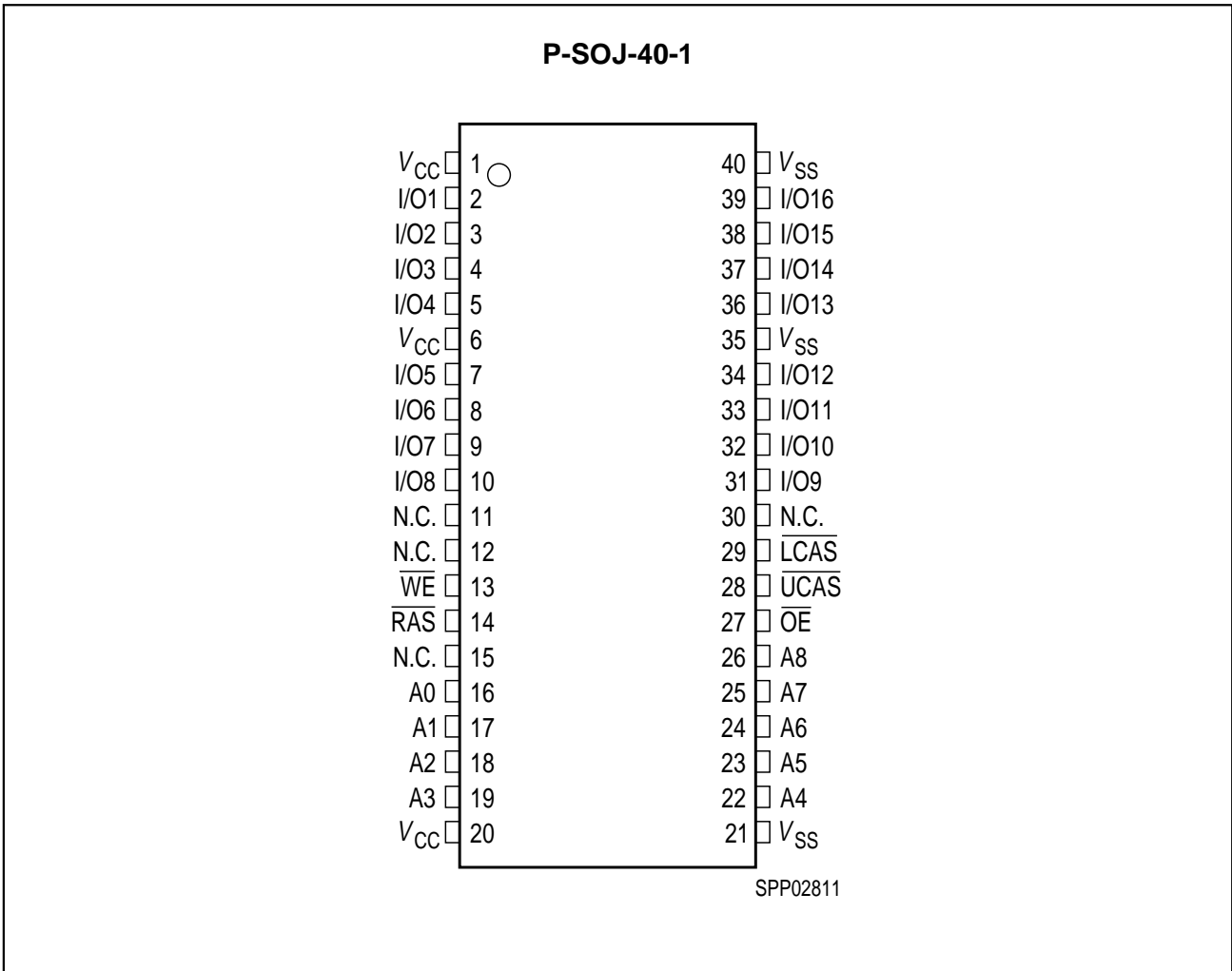

Pin Configuration
 (top view)

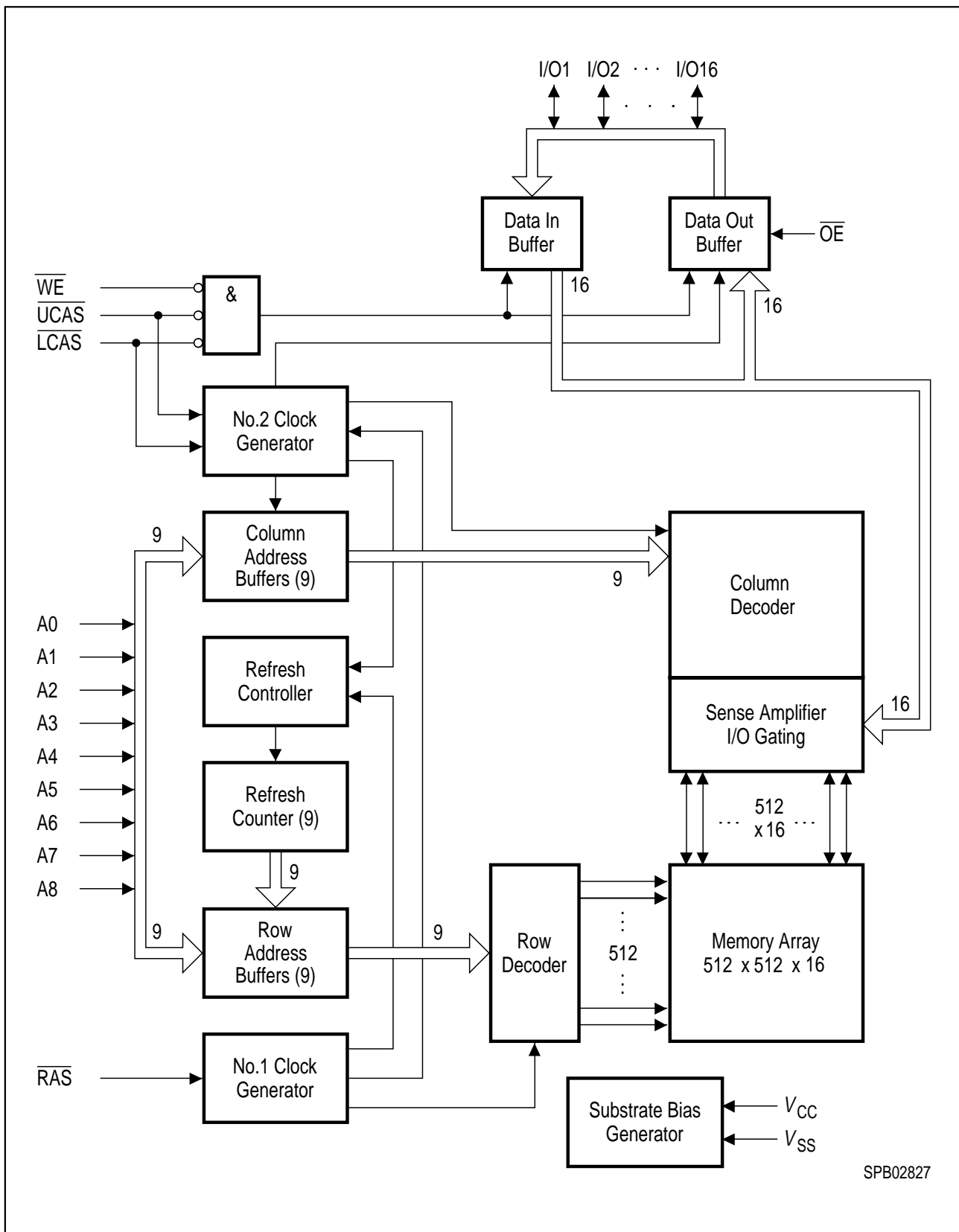

Block Diagram

Absolute Maximum Ratings

Operating temperature range 0 to + 70 °C
 Storage temperature range..... – 55 to + 150 °C
 Input/output voltage – 1 to 6 V
 Power supply voltage..... – 1 to 6 V
 Data out current (short circuit) 50 mA

Note: Stresses above those listed under “Absolute Maximum Ratings” may cause permanent damage of the device. Exposure to absolute maximum rating conditions for extended periods may affect device reliability.

DC Characteristics

$T_A = 0$ to 70 °C; $V_{SS} = 0$ V; $V_{CC} = 5$ V \pm 10 %, $t_T = 5$ ns

Parameter	Symbol	Limit Values		Unit	Notes
		min.	max.		
Input high voltage	V_{IH}	2.4	$V_{CC} + 0.5$	V	1
Input low voltage	V_{IL}	– 1.0	0.8	V	1
TTL Output high voltage ($I_{OUT} = -5.0$ mA)	V_{OH}	2.4	–	V	1
TTL Output low voltage ($I_{OUT} = 4.2$ mA)	V_{OL}	–	0.4	V	1
Input leakage current, any input (0 V < $V_{IN} < V_{CC} + 0.3$ V, all other inputs = 0 V)	$I_{I(L)}$	– 10	10	μ A	1
Output leakage current (DO is disabled, 0 V < $V_{OUT} < V_{CC}$)	$I_{O(L)}$	– 10	10	μ A	1
Average V_{CC} supply current -50 version -60 version	I_{CC1}	–	190 170	mA	2, 3, 4
Standby V_{CC} supply current ($\overline{RAS} = \overline{LCAS} = \overline{UCAS} = \overline{WE} = V_{IH}$)	I_{CC2}	–	2	mA	
Average V_{CC} supply current during \overline{RAS} -only refresh cycles -50 version -60 version	I_{CC3}	–	190 170	mA	2, 4
Average V_{CC} supply current during fast page mode operation -50 version -60 version	I_{CC4}	–	160 150	mA	2, 3, 4
Standby V_{CC} supply current ($\overline{RAS} = \overline{LCAS} = \overline{UCAS} = \overline{WE} = V_{CC} - 0.2$ V)	I_{CC5}	–	1	mA	1
Average V_{CC} supply current during \overline{CAS} -before- \overline{RAS} refresh mode -50 version -60 version	I_{CC6}	–	190 170	mA	2, 4

Capacitance

$T_A = 0$ to 70 °C; $V_{CC} = 5$ V \pm 10 %, $f = 1$ MHz

Parameter	Symbol	Limit Values		Unit
		min.	max.	
Input capacitance (A0 to A8)	C_{I1}	–	6	pF
Input capacitance (\overline{RAS} , \overline{UCAS} , \overline{LCAS} , \overline{WE} , \overline{OE})	C_{I2}	–	7	pF
Output capacitance (I/O1 to I/O16)	C_{I0}	–	7	pF

AC Characteristics ^{5, 6}

$T_A = 0$ to 70 °C; $V_{SS} = 0$ V; $V_{CC} = 5$ V \pm 10 %, $t_T = 5$ ns

Parameter	Symbol	Limit Values				Unit	Note
		-50		-60			
		min.	max.	min.	max.		

Common Parameters

Random read or write cycle time	t_{RC}	95	–	110	–	ns	
\overline{RAS} precharge time	t_{RP}	35	–	40	–	ns	
\overline{RAS} pulse width	t_{RAS}	50	10k	60	10k	ns	
\overline{CAS} pulse width	t_{CAS}	15	10k	15	10k	ns	
Row address setup time	t_{ASR}	0	–	0	–	ns	
Row address hold time	t_{RAH}	10	–	10	–	ns	
Column address setup time	t_{ASC}	0	–	0	–	ns	
Column address hold time	t_{CAH}	10	–	15	–	ns	
\overline{RAS} to \overline{CAS} delay time	t_{RCD}	20	35	20	45	ns	
\overline{RAS} to column address delay time	t_{RAD}	15	25	15	30	ns	
\overline{RAS} hold time	t_{RSH}	15	–	15	–	ns	
\overline{CAS} hold time	t_{CSH}	50	–	60	–	ns	
\overline{CAS} to \overline{RAS} precharge time	t_{CRP}	5	–	5	–	ns	
Transition time (rise and fall)	t_T	3	50	3	50	ns	⁷
Refresh period	t_{REF}	–	16	–	16	ms	

Read Cycle

Access time from \overline{RAS}	t_{RAC}	–	50	–	60	ns	8, 9
Access time from \overline{CAS}	t_{CAC}	–	15	–	15	ns	8, 9
Access time from column address	t_{AA}	–	25	–	30	ns	8, 10
\overline{OE} access time	t_{OEA}	–	15	–	15	ns	

AC Characteristics (cont'd) ^{5, 6}

$T_A = 0$ to 70 °C; $V_{SS} = 0$ V; $V_{CC} = 5$ V \pm 10 %, $t_T = 5$ ns

Parameter	Symbol	Limit Values				Unit	Note
		-50		-60			
		min.	max.	min.	max.		
Column address to \overline{RAS} lead time	t_{RAL}	25	–	30	–	ns	
Read command setup time	t_{RCS}	0	–	0	–	ns	
Read command hold time	t_{RCH}	0	–	0	–	ns	11
Read command hold time ref. to \overline{RAS}	t_{RRH}	0	–	0	–	ns	11
\overline{CAS} to output in low-Z	t_{CLZ}	0	–	0	–	ns	8
Output buffer turn-off delay from \overline{CAS}	t_{OFF}	0	15	0	20	ns	12
Output buffer turn-off delay from \overline{OE}	t_{OEZ}	0	15	0	20	ns	12
Data to \overline{OE} low delay	t_{DZO}	0	–	0	–	ns	13
\overline{CAS} high to data delay	t_{CDD}	15	–	20	–	ns	14
\overline{OE} high to data delay	t_{ODD}	15	–	20	–	ns	14

Write Cycle

Write command hold time	t_{WCH}	10	–	10	–	ns	
Write command pulse width	t_{WCP}	10	–	10	–	ns	
Write command setup time	t_{WCS}	0	–	0	–	ns	15
Write command to \overline{RAS} lead time	t_{RWL}	15	–	15	–	ns	
Write command to \overline{CAS} lead time	t_{CWL}	15	–	15	–	ns	
Data setup time	t_{DS}	0	–	0	–	ns	16
Data hold time	t_{DH}	10	–	15	–	ns	16
Data to \overline{CAS} low delay	t_{DZC}	0	–	0	–	ns	13

Read-Modify-Write Cycle

Read-write cycle time	t_{RWC}	140	–	160	–	ns	
\overline{RAS} to \overline{WE} delay time	t_{RWD}	75	–	90	–	ns	15
\overline{CAS} to \overline{WE} delay time	t_{CWD}	40	–	45	–	ns	15
Column address to \overline{WE} delay time	t_{AWD}	50	–	60	–	ns	15
\overline{OE} command hold time	t_{OEH}	15	–	20	–	ns	

Fast Page Mode Cycle

Fast page mode cycle time	t_{PC}	35	–	40	–	ns	
---------------------------	----------	----	---	----	---	----	--

AC Characteristics (cont'd) ^{5, 6}

$T_A = 0$ to 70 °C; $V_{SS} = 0$ V; $V_{CC} = 5$ V \pm 10 %, $t_T = 5$ ns

Parameter	Symbol	Limit Values				Unit	Note
		-50		-60			
		min.	max.	min.	max.		
$\overline{\text{CAS}}$ precharge time	t_{CP}	10	–	10	–	ns	
Access time from $\overline{\text{CAS}}$ precharge	t_{CPA}	–	30	–	35	ns	⁷
$\overline{\text{RAS}}$ pulse width	t_{RASP}	50	200k	60	200k	ns	
$\overline{\text{RAS}}$ hold time from $\overline{\text{CAS}}$ precharge	t_{RHCP}	30	–	35	–	ns	

Fast Page Mode Read-Modify-Write Cycle

Fast page mode read/write cycle time	t_{PRWC}	80	–	90	–	ns	
$\overline{\text{CAS}}$ precharge to $\overline{\text{WE}}$ delay time	t_{CPWD}	55	–	60	–	ns	

$\overline{\text{CAS}}$ -before- $\overline{\text{RAS}}$ Refresh Cycle

$\overline{\text{CAS}}$ setup time	t_{CSR}	5	–	5	–	ns	
$\overline{\text{CAS}}$ hold tim	t_{CHR}	10	–	10	–	ns	
$\overline{\text{RAS}}$ to $\overline{\text{CAS}}$ precharge time	t_{RPC}	0	–	0	–	ns	
Write to $\overline{\text{RAS}}$ precharge time	t_{WRP}	10	–	10	–	ns	
Write to $\overline{\text{RAS}}$ hold time	t_{WRH}	10	–	10	–	ns	

$\overline{\text{CAS}}$ -before- $\overline{\text{RAS}}$ Counter Test Cycle

$\overline{\text{CAS}}$ precharge time	t_{CPT}	25	–	30	–	ns	
--	-----------	----	---	----	---	----	--

Notes

1. All voltages are referenced to V_{SS} .
2. I_{CC} , I_{CC3} , I_{CC4} and I_{CC6} depend on cycle rate.
3. I_{CC1} and I_{CC4} depend on output loading. Specified values are obtained with the output open.
4. Address can be changed once or less while $\overline{RAS} = V_{IL}$. In case of I_{CC4} it can be changed once or less during a page mode cycle
5. An initial pause of 200 μ s is required after power-up followed by 8 \overline{RAS} cycles of which at least one cycle has to be a refresh cycle, before proper device operation is achieved. In case of using the internal refresh counter, a minimum of 8 \overline{CAS} -before- \overline{RAS} initialization cycles instead of 8 \overline{RAS} cycles are required.
6. AC measurements assume $t_T = 5$ ns.
7. $V_{IH(MIN.)}$ and $V_{IL(MAX.)}$ are reference levels for measuring timing of input signals. Transition times are also measured between V_{IH} and V_{IL} .
8. Measured with a load equivalent to 2 TTL loads and 100 pF.
9. Operation within the $t_{RCD(MAX.)}$ limit ensures that $t_{RAC(MAX.)}$ can be met. $t_{RCD(MAX.)}$ is specified as a reference point only. If t_{RCD} is greater than the specified $t_{RCD(MAX.)}$ limit, then access time is controlled by t_{CAC} .
10. Operation within the $t_{RAD(MAX.)}$ limit ensures that $t_{RAC(MAX.)}$ can be met. $t_{RAD(MAX.)}$ is specified as a reference point only. If t_{RAD} is greater than the specified $t_{RAD(MAX.)}$ limit, then access time is controlled by t_{AA} .
11. Either t_{RCH} or t_{RRH} must be satisfied for a read cycle.
12. $t_{OFF(MAX.)}$, $t_{OEZ(MAX.)}$ define the time at which the output achieves the open-circuit conditions and are not referenced to output voltage levels.
13. Either t_{DZC} or t_{DZO} must be satisfied.
14. Either t_{CDD} or t_{ODD} must be satisfied.
15. t_{WCS} , t_{RWD} , t_{CWD} and t_{AWD} are not restrictive operating parameters. They are included in the data sheet as electrical characteristics only. If $t_{WCS} > t_{WCS(MIN.)}$, the cycle is an early write cycle and data out pin will remain open-circuit (high impedance) through the entire cycle; if $t_{RWD} > t_{RWD(MIN.)}$, $t_{CWD} > t_{CWD(MIN.)}$ and $t_{AWD} > t_{AWD(MIN.)}$, the cycle is a read-write cycle and I/O will contain data read from the selected cells. If neither of the above sets of conditions is satisfied, the condition of I/O (at access time) is indeterminate.
16. These parameters are referenced to the \overline{CAS} leading edge in early write cycles and to the \overline{WE} leading edge in read-write cycles.

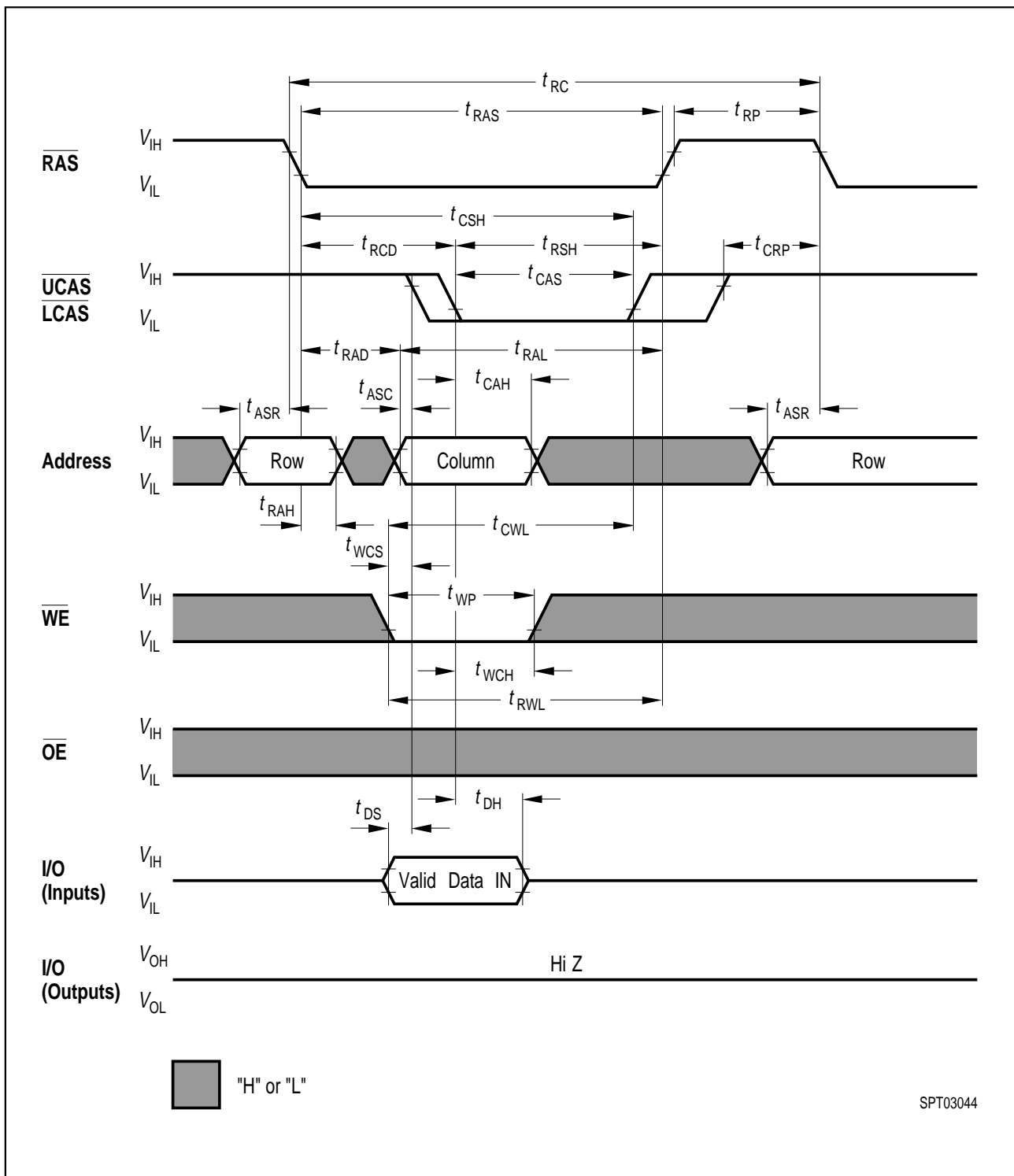

Write Cycle (Early Write)

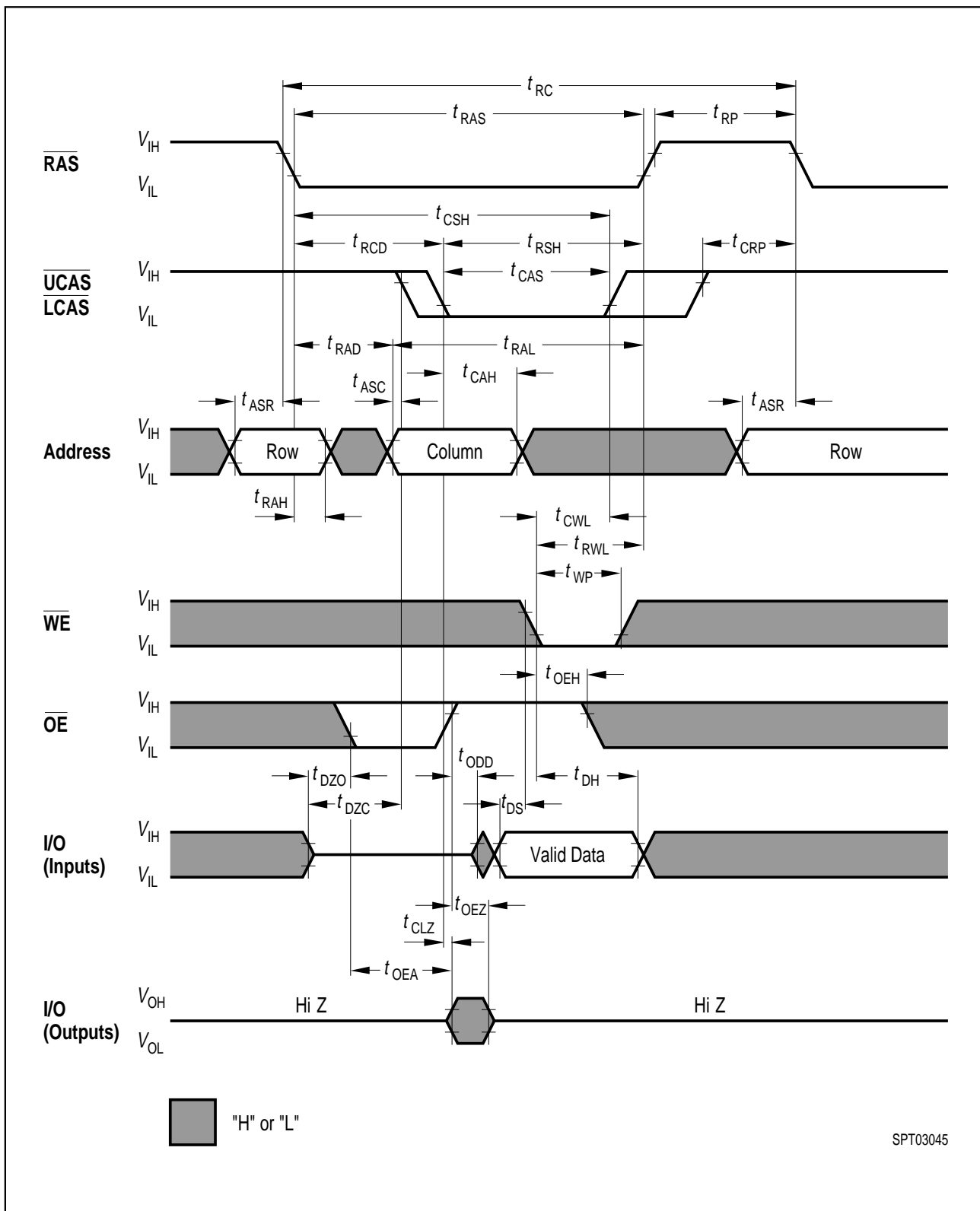

Write Cycle (\overline{OE} Controlled Write)

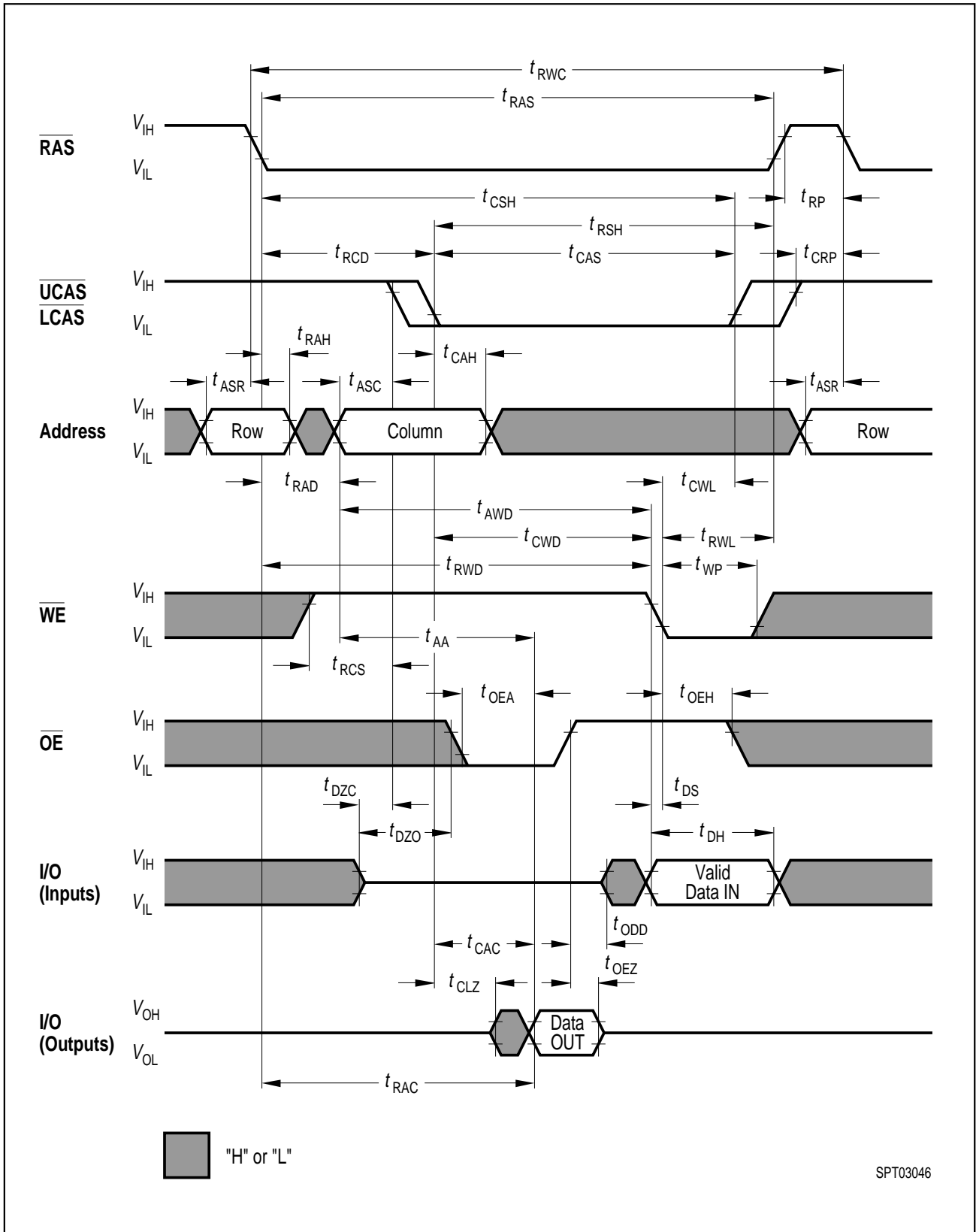

Read-Write (Read-Modify-Write) Cycle

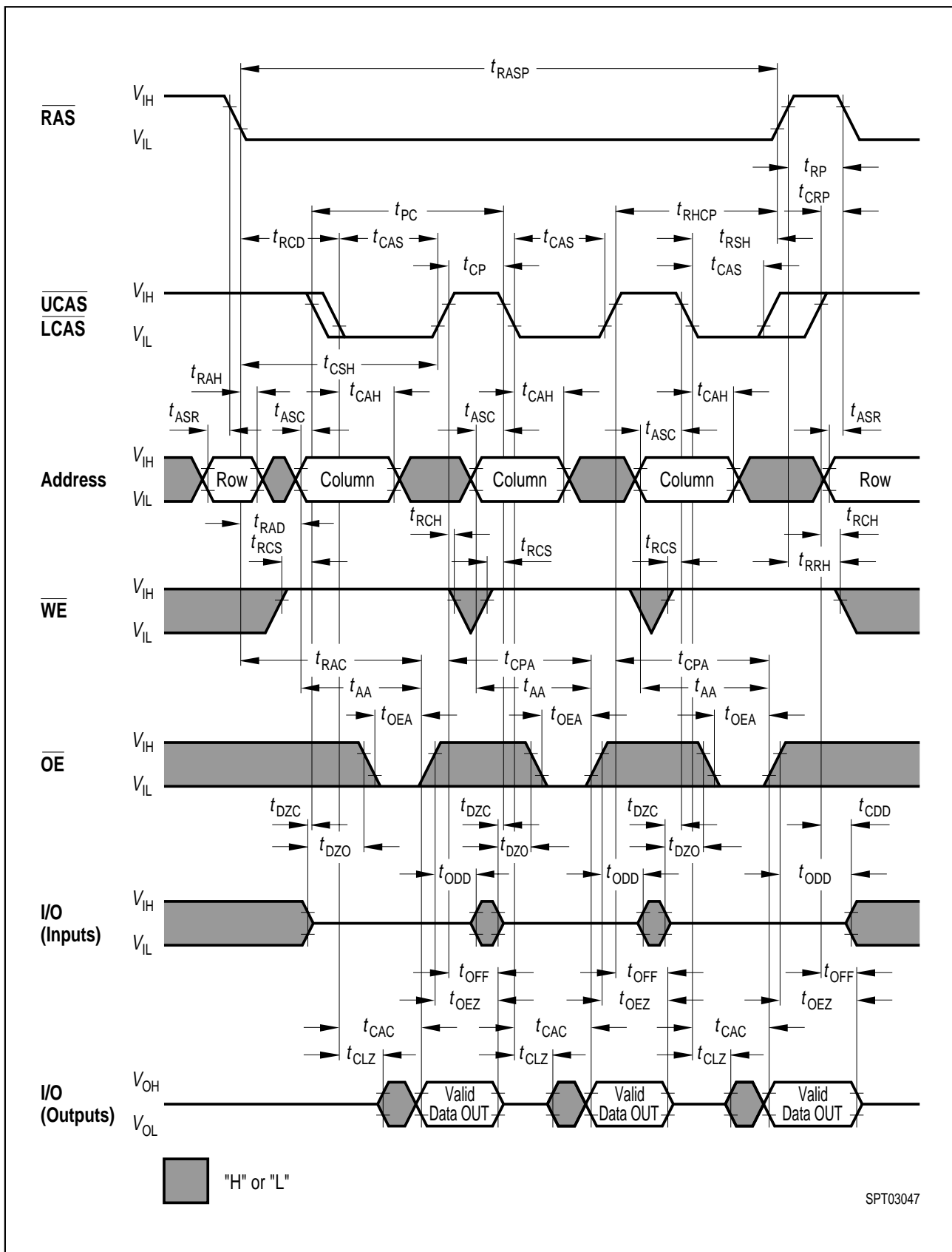

Fast Page Mode Read Cycle

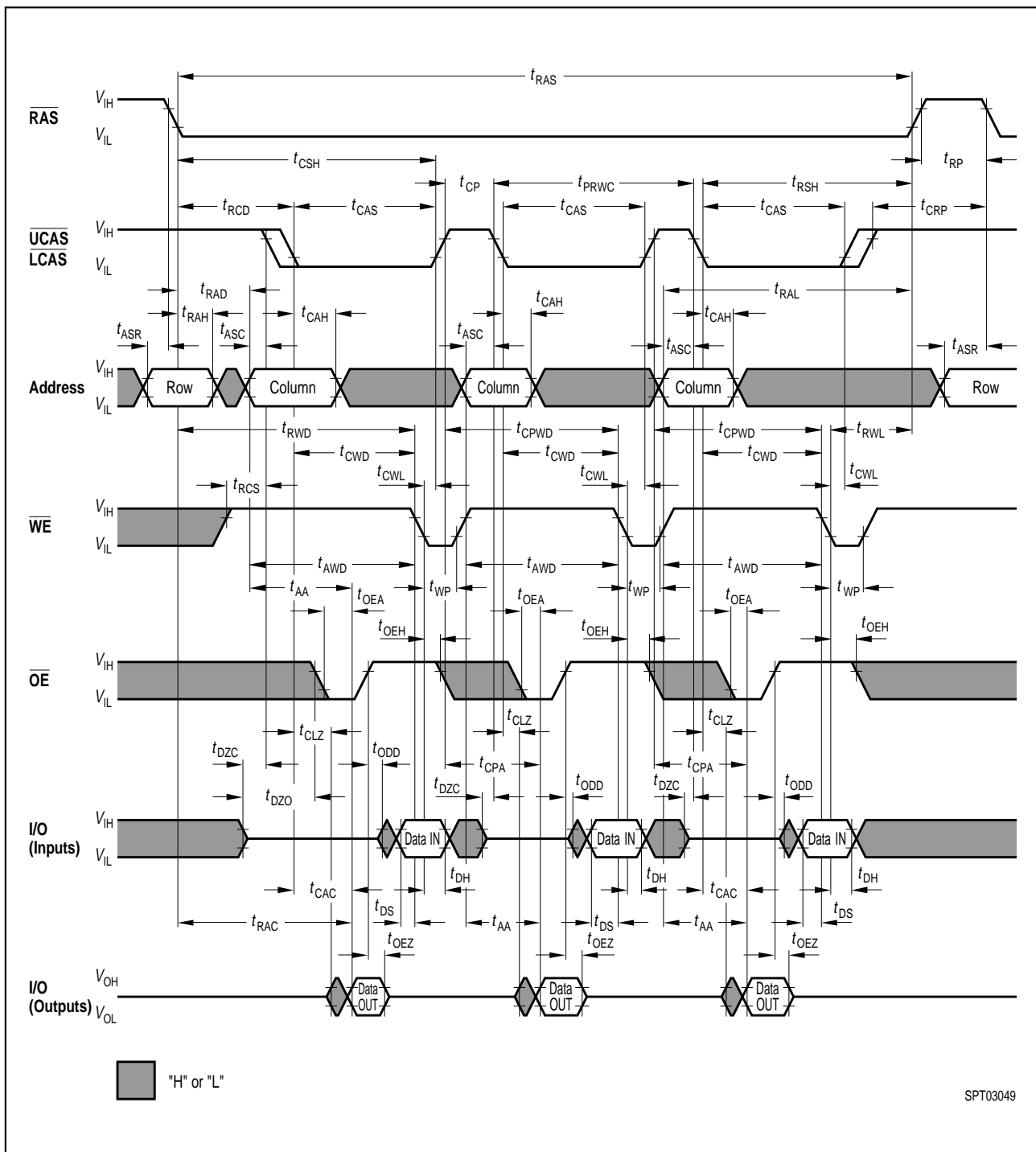

Fast Page Mode Read-Modify-Write Cycle

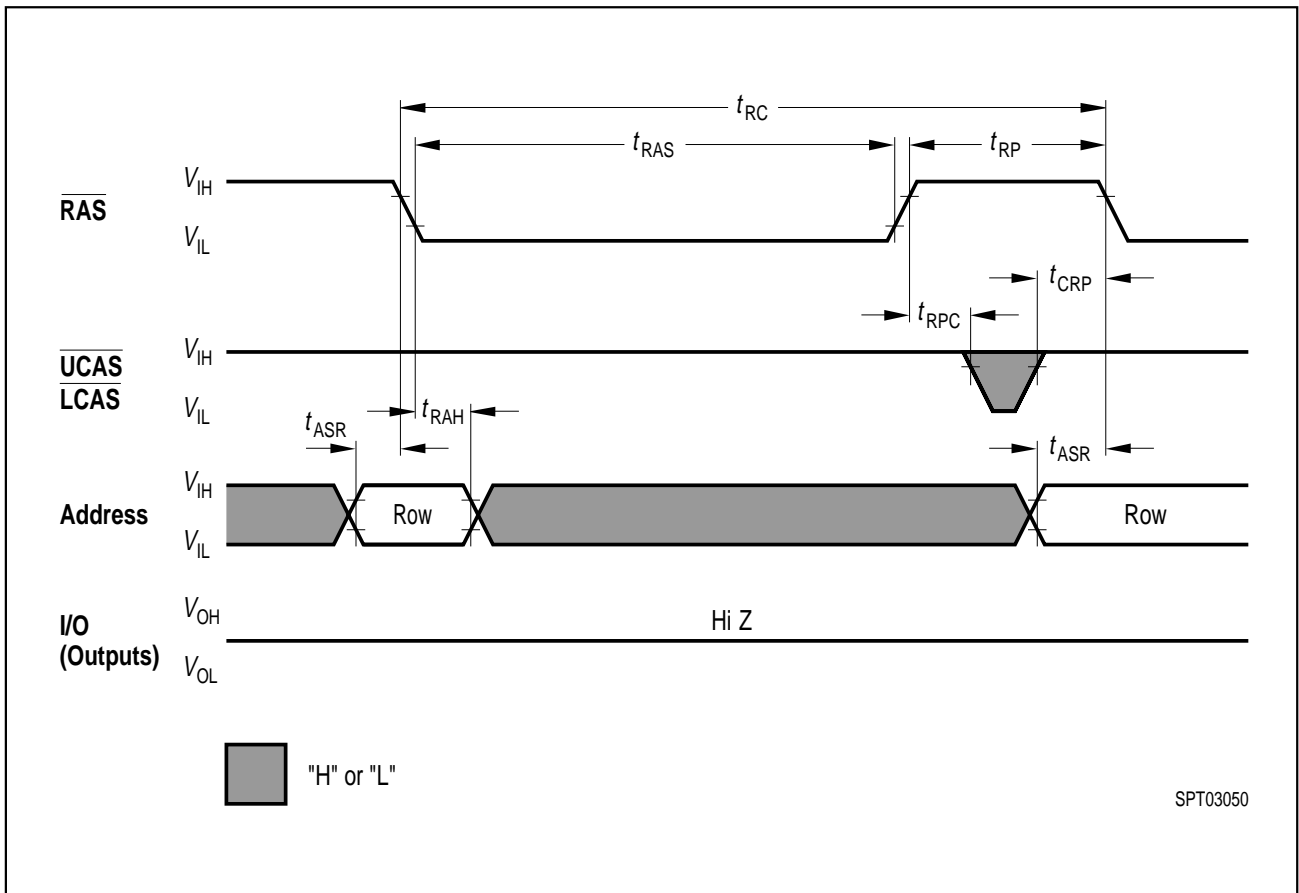

RAS-Only Refresh Cycle

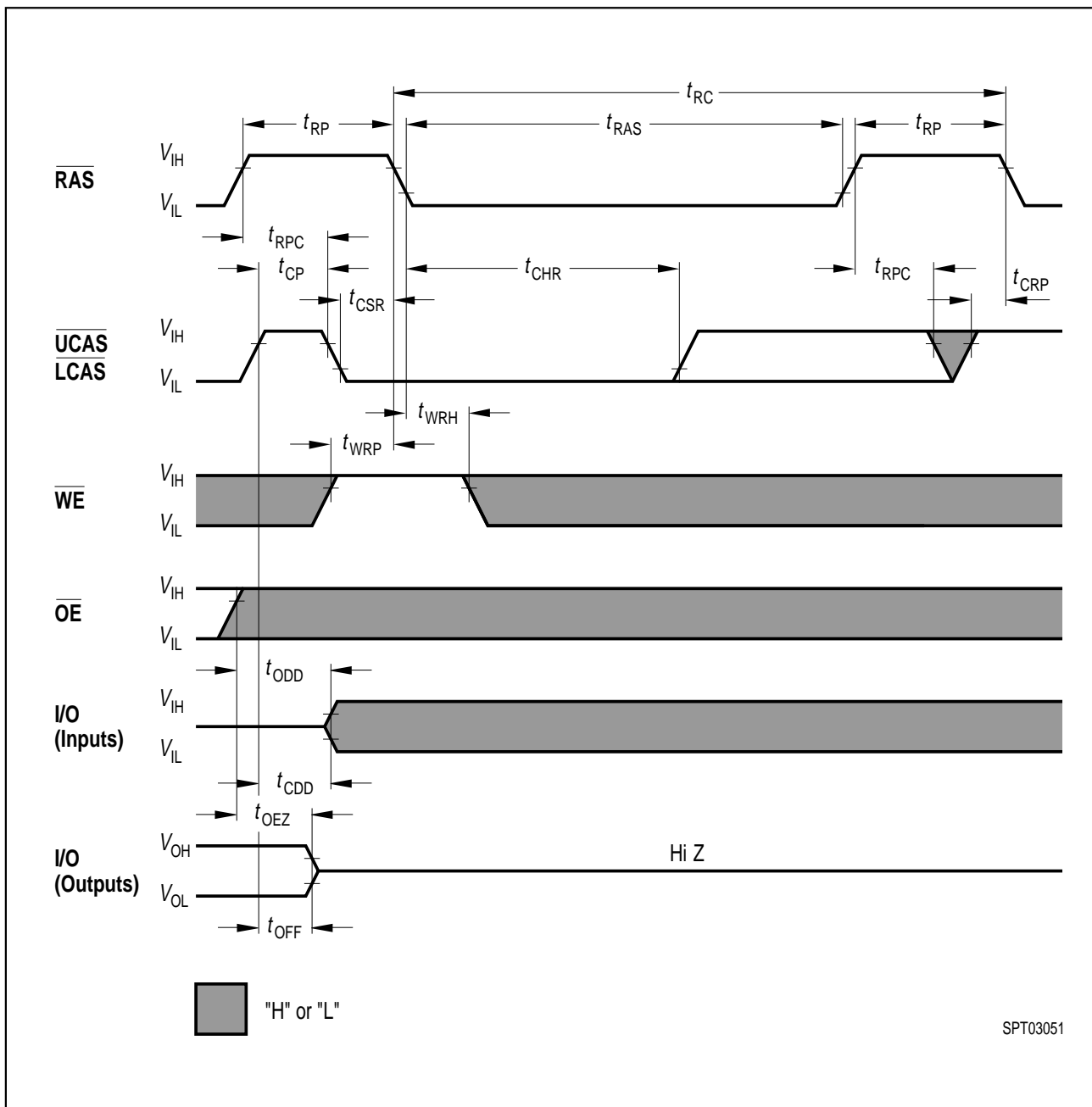

CAS-Before-RAS Refresh Cycle

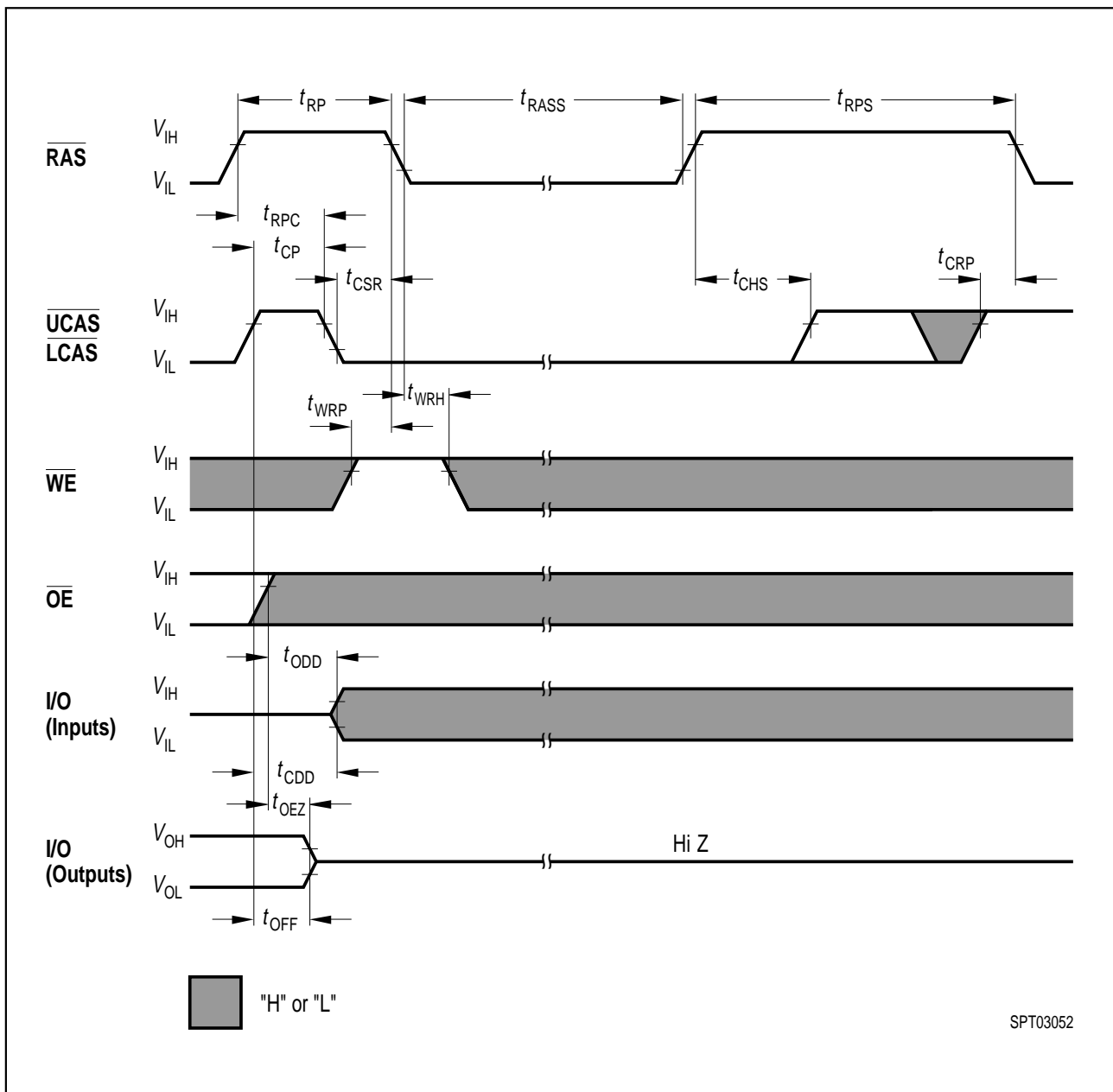

CAS-Before-RAS Self Refresh Cycle

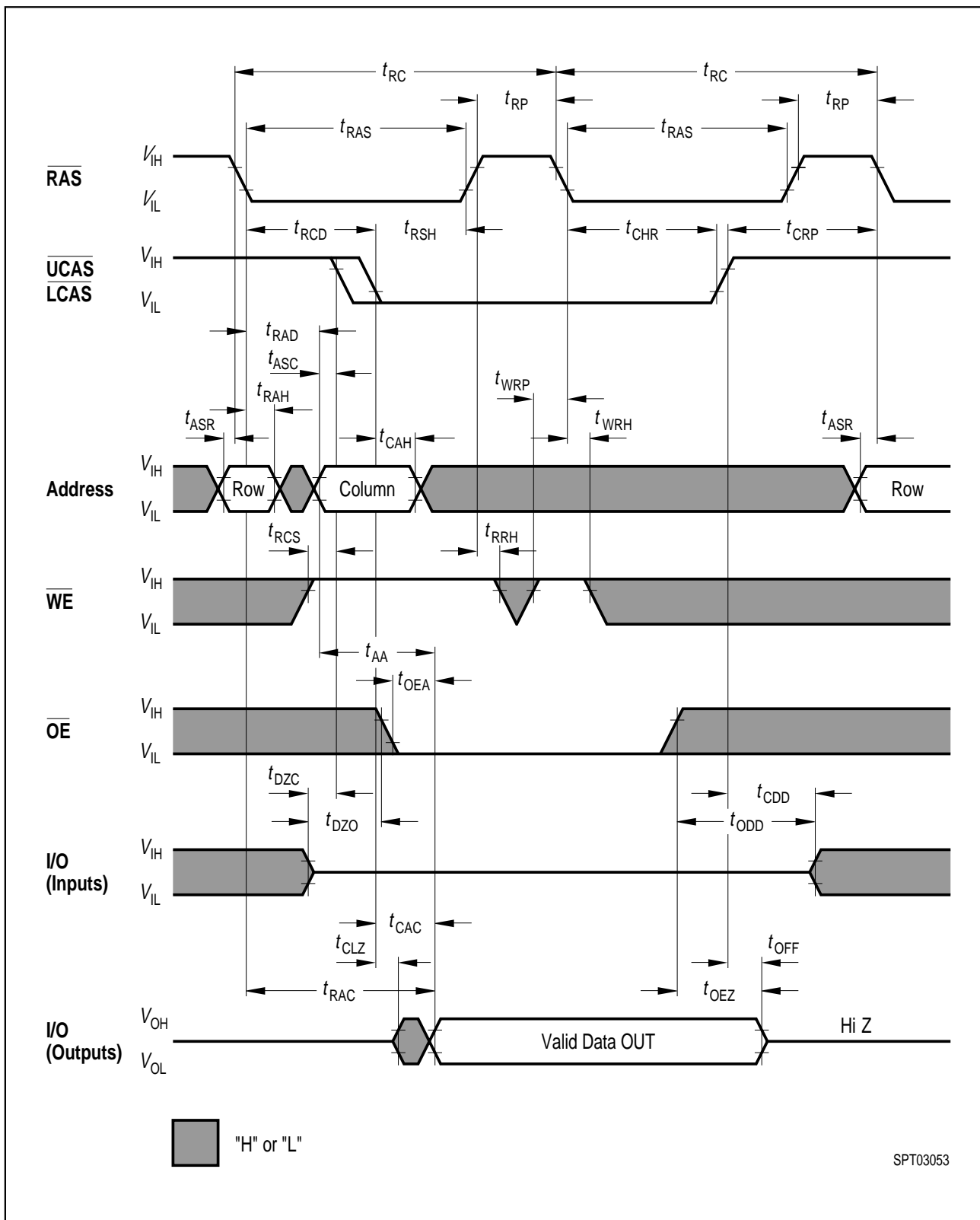

Hidden Refresh Cycle (Read)

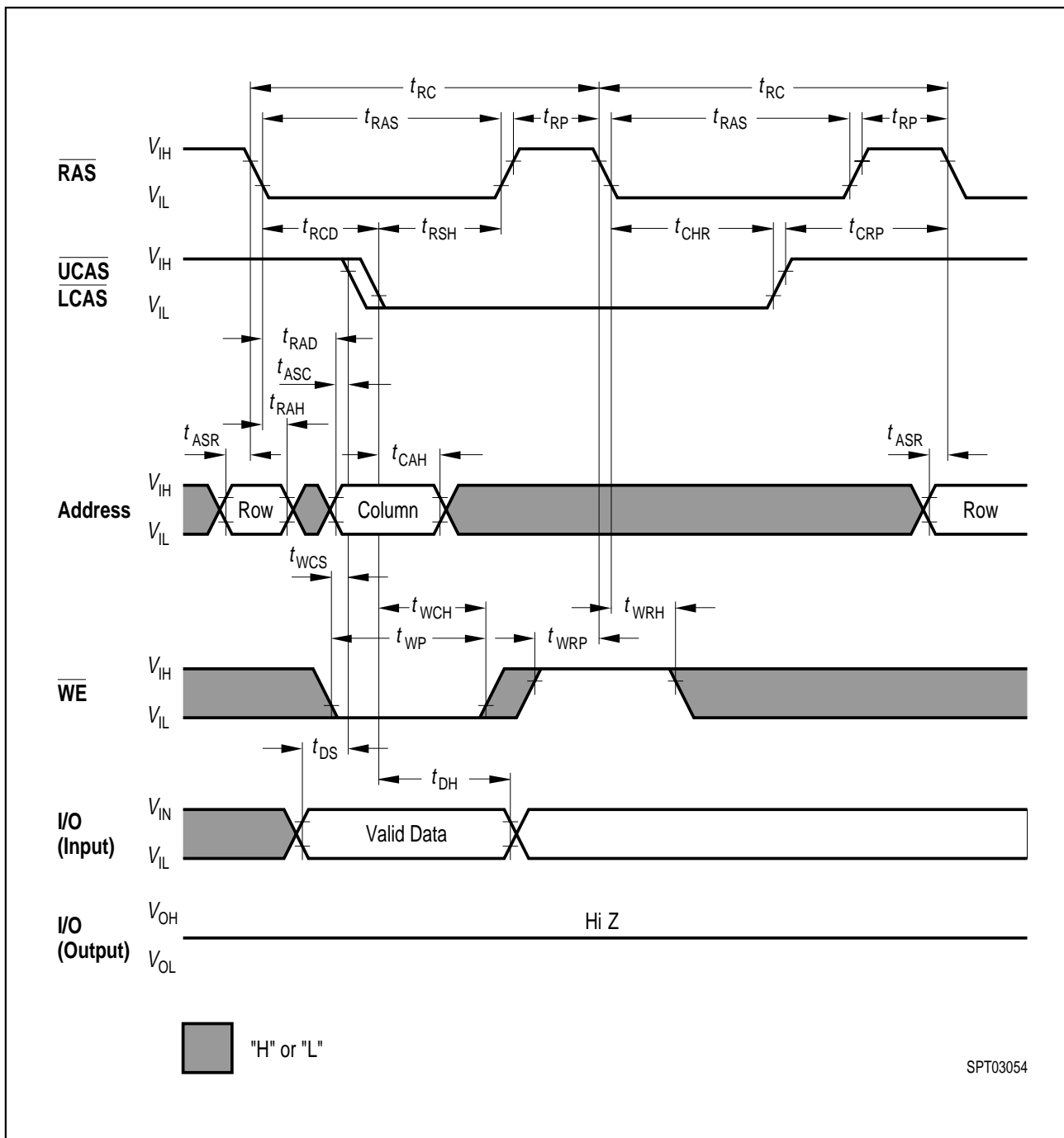

Hidden Refresh Cycle (Early Write)

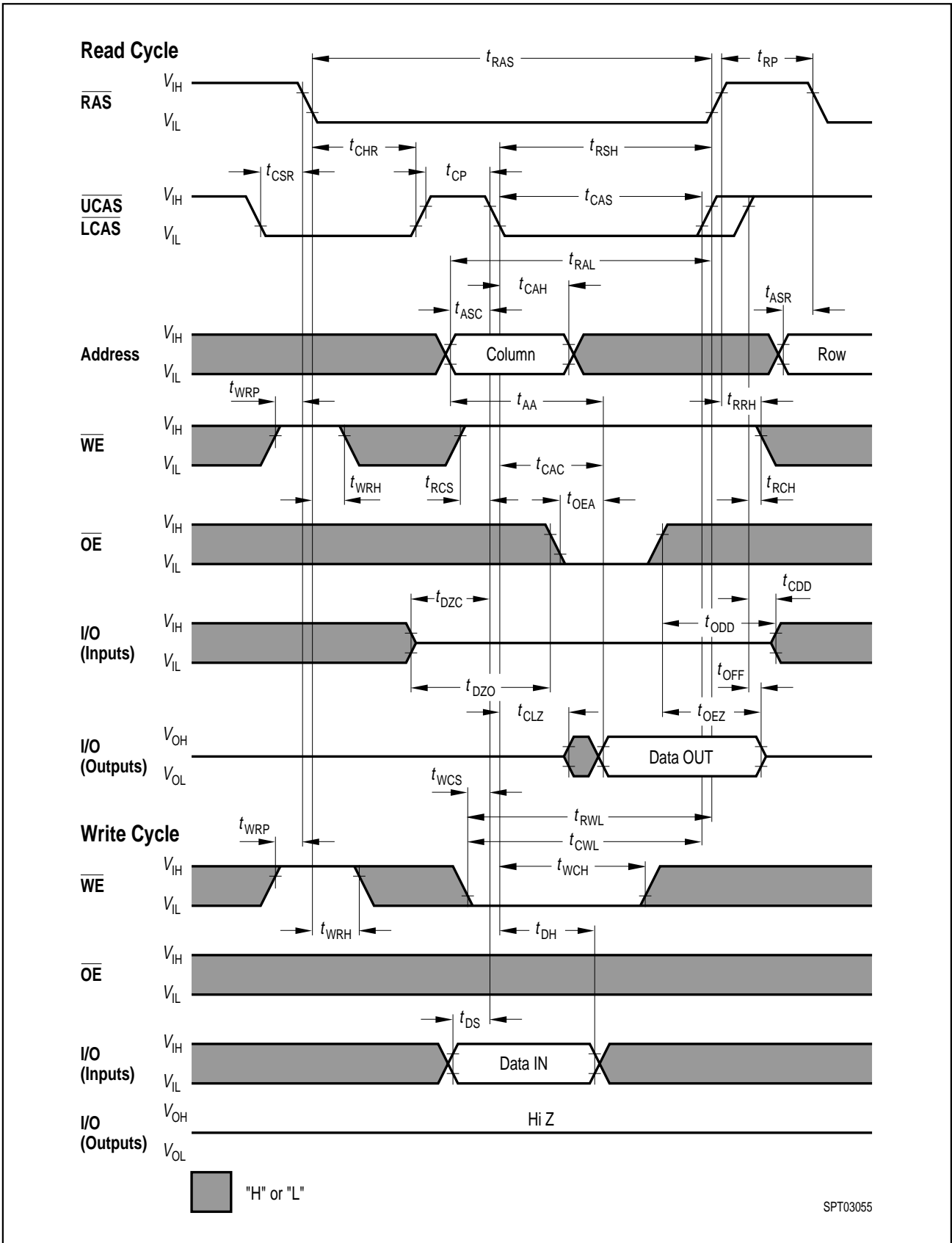

CAS-Before-RAS Refresh Counter Test Cycle

Package Outlines

Plastic Package, P-SOJ- 40-1 (SMD)
(Plastic small outline J-leaded)

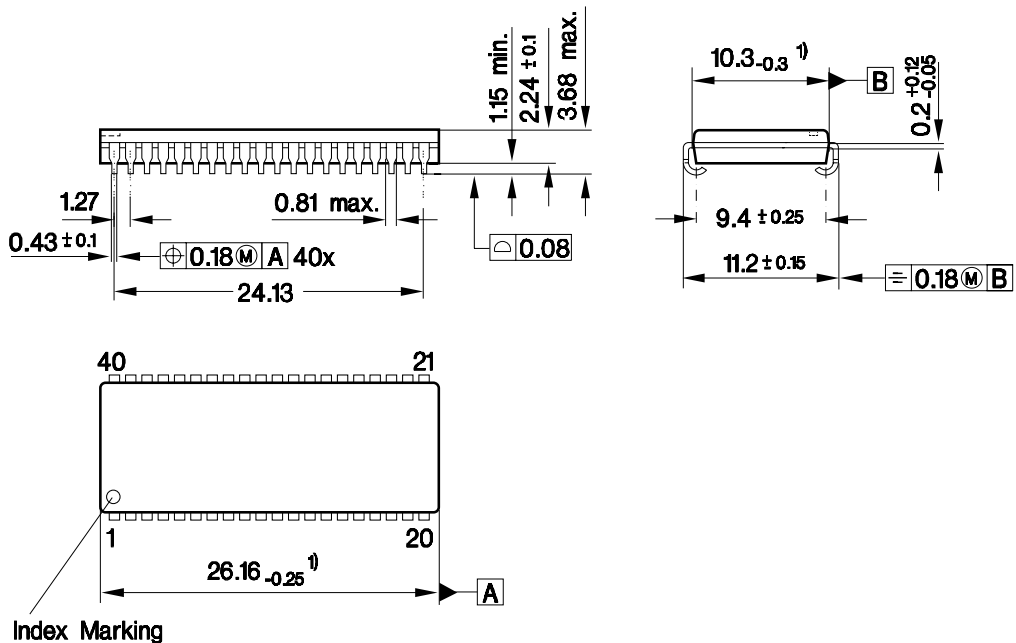

1) Does not include plastic or metal protrusion of 0.25 max. per side

GPJ09018

Sorts of Packing

Package outlines for tubes, trays etc. are contained in our Data Book "Package Information".

SMD = Surface Mounted Device

Dimensions in mm



LittleDiode supplies new, hard to find or obsolete electronic components and semiconductors all over the world.

With over two million different components listed you are sure to find the part you need.

Feel free to visit us today at our online store:

LittleDiode.com

Looking forward to providing you with the best possible service.