

## 512kx8-Bit Dynamic RAM

## HYB 514800BJ -60/-70/-80

### Advanced Information

- 512 288 words by 8-bit organization
- 0 to 70 °C operating temperature
- Fast access and cycle time  
 RAS access time:  
 60 ns (-60 version)  
 70 ns (-70 version)  
 80 ns (-80 version)  
 CAS access time:  
 20 ns  
 Cycle time:  
 110 ns (-60 version)  
 130 ns (-70 version)  
 150 ns (-80 version)
- Fast page mode cycle time  
 45 ns (-60 version)  
 45 ns (-70 version)  
 50 ns (-80 version)
- Single + 5 V ( $\pm 10\%$ ) supply with a built-in  $V_{bb}$  generator
- Low power dissipation  
 max. 605 mW active (-60 version)  
 max. 550 mW active (-70 version)  
 max. 468 mW active (-80 version)
- Standby power dissipation:  
 11 mW standby standby (TTL)  
 5.5 mW max.standby (CMOS)
- Output unlatched at cycle end allows two-dimensional chip selection
- Read, write, read-modify write, CAS-before-RAS refresh, RAS-only refresh, hidden refresh, fast page mode capability
- All inputs and outputs TTL-compatible
- 1024 refresh cycles / 16 ms
- Plastic Packages: P-SOJ-28-2 400 mil width

### Ordering Information

Type	Ordering Code	Package	Descriptions
HYB 514800BJ-60	Q67100-Q849	P-SOJ-28-2	DRAM (access time 60 ns)
HYB 514800BJ-70	Q67100-Q850	P-SOJ-28-2	DRAM (access time 70 ns)
HYB 514800BJ-80	Q67100-Q851	P-SOJ-28-2	DRAM (access time 80 ns)

The HYB 514800BJ is the new generation dynamic RAM organized as 512 288 words by 8-bit. The HYB 514800BJ utilizes CMOS silicon gate process as well as advances circuit techniques to provide wide operation margins, both internally and for the system user. Multiplexed address inputs permit the HYB 514800BJ to be packed in a standard plastic 400mil wide P-SOPJ-28 package. This package size provides high system bit densities and is compatible with commonly used automatic testing and insertion equipment. System oriented feature include single + 5 V ( $\pm 10\%$ ) power supply, direct interfacing with high performance logic device families such as Schottky TTL.

### Pin Definitions and Functions

A0-A8,A9R	Address Input
$\overline{\text{RAS}}$	Row Address Strobe
$\overline{\text{CAS}}$	Column Address Strobe
$\overline{\text{WRITE}}$	Read/Write Input
$\overline{\text{OE}}$	Output Enable
IO1 - IO8	Data Input/Output
N.C.	No Connection
$V_{\text{CC}}$	Power Supply (+ 5 V)
$V_{\text{SS}}$	Ground (0 V)

### Pin Configuration

(top view)

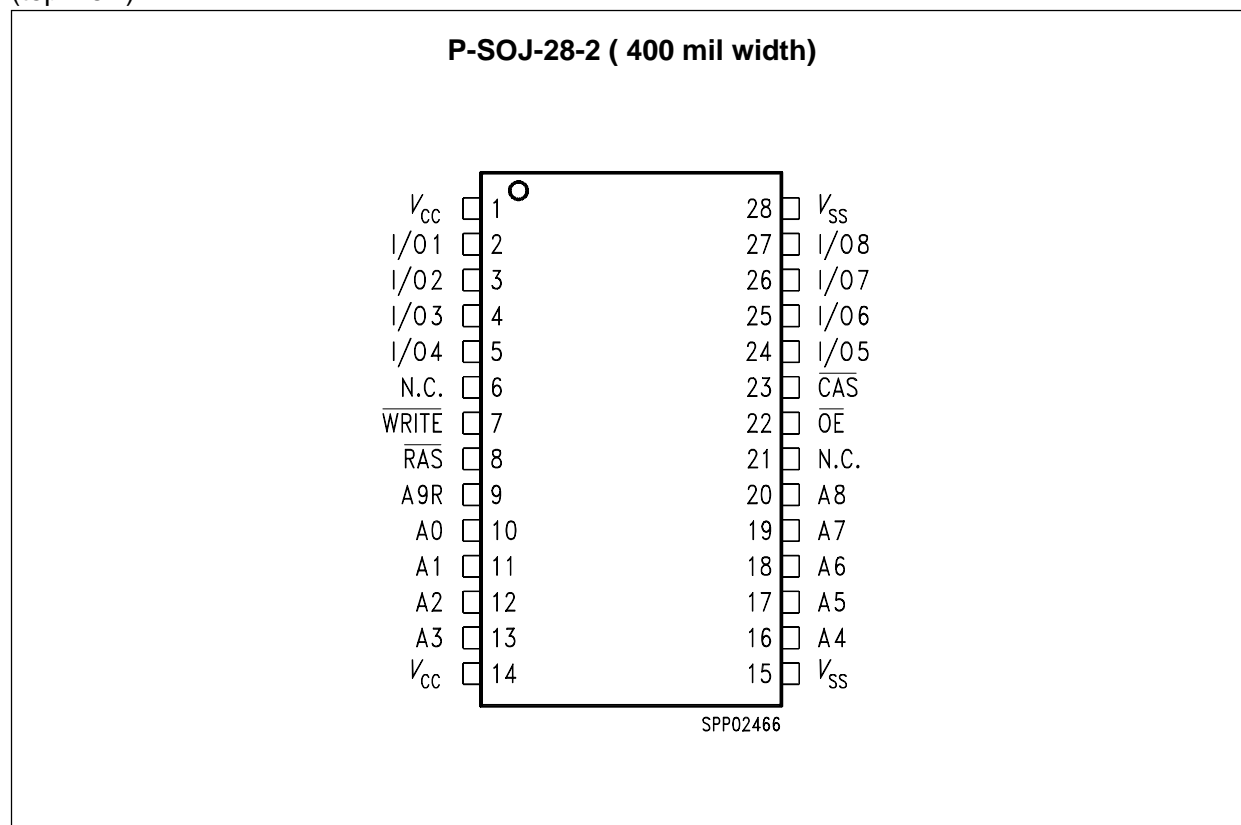

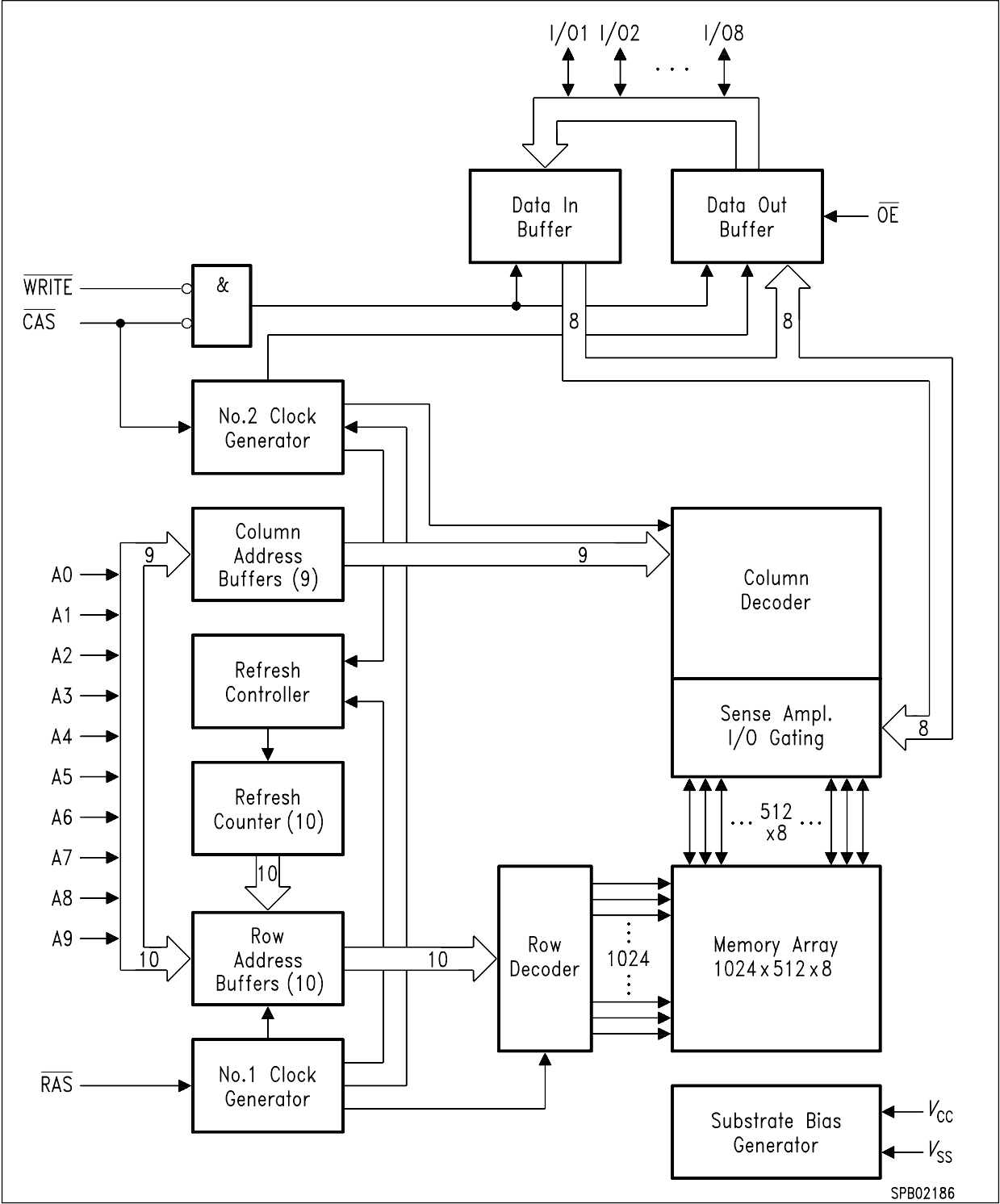

Block Diagram

### Absolute Maximum Ratings

Operating temperature range .....	0 to 70 °C
Storage temperature range.....	- 55 to + 150 °C
Soldering temperature .....	260 °C
Soldering time .....	10 s
Input/output voltage .....	- 1 to + 7 V
Power Supply voltage .....	- 1 to + 7 V
Data out current (short circuit) .....	50 mA

**Note:** Stresses above those listed under "Absolute Maximum Ratings" may cause permanent damage of the device. Exposure to absolute maximum rating conditions for extended periods may affect device reliability.

### DC Characteristics

$T_A = 0$  to  $70$  °C,  $V_{SS} = 0$  V,  $V_{CC} = 5$  V  $\pm$  10 %,  $t_T = 5$  ns

Parameter	Symbol	Limit Values		Unit	Test Condition
		min.	max.		
Input high voltage	$V_{ih}$	2.4	6.5	V	1)
Input low voltage	$V_{il}$	- 1.0	0.8	V	1)
Output high voltage ( $I_{OUT} = - 5$ mA)	$V_{oh}$	2.4	-	V	1)
Output low voltage ( $I_{OUT} = 4.2$ mA)	$V_{ol}$	-	0.4	V	1)
Input leakage current, any input ( $0$ V < $V_{in}$ < 7, all other input = 0 V)	$I_{I(L)}$	- 10	10	$\mu$ A	1)
Output leakage current (DO is disabled, $0 < V_{OUT} < V_{CC}$ )	$I_{O(L)}$	- 10	10	$\mu$ A	1)
Average $V_{CC}$ supply current -60 version -70 version -80 version	$I_{CC1}$	-	110 100 90	mA	2) 3)
Standby $V_{CC}$ supply current (RAS = CAS = $V_{ih}$ )	$I_{CC2}$	-	2	mA	-
Average $V_{CC}$ supply current during RAS-only refresh cycles -60 version -70 version -80 version	$I_{CC3}$	-	110 100 90	mA	2)
Average $V_{CC}$ supply current during fast page mode operation -60 version -70 version -80 version	$I_{CC4}$	-	70 60 50	mA	2) 3)

**DC Characteristics** (cont'd)

$T_A = 0$  to  $70$  °C,  $V_{SS} = 0$  V,  $V_{CC} = 5$  V  $\pm$  10 %,  $t_T = 5$  ns

Parameter	Symbol	Limit Values		Unit	Test Condition
		min.	max.		
Standby $V_{CC}$ supply current (RAS = CAS = $V_{CC} - 0.2$ V)	$I_{CC5}$	–	1	mA	1)
Average $V_{CC}$ supply current during CAS before RAS refresh mode	$I_{CC6}$			mA	2)
-60 version		–	110		
-70 version		–	100		
-80 version		–	90		

### AC Characteristics <sup>4)</sup>

$T_A = 0$  to  $70$  °C;  $V_{CC} = 5$  V  $\pm$  10 %;  $t_T = 5$  ns

Parameter	Symbol	Limit Values						Unit
		-60		-70		-80		
		min.	max.	min.	max.	min.	max.	
Random read or write time	$t_{RC}$	110	–	130	–	150	–	ns
Read-write cycle time	$t_{RWC}$	165	–	185	–	205	–	ns
Fast page mode cycle time	$t_{PC}$	45	–	45	–	50	–	ns
Fast page mode read/write cycle time	$t_{PRWC}$	100	–	100	–	105	–	ns
Access time from RAS <sup>6) 11)</sup>	$t_{RAC}$	–	60	–	70	–	80	ns
Access time from CAS <sup>6) 11)</sup>	$t_{CAC}$	–	20	–	20	–	20	ns
Access time from column address <sup>6) 12)</sup>	$t_{AA}$	–	30	–	35	–	40	ns
Access time from CAS precharge <sup>6)</sup>	$t_{CPA}$	–	40	–	40	–	45	ns
CAS to output in low-Z <sup>6)</sup>	$t_{CLZ}$	0	–	0	–	0	–	ns
Output buffer turn-off delay from CAS <sup>7)</sup>	$t_{OFF}$	0	20	0	20	0	20	ns
Transition time (rise and fall) <sup>5)</sup>	$t_T$	3	50	3	50	3	50	ns
RAS precharge time	$t_{RP}$	40	–	50	–	60	–	ns
RAS pulse width	$t_{RAS}$	60	10000	70	10000	80	10000	ns
RAS pulse width in fast page mode	$t_{RASP}$	60	200000	70	200000	80	200000	ns
CAS pulse width	$t_{CAS}$	20	10000	20	10000	20	10000	ns
RAS hold time	$t_{RSH}$	20	–	20	–	20	–	ns
CAS hold time	$t_{CSH}$	60	–	70	–	80	–	ns
RAS hold time from CAS precharge (Fast page mode)	$t_{RHCP}$	40	–	45	–	50	–	ns
CAS precharge to WRITE delay time (FPM read-modify-write)	$t_{CPWD}$	60	–	65	–	70	–	ns

### AC Characteristics (cont'd)<sup>4)</sup>

$T_A = 0$  to  $70$  °C;  $V_{CC} = 5$  V  $\pm$  10 %;  $t_T = 5$  ns

Parameter	Symbol	Limit Values						Unit
		-60		-70		-80		
		min.	max.	min.	max.	min.	max.	
RAS to CAS delay time <sup>11)</sup>	$t_{RCD}$	20	40	20	50	20	60	ns
RAS to column address delay time <sup>12)</sup>	$t_{RAD}$	15	30	15	35	15	40	ns
CAS to RAS precharge time	$t_{CRP}$	5	–	5	–	10	–	ns
CAS precharge time	$t_{CP}$	10	–	10	–	10	–	ns
Row address setup time	$t_{ASR}$	0	–	0	–	0	–	ns
Row address hold time	$t_{RAH}$	10	–	10	–	10	–	ns
Column address setup time	$t_{ASC}$	0	–	0	–	0	–	ns
Column address hold time	$t_{CAH}$	15	–	15	–	15	–	ns
Column address to RAS lead time	$t_{RAL}$	30	–	35	–	40	–	ns
Read command setup time	$t_{RCS}$	0	–	0	–	0	–	ns
Read command hold time <sup>8)</sup>	$t_{RCH}$	0	–	0	–	0	–	ns
Read command hold time ref. to RAS <sup>8)</sup>	$t_{RRH}$	0	–	0	–	0	–	ns
Write command hold time	$t_{WCH}$	10	–	15	–	15	–	ns
Write command hold time ref. to RAS	$t_{WCR}$	50	–	55	–	60	–	ns
Write command pulse width	$t_{WP}$	10	–	15	–	15	–	ns
Write command to RAS lead time	$t_{RWL}$	20	–	20	–	20	–	ns
Write command to CAS lead time	$t_{CWL}$	20	–	20	–	20	–	ns
Data setup time <sup>9)</sup>	$t_{DS}$	0	–	0	–	0	–	ns

### AC Characteristics (cont'd)<sup>4)</sup>

$T_A = 0$  to  $70$  °C;  $V_{CC} = 5$  V  $\pm$  10 %;  $t_T = 5$  ns

Parameter	Symbol	Limit Values						Unit
		-60		-70		-80		
		min.	max.	min.	max.	min.	max.	
Data hold time <sup>9)</sup>	$t_{DH}$	15	–	15	–	15	–	ns
Refresh period	$t_{REF}$	–	16	–	16	–	16	ms
Write command setup time <sup>10)</sup>	$t_{WCS}$	0	–	0	–	0	–	ns
CAS to WRITE delay time <sup>10)</sup>	$t_{CWD}$	50	–	50	–	50	–	ns
RAS to WRITE delay time <sup>10)</sup>	$t_{RWD}$	90	–	100	–	110	–	ns
Column address to WRITE delay time <sup>10)</sup>	$t_{AWD}$	60	–	65	–	70	–	ns
CAS setup time (CBR cycle)	$t_{CSR}$	5	–	5	–	5	–	ns
CAS hold time (CBR cycle)	$t_{CHR}$	15	–	15	–	15	–	ns
RAS to CAS precharge time	$t_{RPC}$	0	–	0	–	0	–	ns
CAS precharge time (CAS before RAS counter test cycle)	$t_{CPT}$	30	–	40	–	40	–	ns
Write to RAS precharge time (CBR cycle)	$t_{WRP}$	10	–	10	–	10	–	ns
Write to RAS hold time (CBR cycle)	$t_{WRH}$	10	–	10	–	10	–	ns
OE command hold time	$t_{OEH}$	20	–	20	–	20	–	ns
OE acces time	$t_{OEA}$	–	20	–	20	–	20	ns
RAS hold time referenced to OE	$t_{ROH}$	10	–	10	–	10	–	ns
Output buffer turn-off delay from OE	$t_{OEZ}$	0	20	0	20	0	20	ns
Data to CAS low delay <sup>14)</sup>	$t_{DZC}$	0	–	0	–	0	–	ns

### AC Characteristics (cont'd)<sup>4)</sup>

$T_A = 0$  to  $70$  °C;  $V_{CC} = 5$  V  $\pm$  10 %;  $t_T = 5$  ns

Parameter	Symbol	Limit Values						Unit
		-60		-70		-80		
		min.	max.	min.	max.	min.	max.	
Data to OE low delay <sup>14)</sup>	$t_{DZ0}$	0	–	0	–	0	–	ns
CAS high to data delay <sup>15)</sup>	$t_{CDD}$	20	–	20	–	20	–	ns
OE high to data delay <sup>15)</sup>	$t_{ODD}$	20	–	20	–	20	–	ns
CAS hold time after OE low	$t_{OECH}$	20	–	20	–	20	–	ns

### Capacitance

$T_A = 0$  to  $70$  °C;  $V_{CC} = 5$  V  $\pm$  10 %;  $f = 1$  MHz

Parameter	Symbol	Limit Values		Unit
		min.	max.	
Input capacitance (A0 to A9)	$C_{i1}$	–	5	pF
Input capacitance ( $\overline{RAS}$ , $\overline{CAS}$ , $\overline{WE}$ )	$C_{i2}$	–	7	pF
Output capacitance (IO1 to IO8)	$C_{io}$	–	7	pF

**Notes:**

- 1) All voltages are referenced to  $V_{SS}$ .
- 2)  $I_{CC1}$ ,  $I_{CC3}$ ,  $I_{CC4}$  and  $I_{CC6}$  depend on cycle rate.
- 3)  $I_{CC1}$ ,  $I_{CC4}$  depend on output loading.
- 4) An initial pause of 200  $\mu$ s is required after power-up followed by 8 RAS cycles of which at least one cycle has to be a refresh cycle, before proper device operation is achieved. In case of using the internal refresh counter, a minimum of 8 CAS-before-RAS initialization cycles instead of 8 RAS cycles are required.
- 5)  $V_{ih}$  (min.) and  $V_{il}$  (max.) are reference levels for measuring timing of input signals. Transition times are also measured between  $V_{ih}$  and  $V_{il}$ .
- 6) Measured with a load equivalent to 2 TTL loads and 100 pF.
- 7)  $t_{off}$  (max.),  $t_{OEZ}$  (max.) defines the time at which the output achieves the open-circuit conditions and are not referenced to output voltage levels.
- 8) Either  $t_{RCH}$  or  $t_{RRH}$  must be satisfied for a read cycle.
- 9) These parameters are references to the CAS leading edge in early write and to the WRITE leading edge in read-write cycles.
- 10)  $t_{WCS}$ ,  $t_{RWD}$ ,  $t_{CWD}$  and  $t_{AWD}$  are not restrictive operating parameters. They are included in the data sheet as electrical characteristics only.  
If  $t_{WCS} > t_{WCS}$  (min.), the cycle is an early write cycle and data out pin will remain open-circuit (high impedance) through the entire cycle; if  $t_{RWD} > t_{RWD}$  (min.),  $t_{CWD} > t_{CWD}$  (min.) and  $t_{AWD} > t_{AWD}$  (min.), the cycle is a read-write cycle and I/O will contain data read from the selected cell. If neither of the above sets of conditions is satisfied, the condition of I/O (at access time) is indeterminate.
- 11) Operation within the  $t_{RCD}$  (max.) limit ensure that  $t_{RAC}$  (max.) can be met.  $t_{RCD}$  (max.) is specified as a reference point only. If  $t_{RAD}$  is greater than the specified  $t_{RCD}$  (max.) limit, then access time is controlled by  $t_{CAC}$ .
- 12) Operation within the  $t_{RAD}$  (max.) limit ensured that  $t_{RAC}$  (max.) can be met.  $t_{RAD}$  (max.) is specified as a reference point only. If  $t_{RAD}$  is greater than the specified  $t_{RAD}$  (max.) limit, then access time is controlled by  $t_{AA}$ .
- 13) AC measurements assume  $t_T = 5$  ns.
- 14) Either  $t_{DZC}$  or  $t_{DZO}$  must be satisfied.
- 15) Either  $t_{CDD}$  or  $t_{ODD}$  must be satisfied.



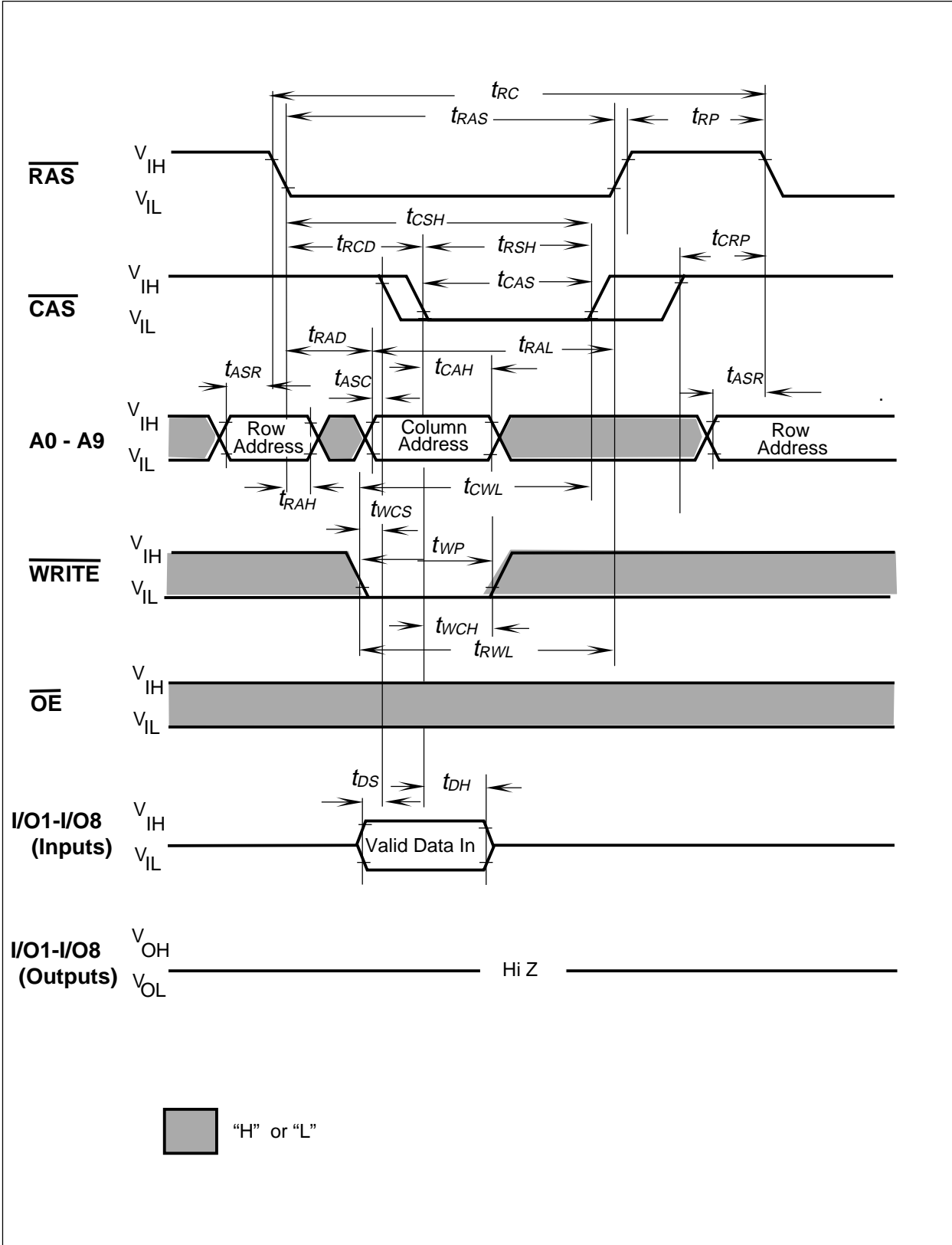

Write Cycle (Early Write)







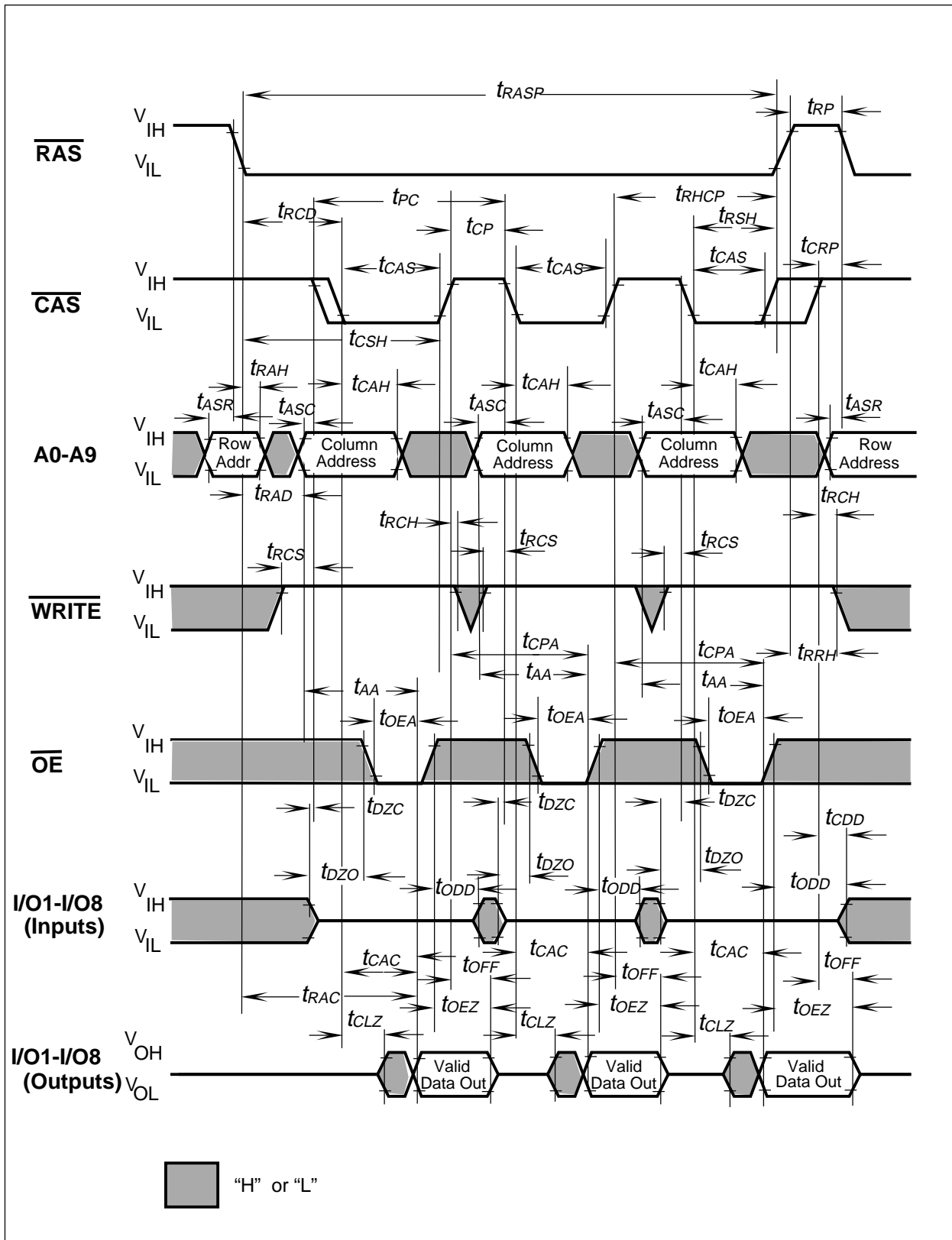

Fast Page Mode Read Cycle

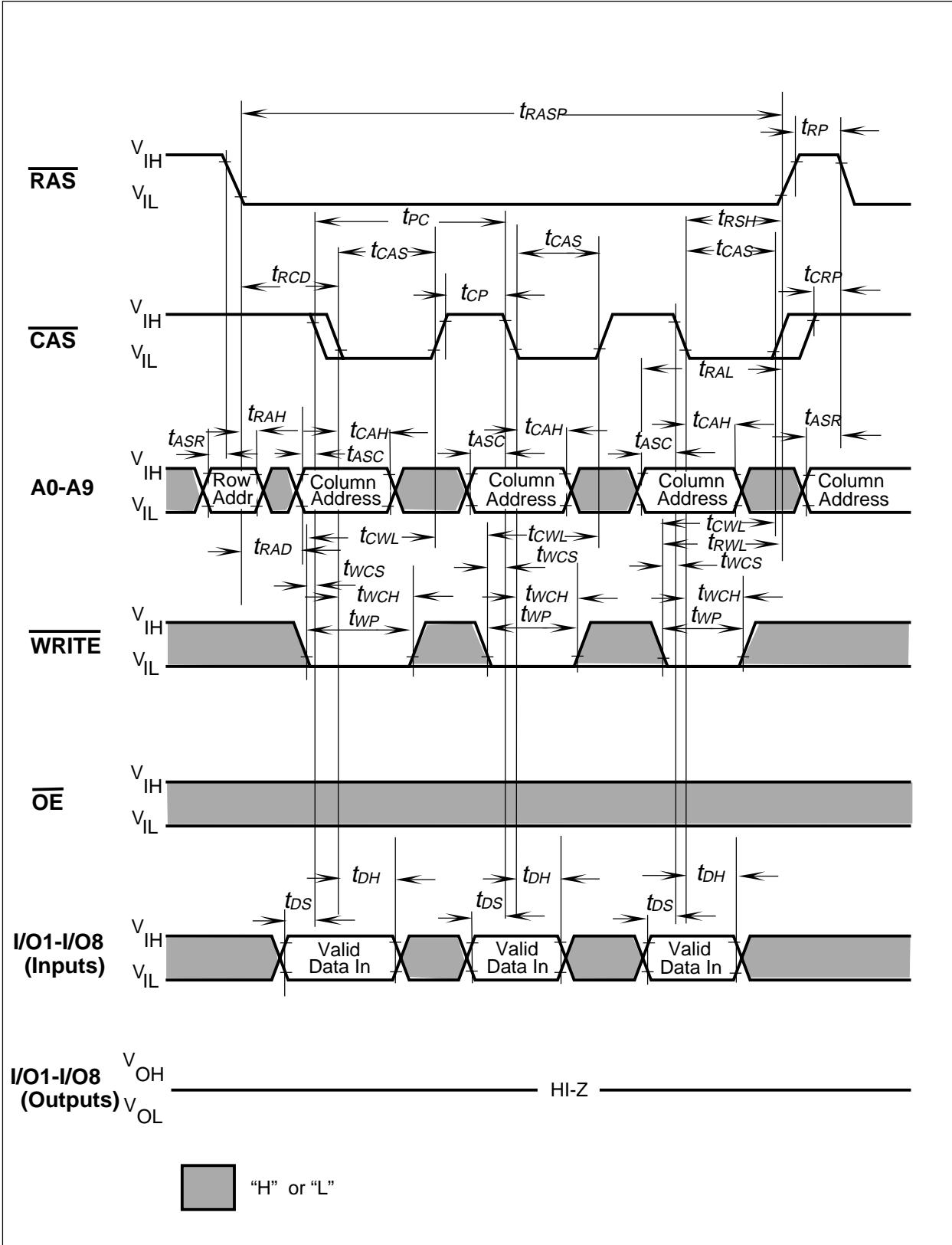

Fast Page Mode Early Write Cycle

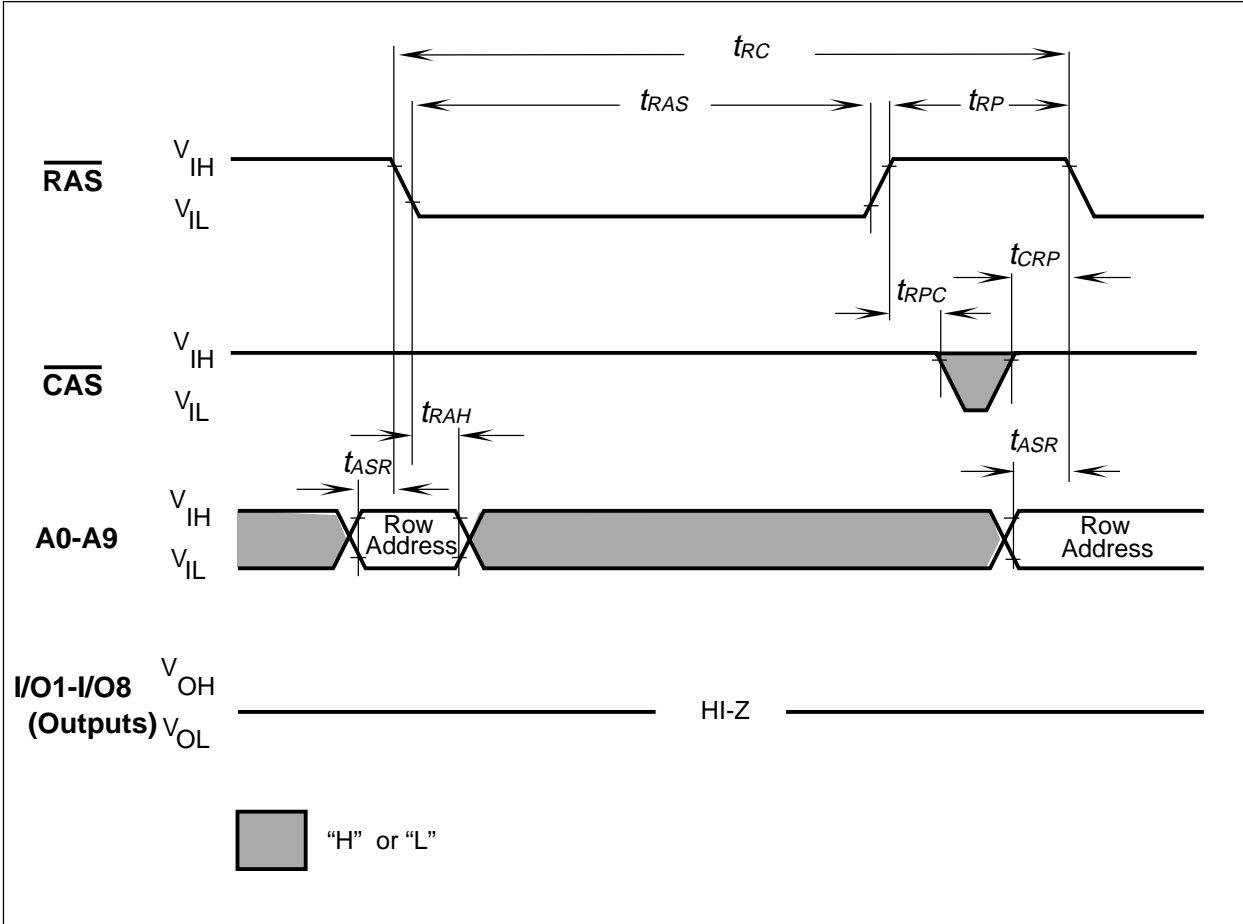

RAS-Only Refresh Cycle

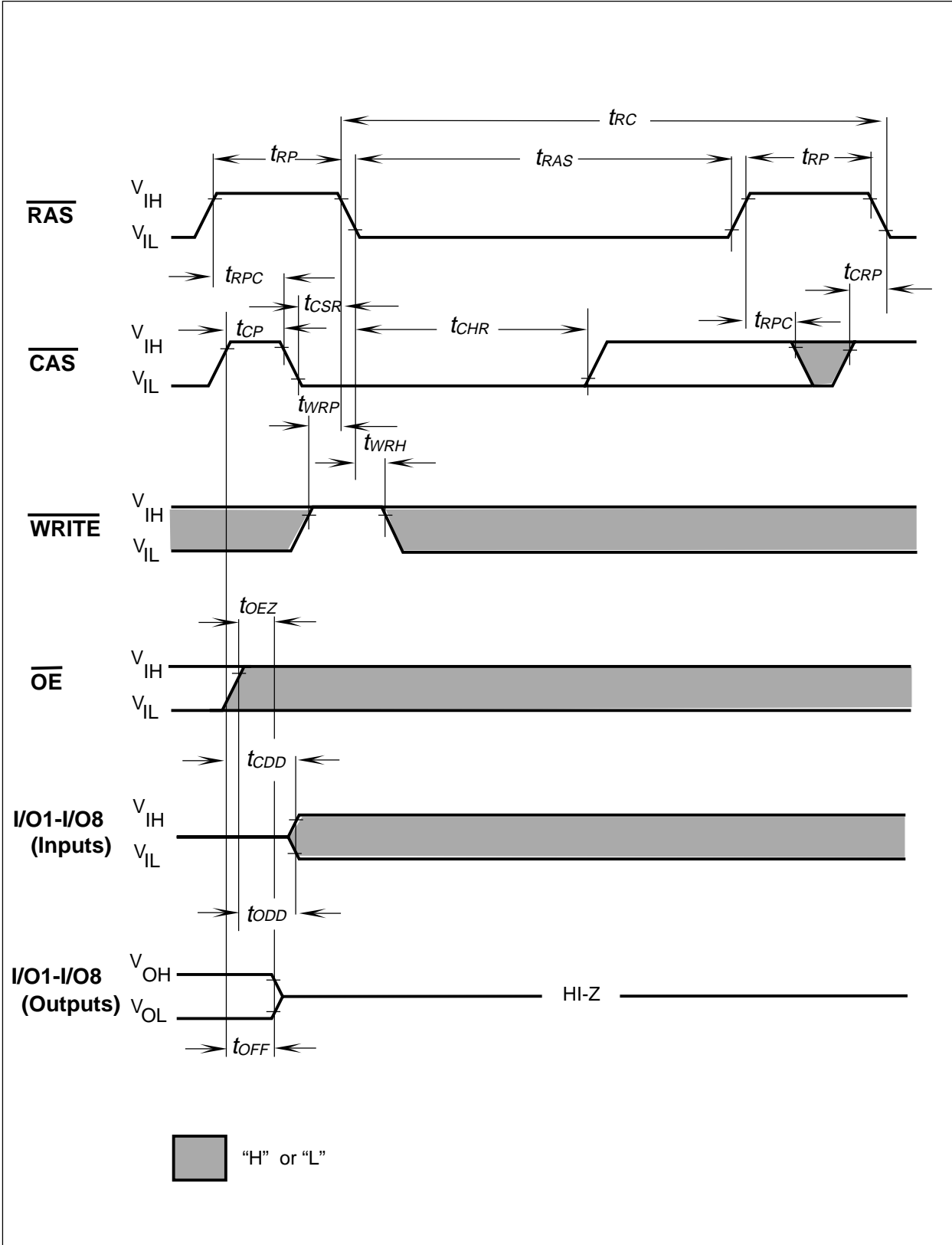

CAS-Before-RAS Refresh Cycle

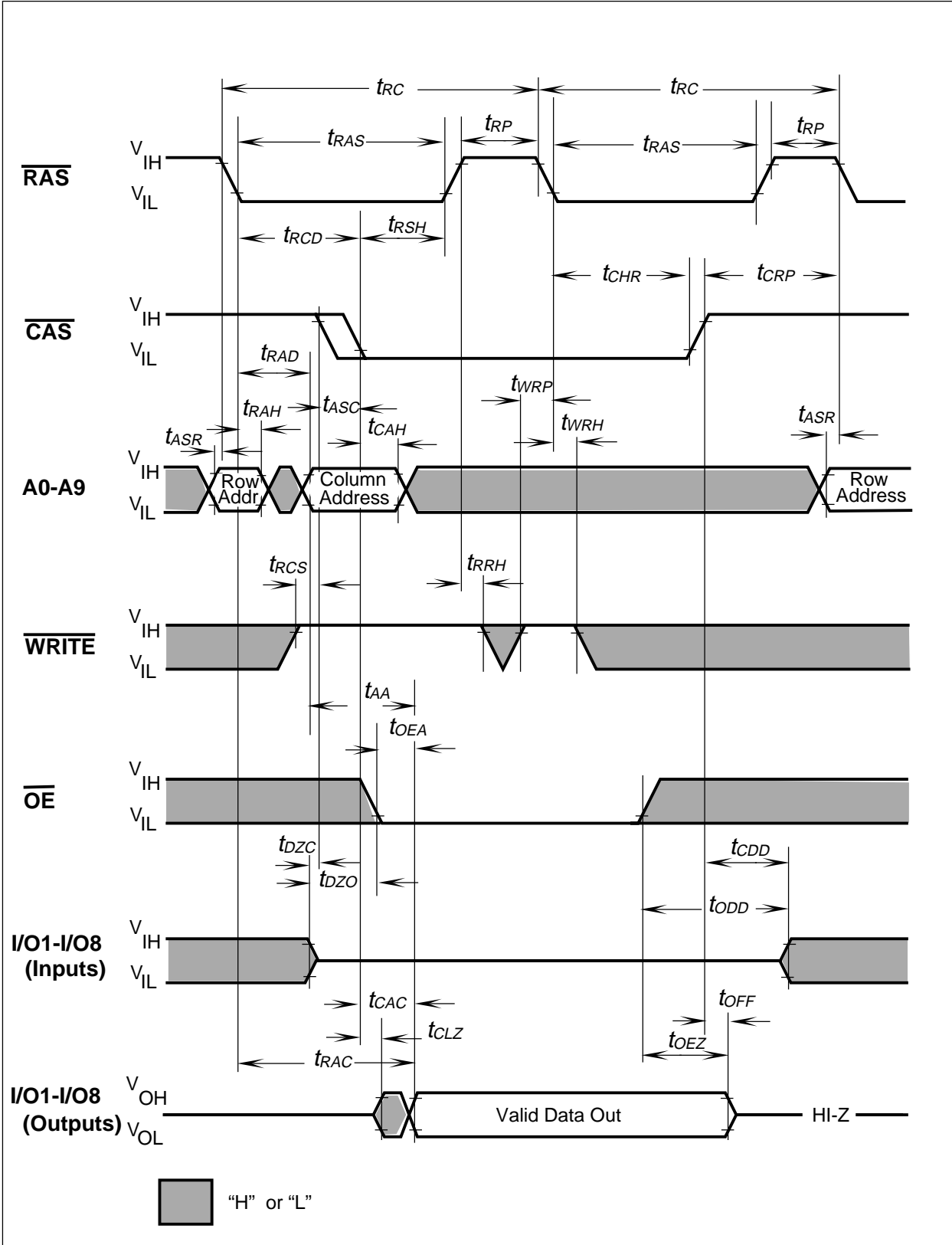

Hidden Refresh Cycle (Read)

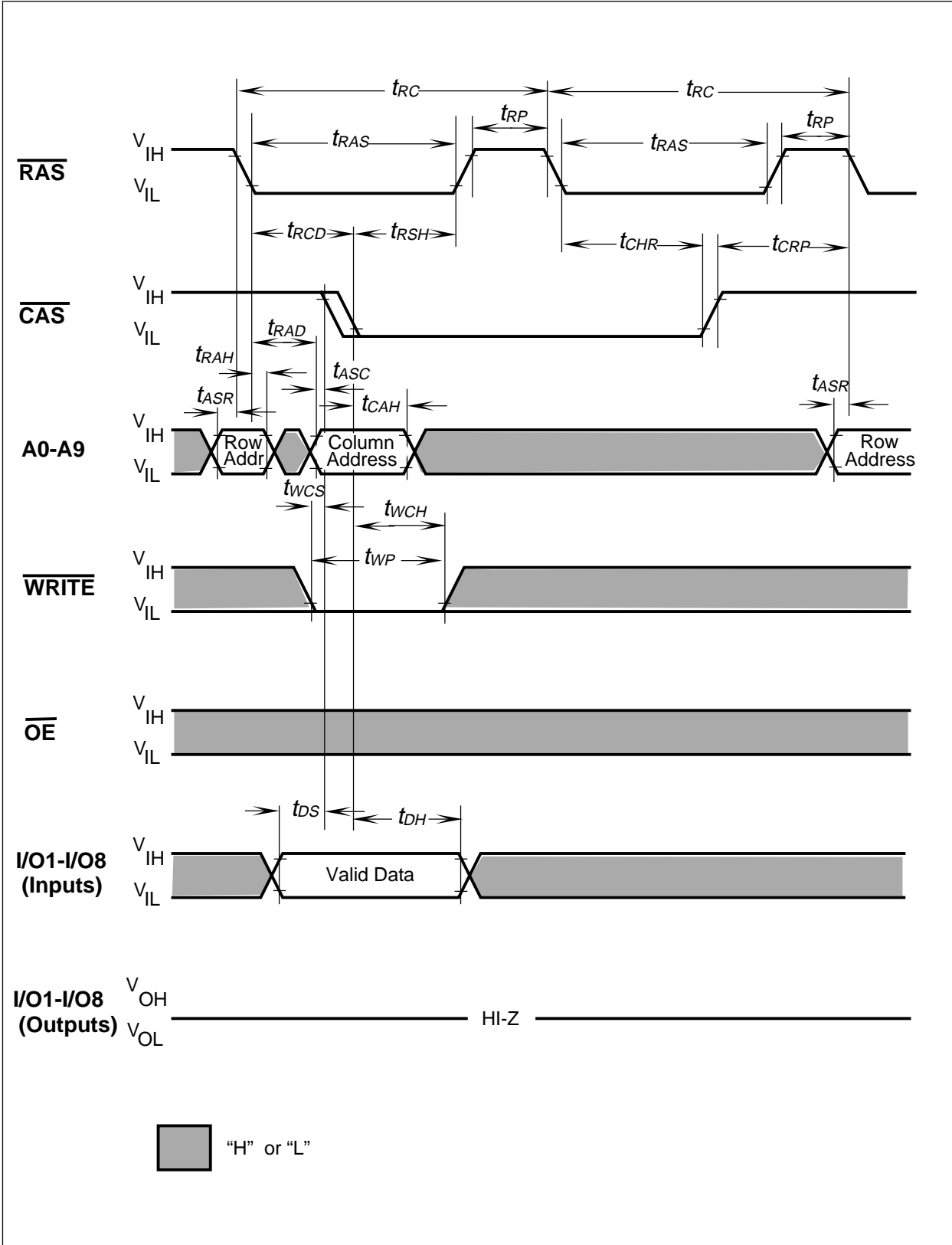

Hidden Refresh Cycle (Early Write)





LittleDiode supplies new, hard to find or obsolete electronic components and semiconductors all over the world.

With over two million different components listed you are sure to find the part you need.

Feel free to visit us today at our online store:

[LittleDiode.com](http://LittleDiode.com)

Looking forward to providing you with the best possible service.