

Am79C874

NetPHY™-1LP Low Power 10/100-TX/FX Ethernet Transceiver

DISTINCTIVE CHARACTERISTICS

- 10/100BASE-TX Ethernet PHY device with 100BASE-FX fiber optic support
- Typical power consumption of 0.3 W
- Sends/receives data reliably over cable lengths greater than 130 meters
- MII mode supports 100BASE-X and 10BASE-T
- 7-Wire (General Purpose Serial Interface (GPSI)) mode supports 10BASE-T
- Three PowerWise™ management modes (from 300 mW typical)
 - *Power down*: only management responds
Typical power = 3 mW
 - *Unplugged*: no cable, no receive clock
Typical power = 100 mW
 - *Idle wire*: no wire signal, no receiver power
Typical power = 285 mW; MAC saves over 100 mW
- Supports 1:1 or 1.25:1 transmit transformer
 - Using a 1.25:1 ratio saves 20% transmit power consumption
 - No external filters or chokes required
- Waveshaping – no external filter required
- Full and half-duplex operation with full-featured Auto-Negotiation function
- LED indicators: Link, TX activity, RX activity, Collision, 10 Mbps, 100 Mbps, Full or Half Duplex
- MDIO/MDC operates up to 25 MHz
- Automatic Polarity Detection
- Built-in loopback and test modes
- Single 3.3-V power supply with 5-V I/O tolerance
- 12 mm x 12 mm 80-pin TQFP package
- Support for industrial temperature (-40°C to +85°C)

GENERAL DESCRIPTION

The Am79C874 NetPHY-1LP device provides the physical (PHY) layer and transceiver functions for one 10/100 Mbps Ethernet port. It delivers the dual benefits of CMOS low power consumption and small package size. Operating at 3.3 V, it consumes only 0.3 W. Three power management modes provide options for even lower power consumption levels. The small 12x12 mm 80-pin PQL package conserves valuable board space on adapter cards, switch uplinks, and embedded Ethernet applications.

The NetPHY-1LP 10/100 Mbps Ethernet PHY device is IEEE 802.3 compliant. It can receive and transmit data reliably at over 130 meters. It includes on-chip input filtering and output waveshaping for unshielded twisted pair operation without requiring external filters or chokes. The NetPHY-1LP device can use 1:1 isolation transformers or 1.25:1 isolation transformers. 1.25:1 isolation transformers provide 20% lower transmit power consumption. A PECL interface is available for 100BASE-FX applications.

Interface to the Media Access Controller (MAC) layer is established via the standard Media Independent Interface (MII), a 5-bit symbol interface, or a 7-wire (GPSI)

interface. Auto-Negotiation determines the network speed and full or half-duplex operation. Automatic polarity correction is performed during Auto-Negotiation and during 10BASE-T signal reception.

Multiple LED pins are provided for front panel status feedback. One option is to use two bi-color LEDs to show when the device is in 100BASE-TX or 10BASE-T mode (by illuminating), Half or Full Duplex (by the color), and when data is being received (by blinking). Individual LEDs can indicate link detection, collision detection, and data being transmitted.

The NetPHY-1LP device needs only one external 25-MHz oscillator or crystal because it uses a dual-speed clock synthesizer to generate all other required clock domains. The receiver has an adaptive equalizer/DC restoration circuit for accurate clock/data recovery from the 100BASE-TX signal.

The NetPHY-1LP device is available in the commercial (0°C to +70°C) or industrial (-40°C to +85°C) temperature ranges. The industrial temperature range is well suited to environments, such as enclosures with restricted air flow or outdoor equipment.

BLOCK DIAGRAM

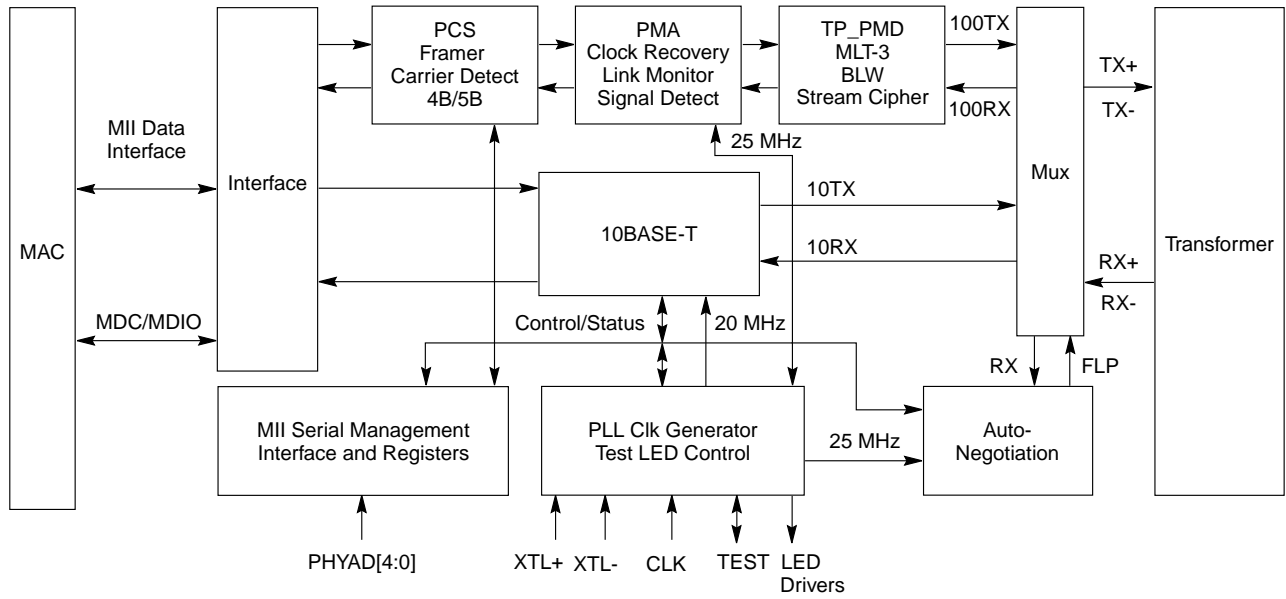

22235I-1

CONNECTION DIAGRAM

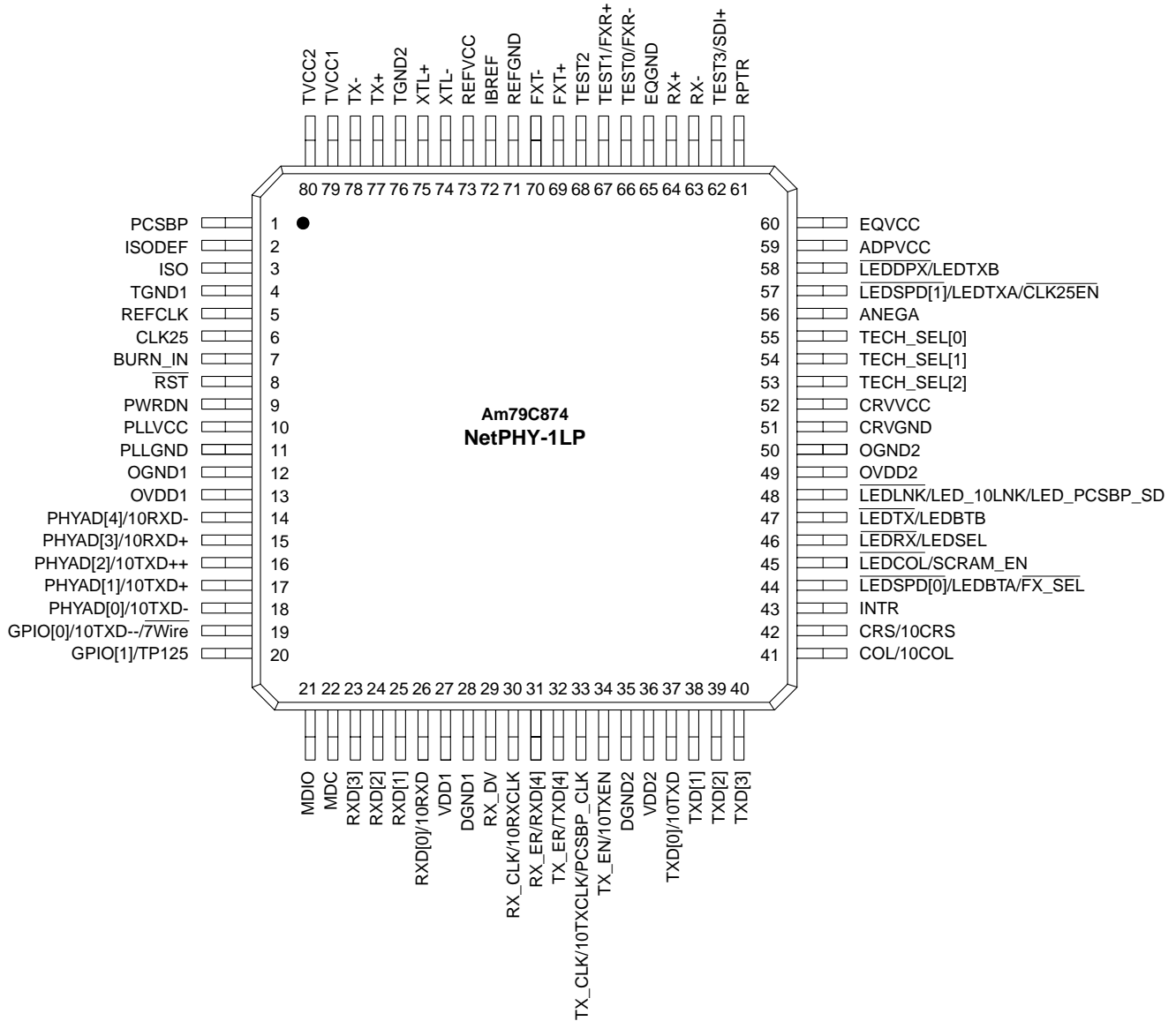

222351-2

ORDERING INFORMATION

Standard Products

AMD standard products are available in several packages and operating ranges. The order number (Valid Combination) is formed by a combination of the elements below.

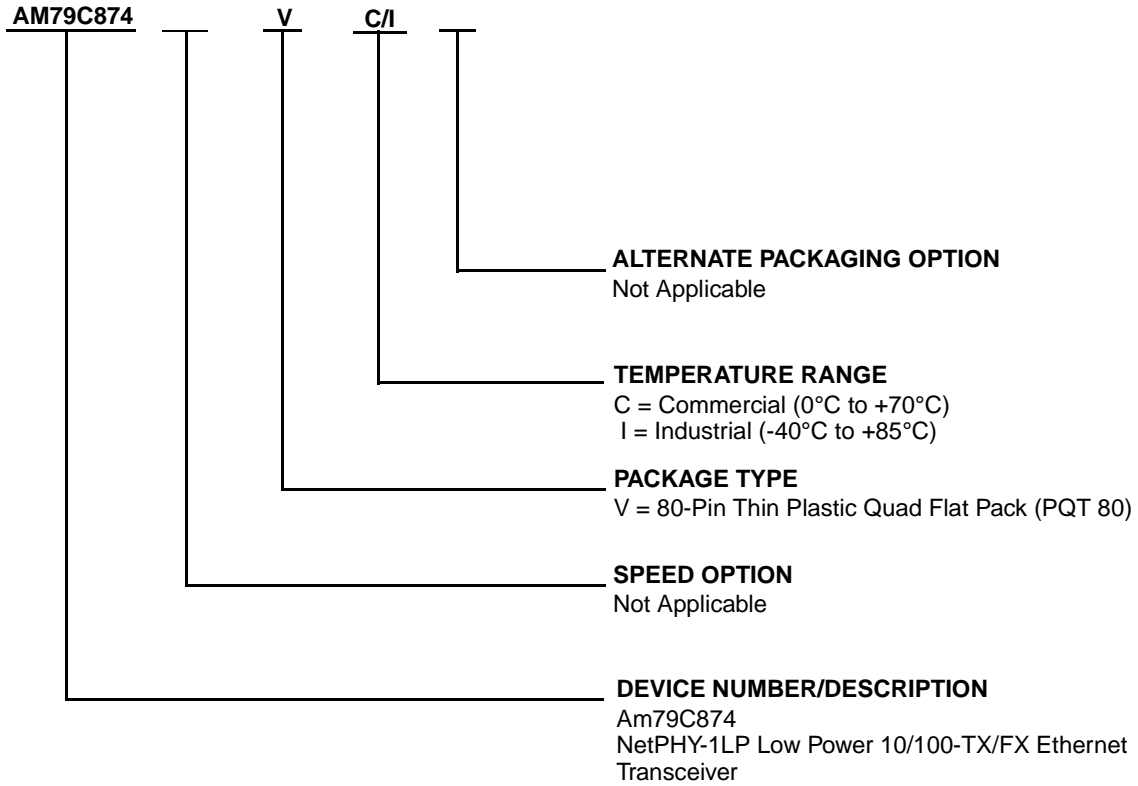

Valid Combinations	
AM79C874	VC
AM79C874	VI

Valid Combinations

Valid Combinations list configurations planned to be supported in volume for this device. Consult the local AMD sales office to confirm availability of specific valid combinations and to check on newly released combinations.

RELATED AMD PRODUCTS

Part No.	Description
Controllers	
Am79C90	CMOS Local Area Network Controller for Ethernet (C-LANCE™)
Integrated Controllers	
Am79C940	Media Access Controller for Ethernet (MACE™)
Am79C961A	PCnet™-ISA II Full Duplex Single-Chip Ethernet Controller for ISA Bus
Am79C965A	PCnet™-32 Single-Chip 32-Bit Ethernet Controller for 486 and VL Buses
Am79C970A	PCnet™-PCI II Full Duplex Single-Chip Ethernet Controller for PCI Local Bus
Am79C973/ Am79C975	PCnet™-FAST III Single-Chip 10/100 Mbps PCI Ethernet Controller with Integrated PHY
Am79C976	PCnet™-PRO 10/100 Mbps PCI Ethernet PCI Controller
Am79C978	PCnet™-Home Single-Chip 1/10 Mbps PCI Home Networking Controller
Physical Layer Devices (Single-Port)	
Am79C901	HomePHY™ Single-Chip 1/10 Mbps Home Networking PHY
Physical Layer Devices (Multi-Port)	
Am79C875	NetPHY™-4LP Low Power Quad10/100-TX/FX Ethernet Transceiver
Integrated Repeater/Hub Devices	
Am79C984A	Enhanced Integrated Multiport Repeater (eIMR™)
Am79C985	Enhanced Integrated Multiport Repeater Plus (eIMR+™)

TABLE OF CONTENTS

DISTINCTIVE CHARACTERISTICS	1
GENERAL DESCRIPTION	1
BLOCK DIAGRAM	2
CONNECTION DIAGRAM	3
ORDERING INFORMATION	4
Standard Products	4
RELATED AMD PRODUCTS	5
PIN DESIGNATIONS	9
PIN DESCRIPTIONS	10
Media Connections	10
MII/7-Wire (GPSI) Signals	10
Miscellaneous Functions	11
LED Port Pins	13
Bias	14
Power and Ground	14
FUNCTIONAL DESCRIPTION	15
Modes of Operation	15
MII Mode	15
7-Wire (GPSI) Mode	16
5B Symbol Mode	16
100BASE-X Block	16
Transmit Process	17
Receive Process	17
4B/5B Encoder/Decoder	18
Scrambler/Descrambler	18
Link Monitor	18
MLT-3	20
Adaptive Equalizer	20
Baseline Wander Compensation	20
Clock/Data Recovery	21
PLL Clock Synthesizer	21
10BASE-T Block	22
Twisted Pair Transmit Process	22
Twisted Pair Receive Process	22
Twisted Pair Interface Status	22
Collision Detect Function	22
Jabber Function	22
Reverse Polarity Detection and Correction	23
Auto-Negotiation and Miscellaneous Functions	23
Auto-Negotiation	23
Parallel Detection	23
Far-End Fault	24
SQE (Heartbeat)	24
Loopback Operation	24
Reset	25
LED Port Configuration	25
Power Savings Mechanisms	27
Selectable Transformer	27
Power Down	27
Unplugged	27
Idle Wire	27
PHY CONTROL AND MANAGEMENT BLOCK (PCM BLOCK)	28
Register Administration for 100BASE-X PHY Device	28
Description of the Methodology	28
Bad Management Frame Handling	29

REGISTER DESCRIPTIONS	29
Serial Management Registers	29
MII Management Control Register (Register 0)	30
MII Management Status Register (Register 1)	31
PHY Identifier 1 Register (Register 2).....	31
PHY Identifier 2 Register (Register 3).....	32
Auto-Negotiation Advertisement Register (Register 4)	32
Auto-Negotiation Link Partner Ability Register in Base Page Format (Register 5)	33
Auto-Negotiation Link Partner Ability Register in Next Page Format (Register 5)	33
Auto-Negotiation Expansion Register (Register 6)	34
Auto-Negotiation Next Page Advertisement Register (Register 7)	35
Reserved Registers (Registers 8-15, 20, 22, 25-31)	35
Miscellaneous Features Register (Register 16)	36
Interrupt Control/Status Register (Register 17).....	37
Diagnostic Register (Register 18)	37
Power/Loopback Register (Register 19).....	38
Mode Control Register (Register 21).....	39
Disconnect Counter Register (Register 23).....	40
Receive Error Counter Register (Register 24).....	40
ABSOLUTE MAXIMUM RATINGS	41
OPERATING RANGES	41
Commercial (C)	41
Industrial (I)	41
DC CHARACTERISTICS 41	
SWITCHING WAVEFORMS	43
Key to Switching Waveforms	43
SWITCHING CHARACTERISTICS	46
System Clock Signal	46
MLT-3 Signals.....	46
MII Management Signals	47
MII Signals	48
100 Mbps MII Transmit Timing	48
100 Mbps MII Receive Timing.....	50
10 Mbps MII Transmit Timing	52
10 Mbps MII Receive Timing.....	54
GPSI Signals	56
10 Mbps GPSI Receive Timing	56
10 Mbps GPSI Receive Timing	56
10 Mbps GPSI Collision Timing.....	57
10 Mbps GPSI Transmit Timing.....	58
10 Mbps GPSI Transmit Timing.....	58
PHYSICAL DIMENSIONS	59
PQT80 (measured in millimeters)	59
REVISION HISTORY	60

List of Figures

Figure 1.FXT \pm and FXR \pm Termination for 100BASE-FX	17
Figure 2.MLT-3 Waveform.....	20
Figure 3.TX \pm and RX \pm Termination for 100BASE-TX and 10BASE-T.....	21
Figure 5.Standard LED Configuration	26
Figure 6.Advanced LED Configuration	27
Figure 7.PHY Management Read and Write Operations.....	28
Figure 8.MLT-3 Receive Input	43
Figure 9.MLT-3 and 10BASE-T Test Load with 1:1 Transformer Ratio.....	44
Figure 10.MLT-3 and 10BASE-T Test Load with 1.25:1 Transformer Ratio	44
Figure 11.Near-End 100BASE-TX Waveform	45
Figure 12.10BASE-T Waveform With 1:1 Transformer Ratio.....	45

Figure 13.PECL Test Loads.	45
Figure 14.Clock Signal.	46
Figure 15.MLT-3 Test Waveform.	46
Figure 16.Management Bus Transmit Timing	47
Figure 17.Management Bus Receive Timing.	47
Figure 18.100 Mbps MII Transmit Start of Packet Timing	48
Figure 19.100 Mbps Transmit End of Packet Timing	49
Figure 20.100 Mbps MII Receive Start of Packet Timing.	50
Figure 21.100 Mbps MII Receive End of Packet Timing	51
Figure 22.10 Mbps MII Transmit Start of Packet Timing	52
Figure 23.10 Mbps MII Transmit End of Packet Timing	53
Figure 24.10 Mbps MII Receive Start of Packet Timing.	54
Figure 25.10 Mbps MII Receive End of Packet Timing	55
Figure 26.GPSI Receive Timing - Start of Reception	56
Figure 27.GPSI Receive Timing - End of Reception (Last Bit = 0)	56
Figure 28.GPSI Receive Timing - End of Reception (Last Bit = 1)	57
Figure 29.GPSI Collision Timing	57
Figure 30.GPSI Transmit Timing - Start of Transmission.	58
Figure 31.GPSI Transmit 10TXCLK and 10TXD Timing	58
Figure 32.Test Load for 10RXD, 10CRS, 10RXCLK, 10TXCLK and 10COL.	58

List of Tables

Table 1.MII Pins That Relate to 10 Mbps 7-Wire (GPSI) Mode	16
Table 2.Code-Group Mapping	19
Table 3.Speed and Duplex Capabilities	24
Table 4.Standard LED Selections	25
Table 5.Advanced LED Selections	26
Table 6.Clause 22 Management Frame Format	28
Table 7.PHY Address Setting Frame Structure	28
Table 8.Register Summary	29
Table 9.Legend for Register Table	29
Table 10.MII Management Control Register (Register 0)	30
Table 11.MII Management Status Register (Register 1)	31
Table 12.PHY Identifier 1 Register (Register 2)	31
Table 13.PHY Identifier 2 Register (Register 3)	32
Table 14.Auto-Negotiation Advertisement Register (Register 4)	32
Table 15.Auto-Negotiation Link Partner Ability Register in Base Page Format (Register 5)	33
Table 16.Auto-Negotiation Lnk Partner Ability Register in Next Page Format (Register 5)	33
Table 17.Auto-Negotiation Expansion Register (Register 6)	34
Table 18.Auto-Negotiation Next Page Advertisement Register (Register 7)	35
Table 19.Miscellaneous Features Register (Register 16)	36
Table 20.Interrupt Control/Status Register (Register 17)	37
Table 21.Diagnostic Register (Register 18)	37
Table 22.Power/Loopback Register (Register 19)	38
Table 23.Mode Control Register (Register 21)	39
Table 24.Disconnect Counter (Register 23)	40
Table 25.Receive Error Counter Register (Register 24)	40

PIN DESIGNATIONS

Listed by Pin Number

Pin No.	Pin Name	Pin No.	Pin Name	Pin No.	Pin Name	Pin No.	Pin Name
1	PCSBP	21	MDIO	41	COL/10COL	61	RPTR
2	ISODEF	22	MDC	42	CRS/10CRS	62	TEST3/SDI+
3	ISO	23	RXD[3]	43	INTR	63	RX-
4	TGND1	24	RXD[2]	44	LEDSPD[0]/ LEDBTA/FX_SEL	64	RX+
5	REFCLK	25	RXD[1]	45	LEDCOL/ SCRAM_EN	65	EQGND
6	CLK25	26	RXD[0]/10RXD	46	LEDRX/LEDSEL	66	TEST0/FXR-
7	BURN_IN	27	VDD1	47	LEDTX/LEDBTB	67	TEST1/FXR+
8	RST	28	DGND1	48	LEDLNK/ LED_10LNK/ LED_PCSBP_SD	68	TEST2
9	PWRDN	29	RX_DV	49	OVDD2	69	FXT+
10	PLLVCC	30	RX_CLK/10RXCLK	50	OGND2	70	FXT-
11	PLLGND	31	RX_ER/RXD[4]	51	CRVGND	71	REFGND
12	OGND1	32	TX_ER/TXD[4]	52	CRVVCC	72	IBREF
13	OVDD1	33	TX_CLK/10TXCLK/ PCSBP_CLK	53	TECH_SEL[2]	73	REFVCC
14	PHYAD[4]/10RXD-	34	TX_EN/10TXEN	54	TECH_SEL[1]	74	XTL-
15	PHYAD[3]/10RXD+	35	DGND2	55	TECH_SEL[0]	75	XTL+
16	PHYAD[2]/10TXD++	36	VDD2	56	ANEGA	76	TGND2
17	PHYAD[1]/10TXD+	37	TXD[0]/10TXD	57	LEDSPD[1]/ LEDTXA/CLK25EN	77	TX+
18	PHYAD[0]/10TXD-	38	TXD[1]	58	LEDDPX/LEDTXB	78	TX-
19	GPIO[0]/10TXD-/ 7Wire	39	TXD[2]	59	ADPVCC	79	TVCC1
20	GPIO[1]/TP125	40	TXD[3]	60	EQVCC	80	TVCC2

PIN DESCRIPTIONS

The following table describes terms used in the pin descriptions.

Term	Description
Input	Digital input to the PHY
Analog Input	Analog input to the PHY
Output	Digital output from the PHY
Analog Output	Analog output from the PHY
High Impedance	Tri-state capable output from the PHY
Pull-Up	PHY has internal pull-up resistor. NC=HIGH
Pull-Down	PHY has internal pull-down resistor. NC=LOW

Media Connections

TX±

Transmitter Outputs

Analog Output

The TX± pins are the differential transmit output pair. The TX± pins transmit 10BASE-T or MLT-3 signals depending on the state of the link of the port.

RX±

Receiver Input

Analog Input

The RX± pins are the differential receive input pair. The RX± pins can receive 10BASE-T or MLT-3 signals depending on the state of the link of the port.

FXT±

FX Transmit

Analog Output

These pins are not connected in 10/100BASE-TX mode.

When $\overline{\text{FX_SEL}}$ (Pin 44) is pulled low, these pins become the ECL level transmit output for 100BASE-FX.

TEST0/FXR-

Test Output/FX Receive

-Analog Output/Input

When BURN_IN (Pin 7) is pulled high, this pin serves as a test mode output monitor pin.

When $\overline{\text{FX_SEL}}$ (Pin 44) is pulled low, this pin becomes an ECL level negative receive input for 100BASE-FX.

This pin can be left unconnected when the device is operating in 100BASE-TX or 10BASE-T mode.

TEST1/FXR+

Test Output/FX Receive

+Analog Output/Input

When BURN_IN (Pin 7) is pulled high, this pin serves as a test mode output monitor pin.

When $\overline{\text{FX_SEL}}$ (Pin 44) is pulled low, this pin becomes an ECL level positive receive input for 100BASE-FX.

This pin can be left unconnected when the device is operating in 100BASE-TX or 10BASE-T mode.

TEST3/SDI+

FX Transceiver Signal Detect Analog Output/Input

When BURN_IN (Pin 7) is pulled high, this pin serves as a test mode output monitor pin.

This pin is not connected in 10/100BASE-TX mode.

When $\overline{\text{FX_SEL}}$ (Pin 44) is pulled low, this pin becomes the Signal Detect input from the Fiber-Optic transceiver. When the signal quality is good, the SDI+ pin should be driven high.

MII/7-Wire (GPSI) Signals

RXD[3:0]

MII Receive Data

Output, High Impedance

The data is synchronous with RX_CLK when RX_DV is active. When the 7-wire 10BASE-T interface operation is enabled (GPIO[0]= HIGH), RXD[0] will serve as the 10 MHz serial data output.

RX_DV

Receive Data Valid

Output, High Impedance

RX_DV is asserted when the NetPHY-1LP device is presenting recovered nibbles on RXD[3:0]. This includes the preamble through the last nibble of the data stream on RXD[3:0]. In 100BASE-X mode, the /J/K/ is considered part of the preamble; thus RX_DV is asserted when /J/K/ is detected. In 10BASE-T mode, RX_DV is asserted (and data is presented on RXD[3:0]) when the device detects valid preamble bits. RX_DV is synchronized to RX_CLK.

RX_CLK/10RXCLK

Receive Clock

Output, High Impedance

A continuous clock (which is active while LINK is established) provides the timing reference for RX_DV, RX_ER, and RXD[3:0] signals. It is 25 MHz in 100BASE-TX/FX and 2.5 MHz in 10BASE-T. To further reduce power consumption of the overall system, the device provides an optional mode enabled through MII Register 16, bit 0 in which RX_CLK is held inactive (low) when no data is received. If RX_CLK is needed when LINK is not established, the NetPHY-1LP must be placed into digital loopback or force the link via register 21, bits 13 or 14.

When 7-wire 10BASE-T mode is enabled, this pin will provide a 10 MHz clock. RX_CLK is high impedance when the ISO pin is enabled

RX_ER/RXD[4]

Receive Error

Output, High Impedance

When RX_ER is active high, it indicates an error has been detected during frame reception.

This pin becomes the highest-order bit of the receive 5-bit code group in PCS bypass (PCSBP=HIGH) mode. This output is ignored in 10BASE-T operation.

TX_ER/TXD[4]**Transmit Error** **Input**

When TX_ER is asserted, it will cause the 4B/5B encoding process to substitute the transmit error code-group /H/ for the encoded data word.

This pin becomes the higher-order bit of the transmit 5-bit code group in PCS bypass (PCSBP=HIGH) mode. This input is ignored in the 10BASE-T operation.

TX_CLK/10TXCLK/PCSBPCLK**Transmit Clock** **Output, High Impedance**

A free-running clock which provides timing reference for TX_EN, TX_ER, and TXD[3:0] signals. It is 25 MHz in 100BASE-TX/FX and 2.5 MHz in 10BASE-T.

When 7-wire GPSI mode is enabled, this pin will provide a 10 MHz transmit clock for 10BASE-T operation. When the cable is unplugged, the 10TXCLK ceases operation.

When working in PCSBP mode, this pin will provide a 25 MHz clock for 100BASE-TX operation, and 20 MHz clock for 10BASE-T operation. TX_CLK is high impedance when the ISO pin is enabled.

TX_EN/10TXEN**Transmit Enable** **Input**

The TX_EN pin is asserted by the MAC to indicate that data is present on TXD[3:0].

When 7-wire 10BASE-T mode is enabled, this pin is the transmit enable signal.

TXD[3:1]**Transmit Data** **Input**

The MAC will source TXD[3:1] to the PHY. The data will be synchronous with TX_CLK when TX_EN is asserted. The PHY will clock in the data based on the rising edge of TX_CLK.

TXD[0]/10TXD**Transmit Data[0]/10 Mbps Transmit Data** **Input**

The MAC will source TXD[0] to the PHY. The data will be synchronous with TX_CLK when TX_EN is asserted. The PHY will clock in the data based on the rising edge TX_CLK.

When 7-wire 10BASE-T mode is enabled, this pin will transmit serial data.

COL/10COL**Collision** **Output, High Impedance**

COL is asserted high when a collision is detected on the media. COL is also used for the SQE test function in 10BASE-T mode.

10COL is asserted high when a collision is detected during 7-wire interface mode.

CRS/10CRS**Carrier Sense** **Output, High Impedance**

CRS is asserted high when twisted pair media is non-idle. This signal is used for both 10BASE-T and 100BASE-X. In full duplex mode, CRS responds only to RX activity. In half duplex mode, CRS responds to both RX and TX activity.

10CRS is used as the carrier sense output for the 7-wire interface mode.

Miscellaneous Functions**PCSBP****PCS Bypass** **Input, Pull-Down**

The 100BASE-TX PCS as well as scrambler/descrambler will be bypassed when PCSBP is pulled high via a 10 k Ω resistor. TX_ER will become TXD[4] and RX_ER will become RXD[4].

In 10 Mbps PCS bypass mode, the MII signals are not valid. The signals that interface to the MAC (i.e., DECPC 21143) are located on pins 14 to 19. The signals are defined as follows:

- 10RXD \pm are the differential receive outputs to the MAC.
- 10TXD \pm are the differential transmit inputs from the MAC.
- 10TXD++/10TXD-- are the differential pre-emphasis transmit outputs from the MAC.

When left unconnected, the device operates in MII or GPSI mode.

ISODEF**Isolate Default** **Input, Pull-Down**

This pin is used when multiple PHYs are connected to a single MAC. When it is pulled high via a 10 k Ω resistor, the MII interface will be high impedance. The status of this pin will be latched into MII Register 0, bit 10 after reset.

When this pin is left unconnected, the default condition of the MII output pins are not in the high impedance state.

ISO**Isolate** **Input, Pull-Down**

The MII output pins will become high impedance when ISO is pulled high via a 10 k Ω resistor. However, the MII input pins will still respond to data. This allows multiple PHYs to be attached to the same MII interface. The same isolate condition can also be achieved by asserting MII Register 0, bit 10. In repeater mode, ISO will not tri-state the CRS pin.

When this pin is left unconnected, the MII output pins are not in the high impedance state.

REFCLK**Clock Input****Input, Pull-Down**

This pin connects to a 25-MHz ± 50 ppm clock source with a 40% to 60% duty cycle. When a crystal input is used, this pin should be pulled low via a 1 k Ω resistor.

XTL \pm **Crystal Inputs****Analog Input**

These pins should be connected to a 25-MHz crystal. The crystal should be parallel resonant and have a frequency stability of ± 100 ppm and a frequency tolerance of ± 50 ppm. REFCLK (Pin 5) should be pulled low when the crystal is used as a clock source.

These pins may be left unconnected when REFCLK is used as a clock source.

CLK25**25 MHz Clock****Output**

When the $\overline{\text{CLK25EN}}$ pin is pulled low, the CLK25 pin provides a continuous 25 MHz clock to the MAC.

BURN_IN**Test Enable****Input, Pull-Down**

When pulled high via a 10 k Ω resistor, this pin forces the NetPHY-1LP device into Burn-in mode for reliability assurance control. When left unconnected the device operates normally.

TEST2**Test Output****Analog Output**

When BURN_IN (pin 7) is pulled high, this pin serves as a test mode output monitor pin. TEST2 can be left unconnected when the device is operating.

RST**Reset****Input, Pull-Up**

A LOW input forces the NetPHY-1LP device to a known reset state. The chip can also be reset through internal power-on-reset or MII Register 0, bit 15.

PWRDN**Power Down****Input, Pull-Down**

If this pin is pulled high via a 10 k Ω resistor on the rising edge of reset, the device will power down the analog modules and reset the digital circuits. However, the device will still respond to MDC/MDIO data. The same power-down state can also be achieved through the MII Register 0, bit 11. However, the device will respond actively on the PWRDN pin even when bit 11 is not set.

When left unconnected, the device operates normally.

PHYAD[4:0]**PHY Address****Input/Output, Pull-Up**

These pins allow 32 configurable PHY addresses. The PHYAD will also determine the scramble seed, which helps to reduce EMI when there are multiple ports switching at the same time (repeater/switch applica-

tions). Each pin should either be pulled low via a 1 k Ω – 4.7 k Ω resistor (set bit to zero) or left unconnected (set bit to 1) in order to achieve the desired PHY address. New address changes take effect after a reset has been issued, or at power up.

In PCS bypass mode, PHYAD[4:0] and GPIO[1:0] serves as 10BASE-T serial input and output.

Note: In GPSI mode, the PHYAD pins must be set to addresses other than 00h.

GPIO[0]/10TXD--7Wire**General Purpose I/O 0****Input/Output, Pull-Up**

If this pin is pulled low via a 10 k Ω resistor, on the rising edge of reset, the device will operate in 10BASE-T 7-wire (GPSI) mode. If this pin is left unconnected during the rising edge of reset, the device will operate in standard MII mode.

After the reset operation has completed, this pin can function as an input or an output (dependent on the value of GPIO[0] DIR (MII Register 16, bit 6). If MII Register 16, bit 6 is set HIGH, GPIO[0] is an input. The input value on the GPIO[0] pin will be reflected in MII Register 16, bit 7 – GPIO[0] Data. If MII Register 16, bit 6 is set LOW, GPIO[0] is an output. The value of MII Register 16, bit 7 will be reflected on the GPIO[0] output pin.

GPIO[1]/TP125**General Purpose I/O 1****Input/Output, Pull-Down**

If this pin is pulled high via a 10 k Ω resistor, on the rising edge of reset, the device will be enabled for use with a 1.25:1 transmit ratio transformer. If this pin is left unconnected during the rising edge of reset, the device will be enabled for use with a 1:1 transmit ratio transformer.

After the reset operation has completed, this pin can function as an input or an output (dependent on the value of GPIO[1] DIR – MII Register 16, bit 8). If MII Register 16, bit 8 is set HIGH, GPIO[1] is an input. The input value on the GPIO[1] pin will be reflected in MII Register 16, bit 9 – GPIO[1] Data. If MII Register 16, bit 8 is set LOW, GPIO[1] is an output. The value of MII Register 16, bit 9 will be reflected on the GPIO[1] output pin.

MDIO**Management Data Input/Output****Pull-Down**

This pin is a bidirectional data interface used by the MAC to access management registers within the NetPHY-1LP device. This pin has an internal pull-down, therefore, it requires a 1.5 k Ω pull-up resistor as specified in IEEE 802.3 when interfaced with a MAC. This pin can be left unconnected when management is not used.

MDC**Management Data Clock** **Input**

This clock is sourced by the MAC and is used to synchronize MDIO data. When management is not used, this pin should be tied to ground.

INTR**Interrupt** **Output, High Impedance**

This pin is used to signal an interrupt to the MAC. The pin will be forced high or low (normally high impedance) to signal an interrupt depending upon the value of the INTR_LEVEL bit, MII Register 16, bit 14. The events which trigger an interrupt can be programmed via the Interrupt Control Register (Register 17).

TECH_SEL[2:0]**Technology Select** **Input, Pull-Up**

The Technology Select pins, in conjunction with the ANEGA pin, set the speed and duplex configurations for the device on the rising edge of reset. These capabilities are reflected in MII Register 1 and MII Register 4. Table 3 lists the possible configurations for the device. If the input is listed as LOW, the pin should be pulled to ground via a 10 k Ω resistor on the rising edge of reset. If the input is listed as HIGH, the pin can be left unconnected.

***Note:** By using resistors to hard wire the TECH_SEL[2:0] pins and the ANEGA pin, using the MDC/MDIO management interface pins becomes optional. The device's speed, duplex, and auto-negotiation capabilities are set via hardware. If the management interface is used, the registers cannot be set to a higher capability than the hard-wired setting. The highest capabilities are Full Duplex, 100 Mbps, and Auto-Negotiation enabled.*

ANEGA**Auto-Negotiation Ability** **Input, Pull-Up**

When this pin is pulled to ground via a 10 k Ω resistor, on the rising edge of reset, Auto-Negotiation is disabled. When this pin is left unconnected, on the rising edge of reset, Auto-Negotiation is enabled. Note that this pin acts in conjunction with Tech_Sel[2:0] on the rising edge of reset. Refer to Table 3 to determine the desired configuration for the device.

***Note:** By using resistors to hard wire the TECH_SEL[2:0] pins and the ANEGA pin, using the MDC/MDIO management interface pins becomes optional. The device's speed, duplex, and auto-negotiation capabilities are set via hardware. If the management interface is used, the registers cannot be set to a higher capability than the hard-wired setting. The highest capabilities are Full Duplex, 100 Mbps, and Auto-Negotiation enabled.*

RPTR**Repeater Mode** **Input**

This pin should be tied to ground via a 10 k Ω resistor if repeater mode is to be disabled. When this pin is pulled high via a 10 k Ω resistor, repeater mode will be enabled. Repeater mode can also be enabled via MII Register 16, bit 15.

LED Port Pins **$\overline{\text{LEDRX}}/\text{LED_SEL}$** **Receive LED/LED Configuration Select****Input/Output, Pull-Up**

When this pin is pulled low via a 5 k Ω resistor, on the rising edge of reset, the advanced LED configuration is enabled. If there is no pull-down resistor present, on the rising edge of reset, the standard LED configuration is enabled.

After the rising edge of reset this pin controls the Receive LED. This pin toggles between high and low when data is received. When the device is operating in the standard LED mode, refer to Table 4 and Figure 5 in the *LED Port Configuration* section. When the device is operating in the advanced LED mode, refer to Table 5 and Figure 6 in the *LED Port Configuration* section.

 $\overline{\text{LEDCOL}}/\text{SCRAM_EN}$ **Collision LED/Scrambler Enable****Input/Output, Pull-Up**

When this pin is pulled low via a 1-k Ω resistor, on the rising edge of reset, the scrambler/descrambler is disabled. If no pull-down resistor is present, on the rising edge of reset, the scrambler/descrambler is enabled.

After the rising edge of reset this pin controls the Collision LED. This pin toggles between high and low when there is a collision in half-duplex operation. In full-duplex operation this pin is inactive. When the device is operating in the standard LED mode (see $\overline{\text{LEDRX}}/\text{LED_SEL}$ pin description), refer to Table 4 and Figure 5 in the *LED Port Configuration* section. When the device is operating in the advanced LED mode (see $\overline{\text{LEDRX}}/\text{LED_SEL}$ pin description), see Table 5 and Figure 6.

 $\overline{\text{LEDLNK}}/\text{LED_10LNK}/\text{LED_PCSBP_SD}$ **Link LED/7-Wire Link LED/PCSBP Signal Detect****Output**

When a link is established in 100BASE-X or 10BASE-T mode, this pin will assume a logic low level.

When a link is established in 7-Wire mode, this pin will assume a logic high level.

When in PCS Bypass mode, this pin assumes a logic high level indicating Signal Detect.

Refer to Table 4 and Figure 4 in the *LED Port Configuration* section if the device is operating in the standard LED mode. See Table 5 and Figure 5 if the device is operating in the advanced LED mode.

Note: If 7-Wire mode is chosen the polarity of the LED should be reversed and the cathode of the LED should be tied to ground.

LEDSPD[0]/LEDBTA/FX_SEL

100 Mbps Speed LED/Advanced LED/Fiber Select Input/Output, Pull-Up

When this pin is pulled low via a 1 k Ω resistor, on the rising edge of reset, the device will be enabled for 100BASE-FX operation. When no pull-down resistor is present, on the rising edge of reset, the device will be enabled for 100BASE-TX or 10BASE-T operation.

When the standard LED configuration is enabled (see LEDRX/LEDSEL pin description), this pin serves as the 100 Mbps speed LED. A logic low level indicates 100 Mbps operation. A logic high level indicates 10 Mbps operation. Refer to Table 4 and Figure 5 in the *LED Port Configuration* section to determine the correct polarity of the LED.

When the advanced LED configuration is enabled, this pin works in conjunction with LEDTX/LEDBTB (pin 47). Refer to Table 5 and Figure 6 in the *LED Port Configuration* section to determine the correct polarity of the bi-directional LED.

LEDTX/LEDBTB

Transmit LED/Advanced LED Output

When the standard LED configuration is enabled (see LEDRX/LEDSEL pin description), this pin serves as the transmit LED. This pin toggles between high and low when data is transmitted. Refer to Table 4 and Figure 5 in the *LED Port Configuration* section to determine the correct polarity of the LED.

When the advanced LED configuration is enabled, this pin works in conjunction with LEDSPD[0]/LEDBTA/FX_SEL (pin 44). Refer to Table 5 and Figure 6 in the *LED Port Configuration* section to determine the correct polarity of the bi-directional LED.

LEDSPD[1]/LEDTXA/CLK25EN

10 Mbps Speed LED/Advanced LED/25 MHz Clock Enable Input/Output, Pull-Up

When this pin is pulled low via a 1 k Ω resistor, on the rising edge of reset, the device will output a 25 MHz clock on CLK25 (pin 6). When no pull-down resistor is present, on the rising edge of reset, CLK25 is inactive.

When the standard LED configuration is enabled (see LEDRX/LEDSEL pin description), this pin serves as the 10 Mbps speed LED. A logic low level indicates 10 Mbps operation. A logic high level indicates 100 Mbps operation. Refer to Table 4 and Figure 5 in the *LED Port Configuration* section to determine the correct polarity of the LED.

When the advanced LED configuration is enabled, this pin works in conjunction with LEDDPX/LEDTXB (pin 58). Refer to Table 5 and Figure 6 in the *LED Port Con-*

figuration section to determine the correct polarity of the bi-directional LED.

LEDDPX/LEDTXB

Duplex LED/Advanced LED Output

When the standard LED configuration is enabled (see LEDRX/LEDSEL description), this pin serves as the duplex LED. A logic low level indicates full duplex operation. A logic high level indicates half duplex operation. See Table 4 and Figure 5 in the *LED Port Configuration* section to determine the correct polarity of the LED.

When the advanced LED configuration is enabled, this pin works in conjunction with LEDSPD[1] LEDTXA/CLK25EN (pin 57). Refer to Table 5 and Figure 6 in the *LED Port Configuration* section to determine the correct polarity of the bi-directional LED.

Bias

IBREF

Reference Bias Resistor Analog

This pin must be tied to an external 10.0 k Ω (1%) resistor which should be connected to ground. The 1% resistor provides the bandgap reference voltage.

Power and Ground

PLLVCC, OVDD1, OVDD2, VDD1, VDD2, CRVVCC, ADPVCC, EQVCC, REFVCC, TVCC1, TVCC2 Power Pins Power

These pins are 3.3 V power for sections of the NetPHY-1LP device as follows:

PLLVCC is power for the PLL; OVDD1 and OVDD2 are power for the I/O; VDD1 and VDD2 are power for the digital logic; CRVVCC is power for clock recovery; ADPVCC and EQVCC are power for the equalizer; REFVCC is power for the bandgap reference; and TVCC1 and TVCC2 are power for the transmit driver.

PLLGND, OGN1, OGN2, DGN1, DGN2, CRVGND, EQGND, REFGND, TGN1, TGN2 Ground Pins Power

These pins are ground for the power pins as follows:

PLLGND is ground for PLLVCC; OGN1 is ground for OVDD; DGN1 is ground for VDD; CRVGND is ground for CRVVCC and ADPVCC; EQGND is ground for EQVCC; REFGND is ground for REFVCC; and TGN1 is ground for TVCC.

Note: Bypass capacitors of 0.1 μ F between the power and ground pins are recommended. The four areas where the capacitors must be very close to the pins (within 3 mm) are the PLL (pins 10 and 11), Clock Recovery (pins 51 and 52), Equalizer (pins 60 and 65), and Bandgap Reference (pins 71 and 73) areas. The other bypass capacitors should be placed as close to the pins as possible.

FUNCTIONAL DESCRIPTION

The NetPHY-1LP device integrates the 100BASE-X PCS, PMA, and PMD functions and the 10BASE-T Manchester ENDEC and transceiver functions in a single chip for Ethernet 10 Mbps and 100 Mbps operations. It performs 4B/5B, MLT3, NRZI, and Manchester encoding and decoding, clock and data recovery, stream cipher scrambling/descrambling, adaptive equalization, line transmission, carrier sense and link integrity monitor, Auto-Negotiation, and MII management functions. It provides an IEEE 802.3u compatible Media Independent Interface (MII) to communicate with an Ethernet Media Access Controller (MAC). Selection of 10 Mbps or 100 Mbps operation is based on settings of internal Serial Management Interface registers or determined by the on-chip Auto-Negotiation logic. The device can be set to operate either in full-duplex mode or half-duplex mode for either 10 Mbps or 100 Mbps.

The NetPHY-1LP device communicates with a repeater, switch, or MAC device through either the Media Independent Interface (MII) or the 10 Mbps 7-wire (GPSI) interface.

The NetPHY-1LP device consists of the following functional blocks:

- MII Mode
- 7-Wire (GPSI) Mode
- PCS Bypass (5B Symbol) Mode
- 100BASE-X Block including:
 - Transmit Process
 - Receive Process
 - 4B/5B Encoder and Decoder
 - Scrambler and Descrambler
 - Link Monitor
 - MLT-3
 - Adaptive Equalizer
 - Baseline Wander Compensation
 - Clock/Data Recovery
 - PLL Clock Synthesizer
- 10BASE-T Block including:
 - Transmit Process
 - Receive Process
 - Interface Status
 - Collision Detect
 - Jabber
 - Reverse Polarity Detection and Correction
- Auto-Negotiation and miscellaneous functions including:

- Auto-Negotiation
- Parallel Detection
- Far-End Fault
- SQE (Heartbeat)
- Loopback Operation
- Reset

- LED Port Configuration
- Power Savings Mechanisms including:
 - Selectable Transformer
 - Power Down
 - Unplugged
 - Idle Wire
- PHY Control and Management

Modes of Operation

The MII/GPSI/5B Symbol interface provides the data path connection between the NetPHY-1LP transceiver and the Media Access Controller (MAC), repeater, or switch. The MDC and MDIO pins are responsible for communication between the NetPHY-1LP transceiver and the station management entity (STA). The MDC and MDIO pins can be used in any mode of operation.

MII Mode

The purpose of the MII mode is to provide a simple, easy to implement connection between the MAC Reconciliation layer and the PHY. The MII is designed to make the differences between various media transparent to the MAC sublayer.

The MII consists of a nibble wide receive data bus, a nibble wide transmit data bus, and control signals to facilitate data transfers between the PHY and the Reconciliation layer.

- TXD (transmit data) is a nibble (4 bits) of data that are driven by the reconciliation sublayer synchronously with respect to TX_CLK. For each TX_CLK period which TX_EN is asserted, TXD[3:0] are accepted for transmission by the PHY.
- TX_CLK (transmit clock) output to the MAC reconciliation sublayer is a continuous clock that provides the timing reference for the transfer of the TX_EN, TXD, and TX_ER signals.
- TX_EN (transmit enable) input from the MAC reconciliation sublayer to indicate nibbles are being presented on the MII for transmission on the physical medium. TX_ER (transmit coding error) transitions synchronously with respect to TX_CLK. If TX_ER is asserted for one or more clock periods, and TX_EN is asserted, the PHY will emit one or more symbols that are not part of the valid data delimiter set somewhere in the frame being transmitted.

- RXD (receive data) is a nibble (4 bits) of data that is sampled by the reconciliation sublayer synchronously with respect to RX_CLK. For each RX_CLK period which RX_DV is asserted, RXD[3:0] are transferred from the PHY to the MAC reconciliation sublayer.
- RX_CLK (receive clock) output to the MAC reconciliation sublayer is a continuous clock (during LINK only) that provides the timing reference for the transfer of the RX_DV, RXD, and RX_ER signals.
- RX_DV (receive data valid) input from the PHY to indicate the PHY is presenting recovered and decoded nibbles to the MAC reconciliation sublayer. To interpret a receive frame correctly by the reconciliation sublayer, RX_DV must encompass the frame starting no later than the Start-of-Frame delimiter and excluding any End-Stream delimiter.
- RX_ER (receive error) transitions synchronously with respect to RX_CLK. RX_ER will be asserted for 1 or more clock periods to indicate to the reconciliation sublayer that an error was detected somewhere in the frame being received by the PHY.
- CRS (carrier sense) is asserted by the PHY when either the transmit or receive medium is non-idle and deasserted by the PHY when the transmit and receive medium are idle.

7-Wire (GPSI) Mode

7-Wire (GPSI) mode uses the existing MII pins, but data is transferred only on TXD[0] and RXD[0]. This mode is used in a General Purpose Serial Interface (GPSI) configuration for 10BASE-T. If the GPIO[0] pin is LOW at the rising edge of reset, then GPSI mode is selected. For this configuration, TX_CLK runs at 10 MHz. When the cable is unplugged, 10TXCLK ceases operation.

The MII pins that relate to 7-wire (GPSI) mode are shown in Table 1. The unused *input* pins in this mode should be tied to ground through a 1 kΩ resistor. The RPTR pin must be connected to GND.

Table 1. MII Pins That Relate to 10 Mbps 7-Wire (GPSI) Mode

MII Pin Name	7-Wire (GPSI)
TX_CLK/10TXCLK	Transmit Clock
TXD[0]/10TXD	Transmit Serial Data Stream
TXD[3:1]	Not used
TX_EN/10TXEN	Transmit Enable
TX_ER	Not used
RX_CLK/10RXCLK	Receive Clock
RXD[0]/10RXD	Receive Serial Data Stream
RXD[3:1]	Not used
COL/10COL	Collision Detect

MII Pin Name	7-Wire (GPSI)
RX_ER	Not used
CRS/10CRS	Carrier Sense Detect

Note: CRS ends one and one-half bit times after the last data bit. The effect is one or two dribbling bits on every packet. All MACs truncate packets to eliminate the dribbling bits. The only noticeable effect is that all CRC errors are recorded as framing errors.

Use the TECH_SEL[2:0] to select the desired 10BASE-T operation. For example, to auto-negotiate between Full Duplex and Half Duplex at 10 Mbps, set ANEG=1 and TECH[2:0]=101.

5B Symbol Mode

The purpose of the 5B Symbol mode is to provide a way for the MAC to do the 4B/5B encoding/decoding and scrambling/descrambling in 100 Mbps operation. This is useful in MAC similar to the Intel/DEC 21143 MAC.

In 10 Mbps operation, the MII signals are not used. Instead, the NetPHY-1LP device operates as a 10BASE-T transceiver, providing received data to the MAC over a serial differential pair (see Pin Descriptions, PCSBP pin). The MAC uses two serial differential pairs to provide transmit data to the NetPHY-1LP device, where the two differential pairs are combined in the NetPHY-1LP device to compensate for inter-symbol interference on the twisted pair medium.

100BASE-X Block

The functions performed by the device include encoding of MII 4-bit data (4B/5B), decoding of received code groups (5B/4B), generating carrier sense and collision detect indications, serialization of code groups for transmission, de-serialization of serial data upon reception, mapping of transmit, receive, carrier sense, and collision at the MII interface, and recovery of clock from the incoming data stream. It offers stream cipher scrambling and descrambling capability for 100BASE-TX applications.

In the transmit data path for 100 Mbps, the NetPHY-1LP transceiver receives 4-bit (nibble) wide data across the MII at 25 million nibbles per second. For 100BASE-TX applications, it encodes and scrambles the data, serializes it, and transmits an MLT-3 data stream to the media via an isolation transformer. For 100BASE-FX applications, it encodes and serializes the data and transmits a Pseudo-ECL (PECL) data stream to the fiber optic transmitter. See Figure 1.

In the receive data path for 100 Mbps, the NetPHY-1LP transceiver receives an MLT-3 data stream from the network. For 100BASE-TX, it then recovers the clock from the data stream, de-serializes the data stream, and descrambles/decodes the data stream (5B/4B) before presenting it at the MII interface.

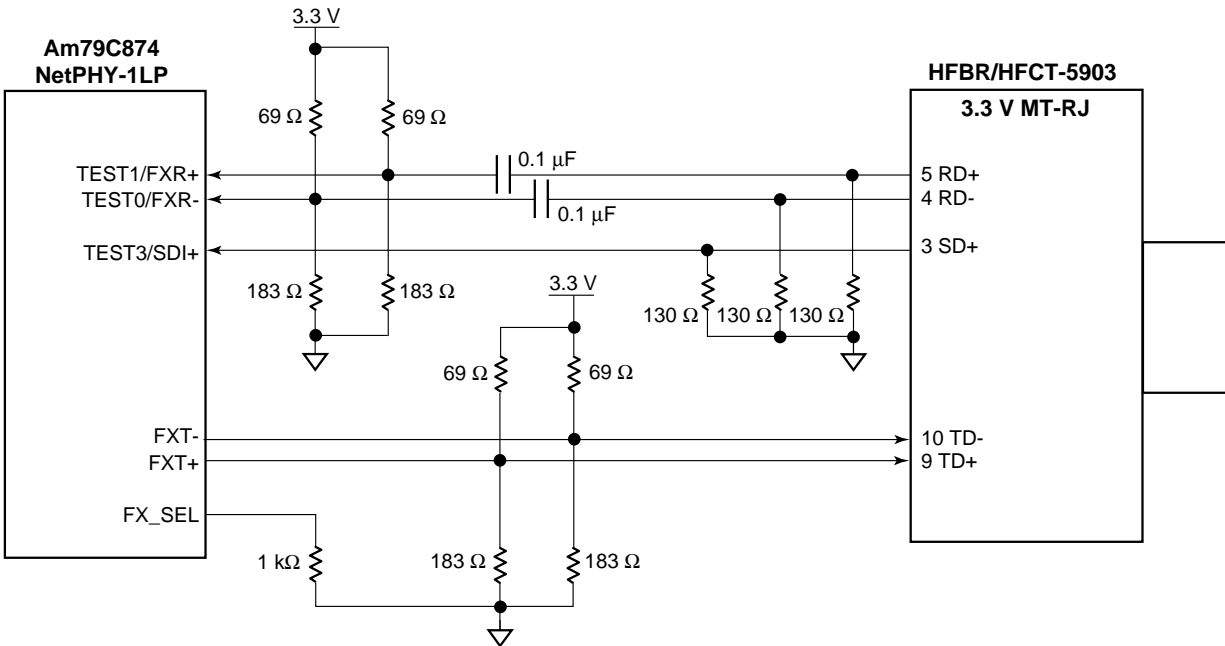

222351-3

Figure 1. FXT± and FXR± Termination for 100BASE-FX

For 100BASE-FX operation, the NetPHY-1LP device receives a PECL data stream from the fiber optic transceiver and decodes that data stream.

The 100BASE-X block consists of the following sub-blocks:

- Transmit Process
- Receive Process
- 4B/5B Encoder and Decoder
- Scrambler/Descrambler
- Link Monitor
- Far End Fault Generation and Detection & Code-Group Generator
- MLT-3 encoder/decoder with Adaptive Equalization
- Baseline Restoration
- Clock Recovery

Transmit Process

The transmit process generates code-groups based on the transmit control and data signals on the MII. This process is also responsible for frame encapsulation into a Physical Layer Stream, generating the collision signal based on whether a carrier is received simultaneously during transmission and generating the Carrier Sense CRS and Collision COL signals at the MII. The transmit process is implemented in compliance with the

transmit state diagram as defined in Clause 24 of the IEEE 802.3u specification.

The NetPHY-1LP device transmit function converts synchronous 4-bit data nibbles from the MII to a 125-Mbps differential serial data stream. The entire operation is synchronous to a 25-MHz clock and a 125-MHz clock. Both clocks are generated by an on-chip PLL clock synthesizer that is locked to an external 25-MHz clock source.

In 100BASE-FX mode, the NetPHY-1LP device will bypass the scrambler. The output data is an NRZI PECL signal. This PECL level signal will then drive the Fiber transmitter.

Receive Process

The receive path includes a receiver with adaptive equalization and DC restoration, MLT-3-to-NRZI conversion, data and clock recovery at 125-MHz, NRZI-to-NRZ conversion, Serial-to-Parallel conversion, descrambling, and 5B to 4B decoding. The receiver circuit starts with a DC bias for the differential RX± inputs, follows with a low-pass filter to filter out high-frequency noise from the transmission channel media. An energy detect circuit is also added to determine whether there is any signal energy on the media. This is useful in the power-saving mode. (See the description in *Power*

Savings Mechanisms section). All of the amplification ratio and slicer thresholds are set by the on-chip band-gap reference.

In 100BASE-FX mode, signal will be received through a PECL receiver, and directly passed to the clock recovery for data/clock extraction. In FX mode, the scrambler/descrambler cipher will be bypassed.

4B/5B Encoder/Decoder

The 100 Mbps process in the NetPHY-1LP device uses the 4B/5B encoding scheme as defined in IEEE 802.3, Section 24. This scheme converts between raw data on the MII and encoded data on the media pins. The encoder converts raw data to the 4B/5B code. It also inserts the stream boundary delimiters (/J/K/ and /T/R/) at the beginning and end of the data stream as appropriate. The decoder converts between encoded data on the media pins and raw data on the MII. It also detects the stream boundary delimiters to help determine the start and end of packets. The code-group mapping is defined in Table 2.

The 4B/5B encoding is bypassed when MII Register 21, bit 1 is set to “1”, or the PCSBP pin (pin 1) is strapped high.

Scrambler/Descrambler

The 4B/5B encoded data has repetitive patterns which result in peaks in the RF spectrum large enough to keep the system from meeting the standards set by regulatory agencies such as the FCC. The peaks in the radiated signal are reduced significantly by scrambling the transmitted signal. Scramblers add the output of a random generator to the data signal. The resulting signal has fewer repetitive data patterns.

After reset, the scrambler seed in each port will be set to the PHY address value to help improve the EMI performance of the device.

The scrambled data stream is descrambled at the receiver by adding it to the output of another random generator. The receiver’s random generator uses the same function as the transmitter’s random generator.

In 100BASE-TX mode, all 5-bit transmit data streams are scrambled as defined by the TP-PMD Stream

Cipher function in order to reduce radiated emissions on the twisted pair cable. The scrambler encodes a plain text NRZ bit stream using a key stream periodic sequence of 2047 bits generated by the recursive linear function:

$$X[n] = X[n-11] + X[n-9] \text{ (modulo 2)}$$

The scrambler reduces peak emissions by randomly spreading the signal energy over the transmit frequency range, thus eliminating peaks at a single frequency.

When MII Register 21, bit 2 is set to “1,” the data scrambling function is disabled and the 5-bit data stream is clocked directly to the device’s PMA sublayer.

Link Monitor

Signal levels are detected through a squelch detection circuit. A signal detect (SD) circuit following the equalizer is asserted high whenever the peak detector senses a post-equalized signal with a peak-to-ground voltage level larger than 400 mV. This is approximately 40 percent of the normal signal voltage level. In addition, the energy level must be sustained longer than 2 ms in order for the signal detect to be asserted. It gets de-asserted approximately 1 ms after the energy level is consistently less than 300 mV from peak-to-ground.

The link signal is forced to low during a local loopback operation (i.e., when MII Register 0, bit 14, Loopback is asserted) and forced to high when a remote loopback is taking place (i.e., when MII Register 21, bit 3, EN_RPBK, is set).

In 100BASE-TX mode, when no signal or an invalid signal is detected on the receive pair, the link monitor will enter in the “link fail” state where only the scrambled idle code will be transmitted. When a valid signal is detected for a minimum period of time, the link monitor will then enter the link pass state when transmit and receive functions are entered.

In 100BASE-FX mode, the external fiber-optic receiver performs the signal energy detection function and communicates this information directly to the NetPHY-1LP device through the SDI+ pin.

Table 2. Code-Group Mapping

MII (TXD[3:0])	Name	PCS Code-Group	Interpretation
0 0 0 0	0	1 1 1 1 0	Data 0
0 0 0 1	1	0 1 0 0 1	Data 1
0 0 1 0	2	1 0 1 0 0	Data 2
0 0 1 1	3	1 0 1 0 1	Data 3
0 1 0 0	4	0 1 0 1 0	Data 4
0 1 0 1	5	0 1 0 1 1	Data 5
0 1 1 0	6	0 1 1 1 0	Data 6
0 1 1 1	7	0 1 1 1 1	Data 7
1 0 0 0	8	1 0 0 1 0	Data 8
1 0 0 1	9	1 0 0 1 1	Data 9
1 0 1 0	A	1 0 1 1 0	Data A
1 0 1 1	B	1 0 1 1 1	Data B
1 1 0 0	C	1 1 0 1 0	Data C
1 1 0 1	D	1 1 0 1 1	Data D
1 1 1 0	E	1 1 1 0 0	Data E
1 1 1 1	F	1 1 1 0 1	Data F
Undefined	I	1 1 1 1 1	IDLE; used as inter-Stream fill code
0 1 0 1	J	1 1 0 0 0	Start-of-Stream Delimiter, Part 1 of 2; always used in pairs with K
0 1 0 1	K	1 0 0 0 1	Start-of-Stream Delimiter, Part 2 of 2; always used in pairs with J
Undefined	T	0 1 1 0 1	End-of-Stream Delimiter, Part 1 of 2; always used in pairs with R
Undefined	R	0 0 1 1 1	End-of-Stream Delimiter, Part 2 of 2; always used in pairs with T
Undefined	H	0 0 1 0 0	Transmit Error; used to force signaling errors
Undefined	V	0 0 0 0 0	Invalid Code
Undefined	V	0 0 0 0 1	Invalid Code
Undefined	V	0 0 0 1 0	Invalid Code
Undefined	V	0 0 0 1 1	Invalid Code
Undefined	V	0 0 1 0 1	Invalid Code
Undefined	V	0 0 1 1 0	Invalid Code
Undefined	V	0 1 0 0 0	Invalid Code
Undefined	V	0 1 1 0 0	Invalid Code
Undefined	V	1 0 0 0 0	Invalid Code
Undefined	V	1 1 0 0 1	Invalid Code

MLT-3

This block is responsible for converting the NRZI data stream from the PDX block to the MLT-3 encoded data stream. The effect of MLT-3 is the reduction of energy on the copper media (TX or FX cable) in the critical frequency range of 1 MHz to 100 MHz. The receive section of this block is responsible for equalizing and amplifying the received data stream and link detection. The adaptive equalizer compensates for the amplitude and phase distortion due to the cable.

MLT-3 is a tri-level signal. All transitions are between 0 V and +1 V or 0 V and -1 V. A transition has a logical value of 1 and a lack of a transition has a logical value of 0. The benefit of MLT-3 is that it reduces the maximum frequency over the data line. The bit rate of TX data is 125 Mbps. The maximum frequency (using NRZI) is half of 62.5 MHz. MLT-3 reduces the maximum frequency to 31.25 MHz.

A data signal stream following MLT-3 rules is illustrated in Figure 2. The data stream is 1010101.

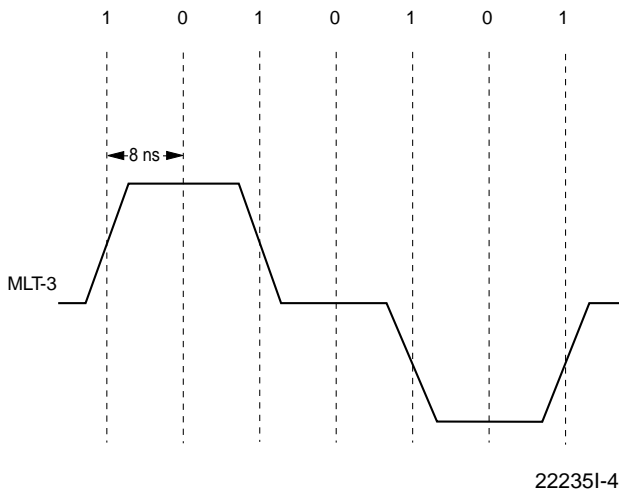

Figure 2. MLT-3 Waveform

The TX \pm drivers convert the NRZI serial output to MLT-3 format. The RX \pm receivers convert the received MLT-3 signals to NRZI. The transmit and receive signals will be compliant with IEEE 802.3u, Section 25. The required signals (MLT-3) are described in detail in ANSI X3.263:1995 TP-PMD Revision 2.2 (1995).

The NetPHY-1LP device provides on-chip filtering. External filters are not required for either the transmit or

receive signals. The traces from the transformer to the NetPHY-1LP device should have a controlled impedance as a differential pair of 100 ohms. The same is true between the transformer and the RJ-45 connector.

The TX \pm pins can be connected to the media via either a 1:1 transformer or a 1.25:1 transformer. The 1.25:1 ratio provides a 20% transmit power savings over the 1:1 ratio. Refer to Figure 3.

Adaptive Equalizer

The NetPHY-1LP device is designed to accommodate a maximum cable length of 140 meters UTP CAT-5 cable. 140 meters of UTP CAT-5 cable has an attenuation of 31 dB at 100 MHz. The typical attenuation of a 100 meter cable is 21 dB. The worst case attenuation is around 24-26 dB defined by TP-PMD.

The amplitude and phase distortion from the cable will cause intersymbol interference (ISI) which makes clock and data recovery impossible. The adaptive equalizer is made by closely matching the inverse transfer function of the twist-pair cable. This is a variable equalizer that changes its equalizer frequency response in accordance to cable length. The cable length is estimated based on comparisons of incoming signal strength against some of the known cable characteristics. The equalizer has a monotonical frequency response, and tunes itself automatically for any cable length to compensate for the amplitude and phase distortion incurred from the cable.

Baseline Wander Compensation

The 100BASE-TX data stream is not always DC balanced. The transformer blocks the DC component of the incoming signal, thus the DC offset of the differential receive inputs can wander. The shift in the signal levels, coupled with non-zero rise and fall times of the serial stream can cause pulse-width distortion. This creates jitter and a possible increase in error rates. Therefore, a DC restoration circuit is needed to compensate for the attenuation of the DC component.

The NetPHY-1LP device implements a patent-pending DC restoration circuit. Unlike the traditional implementation, it does not need the feedback information from the slicer and clock recovery circuit. This not only simplifies the system/circuit design, but also eliminates any random/systematic offset on the receive path. In 10BASE-T and 100Base-FX modes, the baseline wander correction circuit is not required and therefore will be bypassed.

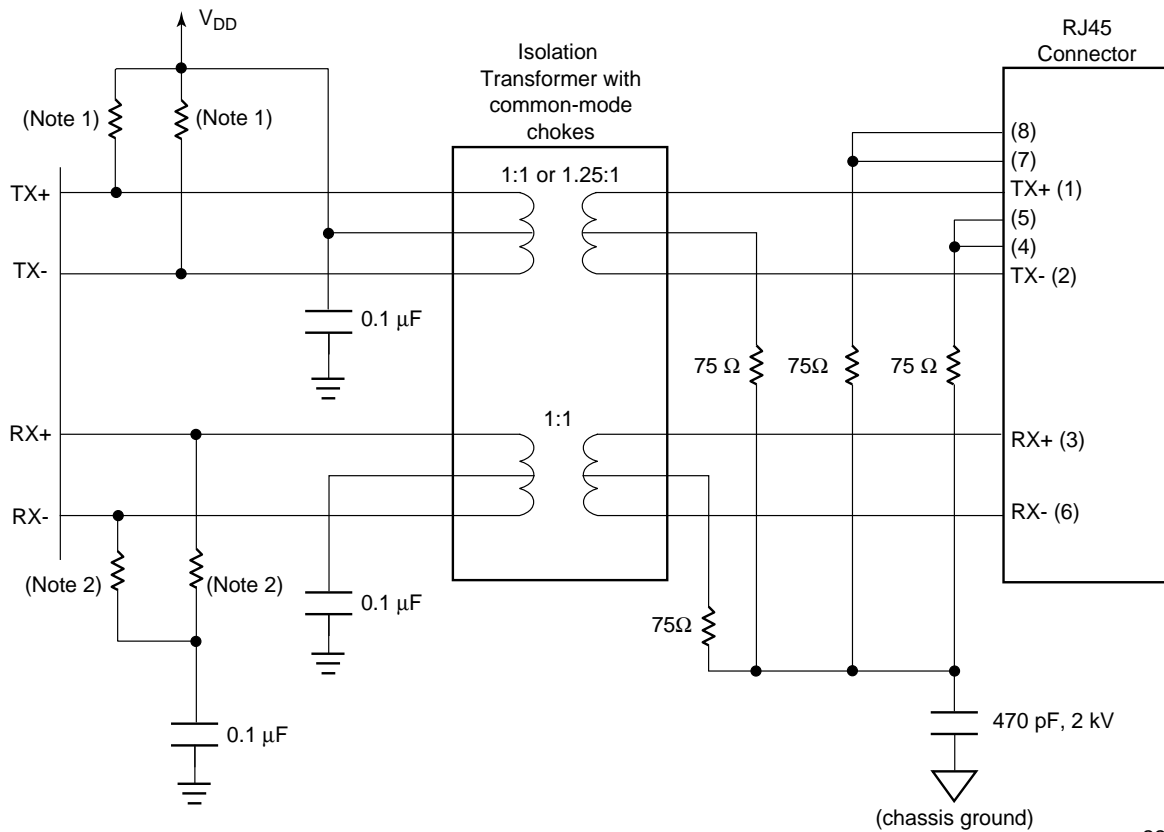
**Notes:**

1. 49.9 Ω if a 1:1 isolation transformer is used or 78.1 Ω if a 1.25:1 isolation transformer is used.
2. 49.9 Ω is normal, but 54.9 Ω can be used for extended cable length operation.

22235I-5

Figure 3. TX± and RX± Termination for 100BASE-TX and 10BASE-T**Clock/Data Recovery**

The equalized MLT-3 signal passes through a slicer circuit which then converts it to NRZI format. The NetPHY-1LP device uses an analog phase-locked loop (APLL) to extract clock information from the incoming NRZI data. The extracted clock is used to re-time the data stream and set the data boundaries. The transmit clock is locked to the 25-MHz clock input, while the receive clock is locked to the incoming data streams.

When initial lock is achieved, the APLL switches to lock to the data stream, extracts a 125 MHz clock from it and use that for bit framing to recover data. The recovered 125 MHz clock is also used to generate the 25 MHz RX_CLK. The APLL requires no external components for its operation and has high noise immunity and low jitter. It provides fast phase align (lock) to data in one transition and its data/clock acquisition time after power-on is less than 60 transitions.

The APLL can maintain lock on run-lengths of up to 60 data bits in the absence of signal transitions. When no valid data is present, i.e., when the SD is de-asserted,

the APLL switches back to lock with TX_CLK, thus providing a continuously running RX_CLK.

The recovered data is converted from NRZI-to-NRZ and then to a 5-bit parallel format. The 5-bit parallel data is not necessarily aligned to 4B/5B code-group's symbol boundary. The data is presented to PCS at receive data register output, gated by the 25-MHz RX_CLK.

PLL Clock Synthesizer

The NetPHY-1LP device includes an on-chip PLL clock synthesizer that generates a 125 MHz and a 25 MHz clock for the 100BASE-TX or a 100 MHz and 20 MHz clock for the 10BASE-T and Auto-Negotiation operations. Only one external 25 MHz crystal or a signal source is required as a reference clock.

After power-on or reset, the PLL clock synthesizer is defaulted to generating the 20 MHz clock output and will stay active until the 100BASE-X operation mode is selected.

10BASE-T Block

The NetPHY-1LP transceiver incorporates the 10BASE-T physical layer functions, including clock recovery (ENDEC), MAUs, and transceiver functions. The NetPHY-1LP transceiver receives 10-Mbps data from the MAC, switch, or repeater across the MII at 2.5 million nibbles per second (parallel), or 10 million bits per second (serial). It then Manchester encodes the data before transmission to the network.

Refer to Figure 4 for the 10BASE-T transmit and receive data paths.

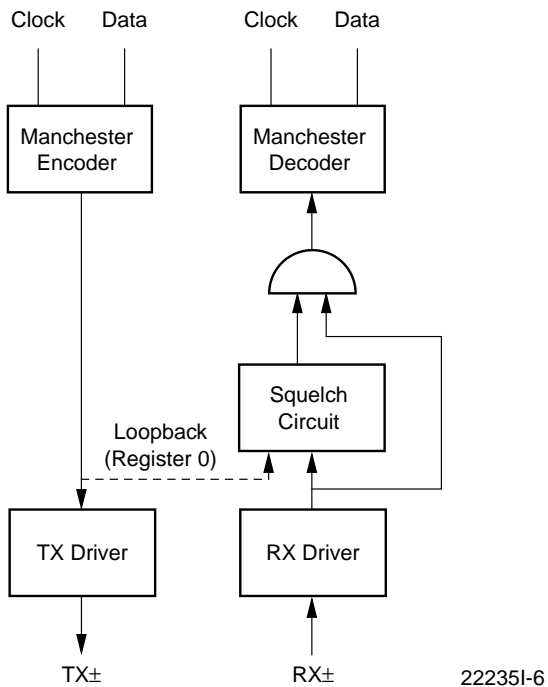

Figure 4. 10BASE-T Transmit /Receive Data Paths

Twisted Pair Transmit Process

In 10BASE-T mode, Manchester code will be generated by the 10BASE-T core logic, which will then be synthesized through the output waveshaping driver. This will help reduce any EMI emission, eliminating the need for an external filter. Data transmission over the 10BASE-T medium requires use of the integrated 10BASE-T MAU and uses the differential driver circuitry on the TX± pins.

TX± is a differential twisted-pair driver. When properly terminated, TX± meets the transmitter electrical requirements for 10BASE-T transmitters as specified in IEEE 802.3, Section 14.3.1.2. The load is a twisted pair cable that meets IEEE 802.3, Section 14.4.

The TX± signal is filtered on the chip to reduce harmonic content per Section 14.3.2.1 (10BASE-T). Since filtering is performed in silicon, TX± can be connected

directly to a standard transformer. External filtering modules are not needed

Twisted Pair Receive Process

In 10BASE-T mode, the signal first passes through a third order Elliptical filter, which filters all the noise from the cable, board, and transformer. This eliminates the need for a 10BASE-T external filter. A Manchester decoder and a Serial-to-Parallel converter then follow to generate the 4-bit nibble in MII mode.

RX± ports are differential twisted-pair receivers. When properly terminated, each RX± port meets the electrical requirements for 10BASE-T receivers as specified in IEEE 802.3, Section 14.3.1.3. Each receiver has internal filtering and does not require external filter modules or common mode chokes.

Signals appearing at the RX± differential input pair are routed to the internal decoder. The receiver function meets the propagation delays and jitter requirements specified by the 10BASE-T standard. The receiver squelch level drops to half its threshold value after un-squelch to allow reception of minimum amplitude signals and to mitigate carrier fade in the event of worst case signal attenuation and crosstalk noise conditions.

Twisted Pair Interface Status

The NetPHY-1LP transceiver will power up in the Link Fail state. The Auto-Negotiation algorithm will apply to allow it to enter the Link Pass state. A link-pulse detection circuit constantly monitors the RX± pins for the presence of valid link pulses. In the Link Pass state, receive activity which passes the pulse width/amplitude requirements of the RX± inputs cause the PCS Control block to assert Carrier Sense (CRS) signal at the MII interface.

Collision Detect Function

Simultaneous activity (presence of valid data signals) from both the internal encoder transmit function and the twisted pair RX± pins constitutes a collision, thereby causing the PCS Control block to assert the COL pin at the MII.

Collisions cause the PCS Control block to assert the Carrier Sense (CRS) and Collision (COL) signals at the MII. In the Link Fail state, this block would cause the PCS Control block to de-assert Carrier Sense (CRS) and Collision (COL).

Jabber Function

The Jabber function inhibits the 10BASE-T twisted pair transmit function of the NetPHY-1LP transceiver device if the TX± circuits are active for an excessive period (20-150 ms). This prevents one port from disrupting the network due to a *stuck-on* or faulty transmitter condition. If the maximum transmit time is exceeded, the data path through the 10BASE-T transmitter circuitry is disabled (although Link Test pulses will continue to be

sent). The PCS Control block also asserts the COL pin at the MII and sets the Jabber Detect bit in MII Register 1. Once the internal transmit data stream from the MENDEC stops, an *unjab* time of 250-750 ms will elapse before this block causes the PCS Control block to de-assert the COL indication and re-enable the transmit circuitry.

When jabber is detected, this block causes the PCS control block to assert the COL pin and allows the PCS Control block to assert or de-assert the CRS pin to indicate the current state of the RX± pair. If there is no receive activity on RX±, this block causes the PCS Control block to assert only the COL pin at the MII. If there is RX± activity, this block causes the PCS Control block to assert both COL and CRS at the MII. The Jabber function can be disabled by setting MII Register 21, bit 12.

Reverse Polarity Detection and Correction

Proper 10BASE-T receiver operation requires that the differential input signal be the correct polarity. That is, the RX+ line is connected to the RX+ input pin, and the RX- line is connected to the RX- input pin. Improper setup of the external wiring can cause the polarity to be reversed. The NetPHY-1LP receiver has the ability to detect the polarity of the incoming signal and compensate for it. Thus, the proper signal will appear on the MDI regardless of the polarity of the input signals.

The internal polarity detection and correction circuitry is set during the reception of the normal link pulses (NLP) or packets. The receiver detects the polarity of the input signal on the first NLP. It locks the polarity correction circuitry after the reception of two consecutive packets. The state of the polarity correction circuitry is locked as long as link is established.

Auto-Negotiation and Miscellaneous Functions

Auto-Negotiation

The NetPHY-1LP device has the ability to negotiate its mode of operation over the twisted pair using the Auto-Negotiation mechanism defined in Clause 28 of the IEEE 802.3u specification. Auto-Negotiation may be

enabled or disabled by hardware (ANEGA, pin 56) or software (MII Register 0, bit 12) control (see Table 3). The NetPHY-1LP device will automatically choose its mode of operation by advertising its abilities and comparing them with those received from its link partner whenever Auto-Negotiation is enabled.

The content of MII Register 4 is sent to the link partner during Auto-Negotiation, coded in Fast Link Pulses (FLPs). MII Register 4, bits 8:5 reflect the state of the TECH_SEL[2:0] pins after reset.

After reset, software can change any of these bits from 1 to 0 and back to 1, but not from 0 to 1 via the management interface. Therefore, hardware settings have priority over software. A write to Register 4 does not cause the device to restart Auto-Negotiation.

When Auto-Negotiation is enabled, the NetPHY-1LP device sends FLP during the one of the following conditions: (a) power on, (b) link loss, or (c) restart command. At the same time, the device monitors incoming data to determine its mode of operation. When the device receives a burst of FLPs from its link partner with three identical link code words (ignoring acknowledge bit), it stores these code words in MII Register 5 and waits for the next three identical code words. Once the device detects the second code word, it will configure itself to the highest technology that is common to both ends. The technology priorities are: (1) 100BASE-TX, full-duplex, (2) 100BASE-TX, half-duplex, (3) 10BASE-T, full-duplex, and (4) 10BASE-T half-duplex.

Parallel Detection

The parallel detection circuit is enabled as soon as either 10BASE-T idle or 100BASE-TX idle is detected. The mode of operation gets configured based on the technology of the incoming signal. The NetPHY-1LP device can also check for a 10BASE-T NLP or 100BASE-TX idle symbol. If either is detected, the device automatically configures to match the detected operating speed in half-duplex mode. This ability allows the device to communicate with legacy 10BASE-T and 100BASE-TX systems.

Table 3. Speed and Duplex Capabilities

ANEGA	Tech[2]	Tech[1]	Tech[0]	Speed	Duplex	ANEG-EN	Capabilities/ANEG
(Hardwired on Board)				(Changeable in MII Register 0)			
0	0	0	0	Yes (Note 1)	Yes (Note 1)	No	All Capabilities
0	0	0	1	No	No	No	10HD
0	0	1	0	No	No	No	100HD
0	0	1	1	No	No	No	100HD
0	1	0	0	Yes (Note 1)	Yes (Note 1)	No	All Capabilities
0	1	0	1	No	No	No	10FD
0	1	1	0	No	No	No	100FD
0	1	1	1	No	No	No	100FD
1	0	0	0	Yes (Note 3)	Yes (Note 3)	Yes (Note 2)	No Capabilities, ANEG
1	0	0	1	Yes (Note 3)	Yes (Note 3)	Yes (Note 2)	10HD, ANEG
1	0	1	0	Yes (Note 3)	Yes (Note 3)	Yes (Note 2)	100HD, ANEG
1	0	1	1	Yes (Note 3)	Yes (Note 3)	Yes (Note 2)	100HD, 10HD, ANEG
1	1	0	0	Yes (Note 3)	Yes (Note 3)	Yes (Note 2)	No Capabilities, ANEG
1	1	0	1	Yes (Note 3)	Yes (Note 3)	Yes (Note 2)	10FD/HD, ANEG
1	1	1	0	Yes (Note 3)	Yes (Note 3)	Yes (Note 2)	100FD/HD, ANEG
1	1	1	1	Yes (Note 2)	Yes (Note 3)	Yes (Note 2)	All Capabilities, ANEG

Notes:

1. MII Register 0 (speed and duplex bits) must be set by the MAC to achieve a link.
2. The advertised abilities in MII Register 4 cannot exceed the abilities of MII Register 1. Auto-Negotiation should always remain enabled.
3. When Auto-Negotiation is enabled, these bits can be written but will be ignored by the PHY.

Far-End Fault

Auto-Negotiation provides a remote fault capability for detecting asymmetric link failure. Since 100Base-FX systems do not use Auto-Negotiation, an alternative, in-band signaling scheme, Far-End Fault is used to signal remote fault conditions. Far-End Fault is a stream of 63 consecutive 1s followed by one logic 0. This pattern is repeated three times. A Far-End Fault will be signaled under three conditions: (1) when no activity is received from the link partner, (2) when the clock recovery circuit detects signal error or PLL lock error, and (3) when the management entity sets the transmit FEF bit (MII Register 21, bit 7).

The Far-End Fault mechanism defaults to enable 100BASE-FX mode and disable 100BASE-TX and 10BASE-T modes, and may be controlled by software after reset.

SQE (Heartbeat)

When the SQE test is enabled, a COL signal with a 5-15 bit time pulse will be issued after each transmitting packet. SQE is enabled and disabled via MII Register 16, bit 11.

Loopback Operation

A local loopback and remote loopback are provided for testing. They can be enabled by writing to either MII

Register 0, bit 14 (Loopback) or MII Register 21, bit 3 (EN_RPBK).

The local loopback routes transmitted data at the output of NRZ-to-NRZI conversion module back to the receiving path's clock and data recovery module for connection to PCS in 5 bits symbol format. This loopback is used to check all the connections at the 5-bit symbol bus side and the operation of analog phase locked loop. In local loopback, the SD output is forced to logic one and TX± outputs are tristated.

During local loopback, a 10-Mbps link is sent to the link partner. In either 100BASE-TX or 10BASE-T loopback mode, the link for 10 Mbps is forced (Register 21, bit 14) and is seen externally. If packets are transmitted from the Device Under Test (DUT), the link between the DUT and link partner is lost. Ceasing transmission causes the link to go back up.

In remote loopback, incoming data passes through the equalizer and clock recovery, then loop back to NRZI/MLT3 conversion module and out to the driver. This loopback is used to check the device's connection on the media side and the operation of its internal adaptive equalizer, phase-locked loop, and digital wave shape synthesizer. During remote loopback, signal detect (SD) output is forced to logic zero. Note that remote loopback operates only in 100BASE-TX mode.

External loopback can be accomplished using an external loopback cable with TX± connected to RX±. External loopback works for both 10 Mbps and 100 Mbps after setting Register 0, bit 8 to force full duplex and bit 13 to set the speed.

Reset

The NetPHY-1LP device can be reset in the three following ways:

1. During initial power on (with internal power on reset circuit).
2. At hardware reset. A logic low signal of 10 ms pulse width applied to the $\overline{\text{RST}}$ pin.
3. At software reset. Write a 1 to MII Register 0, bit 15.

LED Port Configuration

The NetPHY-1LP device has several pins that are used for both device configuration and LED drivers. These pins set the configuration of the device on the rising edge of $\overline{\text{RST}}$ and thereafter indicate the state of the respective port. See Table 4 for standard LED selections and Table 5 for advanced LED selections.

The polarity of the LED drivers (Active-LOW or Active-HIGH) is set at the rising edge of $\overline{\text{RST}}$. If the pin is LOW at the rising edge of $\overline{\text{RST}}$, it becomes an active-HIGH driver. If it is HIGH at the rising edge of $\overline{\text{RST}}$, it becomes an active-LOW driver.

Proper configuration requires pull-up or pull-down resistors. As shown in the Pin Description sections, each of the LED/Configuration pins has internal pull-up resistors. If the pin's LED functionality is not used, the pin may still need to be terminated via an external pull-down resistor according to the desired configuration. The resistor value is not critical and can be in the range of 1 k Ω to 10 k Ω . If the corresponding LED is used, the terminating resistor must be placed in parallel with the LED. Suggested LED connection diagrams simplifying the board design are shown in Figure 5 (standard) and Figure 6 (advanced).

The value of the series resistor (R_L) should be selected to ensure sufficient illumination of the LED. It is dependent on the rating of the LED.

Table 4. Standard LED Selections

MODE	$\overline{\text{LEDSDP}}[0]$	$\overline{\text{LEDSDP}}[1]$	$\overline{\text{LEDLNK}}$	$\overline{\text{LEDDPX}}$	$\overline{\text{LEDTX}}$	$\overline{\text{LEDRX}}$	$\overline{\text{LEDCOL}}$
No Link	0	0	0	0	0	0	0
10HD-RX	0	1	1	0	0	T	0
10HD-TX	0	1	1	0	T	0	0
10HD-COL	0	1	1	0	T	T	T
10FD-RX	0	1	1	1	0	T	0
10FD-TX	0	1	1	1	T	0	0
10FD-RX+TX	0	1	1	1	T	T	0
100HD-RX	1	0	1	0	0	T	0
100HD-TX	1	0	1	0	T	0	0
100HD-COL	1	0	1	0	T	T	T
100FD-RX	1	0	1	1	0	T	0
100FD-TX	1	0	1	1	T	0	0
100FD-RX+TX	1	0	1	1	T	T	0

Notes:

1. 1 means on (logic level low since active low).
2. 0 means off (logic level high since active low).
3. T means toggles (will end at logic level high).

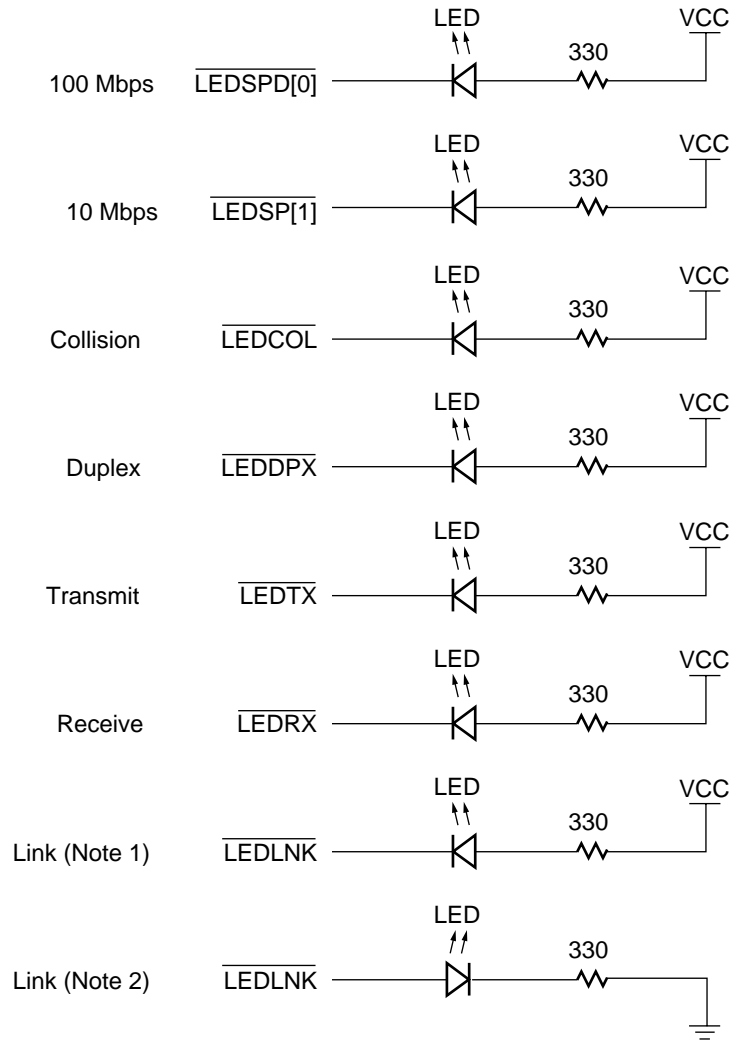

22235I-7

Notes:

- 1. Use for non 7-wire interface configurations.
- 2. Use for 7-wire interface configurations.

Figure 5. Standard LED Configuration

Table 5. Advanced LED Selections

MODE	LEDBTX/ LEDBTA (Pin 44)	LEDTX/ LEDBTB (Pin 47)	LEDBT/ LEDTXA (Pin 57)	LEDFOX/ LEDTXB (Pin 58)
No Link	0	0	0	0
10BT Half Duplex	1	0	0	0
10BT Half Activity	Flash (Note 1)	0	0	0
10BT Full Duplex	0	1	0	0
10BT Full Activity	0	Flash (Note 2)	0	0
100BT Half Duplex	0	0	1	0
100BT Half Activity	0	0	Flash (Note 1)	0
100BT Full Duplex	0	0	0	1
100BT Full Activity	0	0	0	Flash (Note 2)

Notes:

- 1. LED flashes for RX and TX activity.
- 2. LED flashes for RX activity.
- 3. 0 means logic level low at the pin.
- 4. 1 means logic level high at the pin.

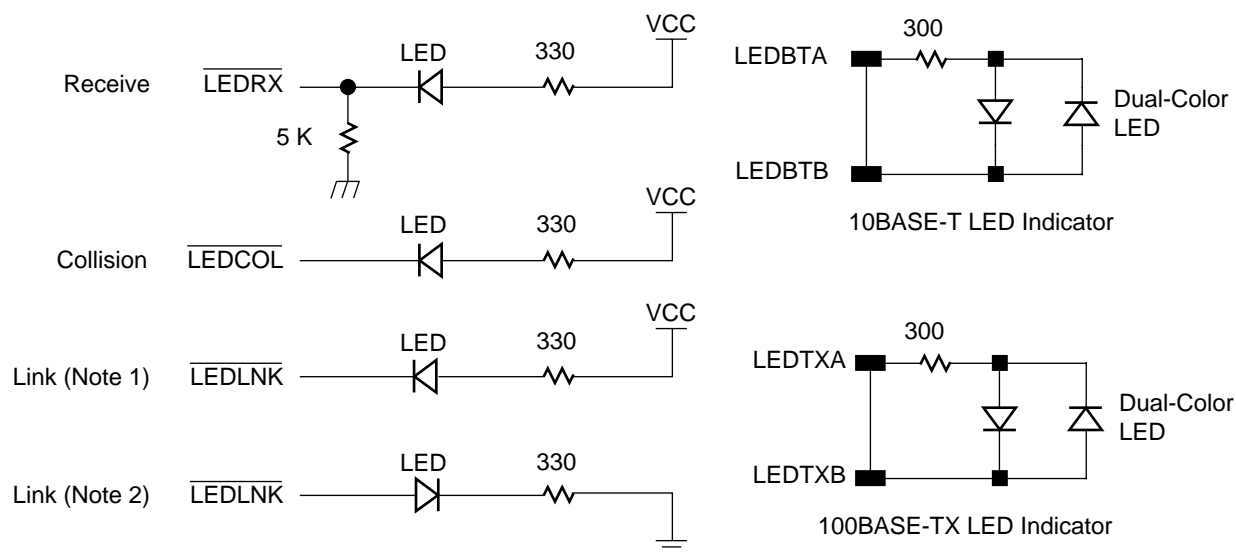
**Notes:**

1. Use for non 7-wire interface configurations.
2. Use for 7-wire interface configurations.

222351-8

Figure 6. Advanced LED Configuration**Power Savings Mechanisms**

The power consumption of the device is significantly reduced by its built-in power down features. Separate power supply lines are also used to power the 10BASE-T circuitry and the 100BASE-TX circuitry. Therefore, the two modes of operation can be turned-on and turned-off independently. Whenever the NetPHY-1LP device is set to operate in a 100BASE-TX mode, the 10BASE-T circuitry is powered down, and when in 10BASE-T mode, the 100BASE-TX circuitry is powered down.

The NetPHY-1LP device offers the following power management: Selectable Transformer, Power Down, Unplugged, and Idle.

Selectable Transformer

The TX outputs can drive either a 1:1 transformer or a 1.25:1 transformer. The latter can be used to reduce transmit power further. The current at the TX \pm pins for a 1:1 ratio transformer is 40 mA for MLT-3 and 100 mA for 10BASE-T. Using the 1.25:1 ratio reduces the current to 30 mA for MLT-3 and 67 mA for 10BASE-T.

The cost of using the 1.25:1 option is in impedance coupling. The reflected capacitance is increased by the square of the ratio ($1.25^2 = 1.56$). Thus, the reflected capacitance on the media side is roughly one and a half

times the capacitance on the board. Extra care in the layout to control capacitance on the board is required.

Power Down

Most of the NetPHY-1LP device can be disabled via the Power Down bit in MII Register 0, bit 11. Setting this bit will power down the entire device with the exception of the MDIO/MDC management circuitry.

Unplugged

The TX output driver limits the drive capability if the receiver does not detect a link partner within 4 seconds. This prevents “wasted” power. If the receiver detects the absence of a link partner, the transmitter is limited to transmitting normal link pulses. Any energy detected by the receiver enables full transmit and receive capabilities. The power savings is most notable when the port is unconnected. Typical power drops to one third of normal.

Idle Wire

This can be achieved by writing to MII Register 16, bit 0. During this mode, if there is no data other than idles coming in, the receive clock (RX_CLK) will turn off to save power for the attached controller. RX_CLK will resume operation one clock period prior to the assertion of RX_DV. The receive clock will again shut off 64 clock cycles after RX_DV gets deasserted. Typical power savings of 100 mW can be realized in some MACs.

PHY CONTROL AND MANAGEMENT BLOCK (PCM BLOCK)

Register Administration for 100BASE-X PHY Device

The management interface specified in Clause 22 of the IEEE 802.3u standard provides for a simple two wire, serial interface to connect a management entity and a managed PHY for the purpose of controlling the PHY and gathering status information. The two lines are Management Data Input/Output (MDIO), and Man-

agement Data Clock (MDC). A station management entity which is attached to multiple PHY entities must have prior knowledge of the appropriate PHY address for each PHY entity.

Description of the Methodology

The management interface physically transports management information across the MII. The information is encapsulated in a frame format as specified in Clause 22 of IEEE 802.3u draft standard and is shown in Table 6.

Table 6. Clause 22 Management Frame Format

	PRE	ST	OP	PHYAD	REGADD	TA	DATA	IDLE
READ	1.1	01	10	AAAAA	RRRRR	Z0	D.....D	Z
WRITE	1.1	01	01	AAAAA	RRRRR	10	D.....D	Z

The PHYAD field, which is five bits wide, allows 32 unique PHY addresses. The managed PHY layer device that is connected to a station management entity via the MII interface has to respond to transactions addressed to the PHY address. A station management

entity attached to multiple PHYs, such as in a managed 802.3 Repeater or Ethernet switch, is required to have prior knowledge of the appropriate PHY address. See Table 7 and Figure 7.

Table 7. PHY Address Setting Frame Structure

	PRE	ST	OP	PHYAD	REGADD	TA	DATA	IDLE
READ	1.1	01	10	00000	RRRRR	Z0	XXXXXXXXPPAAAAA	Z
WRITE	1.1	01	01	00000	RRRRR	10	XXXXXXXXPPAAAAA	Z

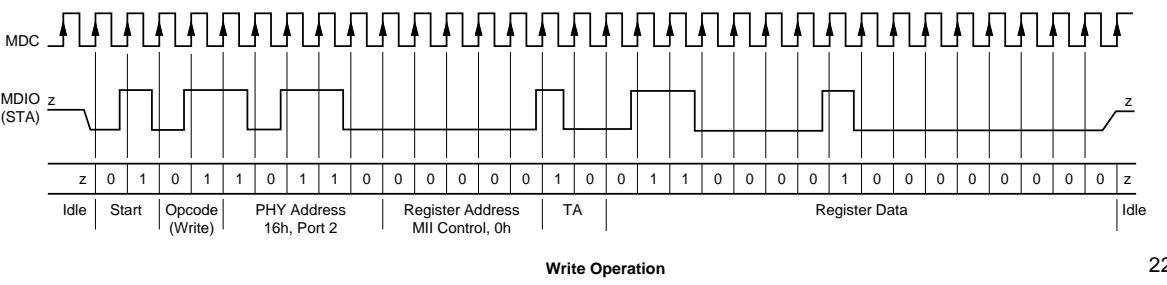
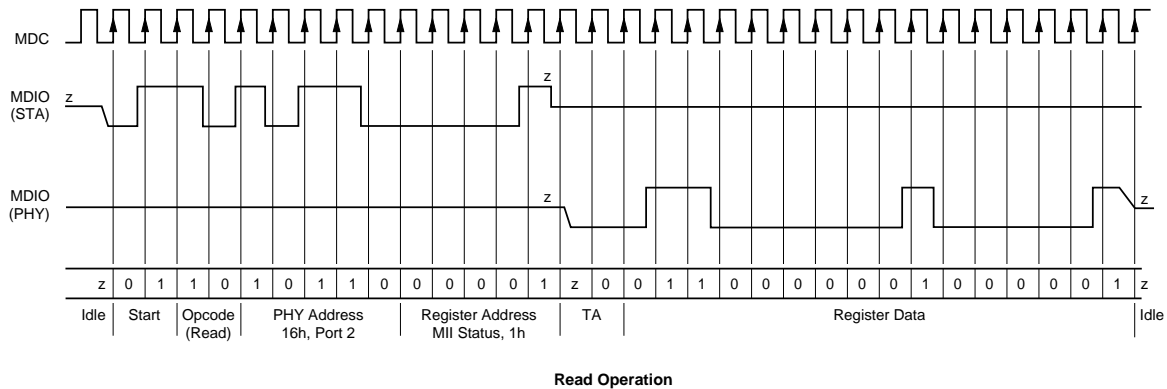

Figure 7. PHY Management Read and Write Operations

22235I-9

Bad Management Frame Handling

The management block of the device can recognize management frames without preambles (preamble suppression). However, if it receives a bad management frame, it will go into a Bad Management Frame state. It will stay in this state and will not respond to any management frame without preambles until a frame with a full 32-bit preamble is received, then it will return to normal operation.

A bad management frame is a frame that does not comply with the IEEE standard specification. It can be one with less than 32-bit preamble, with illegal OP field, etc. However, a frame with more than 32 preamble bits is considered to be a good frame.

After a reset, the NetPHY-1LP device requires a minimum preamble of 32 bits before management data (MDIO) can be received. After that, the management data being received by the NetPHY-1LP device does not require a preamble.

REGISTER DESCRIPTIONS

The following registers given in Table 8 are supported (register addresses are in decimal).

Table 8. Register Summary

Register Address (in Decimal)	Description
0	MII Management Control Register
1	MII Management Status Register
2	PHY Identifier 1 Register
3	PHY Identifier 2 Register
4	Auto-Negotiation Advertisement Register
5	Auto-Negotiation Link Partner Ability Register
6	Auto-Negotiation Expansion Register
7	Next Page Advertisement Register
8-15	Reserved
16	Miscellaneous Features Register
17	Interrupt Control/Status Register
18	Diagnostic Register
19	Power Management & Loopback Register
20	Reserved
21	Mode Control Register
22	Reserved
23	Disconnect Counter
24	Receive Error Counter
25-31	Reserved

The Physical Address of the PHY is set using the pins defined as PHYAD[4:0]. These input signals are strapped externally and sampled as when reset goes high. The PHYAD pins can be reprogrammed via software.

Serial Management Registers

A detailed definition of each Serial Management register follows. The mode legend is shown in Table 9.

Table 9. Legend for Register Table

Type	Description
RW	Readable and writable
SC	Self Clearing
LL	Latch Low until clear
RO	Read Only
RC	Cleared on the read operation
LH	Latch high until clear

MII Management Control Register (Register 0)

Table 10. MII Management Control Register (Register 0)

Reg	Bit	Name	Description	Read/Write	Default
0	15	Reset	1 = PHY reset. 0 = Normal operation. This bit is self-clearing.	RW/SC	0
0	14	Loopback	1 = Enable loopback mode. This will loopback TXD to RXD, thus it will ignore all the activity on the cable media. During loopback, a 10-Mbps link is sent to the link partner (Register 21, bit 14 is forced.) 0 = Disable Loopback mode. Normal operation.	RW	0
0	13	Speed Select	1 = 100 Mbps, 0 = 10 Mbps. This bit will be ignored if Auto Negotiation is enabled (0.12 = 1). Refer to Table 3 to determine when this bit can be changed.	RW	Set by TECH[2:0] pins
0	12	Auto-Neg Enable	1 = Enable auto-negotiate process (overrides 0.13 and 0.8). 0 = Disable auto-negotiate process. Mode selection is controlled via bit 0.8, 0.13 or through TECH[2:0] pins. Refer to Table 3 to determine when this bit can be changed.	RW	Set by ANEGA pin
0	11	Power Down	1 = Power down. The NetPHY-1LP device will shut off all blocks except for MDIO/MDC interface. Setting PWRDN pin to high will achieve the same result. 0 = Normal operation.	RW	0
0	10	Isolate	1 = Electrically isolate the PHY from MII. However, PHY is still able to respond to MDC/MDIO. The default value of this bit depends on ISODEF pin, i.e., ISODEF=1, ISO bit will set to 1, & ISODEF=0, ISO bit will set to 0. 0 = Normal operation.	RW	Set by ISODEF pin
0	9	Restart Auto-Negotiation	1 = Restart Auto-Negotiation process. 0 = Normal operation.	RW/SC	0
0	8	Duplex Mode	1 = Full duplex, 0 = Half duplex. Refer to Table 3 to determine when this bit can be changed.	RW	Set by TECH[2:0] pins
0	7	Collision Test	1 = Enable collision test, which issues the COL signal in response to the assertion of TX_EN signal. Collision test is disabled if PCSBP pin is high. Collision test is enabled regardless of the duplex mode. 0 = disable COL test.	RW	0
0	6:0	Reserved	Write as 0, ignore when read.	RW	0

MII Management Status Register (Register 1)

Table 11. MII Management Status Register (Register 1)

Reg	Bit	Name	Description	Read/Write	Default
1	15	100BASE-T4	1 = 100BASE-T4 able. 0 = Not 100BASE-T4 able.	RO	0
1	14	100BASE-TX Full Duplex	1 = 100BASE-TX Full Duplex. 0 = No 100BASE-TX Full Duplex ability.	RO	set by TECH[2:0] pins
1	13	100BASE-TX Half Duplex	1 = 100BASE-TX Half Duplex. 0 = No TX half-duplex ability.	RO	set by TECH[2:0] pins
1	12	10BASE-T Full Duplex	1 = 10BASE-T Full Duplex. 0 = No 10BASE-T Full Duplex ability.	RO	set by TECH[2:0] pins
1	11	10BASE-T Half Duplex	1 = 10BASE-T Half Duplex. 0 = No 10BASE-T ability.	RO	set by TECH[2:0] pins
1	10:7	Reserved	Ignore when read.	RO	0
1	6	Management Frame Preamble Suppression	The device accepts management frames that do not have a preamble after receiving a management frame with a 32-bit or longer preamble.	RO	1
1	5	Auto-Negotiation Complete	1 = Auto-Negotiation process completed. Registers 4, 5, and 6 are valid after this bit is set. 0 = Auto-Negotiation process not completed.	RO	0
1	4	Remote Fault	1 = Remote fault condition detected. 0 = No remote fault. This bit will remain set until it is read via the management interface.	RO/LH	0
1	3	Auto-Negotiation Ability	1 = Able to perform Auto-Negotiation function; value is determined by ANEGA pin. 0 = Unable to perform Auto-Negotiation function.	RO	set by ANEGA pin
1	2	Link Status	1 = Link is established; however, if the NetPHY-1LP device link fails, this bit will be cleared and remain cleared until Register 1 is read via management interface. 0 = link is down.	RO/LL	0
1	1	Jabber Detect	1 = Jabber condition detected. 0 = No Jabber condition detected.	RO/LH	0
1	0	Extended Capability	1 = Extended register capable. This bit is tied permanently to one.	RO	1

PHY Identifier 1 Register (Register 2)

Table 12. PHY Identifier 1 Register (Register 2)

Reg	Bit	Name	Description	Read/Write	Default
2	15	OUI	Composed of the 3rd through 18th bits of the Organizationally Unique Identifier (OUI), respectively.	RO	0022(H)

PHY Identifier 2 Register (Register 3)

Table 13. PHY Identifier 2 Register (Register 3)

Reg	Bit	Name	Description	Read/Write	Default
3	15:10	OUI	Assigned to the 19th through 24th bits of the OUI.	RO	010101
3	9:4	Model Number	Six-bit manufacturer's model number.	RO	100001
3	3:0	Revision Number	Four-bit manufacturer's revision number.	RO	1011

Auto-Negotiation Advertisement Register (Register 4)

Table 14. Auto-Negotiation Advertisement Register (Register 4)

Reg	Bit	Name	Description	Read/Write	Default
4	15	Next Page	1 = Next Page enabled. 0 = Next Page disabled.	RW	0
4	14	Acknowledge	This bit will be set internally after receiving three consecutive and consistent FLP bursts.	RO	0
4	13	Remote Fault	1 = Remote fault supported. 0 = No remote fault.	RW	0
4	12:11	Reserved	For future technology.	RW	0
4	10	FDFC	Full Duplex Flow Control: 1 = Advertise that the DTE(MAC) has implemented both the optional MAC control sublayer and the pause function as specified in clause 31 and annex 31 B of 802.3u. 0 = No MAC-based full duplex flow control.	RW	0
4	9	100BASE-T4	NetPHY-1LP device does not support 100BASE-T4 function, i.e., this bit ties to zero.	RO	0
4	8	100BASE-TX Full Duplex	1 = 100BASE-TX Full Duplex. 0 = No 100BASE-TX Full Duplex ability. Default is set by Register 1.14.	RW	set by TECH [2:0] pins
4	7	100BASE-TX Half Duplex	1 = 100BASE-TX Half Duplex. 0 = No 100BASE-TX Half Duplex capability. Default is set by Register 1.13	RW	set by TECH[2:0] pins
4	6	10BASE-T Full Duplex	1 = 10 Mbps Full Duplex. 0 = No 10 Mbps Full Duplex capability. Default is set by Register 1.12.	RW	set by TECH[2:0] pins
4	5	10BASE-T Half Duplex	1 = 10 Mbps Half Duplex. 0 = No 10 Mbps Half Duplex capability Default is set by Register 1.11.	RW	set by TECH[2:0] pins
4	4:0	Selector Field	[00001] = IEEE 802.3.	RO	00001

Auto-Negotiation Link Partner Ability Register in Base Page Format (Register 5)

Table 15. Auto-Negotiation Link Partner Ability Register in Base Page Format (Register 5)

Reg	Bit	Name	Description	Read/Write	Default
5	15	Next Page	1 = Next Page Requested by Link Partner 0 = Next Page Not Requested	RO	0
5	14	Acknowledge	1 = Link Partner Acknowledgement 0 = No Link Partner Acknowledgement	RO	0
5	13	Remote Fault	1 = Link Partner Remote Fault Request 0 = No Link Partner Remote Fault Request	RO	0
5	12:11	Reserved	Reserved for Future Technology	RO	
5	10	Flow Control	1 = Link Partner supports Flow Control. 0 = Link Partner does not support Flow Control.	RO	0
5	9	100BASE-T4	1 = Remote Partner is 100BASE-T4 Capable 0 = Remote Partner is not 100BASE-T4 Capable	RO	0
5	8	100BASE-TX Full Duplex	1 = Link Partner is capable of 100BASE-TX Full Duplex 0 = Link Partner is Not Capable of 100BASE-TX Full Duplex	RO	0
5	7	100BASE-TX Half Duplex	1 = Link Partner is Capable of 100BASE-TX Half Duplex 0 = Link Partner is Not Capable of 100BASE-TX Half Duplex	RO	0
5	6	10BASE-T Full Duplex	1 = Link Partner is capable of 10BASE-T Full Duplex 0 = Link Partner is Not Capable of 10BASE-T Full Duplex	RO	0
5	5	10BASE-T Half Duplex	1 = Link Partner is capable of 10BASE-T Half Duplex 0 = Link Partner is Not Capable of 10BASE-T Half Duplex	RO	0
5	4:0	Selector Field	Link Partner Selector Field	RO	00001

Auto-Negotiation Link Partner Ability Register in Next Page Format (Register 5)

Table 16. Auto-Negotiation Link Partner Ability Register in Next Page Format (Register 5)

Reg	Bit	Name	Description	Read/Write	Default
5	15	Next Page	1 = Next Page Requested by Link Partner 0 = Next Page Not Requested	RO	0
5	14	Acknowledge	1 = Link Partner Acknowledgement 0 = No Link Partner Acknowledgement	RO	0
5	13	Message Page	1 = Link Partner message Page Request 0 = No Link partner Message Page Request	RO	0
5	12	Acknowledge 2	1 = Link Partner can Comply Next Page Request 0 = Link Partner cannot Comply Next Page Request	RO	0
5	11	Toggle	Link Partner Toggle	RO	0
5	10:0	Message Field	Link Partner's Message Code	RO	0

Auto-Negotiation Expansion Register (Register 6)

Table 17. Auto-Negotiation Expansion Register (Register 6)

Reg	Bit	Name	Description	Read/ Write	Default
6	15:5	Reserved	Ignore when read.	RO	0
6	4	Parallel Detection Fault	1 = Fault detected by parallel detection logic. This fault is due to more than one technology detecting concurrent link up conditions. This bit is cleared upon reading this register. 0 = No fault detected by parallel detection logic.	RO/LH	0
6	3	Link Partner Next Page Able	1 = Link partner supports next page function. 0 = Link partner does not support next page function.	RO	0
6	2	Next Page Able	Next page is supported. This bit is permanently tied to 1.	RO	1
6	1	Page Received	This bit is set when a new link code word has been received into the Auto-Negotiation Link Partner Ability Register. This bit is cleared upon reading this register.	RO/LH	0
6	0	Link Partner Auto-Negotiation Able	1 = Link partner is auto-negotiation able. 0 = Link partner is not auto-negotiation able.	RO	0

Auto-Negotiation Next Page Advertisement Register (Register 7)

Table 18. Auto-Negotiation Next Page Advertisement Register (Register 7)

Reg	Bit	Name	Description	Read/ Write	Default
7	15	NP	Next page indication: 1 = Another Next Page desired. 0 = No other Next Page Transfer desired.	RW	0
7	14	Reserved	Ignore when read.	RO	0
7	13	MP	Message page: 1 = Message page. 0 = Un-formatted page.	RW	1
7	12	ACK2	Acknowledge 2: 1 = Will comply with message. 0 = Cannot comply with message.	RW	0
7	11	TOG_TX	Toggle: 1 = Previous value of transmitted link code word equals to 0. 0 = Previous value of transmitted link code word equals to 1.	RW	0
17	10:0	CODE	Message/Un-formatted Code Field.	RW	001

Reserved Registers (Registers 8-15, 20, 22, 25-31)

The NetPHY-1LP device contains reserved registers at addresses 8-15, 20, 22, 25-31. These registers should be ignored when read and should not be written at any time.

Miscellaneous Features Register (Register 16)

Table 19. Miscellaneous Features Register (Register 16)

Reg	Bit	Name	Description	Read/Write	Default
16	15	Repeater	1 = Repeater mode, full-duplex is inactive, and CRS only responds to receive activity. SQE test function is also disabled.	RW	Set by RPTR
16	14	INTR_LEVL	INTR will be active high if this register bit is set to 1. Pin requires an external pull-down resistor. INTR will be active low if this register bit is set to 0. Pin requires an external pull-up resistor.	RW	0
16	13:12	Reserved	Write as 0, ignore when read.	RW	0
16	11	SQE Test Inhibit	1 = Disable 10BASE-T SQE testing. 0 = Enable 10BASE-T SQE testing. A COL pulse is generated following the completion of a packet transmission.	RW	0
16	10	10BASE-T Loopback	1 = Enable normal loopback in 10BASE-T mode. 0 = Disable normal loopback in 10BASE-T mode.	RW	1
16	9	GPIO_1 Data	When GPIO_1 DIR bit is set to 1, this bit reflects the value of the GPIO[1] pin. When GPIO_1 DIR bit is set to 0, the value of this bit will be presented on the GPIO[1] pin.	RW	0
16	8	GPIO_1 DIR	1 = GPIO[1] pin is an input. 0 = GPIO[1] pin is an output.	RW	1
16	7	GPIO_0 Data	When GPIO_0 DIR bit is set to 1, this bit reflects the value of the GPIO[0] pin. When GPIO[0] DIR bit is set to 0, the value of this bit will be presented on the GPIO[0] pin.	RW	0
16	6	GPIO_0 DIR	1 = GPIO[0] pin is an input. 0 = GPIO[0] pin is an output.	RW	1
16	5	Auto polarity Disable	1 = Disable auto polarity detection/correction. 0 = Enable auto polarity detection/correction.	RW	0
16	4	Reverse Polarity	When Register 16.5 is set to 0, this bit will be set to 1 if reverse polarity is detected on the media. Otherwise, it will be 0. When Register 16.5 is set to 1, writing a 1 to this bit will reverse the polarity of the transmitter. Note: Reverse polarity is detected either through eight inverted NLPs or through a burst of an inverted FLP.	RW	0
16	3:1	Reserved	Write as 0, ignore when read.	RO	0
16	0	Receive Clock Control	Writing a 1 to this bit will shut off RX_CLK when incoming data is not present and only if there is LINK present. RX_CLK will resume activity one clock cycle prior to RX_DV going high, and shut off 64 clock cycles after RX_DV goes low. A 0 indicates that RX_CLK runs continuously during LINK whether data is received or not In loopback and PCS bypass modes, writing to this bit does not affect RX_CLK. Receive clock will be constantly active.	RW	0

Interrupt Control/Status Register (Register 17)

Table 20. Interrupt Control/Status Register (Register 17)

Reg	Bit	Name	Description	Read/Write	Default
17	15	Jabber_IE	Jabber Interrupt Enable	RW	0
17	14	Rx_Er_IE	Receive Error Interrupt Enable	RW	0
17	13	Page_Rx_IE	Page Received Interrupt Enable	RW	0
17	12	PD_Fault_IE	Parallel Detection Fault Interrupt Enable	RW	0
17	11	LP_Ack_IE	Link Partner Acknowledge Interrupt Enable	RW	0
17	10	Link_Not_OK_IE	Link Status Not OK Interrupt Enable	RW	0
17	9	R_Fault_IE	Remote Fault Interrupt Enable	RW	0
17	8	ANeg_Comp_IE	Auto-Negotiation Complete Interrupt Enable	RW	0
17	7	Jabber_Int	This bit is set when a jabber event is detected.	RC	0
17	6	Rx_Er_Int	This bit is set when RX_ER transitions high.	RC	0
17	5	Page_Rx_Int	This bit is set when a new page is received from link partner during Auto-Negotiation.	RC	0
17	4	PD_Fault_Int	This bit is set for a parallel detection fault.	RC	0
17	3	LP_Ack_Int	This bit is set when an FLP with the acknowledge bit set is received.	RC	0
17	2	Link_Not_OK Int	This bit is set when link status switches from OK status to Not-OK (Fail or Ready).	RC	0
17	1	R_Fault_Int	This bit is set when a remote fault is detected.	RC	0
17	0	A_Neg_Comp Int	This bit is set when Auto-Negotiation is complete.	RC	0

Note: * See Interrupt Source Table for bit assignments.

Diagnostic Register (Register 18)

Table 21. Diagnostic Register (Register 18)

Reg	Bit	Name	Description	Read/Write	Default
18	15:12	Reserved	Ignore when read.	RO	0
18	11	DPLX	1 = The result of Auto-Negotiation for Duplex is Full-duplex. 0 = The result of Auto-Negotiation for Duplex is Half-duplex.	RO	0
18	10	Data Rate	1 = The result of Auto-Negotiation for data-rate arbitration is 100 Mbps. 0 = The result of Auto-Negotiation for data-rate arbitration is 10 Mbps.	RO	0
18	9	RX_PASS	Operating in 100BASE-X mode: 1 = A valid signal has been received but the PLL has not necessarily locked. 0 = A valid signal has not been received. Operating in 10BASE-T mode: 1 = Manchester data has been detected. 0 = Manchester data has not been detected.	RO	0
18	8	RX_LOCK	1 = Receive PLL has locked onto received signal for selected data-rate (10BASE-T or 100BASE-X). 0 = Receive PLL has not locked onto received signal. This bit remains set until it is read.	RO/RC	0
18	7:0	Reserved	Ignore when read.	RO	0

Power/Loopback Register (Register 19)

Table 22. Power/Loopback Register (Register 19)

Reg	Bit	Name	Description	Read/ Write	Default
19	14:7	Reserved		RW	00
19	6	TP125	Transmit transformer ratio selection: 1 = 1.25:1 0 = 1:1 The default value of this bit is controlled by reset-read value of pin 20.	RW	0
19	5	Low Power Mode	1 = Enable advanced power saving mode. 0 = Disable advanced power saving mode <i>Note: Under normal operating conditions, this mode should never be disabled. Power dissipation will exceed data sheet values, as circuitry for both 10 Mbps and 100 Mbps will be turned on.</i>	RW	1
19	4	Test Loopback	1 = Enable test loopback. Data will be transmitted from MII interface to clock recovery and loopback to MII received data.	RW	0
19	3	Digital loopback	1 = Enable loopback. 0 = Normal operation.	RW	0
19	2	LP_LPBK	1 = Enable link pulse loopback. 0 = Normal operation.	RW	0
19	1	NLP Link Integrity Test	1 = In Auto-Negotiation test mode, send NLP instead of FLP in order to test NLP receive integrity. 0 = Sending FLP in Auto-Negotiation test mode.	RW	0
19	0	Reduce Timer	1 = Reduce time constant for Auto-Negotiation timer. 0 = Normal operation.	RW	0

Mode Control Register (Register 21)

Table 23. Mode Control Register (Register 21)

Reg	Bit	Name	Description	Read/Write	Default
21	15	Reserved		RO	0
21	14	Force_Link_10	1 = Force link up without checking NLP. Forced during local loopback. 0 = Normal Operation.	RW	0
21	13	Force_Link_100	1 = Ignore link in 100BASE-TX and transmit data. Auto-Negotiation must be disabled at this time (pin 56 tied low). 0 = Normal Operation.	RW	0
21	12	Jabber Disable	1 = Disable Jabber function in PHY. 0 = Enable Jabber function in PHY.	RW	0
21	11	7_Wire_Enable	1 = Enable 7-wire interface for 10BASE-T operation. This bit is useful only when the chip is not in PCS bypass mode. 0 = Normal operation.	RW	0
21	10	CONF_ALED	1 = Activity LED only responds to receive operation. 0 = Activity LED responds to receive and transmit operations for Half Duplex. LED responds to receive activity in Full Duplex operation. This bit should be ignored when Register 0.8 is set to 1 or during repeater mode operation.	RW	0
21	9	LED_SEL	1 = Select NetPHY-1LP device 's Standard LED configuration. 0 = Use the Advanced LED configuration.	RW	Set by LEDRX/ LED_SEL
21	8	FEF_DISABLE	0 = Enable far-end-fault generation and detection function. 1 = Disable far-end-fault. This bit should be ignored when FX mode is disabled.	RW	Set by TECH[2:0], FX_SEL, ANEGA pins
21	7	Force FEF Transmit	This bit is set to force to transmit Far End Fault (FEF) pattern.	RW	0
21	6	RX_ER_CNT Full	When Receive Error Counter is full, this bit will be set to 1.	RO/ RC	0
21	5	Disable RX_ER_CNT	1 = Disable Receive Error Counter. 0 = Enable Receive Error Counter.	RW	0
21	4	DIS_WDT	1 = Disable the watchdog timer in the decipher. 0 = Enable watchdog timer.	RW	0
21	3	EN_RPBK	1 = Enable remote loopback (MDI loopback for 100BASE-TX). 0 = Disable remote loopback.	RW	0
21	2	EN_SCRM	1 = Enable data scrambling. 0 = Disable data scrambling. When FX mode is selected, this bit will be forced to 0.	RW	Set by SCRAM_EN pin
21	1	PCSBP	1 = Bypass PCS. 0 = Enable PC.	RW	Set by PCSBP pin
21	0	FX_SEL	1 = FX mode selected. 0 = Disable FX mode.	RW	Set by FX_SEL pin

Disconnect Counter Register (Register 23)

Table 24. Disconnect Counter (Register 23)

Reg	Bit	Name	Description	Read/ Write	Default
23	15:0	DLOCK drop counter	Count of PLL lock drop events	RW	0000

Receive Error Counter Register (Register 24)

Table 25. Receive Error Counter Register (Register 24)

Reg	Bit	Name	Description	Read/ Write	Default
24	15:0	RX_ER counter	Count of receive error events	RW	0000

ABSOLUTE MAXIMUM RATINGS

Storage Temperature -55°C to +150°C
 Ambient Temperature Under Bias . . . -55°C to +150°C
 Supply Voltage -0.5 V to +5.5 V
 Voltage Applied to any input pin. -0.5 V to V_{DD}

Stresses above those listed under Absolute Maximum Ratings may cause permanent device failure. Functionality at or above these limits is not implied. Exposure to absolute maximum ratings for extended periods may affect device reliability.

OPERATING RANGES**Commercial (C):**

Operating Temperature (TA) 0°C to +70°C
 Supply Voltage (All V_{DD}) +3.3 V \pm 5%
 Supply Voltage (5-V tolerant pins). +5.0 V \pm 5%

Industrial (I):

Operating Temperature (TA) -40°C to +85°C
 Supply Voltage (All V_{DD}) +3.3 V \pm 5%
 Supply Voltage (5-V tolerant pins). +5.0 V \pm 5%

Operating ranges define those limits between which functionality of the device is guaranteed.

DC CHARACTERISTICS

Note: Parametric values are the same for Commercial and Industrial devices.

Symbol	Parameter Description	Test Conditions	Minimum	Maximum	Units
V_{IL}	Input LOW Voltage			0.8	V
V_{IH}	Input HIGH Voltage		2.0		V
V_{OL}	Output LOW Voltage	$I_{OL} = 8$ mA		0.4	V
V_{OH}	Output HIGH Voltage	$I_{OH} = -4$ mA	2.4		V
V_{OLL}	Output LOW Voltage (LED)	$I_{OL} (LED) = 10$ mA		0.4	V
V_{OHL}	Output HIGH Voltage (LED)	$I_{OL} (LED) = -10$ mA	$V_{DD} - 0.4$		V
V_{CMP}	Input Common-Mode Voltage PECL (Note 1)		$V_{DD} - 1.5$	$V_{DD} - 0.7$	V
V_{IDIFFP}	Differential Input Voltage PECL (Note 1)	$V_{DD} =$ Maximum	400	1,100	mV
V_{OHP}	Output HIGH Voltage PECL (Note 4)	PECL Load	$V_{DD} - 1.025$	$V_{DD} - 0.60$	V
V_{OLP}	Output LOW Voltage PECL (Note 4)	PECL Load	$V_{DD} - 1.81$	$V_{DD} - 1.62$	V
V_{SDA}	Signal Detect Assertion Threshold P/P (Note 2)	MLT-3/10BASE-T Test Load	-	1000	mV
V_{SDD}	Signal Detect Deassertion Threshold P/P (Note 3)	MLT-3/10BASE-T Test Load	200	-	mV
I_{IL}	Input LOW Current (Note 12)	$V_{DD} =$ Maximum $V_{IN} = 0.0$ V		-40	μ A
I_{IH}	Input HIGH Current (Note 12)	$V_{DD} =$ Maximum $V_{IN} = 2.7$ V		40	μ A
V_{TXOUT}	Differential Output Voltage (Note 5)	MLT-3/10BASE-T Test Load	950	1050	mV
V_{TXOS}	Differential Output Overshoot (Note 5)	MLT-3/10BASE-T Test Load	-	$0.05 * V_{TXOUT}$	V
V_{TXR}	Differential Output Voltage Ratio (Note 5 & Note 6)	MLT-3/10BASE-T Test Load	0.98	1.02	-

DC CHARACTERISTICS (CONTINUED)

Symbol	Parameter Description	Test Conditions	Minimum	Maximum	Units
V_{TSQ}	RX± 10BASE-T Squelch Threshold	Sinusoid 5 MHz<f<10 MHz	300	585	mV
V_{THS}	RX± Post-Squelch Differential Threshold 10BASE-T	Sinusoid 5 MHz<f<10 MHz	150	293	mV
V_{RXDTH}	10BASE-T RX± Differential Switching Threshold	Sinusoid 5 MHz<f<10 MHz	-60	60	mV
V_{TX10NE}	10BASE-T Near-End Peak Differential Voltage (Note 7)	MLT-3/10BASE-T Test Load	2.2	2.8	V
I_{OZ}	Output Leakage Current (Note 10)	$0.4\text{ V} < V_{OUT} < V_{DD}$	-30	30	μA
C_{IN}	Input Capacitance XTL± (Note 13)			3	pF
I_{CC}	Power Supply Current	10BASE-T, idle 10BASE-T, normal activity 10BASE-T, peak 100BASE-TX 100BASE-TX, no cable Power down	-	30 105 130 100 20 1	mA

Notes:

1. Applies to TEST1/ FXR+, TEST0/FXR-, and SDI+ inputs only. Valid only when in PECL mode.
2. Applies to RX± inputs when in MLT-3 mode only. The RX± input is guaranteed to assert internal signal detect for any valid peak-to-peak input signal greater than $V_{SDA\ MIN}$.
3. Applies to RX± inputs when in MLT-3 mode only. The RX± input is guaranteed to de-assert internal signal for any peak to peak signal less than $V_{SDD\ MAX}$.
4. Applies to FXT+ and FXT- outputs only. Valid only when in PECL mode.
5. Applies to TX± differential outputs only. Valid only when in the MLT-3 mode.
6. V_{TXR} is the ratio of the magnitude of TX± in the positive direction to the magnitude of TX± in the negative direction.
7. Only valid for TX output when in the 10BASE-T mode.
8. An I_{OLL} value applies to LED pins.
9. Applies to all output pins on the MII port.
10. I_{OZ} applies to all high-impedance output pins and all bi-directional pins. For COL and CRS parameters, I_{OZH} limits are up to 40 μA , and $IOZL$ up to -500 μA .
11. 75% activity means 25% IPG and 75% data. 100% activity means minimum IPG.
12. Applies to digital inputs and all bidirectional pins. These pins may have internal pull-up or pull-down resistors. RX± limits up to 1.0 mA max for I_{IL} and -1.0 mA for I_{IH} . XTL± limits up to 6.0 mA for I_{IL} and -6.0 mA for I_{IH} . External pull-up/pull-down resistors affect this value.
13. Parameter not measured.

SWITCHING WAVEFORMS

Key to Switching Waveforms

WAVEFORM	INPUTS	OUTPUTS
	Must be Steady	Will be Steady
	May Change from H to L	Will be Changing from H to L
	May Change from L to H	Will be Changing from L to H
	Don't Care, Any Change Permitted	Changing, State Unknown
	Does Not Apply	Center Line is High-Impedance "Off" State

KS000010-PAL

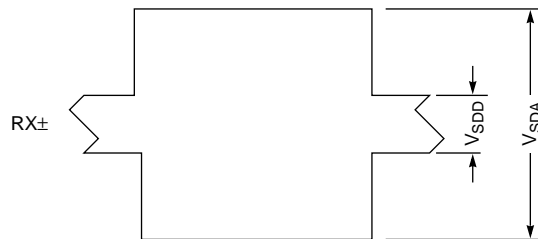

222351-10

Figure 8. MLT-3 Receive Input

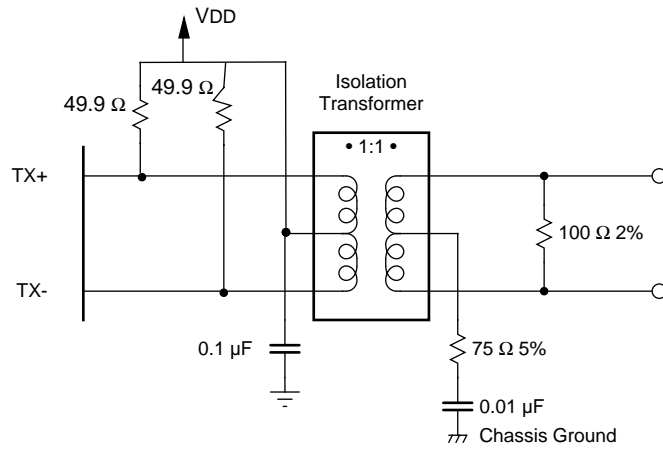

222351-11

Figure 9. MLT-3 and 10BASE-T Test Load with 1:1 Transformer Ratio

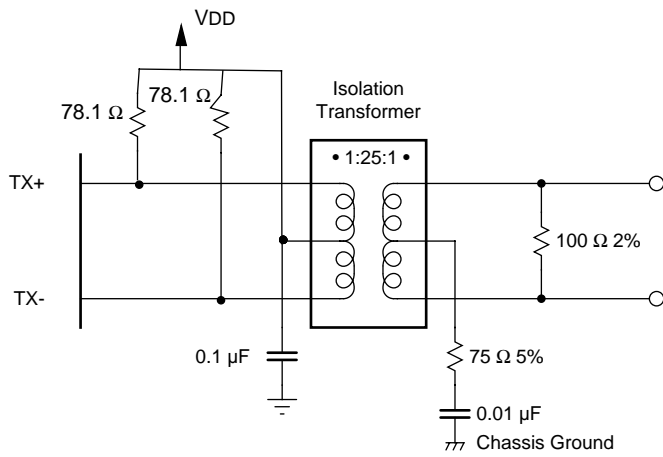

222351-12

Figure 10. MLT-3 and 10BASE-T Test Load with 1.25:1 Transformer Ratio

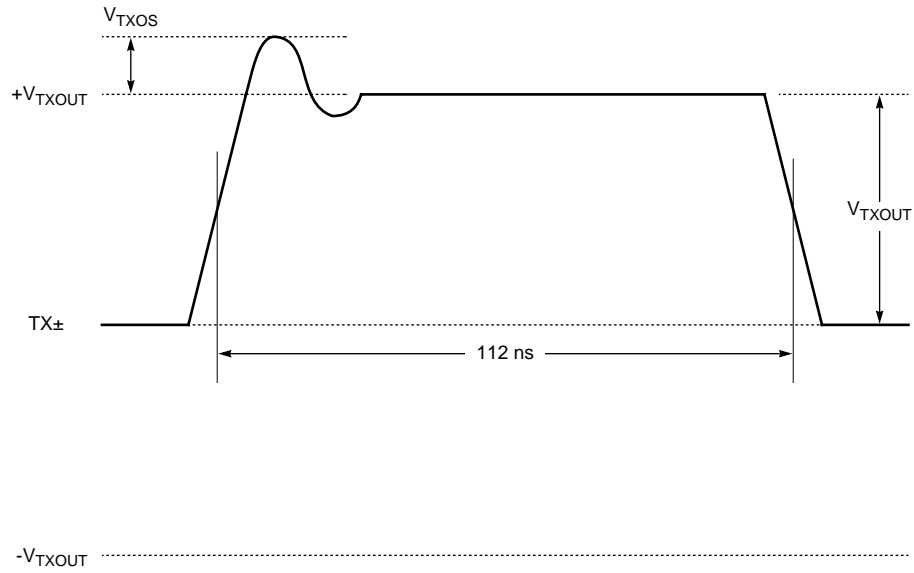

222351-13

Figure 11. Near-End 100BASE-TX Waveform

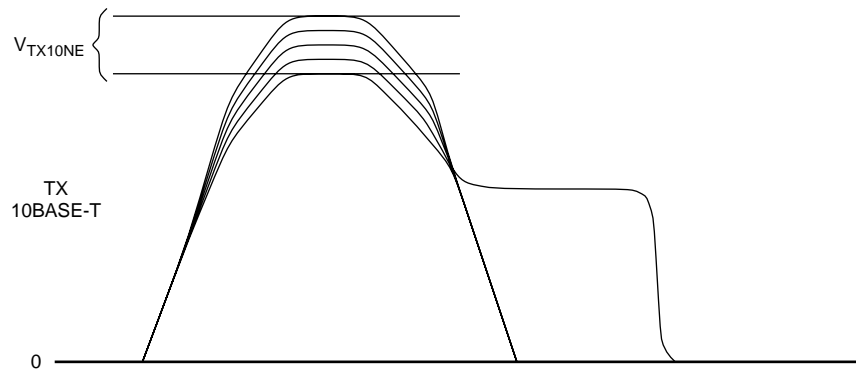

222351-14

Figure 12. 10BASE-T Waveform With 1:1 Transformer Ratio

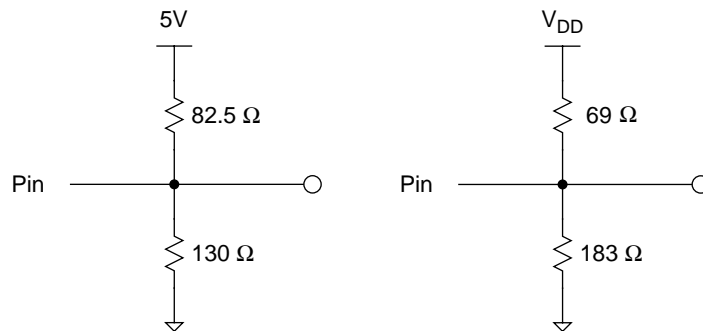

222351-15

Figure 13. PECL Test Loads

SWITCHING CHARACTERISTICS

Note: Parametric values are the same for commercial devices and industrial devices.

System Clock Signal

Symbol	Parameter Description	Min.	Max.	Unit
t_{CLK}	REFCLK Period	39.998	40.002	ns
t_{CLKH}	REFCLK Width HIGH	18	22	ns
t_{CLKL}	REFCLK Width LOW	18	22	ns
t_{CLR}	REFCLK Rise Time	-	5	ns
t_{CLF}	REFCLK Fall Time	-	5	ns

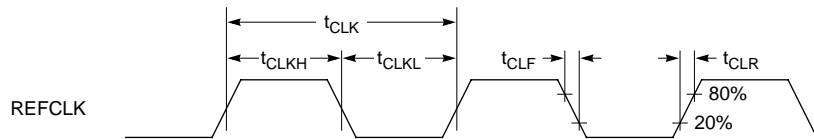

22235I-16

Figure 14. Clock Signal

MLT-3 Signals

Symbol	Parameter Description	Min.	Max.	Unit
t_{TXR}	Rise Time of MLT-3 Signal	3.0	5.0	ns
t_{TXF}	Fall Time of MLT-3 Signal	3.0	5.0	ns
t_{TXRFS}	Rise Time and Fall Time Symmetry of MLT-3 Signal	-	5	%
t_{TXDCD}	Duty Cycle Distortion Peak to Peak	-	0.5	ns
t_{TXJ}	Transmit Jitter Using Scrambled Idle Signals	-	1.4	ns

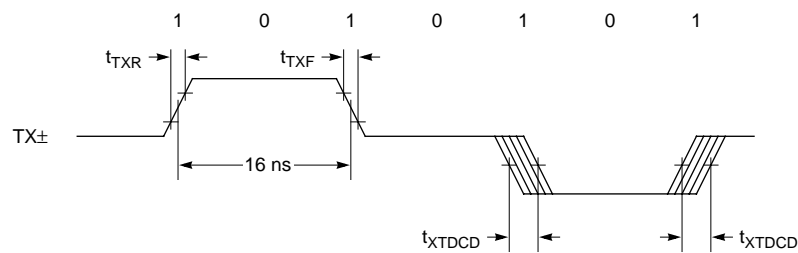

22235I-17

Figure 15. MLT-3 Test Waveform

MII Management Signals

Symbol	Parameter Description	Min.	Max.	Unit
t_{MDPER}	MDC Period	40		ns
t_{MDWH}	MDC Pulse Width HIGH	16		ns
t_{MDWL}	MDC Pulse Width LOW	16		ns
t_{MDPD}	MDIO Delay From Rising Edge of MDC		20	ns
t_{MDS}	MDIO Setup Time to Rising Edge of MDC	4		ns
t_{MDH}	MDIO Hold Time From Rising Edge of MDC	3		ns

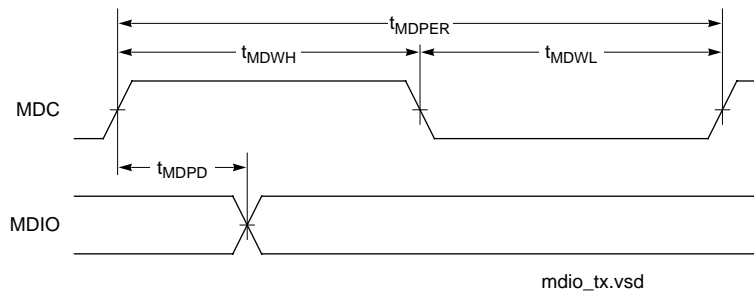

222351-18

Figure 16. Management Bus Transmit Timing

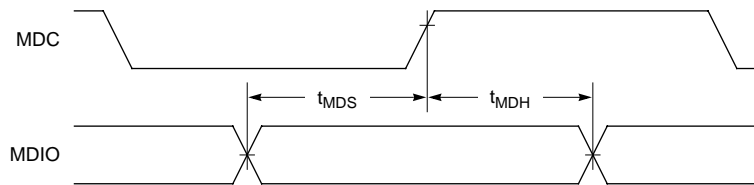

222351-19

Figure 17. Management Bus Receive Timing

MII Signals

100 Mbps MII Transmit Timing

Symbol	Parameter Description	Min.	Max.	Unit
$t_{M\text{TS}100}$	TX_ER, TX_EN, TXD[3:0] Setup Time to TX_CLK Rising Edge	12	-	ns
$t_{M\text{TH}100}$	TX_ER, TX_EN, TXD[3:0] Hold time From TX_CLK Rising Edge	0	-	ns
$t_{M\text{TEJ}100}$	Transmit Latency TX_EN Sampled by TX_CLK to First Bit of /J/	60	140	ns
$t_{M\text{TECRH}100}$	CRS Assert From TX_EN Sampled HIGH	-	40	ns
$t_{M\text{TECOH}100}$	COL Assert From TX_EN Sampled HIGH	-	200	ns
$t_{M\text{TDCRL}100}$	CRS De-assert From TX_EN Sampled LOW	-	160	ns
$t_{M\text{TDCOL}100}$	COL De-assert From TX_EN Sampled LOW	13	240	ns
$t_{M\text{TIDLE}100}$	Required De-assertion Time Between Packets	120	-	ns
$t_{M\text{TP}100}$	TX_CLK Period	39.998	40.002	ns
$t_{M\text{TWH}100}$	TX_CLK HIGH	18	22	ns
$t_{M\text{TWL}100}$	TX_CLK LOW	18	22	ns

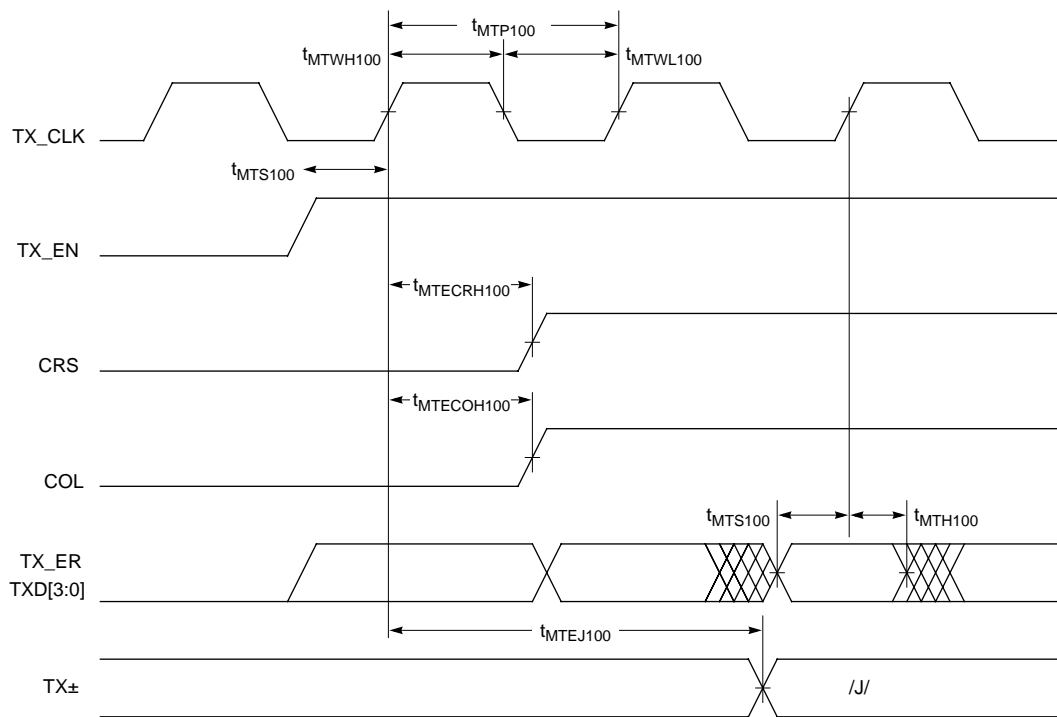

222351-20

Figure 18. 100 Mbps MII Transmit Start of Packet Timing

100 Mbps MII Transmit Timing (Continued)

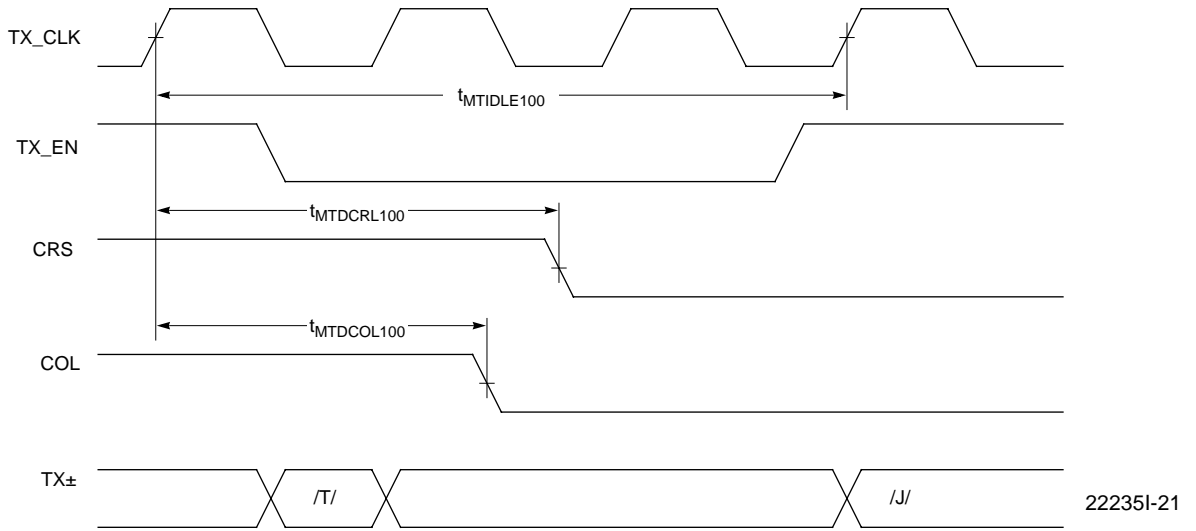
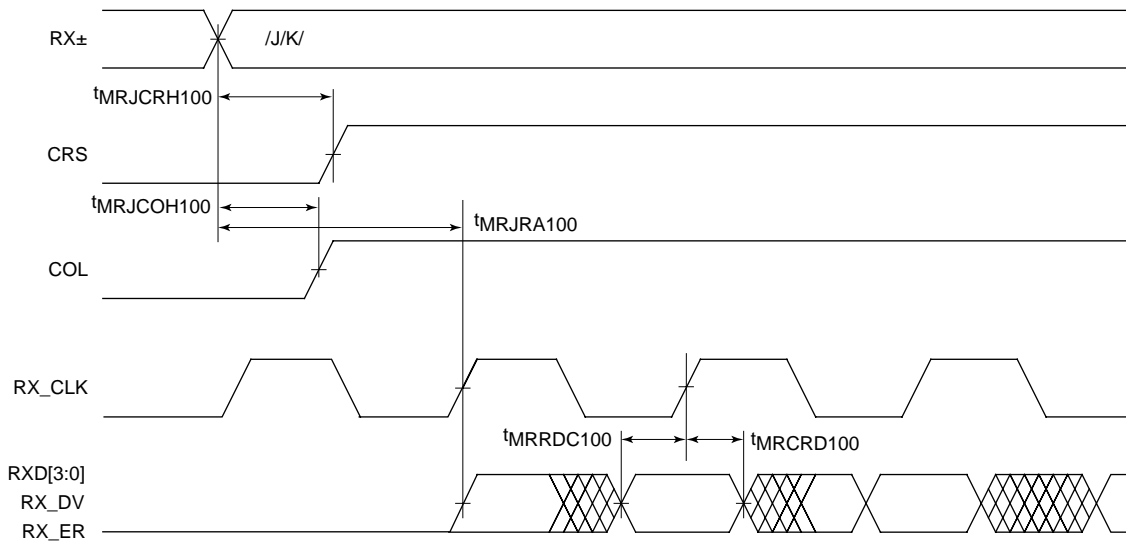

Figure 19. 100 Mbps Transmit End of Packet Timing

100 Mbps MII Receive Timing

Symbol	Parameter Description	Min.	Max.	Unit
$t_{MRJCRH100}$	CRS HIGH After First Bit of /J/	-	200	ns
$t_{MRJCOH100}$	COL HIGH After First Bit of /J/	80	150	ns
$t_{MRTCRL100}$	First Bit of /T/ to CRS LOW	130	240	ns
$t_{MRTCOL100}$	First Bit of /T/ to COL LOW	130	240	ns
$t_{MRERL100}$	First Bit of /T/ to RXD[3:0], RX_DV De-Asserting (Going LOW)	120	140	ns
$t_{MRJRA100}$	First Bit of /J/ to RXD[3:0], RX_DV, and RX_EN Active	TBD	TBD	ns
$t_{MRRDC100}$	RXD[3:0], RX_DV, RX_ER valid prior to the Rising Edge of RX_CLK	10		ns
$t_{MRCRD100}$	RXD[3:0], RX_DV, RX_ER valid after the Rising Edge of RX_CLK	10		ns



222351-22

Figure 20. 100 Mbps MII Receive Start of Packet Timing

100 Mbps MII Receive Timing (Continued)

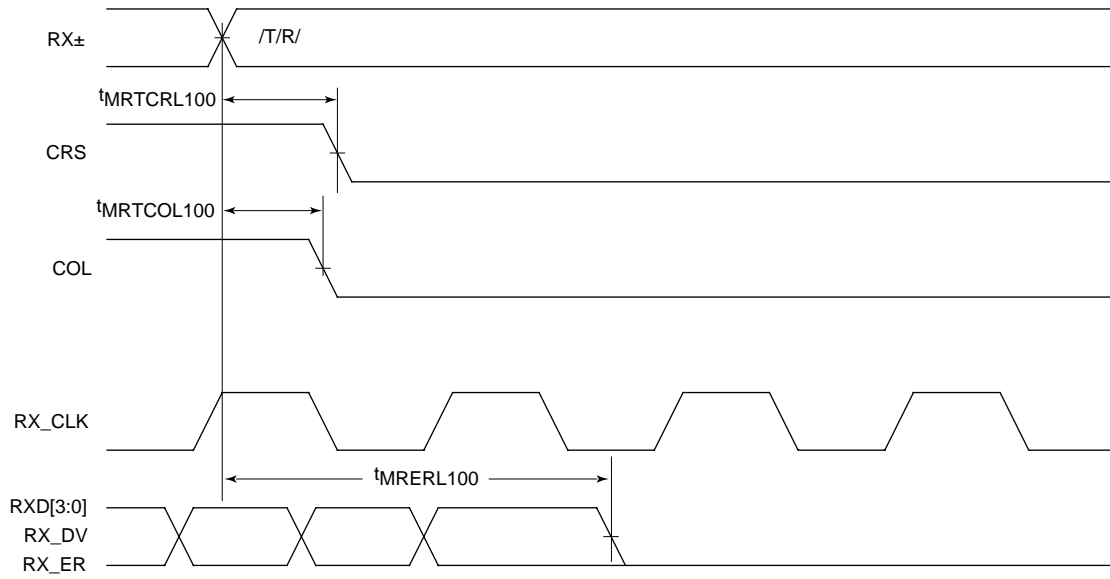

222351-23

Figure 21. 100 Mbps MII Receive End of Packet Timing

10 Mbps MII Transmit Timing

Symbol	Parameter Description	Min.	Max.	Unit
t_{MST10}	TX_EN, TXD10[3:0] Setup Time to TX_CLK Rising Edge	12	-	ns
t_{MTH10}	TX_EN, TXD10[3:0] Hold time From TX_CLK Rising Edge	0	-	ns
t_{MTEP10}	Transmit Latency TX_EN Sampled by TX_CLK to Start of Packet	240	360	ns
$t_{MTECRH10}$	CRS Assert from TX_EN Sampled HIGH	-	130	ns
$t_{MTECOH10}$	COL Assert from TX_EN Sampled HIGH	-	300	ns
$t_{MTDCRL10}$	CRS De-assert From TX_EN Sampled LOW	-	130	ns
$t_{MTDCOL10}$	COL De-assert From TX_EN Sampled LOW	-	130	ns
$t_{MTIDLE10}$	Required De-assertion Time Between Packets	300	-	ns
t_{MTP10}	TX_CLK Period	399.98	400.02	ns
t_{MTWH10}	TX_CLK HIGH	180	220	ns
t_{MTWL10}	TX_CLK LOW	180	220	ns

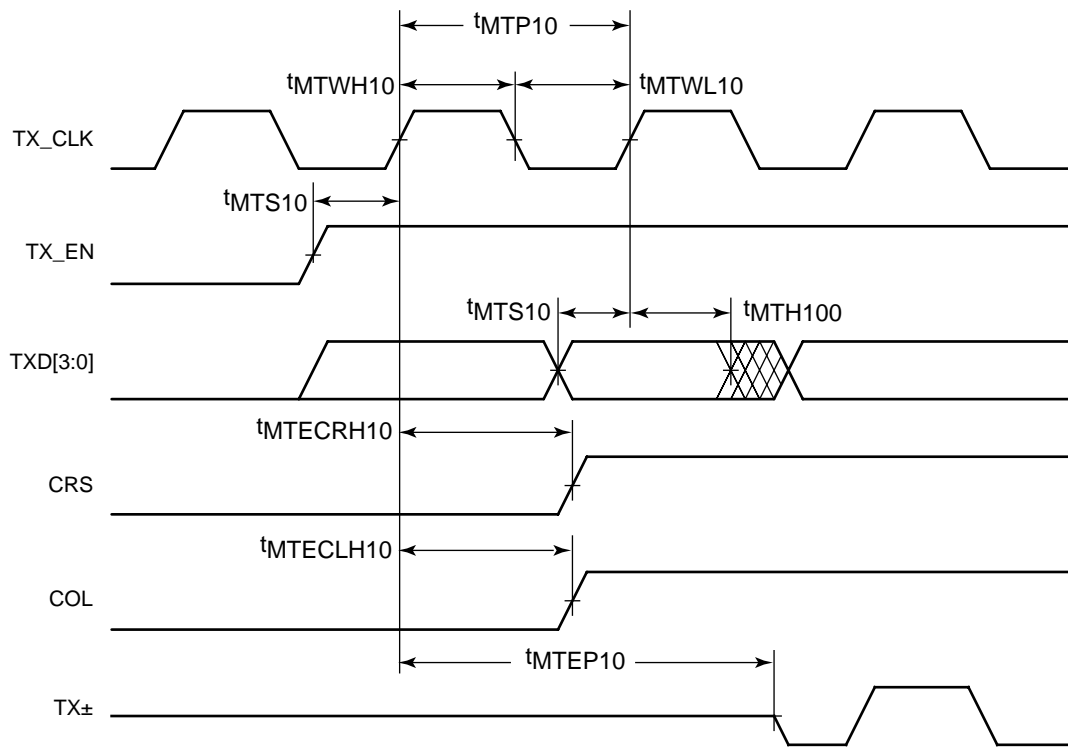

222351-24

Figure 22. 10 Mbps MII Transmit Start of Packet Timing

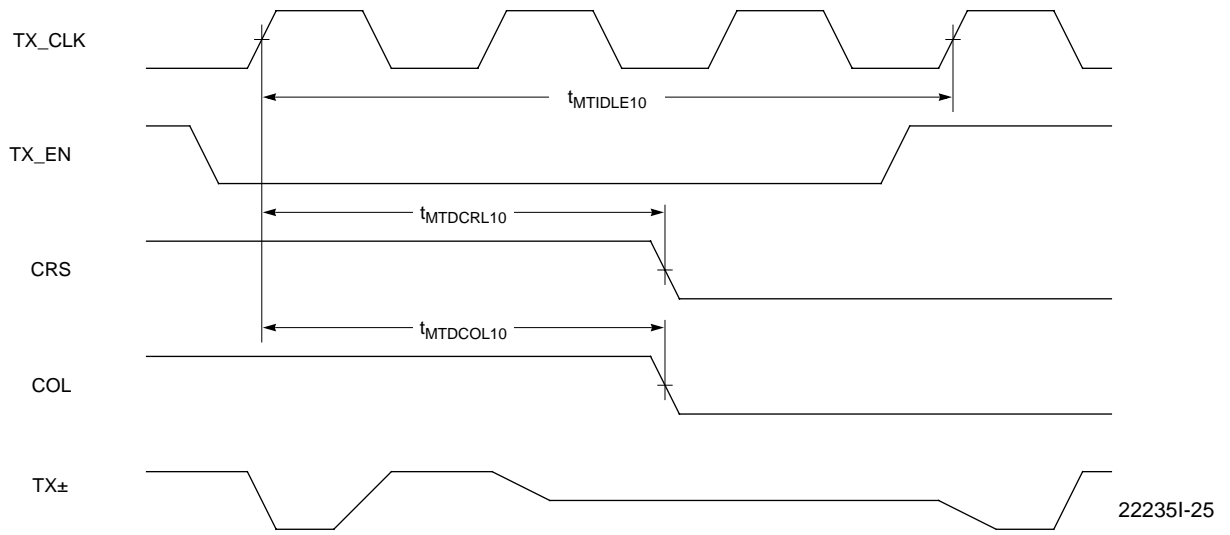
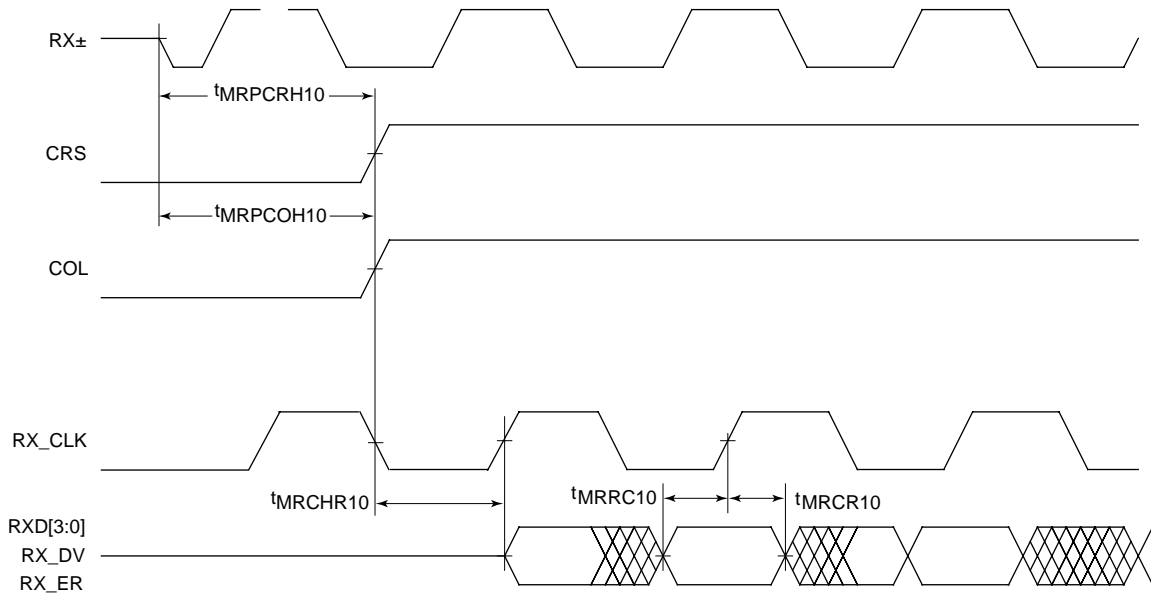

Figure 23. 10 Mbps MII Transmit End of Packet Timing

10 Mbps MII Receive Timing

Symbol	Parameter Description	Min.	Max.	Unit
$t_{MRPCR10}$	CRS HIGH After Start of Packet	80	150	ns
$t_{MRPCOH10}$	COL HIGH After Start of Packet	80	150	ns
$t_{MRCHR10}$	RXD[3:0], RX_DV, RX_ER Valid after CRS HIGH	100	100	ns
t_{MRRC10}	RXD[3:0], RX_DV, RX_ER Valid Prior to the Rising of RX_CLK10	16	-	ns
$t_{MRCRD10}$	RXD[3:0], RX_DV, RX_ER Valid After the Rising Edge of RX_CLK	12	-	ns
$t_{MRECL10}$	End of Packet to CRS LOW	130	190	ns
$t_{MRECOL10}$	End of Packet to COL LOW	125	185	ns
$t_{MRERL10}$	End of Packet to RXD[3:0], RX_DV, RX_ER De-Asserting (Going LOW)	120	140	ns



22235I-26

Figure 24. 10 Mbps MII Receive Start of Packet Timing

10 Mbps MII Receive Timing (Continued)

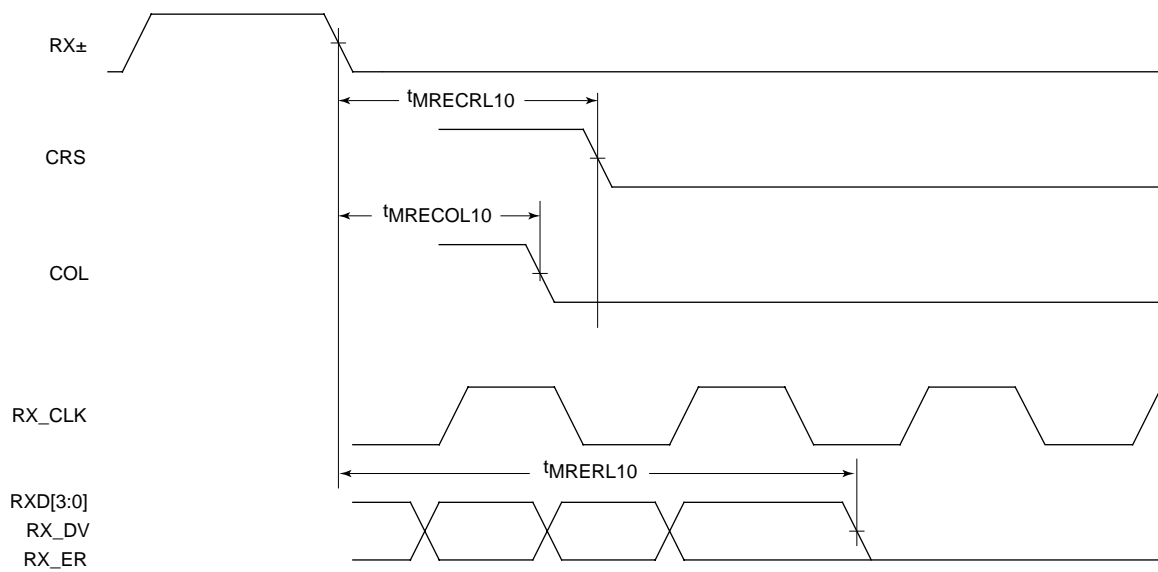

222351-27

Figure 25. 10 Mbps MII Receive End of Packet Timing

GPSI Signals

10 Mbps GPSI Receive Timing

Symbol	Parameter Description	Min.	Max.	Unit
t_{GCD}	10CRS HIGH To First Bit Of Data	750	850	ns
t_{GRCD}	Rising Edge of 10RXCLK to 10RXD or 10CRS	45	55	ns

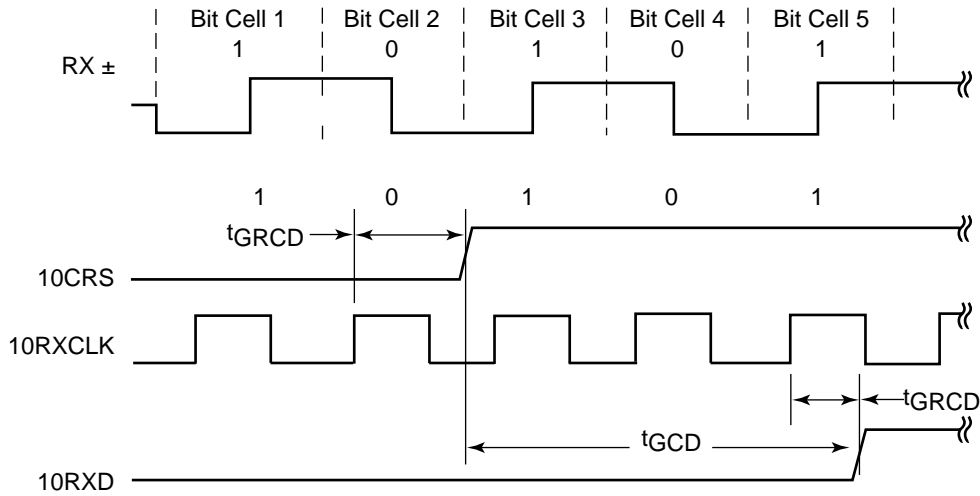

222351-28

Figure 26. GPSI Receive Timing - Start of Reception

10 Mbps GPSI Receive Timing

Symbol	Parameter Description	Min.	Max.	Unit
t_{GRCD}	Rising Edge of 10RXCLK to 10RXD or 10CRS	45	55	ns

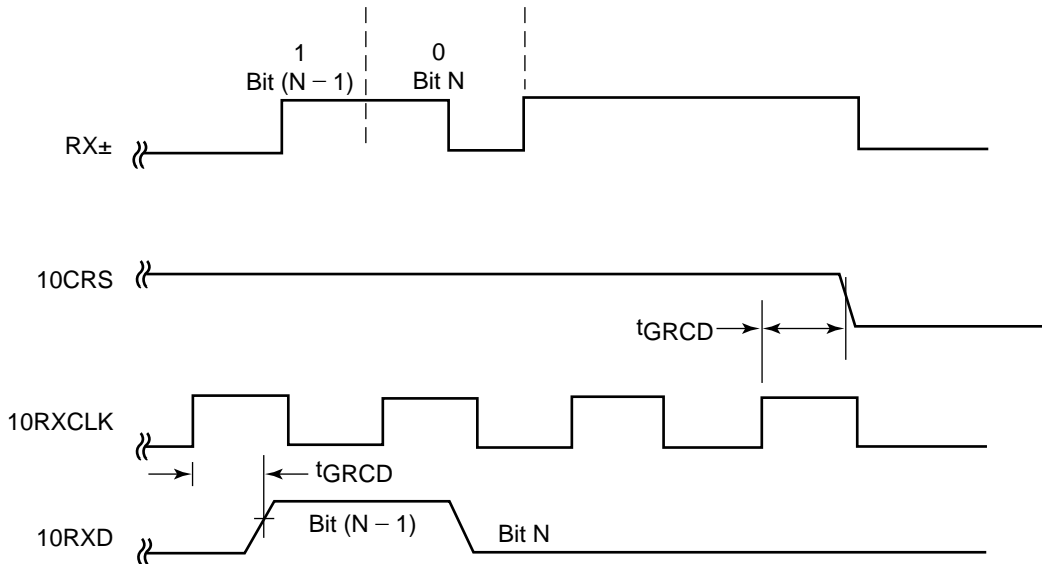

222351-29

Figure 27. GPSI Receive Timing - End of Reception (Last Bit = 0)

10 Mbps GPSI Receive Timing

Symbol	Parameter Description	Min.	Max.	Unit
t_{GDOFF}	Delay from RX_{\pm} going to 1 to the Rising Edge of 10RXCLK, which clocks out the last bit of data on 10RXD		190	ns
t_{GRCD}	Rising Edge of 10RXCLK to 10RXD or 10CRS	45	55	ns

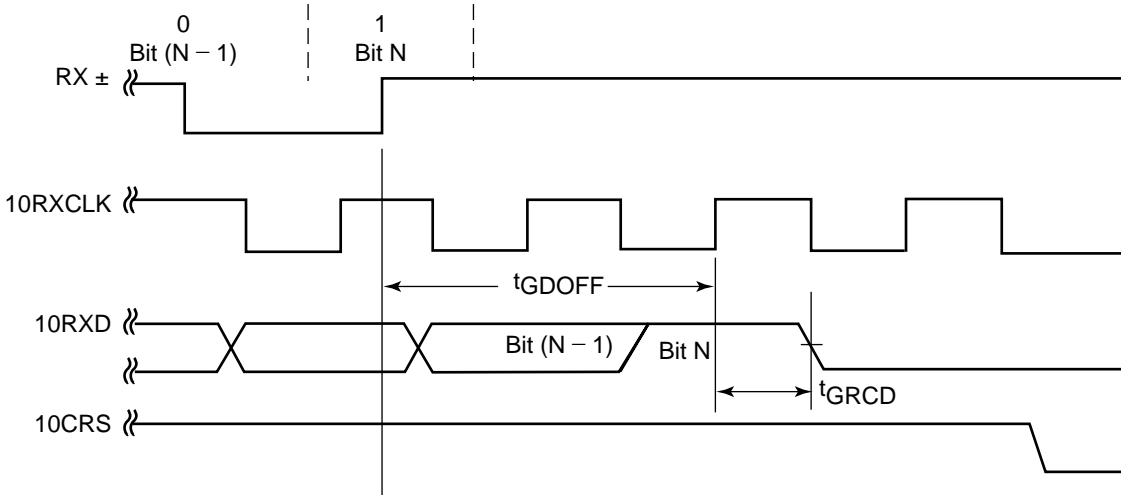

222351-30

Figure 28. GPSI Receive Timing - End of Reception (Last Bit = 1)

10 Mbps GPSI Collision Timing

Symbol	Parameter Description	Min.	Max.	Unit
$t_{GC SCLH}$	Collision Start to 10COL HIGH	80	150	ns
$t_{GC ECLL}$	Collision End to 10COL LOW	125	185	ns

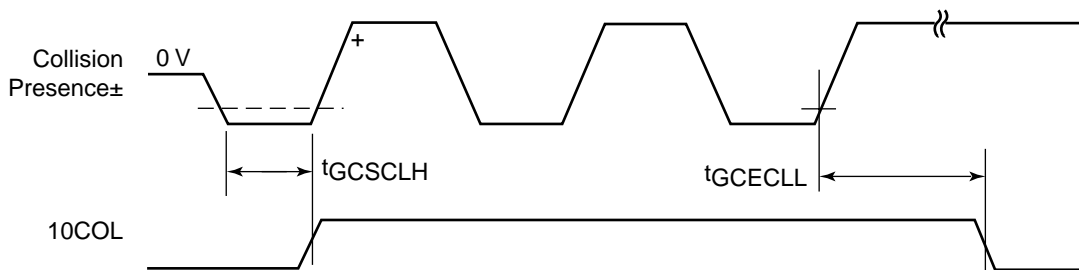

222351-31

Figure 29. GPSI Collision Timing

10 Mbps GPSI Transmit Timing

Symbol	Parameter Description	Min.	Max.	Unit
t_{GTTX}	Delay from the rising edge of the 10TXCLK which first clocks 10TXEN HIGH to TX± toggling LOW	240	360	ns

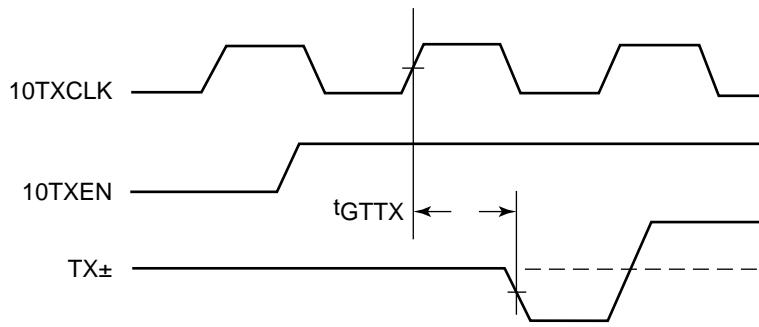

22235I-32

Figure 30. GPSI Transmit Timing - Start of Transmission

10 Mbps GPSI Transmit Timing

Symbol	Parameter Description	Min.	Max.	Unit
t_{GTCDH}	10TXCLK to 10TXD or 10TXEN Hold Time	20		ns
t_{GDTCS}	10TXD or 10TXEN to 10TXCLK Setup Time	20		ns
t_{GTCH}	10TXCLK Width HIGH	45	55	ns
t_{GTCL}	10TXCLK Width LOW	45	55	ns
t_{GTCP}	10TXCLK Period	99,995	100,005	ns

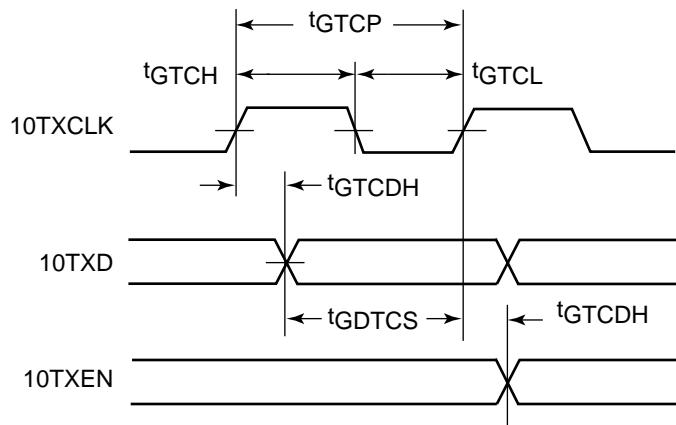

22235E-36

Figure 31. GPSI Transmit 10TXCLK and 10TXD Timing

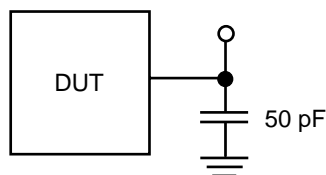

22235E-37

Figure 32. Test Load for 10RXD, 10CRS, 10RXCLK, 10TXCLK and 10COL

PHYSICAL DIMENSIONS

PQT80 (measured in millimeters)

80-Lead Thin Plastic Quad Flat Pack (PQT)

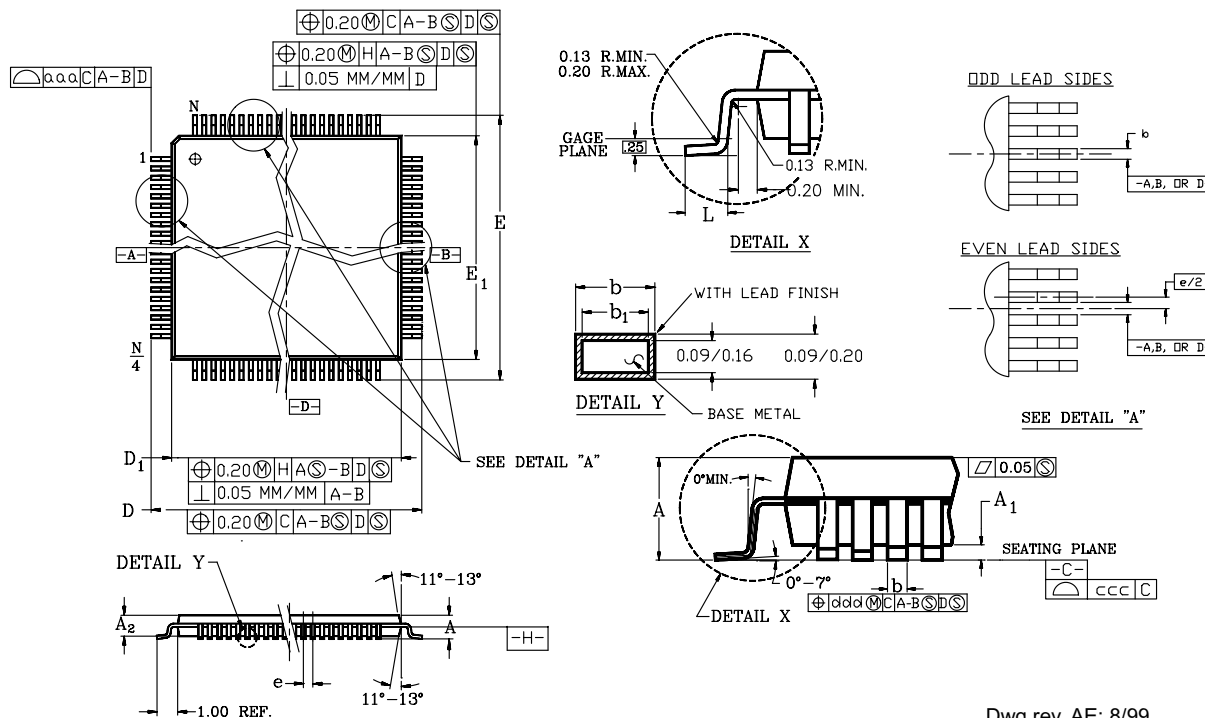

Dwg rev. AE; 8/99

PACKAGE	PQT 80		
JEDEC	MO-136 (B) AM		
SYMBOL	MIN	NOM	MAX
A	—	—	1.20
A1	0.05	—	0.15
A2	0.95	1.00	1.05
D	14.00 BSC		
D1	12.00 BSC		
E	14.00 BSC		
E1	12.00 BSC		
L	0.45	0.60	0.75
N	80		
e	0.50 BASIC		
b	0.17	0.22	0.27
b1	0.16	0.20	0.23
ccc	—	—	0.08
ddd	—	—	0.08
aaa	—	—	0.20

NOTES:

- ALL DIMENSIONS AND TOLERANCES CONFORM TO ANSI Y14.5M-1982.
- DATUM PLANE [-H-] IS LOCATED AT THE MOLD PARTING LINE AND IS COINCIDENT WITH THE BOTTOM OF THE LEAD WHERE THE LEAD EXITS THE PLASTIC BODY.
- DIMENSIONS "D1" AND "E1" DO NOT INCLUDE MOLD PROTRUSION. ALLOWABLE PROTRUSION IS 0.254mm PER SIDE. DIMENSIONS "D" AND "E" INCLUDE MOLD MISMATCH AND ARE DETERMINED AT DATUM PLANE [-H-].
- DIMENSION "B" DOES NOT INCLUDE DAMBAR PROTRUSION. ALLOWABLE DAMBAR PROTRUSION SHALL BE 0.08mm TOTAL IN EXCESS OF THE b DIMENSION AT MAXIMUM MATERIAL CONDITION. DAMBAR CAN NOT BE LOCATED ON THE LOWER RADIUS OR THE FOOT.
- CONTROLLING DIMENSIONS: MILLIMETER.
- DIMENSIONS "D" AND "E" ARE MEASURED FROM BOTH INNERMOST AND OUTERMOST POINTS.
- DEVIATION FROM LEAD-TIP TRUE POSITION SHALL BE WITHIN ±0.04 FOR PITCH ≤0.5 mm.
- LEAD COPLANARITY SHALL BE WITHIN: (REFER TO 06-500) 0.076 mm FOR DEVICES WITH LEAD PITCH OF 0.50 mm. COPLANARITY IS MEASURED PER SPECIFICATION 06-500.
- HALF SPAN (CENTER OF PACKAGE TO LEAD TIP) SHALL BE 15.30±.165 mm.
- "N" IS THE TOTAL NUMBER OF TERMINALS.
- THE TOP OF PACKAGE IS SMALLER THAN THE BOTTOM OF THE PACKAGE BY 0.15 MILLIMETERS.
- THIS OUTLINE CONFORMS TO JEDEC PUBLICATION 95 REGISTRATION MO-136, MS-026.

PQT80

REVISION SUMMARY

Revisions to other versions this document are as follows:

Revision C to D

1. Corrected reversal of Figure 4 and Figure 5 in LED section.
2. Changed ECL to PECL.

Revision D to E

1. Added GPSI timing and diagrams
2. Added Industrial Temperature support

Revision E to F

1. Minor edits

Revision F to G

1. Minor edits

Revision G to H

1. PHYAD pins: Specified using resistors in the range of 1 k Ω to 4.7 k Ω for setting PHYAD pins. In GPSI mode, PHYAD pins must be set to addresses other than 00h.
2. DC Characteristics added: V_{OLL} and V_{OHL}
3. DC Characteristics, added new values for: I_{IL} , I_{IH} , I_{OZ} . Figure 6, Advanced LED Configuration, changes to Receive LED component changes.

Revision H to I

1. Added clarification to RX_CLK throughout document, which is active only while LINK is established. See pin description for more information.
2. Added Flow Control descriptions to registers 4 and 5
3. Register 21, bit 9 was reversed: 1 selects the standard LED configuration, while 0 selects the advanced LED configuration
4. Register 21, bit 2 was changed to indicate EN_SCRM, Scrambler Enable; a 1 enables the scrambler. This register is set by the SCRAM_EN pin
5. Maximum input voltage is 5.5 V; operating voltage for 5-V tolerant pins is 5.0 V
6. Minor edits

The contents of this document are provided in connection with Advanced Micro Devices, Inc. ("AMD") products. AMD makes no representations or warranties with respect to the accuracy or completeness of the contents of this publication and reserves the right to make changes to specifications and product descriptions at any time without notice. No license, whether express, implied, arising by estoppel or otherwise, to any intellectual property rights is granted by this publication. Except as set forth in AMD's Standard Terms and Conditions of Sale, AMD assumes no liability whatsoever, and disclaims any express or implied warranty, relating to its products including, but not limited to, the implied warranty of merchantability, fitness for a particular purpose, or infringement of any intellectual property right.

AMD's products are not designed, intended, authorized or warranted for use as components in systems intended for surgical implant into the body, or in other applications intended to support or sustain life, or in any other application in which the failure of AMD's product could create a situation where personal injury, death, or severe property or environmental damage may occur. AMD reserves the right to discontinue or make changes to its products at any time without notice.

Trademarks

Copyright © 1999, 2000, 2001 Advanced Micro Devices, Inc. All rights reserved.

AMD, the AMD logo and combinations thereof, PCnet-PRO and NetPHY are trademarks of Advanced Micro Devices, Inc.

Other product names used in this publication are for identification purposes only and may be trademarks of their respective companies.

This datasheet has been downloaded from:

www.DatasheetCatalog.com

Datasheets for electronic components.



LittleDiode supplies new, hard to find or obsolete electronic components and semiconductors all over the world.

With over two million different components listed you are sure to find the part you need.

Feel free to visit us today at our online store:

LittleDiode.com

Looking forward to providing you with the best possible service.