



10Base-T/100Base-TX Integrated PHYceiver™

General Description

The **ICS1890** is a fully integrated physical layer device supporting 10 and 100Mb/s CSMA/CD Ethernet applications. DTE (adapter cards or motherboards), switching hub, repeater and router applications are fully supported. The **ICS1890** is compliant with the ISO/IEC 8802-3 Ethernet standard for 10 and 100Mb/s operation. A Media Independent Interface allowing direct chip-to-chip connection, motherboard-to-daughterboard connection or connection via an AUI-like cable is provided. A station management interface is provided to enable command information and status information exchange. The **ICS1890** interfaces directly to transmit and receive isolation transformers and can support shielded twisted pair (STP) and unshielded twisted pair (UTP) category 5 cables up to 105 meters. Operation in half duplex or full duplex modes at either 10 or 100 Mbps speeds is possible with control by Auto-Negotiation or manual selection. By employing Auto-Negotiation the technology capabilities of the remote link partner may be determined and operation automatically adjusted to the highest performance common operating mode.

Features

- One chip integrated physical layer
- All CMOS, Low power design (<200mA max)
- Small footprint 64-pin 14mm² QFP package
- ISO/IEC 8802-3 CSMA/CD compliant
- Media Independent Interface (MII)
- Alternate 100M stream and 10M 7-wire serial interfaces provided
- 10Base-TX Half & Full Duplex
- 100Base-TX Half & Full Duplex
- Fully integrated TP-PMD including Stream Cipher Scrambler, MLT-3 encoder, Adaptive Equalization, and Baseline Wander Correction Circuitry

Block Diagram

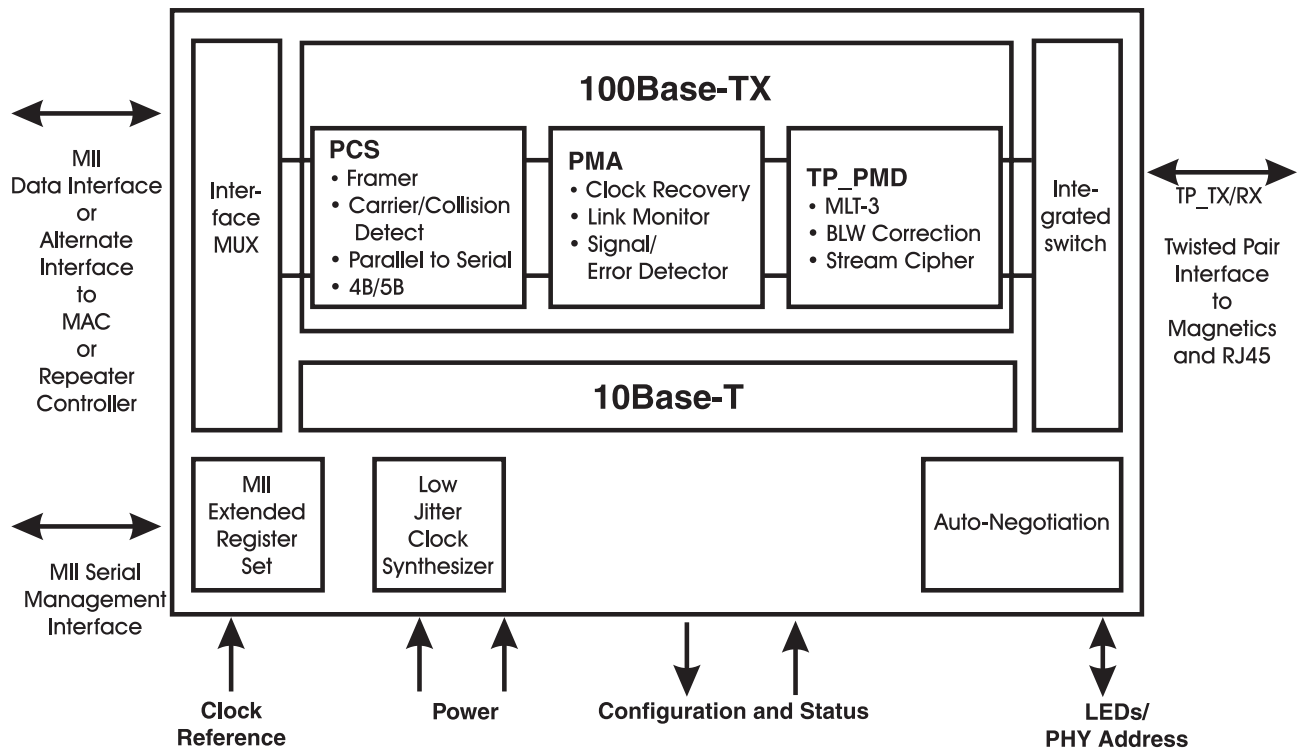

PHYceiver and QuickPoll are trademarks of Integrated Circuit Systems, Inc. Patents pending.



Modes of Operation

Reset & Basic Initialization

Reset can be accomplished using either register bit 0:15 or the RESET pin.

For a hardware reset, RESET must be held at a logic zero level for at least two clock cycles and may be held low as long as desired.

While RESET is held low the device is in Low Power mode.

After the RESET pin is released to a logic one level, Low Power mode is exited, the PHY address is latched into register 16, and the reset process continues to completion.

For a software reset, a management agent must write a logic one to register bit 0:15. This will start the reset process. The software reset bit will clear itself automatically when reset is completed.

All reset timing parameters are specified in the Electricals section of the data sheet.

Low Power and Automatic 100Base-T Power-Down

The **ICS1890** supports two power saving modes. The **ICS1890** device can be placed into a state where very little power is drawn by the device. This Low Power mode can be activated by holding the RESET pin continuously low or by writing a logic one to the Power-down bit (0:11).

When the device is in Low Power mode, all functions are disabled except for register access through the MII Management Interface.

All register values are maintained during Low Power mode, except for latching status bits, which are reset to their default values.

The **ICS1890** can also automatically reduce its total power requirements when operating in 10Base-T mode by automatically powering-down the 100Base-TX modules.

The power required by the **ICS1890** in normal, 100Base-TX power-down, and Low Power modes is given in the Electricals

section of the data sheet.

Auto-Negotiation

A link can automatically be established using Auto-Negotiation. When enabled, Auto-Negotiation will exchange information about the local node's capabilities with its remote link partner. After the information is exchanged, each device compares its capabilities with those of its partner and then the highest performance operational mode is automatically selected.

As an example, if one device supports 10Base-T and 100Base-TX, and the other device supports 100Base-TX and 100Base-T4, 100Base-TX will automatically be selected.

See the Auto-Negotiation section for more details on how the process is initiated and controlled.

100Base-TX

The primary operational mode of the **ICS1890** is to provide 100Base-TX physical layer services. This consists mainly of converting data from parallel to serial at a 100 Mb/s data rate. The device may be configured in a number of different ways and also provides detailed operational status information.

10Base-T

The **ICS1890** also provides 10Base-T physical layer services to allow easy migration from 10 to 100 Mb/s service. Complete data service is provided with configuration and status available to management.

Full Duplex

The **ICS1890** supports either half and full duplex operation for both 10Base-T and 100Base-TX. Full Duplex operation allows simultaneous transmission and reception of data which can effectively double data throughput to 20 or 200 Mb/s.

To operate in Full Duplex mode, some of the standard 10Base-T and 100Base-TX behaviors are modified.

In 10Base-T Full Duplex mode, transmitted data is not looped back to the receiver and SQE test is not performed.

In both 10Base-T and 100Base-TX Full Duplex modes, CRS is asserted in response only to receive activity and COL always remains inactive.



ICS1890

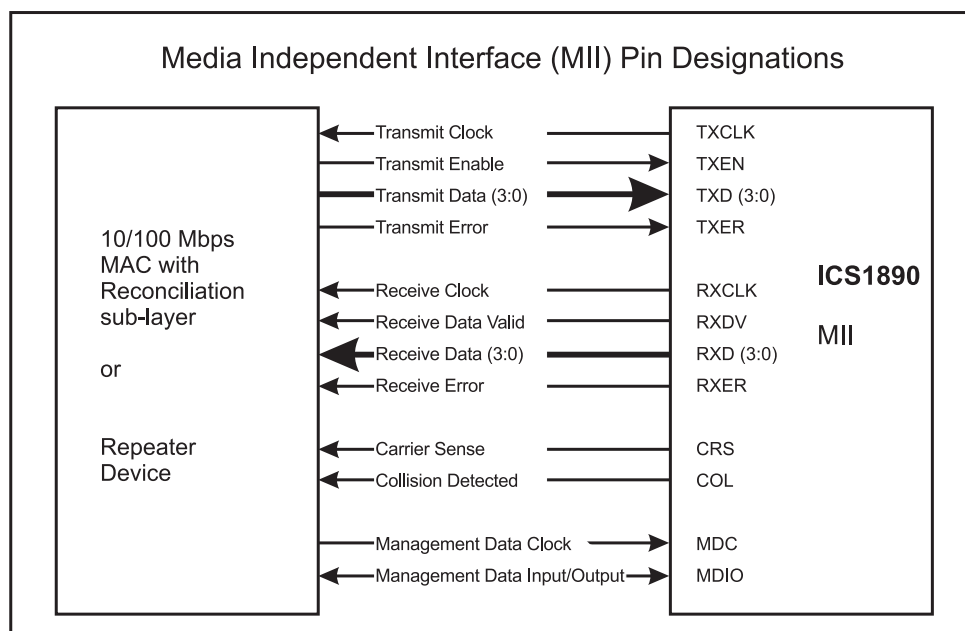

Interface Overviews

Overview of MAC/Repeater to PHY Interfaces

To accommodate different applications, the ICS1890 provides four types of MAC/Repeater to PHY interfaces. The four interfaces are - 10/100 MII Data Interface, 100M Stream Interface, 10M Serial Interface and the Link Pulse Interface.

The standard and most commonly used interface is the 10/100 MII Data Interface which provides framed 4-bit nibbles and control signals.

The 100M Stream Interface provides 5-bits of unframed data as well as the normal CRS signal which can be used as a fast look-ahead. This interface is intended for 100Base-TX repeater applications that require nothing more than recovered parallel data where all framing is handled in the repeater core logic.

The 10M Serial Interface provides a framed single data bit interface with control signals and is ideally suited to applications that already incorporate a serial 10Base-T MAC with a standard "7-wire" interface.

The Link Pulse Interface is provided for applications that wish to fully control the Auto-Negotiation process themselves but not the actual generation and reception of Link Pulses.

MII Data Interface

The ICS1890 implements a fully compliant IEEE 802.3u Media Independent Interface for connection to MACs or repeaters allowing connection between the ICS1890 and MAC on the same board, motherboard/daughter board or via a cable in a similar manner to AUI connections.

The MII is a specification of signals and protocols which formalizes the interfacing of a 10/100 Mbps Ethernet Media Access Controller (MAC) to the underlying physical layer. The specification is such that different physical media may be supported (such as 100Base-TX, 100Base-T4 and 100Base-FX) transparently to the MAC.

The MII Data Interface specifies transmit and receive data paths. Each path is 4-bits wide allowing for transmission of a data nibble. The transmit data path includes a transmit clock for synchronous transfer, a transmit enable signal and a transmit error signal. The receive data path includes a receive data clock for synchronous transfer, a receive data valid signal and a receive error signal. Both the transmit clock and receive clock are sourced by the ICS1890.

The ICS1890 provides the MII signals carrier sense and collision detect. In half duplex mode, carrier sense indicates that data is being transmitted or received, and in full duplex mode it indicates that data is being received. Collision detect indicates that data has been received while a transmission is in progress.



The **ICS1890** is designed to allow hot insertion of an MII cable into a MAC MII port. During the power-up phase, the **ICS1890** will isolate the MII and the Twisted Pair Transmit signal pair

100M Stream Interface

The 100M Stream Interface is an alternative parallel interface between the PHY and MAC/Repeater than the standard MII Data interface. The Stream Interface provides a lower level interface and, therefore, lower bit delay than the standard MII Data Interface.

This interface is selected by setting the MII/SI pin to STREAM INTERFACE mode and by setting the 10/100SEL pin to 100 mode.

The Stream Interface bypasses the Physical Coding Sublayer (PCS) and provides a direct unscrambled, unframed 5-bit interface to the Physical Media Access (PMA) layer.

The Stream Interface consists of a 14 signal interface: STCLK, STD[4:0], SRCLK, SRD[4:0], SCRS, SD.

Data is exchanged between the MAC and PHY using 5-bit unframed code groups at 25 MHz clock rate.

The Stream Interface provides a CRS signal by continuing to use the logic that is bypassed by this interface. This gives a carrier indication faster than is possible from the MAC/Repeater since the bits are examined serially as soon as they enter the PHY.

Since only the Stream Interface or the MII Interface is active at once, it is possible to share the MII Data interface pins for Stream Interface functionality.

The pins have the following mapping:

<u>MII</u>	<u>Stream</u>
TXCLK	STCLK
TXEN	(1)
TXER	STD4
TXD3	STD3
TXD2	STD2
TXD1	STD1
TXD0	STD0
RXCLK	SRCLK
RXDV	(2)
RXER	SRD4
RXD3	SRD3
RXD2	SRD2
RXD1	SRD1
RXD0	SRD0
CRS	SCRS
COL	(3)
LSTA	SD

(1) 100Base-TX is a continuous transmission system and the MAC/Repeater is responsible for sourcing IDLE symbols when it is not transmitting data when using the Stream Interface.

(2) Since data is not framed when this interface is used, RXDV has no meaning.

(3) Since the MAC/Repeater is responsible for sourcing both active and idle data, the PHY can not tell when it is transmitting in the traditional sense, so no collisions can be detected. Other mode configuration pins behave identically regardless of which data interface is used.



ICS1890

10M Serial Interface

The 10M Serial Interface is an alternative serial interface between the PHY and MAC/Repeater than the standard MII Data interface. The 10M Serial interface provides the same functionality, but with a serial data stream at a 10 MHz clock rate.

This interface is selected by setting the MII/SI pin to STREAM INTERFACE mode and by setting the 10/100SEL pin to 10 mode.

The 10M Serial Interface operation consists of a nine signal interface: 10TCLK, 10TXEN, 10TD 10RCLK, 10RXDV, 10RD, 10CRS, 10COL, and LSTA.

Data is exchanged between the MAC and PHY serially at a 10 MHz clock rate.

Since only the 10M Serial Interface or the MII Interface is active at once, it is possible to share the MII Data interface pins for 10M Serial Interface functionality.

The pins have the following mapping:

<u>MII</u>	<u>10M Serial</u>
TXCLK	10TCLK
TXEN	10TXEN
TXER	(1)
TXD3	
TXD2	
TXD1	
TXD0	10TD
RXCLK	10RCLK
RXDV	10RXDV
RXER	(1)
RXD3	
RXD2	
RXD1	
RXD0	10RD
CRS	10CRS
COL	10COL
LSTA	LSTA

(1) Error generation and detection is not supported by 10Base-T.

Other mode configuration pins behave identically regardless of which data interface is used.

Link Pulse Interface

The Link Pulse Interface is an alternative control interface between the PHY and MAC/Repeater than the standard MII Data interface. The Link Pulse provides detailed control over the Auto-Negotiation process.

This interface is selected by setting the MII/SI pin to STREAM INTERFACE mode, by setting the 10/100SEL pin to 10 mode, and by setting the 10/LP pin to LP mode.

The Link Pulse Interface consists of a five signal interface: LTCLK, LPTX, LRCLK, LPRX, SD.

Since only the Link Pulse Interface or the MII Interface is active at once, it is possible to share the MII Data interface pins for Link Pulse Interface functionality.

The pins have the following mapping:

<u>MII</u>	<u>Link Pulse</u>
TXCLK	LTCLK
TXEN	
TXER	LPTX
TXD3	
TXD2	
TXD1	
TXD0	
RXCLK	LRCLK
RXDV	
RXER	LPRX
RXD3	
RXD2	
RXD1	
RXD0	
CRS	
COL	
LSTA	SD

Other mode configuration pins behave identically regardless of which data interface is used.



MII Management Interface

The MII also specifies a two-wire management interface and a protocol between station management and the physical layer. The **ICS1890** implements this interface, providing a bidirectional data line and a clock input for synchronizing the data transfers. This interface allows station management to read from and write to all of the device's registers.

Twisted Pair Interface

The **ICS1890** is able to operate in either 10Base-T or 100Base-TX modes using a shared interface to a universal magnetics module and single RJ-45 connector jack.

The interface signals consist of a differential pair of transmit signals and a differential pair of receive signals. The interface also provides pins for setting the 10 & 100M transmit current.

Clock Reference Interface

The **ICS1890** synthesizes all its required clock signals from a single 25MHz frequency reference supplied to the Clock Reference Interface (REF_IN & REF_OUT).

Any reference must meet the stringent IEEE standard requirements for total accuracy under all conditions of ± 50 parts per million (ppm), even though the device can easily function with a less accurate reference.

Three reference configurations are supported.

A simple CMOS level signal may be fed into the REF_IN input, leaving the REF-output unconnected.

A crystal oscillator module may be used to provide the frequency reference for the REF_IN input instead of simple reference.

It is possible to use a high precision crystal between the REF_IN and REF_OUT pins on the ICS1890 to provide the 25MHz time base for part operation. In addition to the connection of the crystal between these pins, a capacitor from REF_IN and REF_OUT to ground is necessary to neutralize the capacitance of the crystal. Since these capacitors are nominally in series, the values of each of these components (plus stray board capacitance) will equal twice the rated capacitance of the crystal (series combination).

It is imperative that the crystal be cut for accuracy and temperature coefficients with the equivalent capacitive loading of the specific board layout and the chosen neutralizing capacitors. The overall accuracy for ethernet applications must be ± 50 ppm total for accuracy, temperature, and aging. Therefore the crystal must be cut using a fixture with the equivalent capacitive loading as in the end application. This custom "cutting" of the crystal will be at additional cost, but in high volume applications this may be cost effective compared to "pretuned" crystal oscillator modules. For more information, contact ICS Datacom Applications.

Configuration and Status Interface

This interface provides a full set of pins to allow the device to be completely configured by hardware.

The interface also provides dynamic tristate control over both the Twisted Pair Transmit interface and the MII Receive interface.

Link Status and Stream Cipher Locking status signals are provided for use by a MAC or custom logic.

PHY Address & LED Interface

The **ICS1890** device uses a unique scheme to multiplex the PHY Address and the LED outputs onto the same set of five pins.

Simply connecting the LED from the device pin to either power or ground sets the address bit to a 1 or 0. The device then uses the address info to drive the LED correctly independent of its connection. The Pin Description section provides detailed connection instructions.



ICS1890

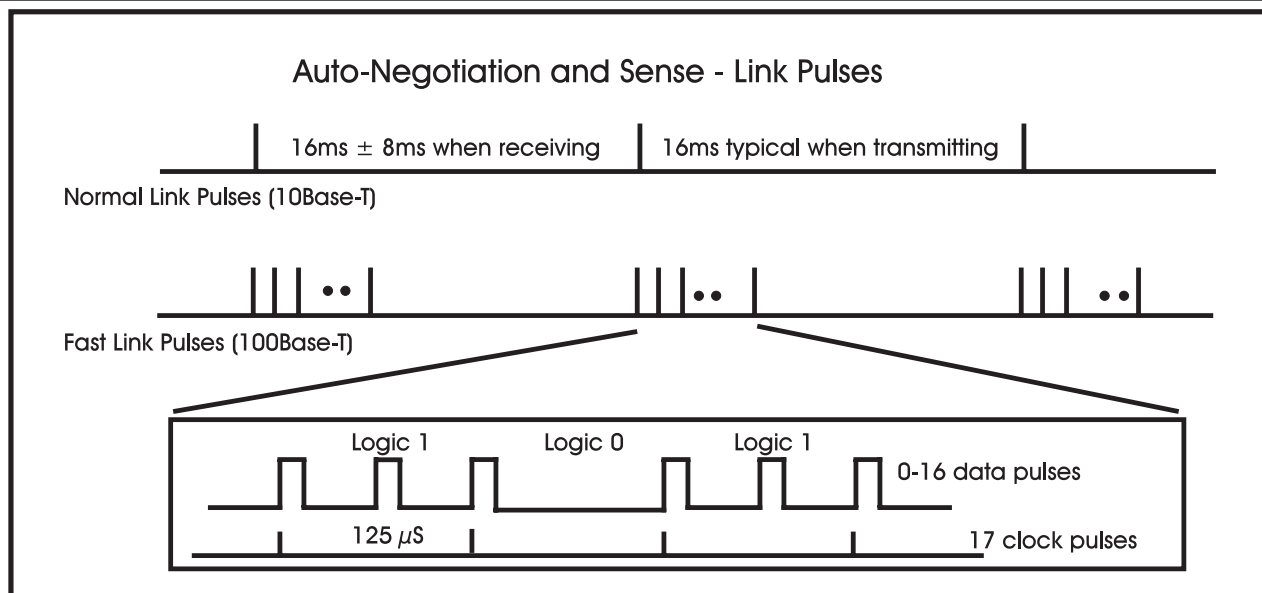

Functional Blocks

Media Independent Interface (MII) Overview

The MII consists of a data interface, basic register set, and a serial management interface to the register set.

The data interface is a nibble wide transmit and receive data interface between the MAC and PHY devices. The interface supports data transfers at 25 MHz for 100Base-T and 2.5 MHz for 10Base-T.

The register set consists of basic and extended standard registers as well as vendor specific registers. There are two basic registers, a control register to handle basic device configuration, and a status register to report basic device abilities and status. The standard extended registers provide access to an Organizationally Unique Identifier and Auto-Negotiation functionality.

The **ICS1890** also provides vendor specific registers that enhance the device operation. Among these is the QuickPoll Detailed Status register which provides a comprehensive set of real-time device information with only single register access.

Auto-Negotiation

The auto-negotiation logic of the **ICS1890** has three main purposes. Firstly, to determine the capabilities of the remote partner (device at the other end of the cable). Secondly, to advertise its own capabilities to the remote partner. And thirdly, to establish a connection with the remote partner using the highest performance common connection technology.

The **ICS1890** auto-negotiation logic is designed to operate with legacy 10Base-T networks or newer systems with multiple connection technology options. When operating with a legacy 10Base-T remote partner, the **ICS1890** will select the 10Base-T operating mode transparently to the remote partner thus allowing the preservation of existing legacy network structures without management intervention.

Auto-negotiation is accomplished using a physical signaling scheme that is transparent at the packet and higher level protocols. This scheme builds upon the 10Base-T link test pulse sequence by using a burst of pulses to signal configuration information between the two devices.

The Fast Link Pulse Bursts are simultaneously exchanged by both nodes on a link segment the local node encodes the data from the Auto-negotiation Advertisement Register (register 4) into the FLP Bursts it transmits. The data received from the link partner's FLP Bursts is placed into the Auto-Negotiation Link Partner Ability Register (register 5). When Auto-Negotiation is complete (1:5=1 or 17:4=1), the highest priority technology from the following table that is common in the two registers is automatically selected as the operating mode.

Priority Resolution Table
Highest Priority Listed first.

- 1) 100Base-TX Full Duplex
- 2) 100Base-T4
- 3) 100Base-TX
- 4) 10Base-T Full Duplex
- 5) 10Base-T



Status	Progress Monitor Status Bits			
	A-N Complete	Bit 2	Bit 1	Bit 0
Idle	0	0	0	0
Parallel Detected	0	0	0	1
Parallel Detection Failure	0	0	1	0
Ability Matched	0	0	1	1
Acknowledge Match Failure	0	1	0	0
Acknowledge Matched	0	1	0	1
Consistency Match Failure	0	1	1	0
Consistency Matched	0	1	1	1
Auto-Negotiation Completed Successfully	1	1	1	1

In the event that the link partner does not support auto-negotiation, backward compatibility is guaranteed because legacy systems will not respond to the burst (called Fast Link Pulses). 10Base-T systems will continue to send 10Base-T link test pulses which will be interpreted by the ICS1890 as a 10Base-T technology only device. 100Base-TX systems would send scrambled idle symbols, which would be interpreted by the ICS1890 as a 100Base-TX only device. Auto-negotiation is invoked at power-up, upon request by management, or manually.

Auto-Negotiation Progress Monitor

Under normal circumstances, Auto-Negotiation is able to effortlessly establish a connection with the link partner. There are, however, some situations that may prevent Auto-Negotiation from completing properly. The Auto-Negotiation Progress Monitor is designed to provide detailed information to a station management entity to assist it in making a connection in the event that Auto-Negotiation is unable to establish a connection by itself.

During normal Auto-Negotiation operation, the device exchanges capability information with its link partner and then sets the Auto-Negotiation Complete bit in the Status register (1:5) (also available in the QuickPoll register as bit 17:4) to a logic one to indicate that the information exchange has completed successfully and that Auto-Negotiation has handed off the link startup process to the negotiated technology.

Auto-Negotiation can also accommodate legacy 10Base-T and 100Base-TX link partners that do not have Auto-Negotiation capability. In this case, Auto-Negotiation identifies the link partner as not being Auto-Negotiation able by setting the LP_AutoNeg_Able bit (6:0) to a logic zero, identifies the legacy connection to be made by setting the single bit corresponding to that technology in the AN Link Partner Abilities Register (either bit 5:7 or 5:5), and finally indicates Auto-Negotiation Complete.

The entire process, in either case, usually takes less than half a second to complete. Typically, management will poll the Auto-Negotiation Complete bit and then the Link Status bit to determine when a connection has been successfully made and then the actual type of connection can be determined by management. This information is all contained in the QuickPoll register.

When Auto-Negotiation fails, Auto-Negotiation Complete may never become true or Link Status may never become good. Station management can detect this condition and discover why there is a failure to connect by using the detailed information provided by the Auto-Negotiation Progress Monitor.

The Auto-Negotiation Progress Monitor provides four bits of status in the QuickPoll Detailed Status register when combined with the already present Auto-Negotiation Complete bit.

As progress is made through the Auto-Negotiation Arbitration state machine, higher status values are locked in to the progress monitor. The status value only is allowed to increase until either Auto-Negotiation is completed successfully or the progress monitor status is read by management.

After the status is read by management, the status is reset to the current status of the Arbitration state machine. After negotiation has completed successfully, any link failure will cause the process to being anew.

This behavior allows management to always determine the greatest forward progress made by the Auto-Negotiation logic.



ICS1890

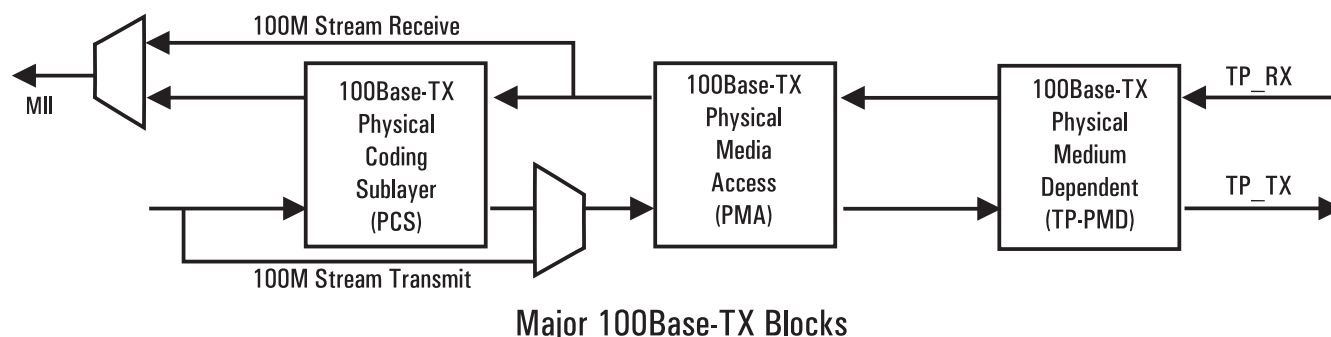

Major 100Base-TX Blocks

100Base-TX Physical Coding Sublayer [PCS]

Carrier Detector & Framer

The carrier detector examines the serial bit stream looking for the SSD, the “JK” symbol pair. In the idle state, IDLE symbols (all logic ones) will be received. If the carrier detector detects a logic zero in the bit stream, it examines the following bits looking for the first two non-contiguous zeros, confirms that the first 5-bits form the “J” symbol (11000) and asserts carrier detect. At this point the serial data is framed and the second symbol is checked to confirm the “K” symbol (10001). If successful, the following framed data (symbols) are presented to the 4B5B decoder. If the “JK” pair is not confirmed, the false carrier detect is asserted and the idle state is re-entered.

Collision Detector Collision is asserted in half-duplex mode when transmission and data reception occur simultaneously. In full duplex mode, collision is never asserted.

Parallel/Serial Converter

This block converts data between 5-bit symbols and 1-bit serial data.

4B/5B Encoder/Decoder

When the ICS1890 is operating in the 100Base-TX mode, 4B5B coding is used. This coding scheme maps a 4-bit nibble to a 5-bit code group. Since this gives 32 possible symbols and the data only requires 16 symbols, 16 symbols are designated control or invalid. The control symbols used are “JK” as the start-of-stream delimiter (SSD), “TR” as the end-of-stream delimiter (ESD), “I” as the IDLE symbol and “H” to signal an error. All other symbols are invalid and, if detected, will set the receive error bit in the status register.

When transmitting, nibbles from the MII are converted to 5-bit code groups. The first 16 nibbles obtained from the MII are the MAC frame preamble. The ICS1890 replaces the first two nibbles with the start-of-stream delimiter (the “JK” symbol pair). Following the last nibble, the ICS1890 adds the end-of-stream delimiter (the “TR” symbol pair).

When receiving, 5-bit code groups are converted to nibbles and presented to the MII. If the ICS1890 detects one or more invalid symbols, it sets the receive error bit in the status register. When receiving a frame, the first two 5-bit code groups received are the start-of-stream delimiter (the “JK” symbol pair), the ICS1890 strips them and substitutes two nibbles of the normal preamble pattern. The last two 5-bit code groups are the end-of-stream delimiter (the “TR” symbol group), these are stripped from the nibbles presented to the MAC.



4B5B Encoding (including invalid test mode coding)

Symbol	Meaning	4B Code 3210	5B Code 43210
0	Data 0	0000	11110
1	Data 1	0001	01001
2	Data 2	0010	10100
3	Data 3	0011	10101
4	Data 4	0100	01010
5	Data 5	0101	01011
6	Data 6	0110	01110
7	Data 7	0111	01111
I	Idle	undefined	11111
J	SSD	0101	11000
K	SSD	0101	10001
T	ESD	undefined	01101
R	ESD	undefined	00111
H	Error	undefined	00100
V	Invalid	undefined	00000
V	Invalid	undefined	00001

Symbol	Meaning	4B Code 3210	5B Code 43210
8	Data 8	1000	10010
9	Data 9	1001	10011
A	Data A	1010	10110
B	Data B	1011	10111
C	Data C	1100	11010
D	Data D	1101	11011
E	Data E	1110	11100
F	Data F	1111	11101
V	Invalid	undefined	00010
V	Invalid	undefined	00011
V	Invalid	undefined	00101
V	Invalid	undefined	00110
V	Invalid	undefined	01000
V	Invalid	undefined	01100
V	Invalid	undefined	10000
V(S)	Invalid	undefined	11001

Invalid Error Code Test (TXER asserted)

I	Idle	1 1 1 1	1 1 1 1 1
J	SSD	1 1 1 0	1 1 0 0 0
K	SSD	1 0 1 1	1 0 0 0 1
T	ESD	1 0 0 1	0 1 1 0 1
R	ESD	0 1 1 1	0 0 1 1 1
H	Error	0 1 0 0	0 0 1 0 0
V	Invalid	0 0 0 0	0 0 0 0 0
V	Invalid	0 0 0 1	0 0 0 0 1

V	Invalid	0 0 1 0	0 0 0 1 0
V	Invalid	0 0 1 1	0 0 0 1 1
V	Invalid	0 1 0 1	0 0 1 0 1
V	Invalid	0 1 1 0	0 0 1 1 0
V	Invalid	1 0 0 0	0 1 0 0 0
V	Invalid	1 0 1 0	0 1 1 0 0
V	Invalid	1 1 0 0	1 0 0 0 0
V(S)	Invalid	1 1 0 1	1 1 0 0 1



ICS1890

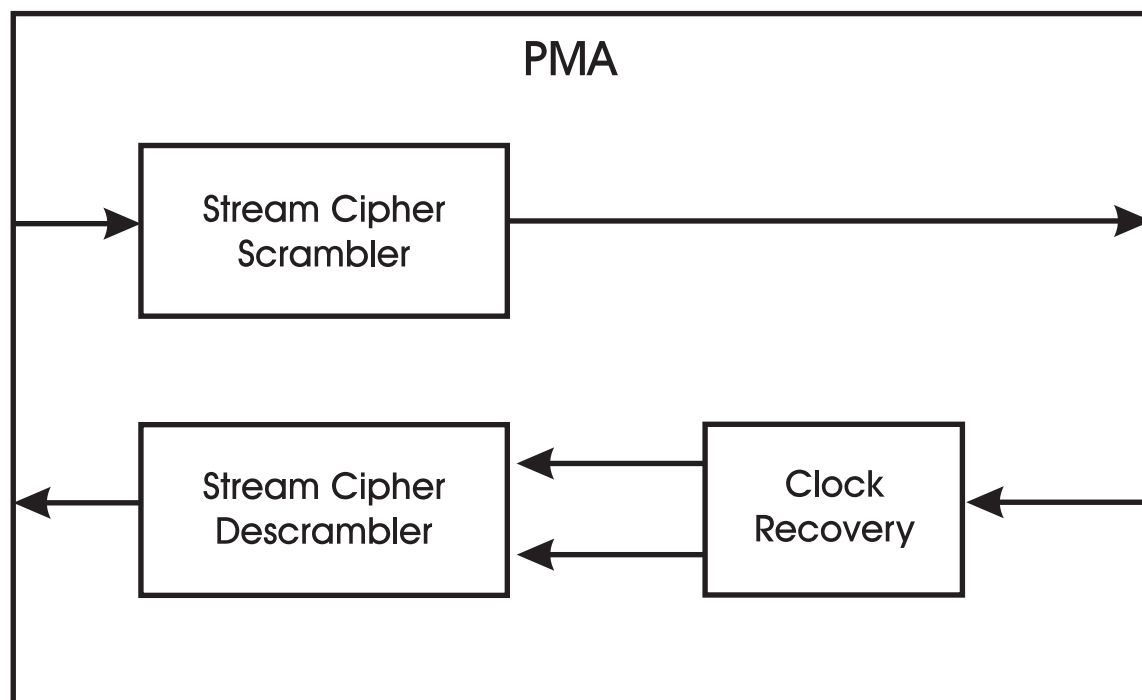

100Base-T Physical Media Access [PMA]

Clock Recovery

The Clock Recovery block locks onto the incoming data stream, extracts the embedded clock, and presents the data synchronized to the recovered clock. This process produces signals with very low timing uncertainty and noise (jitter).

In the event that the PLL is unable to lock on to the receive signal, it generates a “not locked signal.” The transmit clock synthesizer provides a center frequency reference for operation of the clock recovery circuit in the absence of data. The “receive signal detected” and “not locked” signals are both used by the logic which monitors the receive channel for errors.

Transmit Clock Synthesizer

The ICS1890 synthesizes the transmit clock using a PLL to produce 2.5 MHz for 10Base-T and 25 MHz for 100Base-TX. Internal clock frequencies of 20 MHz and 125 MHz are also generated. This allows the use of a low cost 25 MHz crystal oscillator for a low jitter reference frequency.

Signal Detector

The ICS1890 Signal Detector is part of the clock recovery PLL. It detects a Receive Signal Error if no receive signal is received and detects a PLL Lock Error if the PLL is unable to lock on to the receive channel signal. A receive channel error is defined as the loss of receive signal or the loss of PLL lock.

Remote Fault Signaling Remote fault signaling allows a link partner to signal receive channel errors on its transmit channel. It is then possible to establish the integrity of both the transmit and receive channels. If auto-negotiation is enabled, the ICS1890 monitors the receive channel for Fast Link Pulses or Normal Link Pulses. If an error is detected, the remote error condition is signaled.

The ICS1890 is able to report a remote fault detected by its link partner. When the link partner is an ICS1890, a remote fault will be signaled when it detects a receive signal error. The definition of a remote fault for a non-ICS1890 link partner is undefined, but generally will mean that there is a problem with the integrity of the link partner’s receive channel.

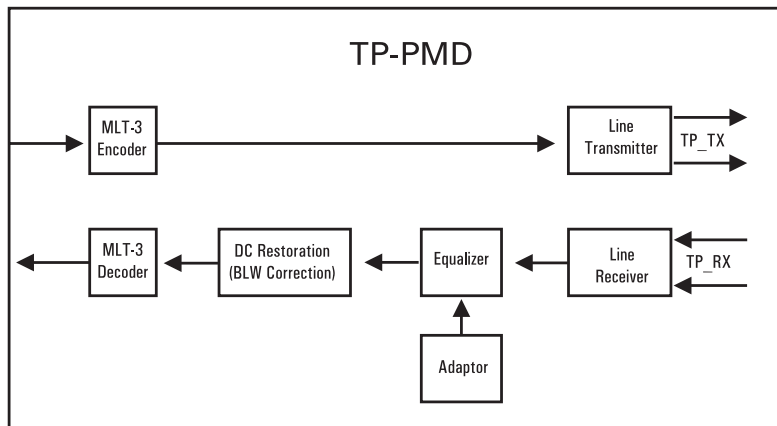

*100Base-T Twisted Pair Physical Media
Dependent [TP-PMD]*

Stream Cipher Scrambler/Descrambler

When the **ICS1890** is operating in the 100Base-TX mode, a stream cipher scrambler/descrambler that conforms to the ANSI Standard X3T9.5 FDDI TP-PMD is employed. The purpose of the stream cipher scrambler is to randomize the 100 Mbps data on transmission resulting in a reduction of the peak amplitudes in the frequency spectrum. The stream cipher descrambler restores the received 5-bit code groups to their unscrambled values. The stream cipher scrambler/descrambler is bypassed in the 100M stream interface mode.

MLT-3 Encoder/Decoder

When the **ICS1890** is operating in the 100Base-TX mode, an MLT-3 encoder and decoder is employed. The encoder converts the NRZI transmitted bit stream to a three-level code resulting in a reduction in the energy over the critical frequency range of 20MHz to 100MHz. The MLT-3 decoder converts the received three-level code back to an NRZI bit stream.

DC Restoration

The 100Base-TX specification uses a stream cipher scrambler to minimize peak amplitudes in the frequency spectrum. However, the nature of the stream cipher and MLT-3 encoding is such that long run lengths of zeroes and ones can cause the production of a DC component. This DC component cannot be transmitted through the isolation transformers and results in baseline wander. Baseline wander decreases noise immunity since the base-line moves closer to either the positive or negative signal comparaters. Figure 1 is an exaggerated simulation of the effect of baseline wander (the time period would normally be much longer).

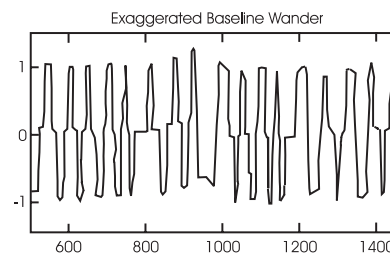

Figure 1

The **ICS1890** uses DC restoration to restore the lost DC component of the recovered digital data thus correcting for baseline wander.

Adaptive Equalizer

The **ICS1890** includes an adaptive equalizer to compensate for signal amplitude and phase distortion incurred from the transmission media. Signal equalization will actively occur for twisted pair cable lengths of up to 105 meters.

At a data rate of 100 Mbps, the cable introduces significant signal distortion due to high frequency roll off and phase shift. The high frequency loss is mainly due to skin-effect which causes the conductor resistance to rise as the square of the frequency (see Figure 2).

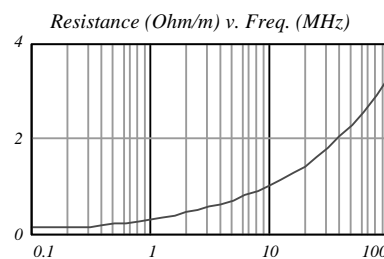

Figure 2



ICS1890

Typical and worst case frequency response for 100 meters (worst case length as derived from draft standard EIA/TIA-568- A) of UTP Category 5 cable is shown in Figure 3.

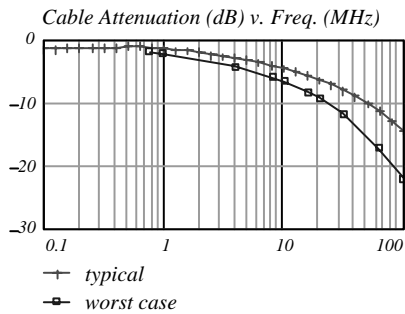

Figure 3

The pulse shape of the received signal is critical for MLT-3 encoded data since there are three distinct levels to resolve in order to properly recover the data. Figure 4 shows the typical signal at the input and output ends of 100 meters of UTP Category 5 cable.

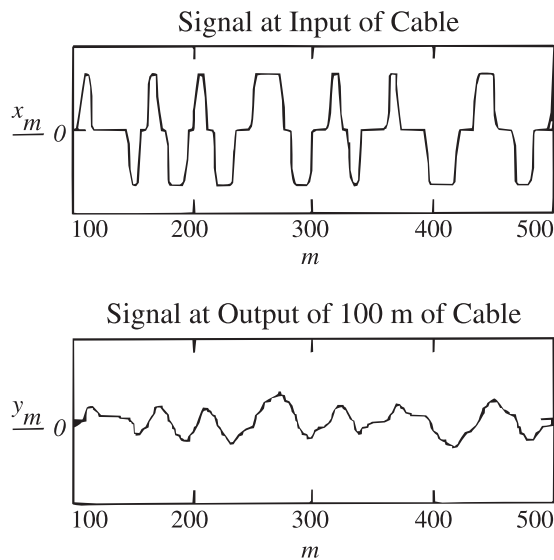

Figure 4

Since the cable length that must be equalized can be anything from 0 to 105 meters, the optimum equalization cannot be fixed, but must depend on cable length. Thus, adaptive equalization must be applied at the receive end to restore the signal.

The adaptive equalization process consists of applying increasing amounts of phase and gain correction while monitoring the integrity of the recovered data. The adaptive equalizer picks the best of 32 equalization settings and “Fixes” this value into the equalization register. This setting provides the best recovery of the transmitted data with lowest Bit Error Rate (BER).

Line Transmitter The line transmitter logic of the ICS1890 is a current-driven differential driver which can be programmed for either two-level (10Base-T, Manchester) or three-level (100Base-TX, MLT-3) transmission. Waveshaping is applied to control the output edge rate and eliminate the need for expensive external filters. The transmitter interfaces directly to an inexpensive isolation transformer (magnetics).

Line Receiver The line receiver circuit accepts either a differential two-level (10Base-T, Manchester) or three-level (100Base-TX, MLT-3) signal which first passes through an isolation transformer. If the polarity correct bit in the Configuration Register is asserted, the ICS1890 has sensed the reversed polarity of the receive pair and can switch polarity automatically.

Magnetics A Universal Magnetics module is used to provide isolation and signal coupling onto the twisted pair cabling for both 10Base-T and 100Base-TX.



10Base-T Block Diagram

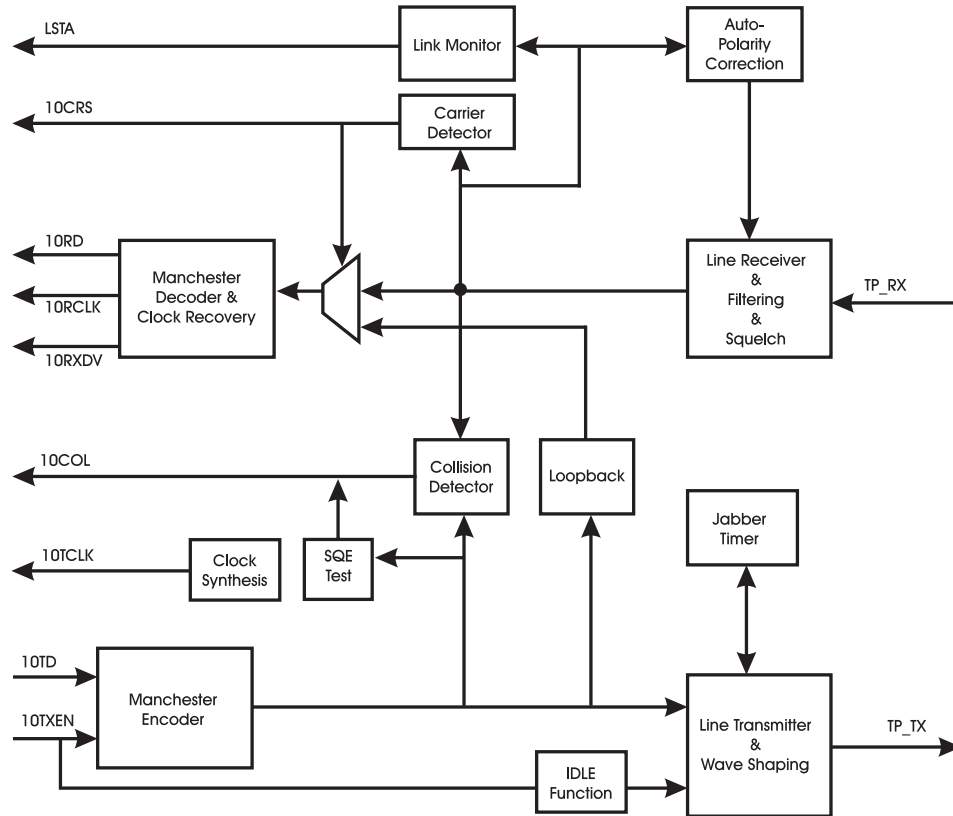

10Base-T

Manchester Encoder/Decoder

When the ICS1890 is operating in the 10Base-T mode, Manchester coding is used. When transmitting, nibbles from the MII are converted to a serial bit stream and then Manchester en-coded. When receiving, the Manchester encoded bit stream is decoded and converted to nibbles for presentation to the MII.

Clock Synthesis

A 2.5 MHz clock is synthesized for nibble wide transactions. A 10 MHz clock is synthesized for serial transactions.

Clock Recovery

The PLL synchronizes on the MAC frame preamble and then begins recovering data normally.

Idle Function

The Idle function is used to keep a 10Base-T link alive in the absence of data transmission.

If no data traffic is transmitted for 16ms, a link pulse will be transmitted. Link pulse transmission will continue every 16ms until real data is transmitted.

Link Monitor

This function is used to qualify a 10Base-T link. If neither data or a Link Pulse is received for 50 to 150ms, then the link is considered down. This state is exited after data is received or 3 to 10 Link Pulses are received.



ICS1890

Carrier Detector

In half duplex mode carrier is asserted during transmission or reception of data. In full duplex or repeater mode, carrier is asserted only on reception of data.

Collision Detector

Collision occurs whenever there is simultaneous transmit and receive activity when a half duplex link is established. Collision never occurs in full duplex mode.

Jabber

The Jabber function prevents the transmitter from erroneously transmitting for too long a period. The maximum time the device should transmit continuously is the time it takes to send a maximum length packet (1500 bytes). The Jabber function ensures that transmission lasts no longer than 20-150ms. The typical value for the **ICS1890** is 21ms.

When the jabber timer is exceeded, Collision (COL) is asserted and the transmit output goes idle for $0.5 \pm 0.25s$.

This function can be disabled with the Jabber Inhibit register bit (18:5).

SQE Test

This test is only used in Half Duplex DTE applications and is disabled in repeater and Full Duplex mode. This test can also be disabled with the SQE Test Inhibit register bit (18:2).

When enabled and a link is established, 0.6 to 1.6us after the last positive transition of a transmitted packet, COL will be asserted for 10 ± 5 bit times.

Manchester Encoder/Decoder

When the **ICS1890** is operating in the 10Base-T mode, Manchester coding is used. When transmitting nibbles from the MII are converted to a serial bit stream and then Manchester encoded. When receiving, the Manchester encoded bit stream is decoded and converted to nibbles for presentation to the MH.

Clock Synthesis

A 2.5MHz clock is synthesized for nibble wide transactions.
A 10MHz clock is synthesized for serial transactions.

Clock Recovery

The PLL synchronizes on the MAC frame preamble and then begins recovering data normally.

Squelch

The squelch function qualifies the data coming into the device so that spurious noise events are rejected.

Auto Polarity Correction

By examining the polarity of received Link Pulses the **ICS1890** can determine if the two wires in the receive data pair were wired correctly. If the wires were accidentally reversed during installation, the Auto Polarity Correction function can automatically correct this in the **ICS1890**. If the **ICS1890** corrects the polarity, this is reflected in the 10Base-T Operations register. This function can also be disabled through the same register, if desired.

Line Transmitter

The line transmitter logic of the **ICS1890** is a current-driven differential driver which can be programmed for either two-level (10Base-T, Manchester) or three-level (100Base-TX, MLT-3) transmission. Wavespaping is applied to control the output edge rate and eliminate the need for expensive external filters. The transmitter interfaces directly to an inexpensive isolation transformer (magnetics).

Line Receiver

The line receiver circuit accepts either a differential two-level (10Base-T, Manchester) or three-level (100Base-TX, MLT-3) signal which first passes through an isolation transformer. If the polarity correct bit in the Configuration Register is asserted, the **ICS1890** will sense the polarity of the receive pair and, if necessary, switch polarity automatically.

Magnetics

A Universal Magnetics module is used to provide isolation and signal coupling onto the twisted pair cabling for both 10Base-T and 100Base-TX.



Management Interface

The **ICS1890** provides a management interface to connect to a management entity. The two wire serial interface is part of the MII and is described in the MII section. The interface allows the transport of status information from the **ICS1890** to the management entity and the transport of control information to the **ICS1890**. It includes a register set, a frame format, and a protocol.

Management Register Set

The register set includes the mandatory basic control and status registers and an extended set. The **ICS1890** implements the following registers.

Control	(register 0)
Status	(register 1)
PHY Identifier	(register 2)
PHY Identifier	(register 3)
Auto-Negotiation Advertisement	(register 4)
Auto-Negotiation Link Partner Ability	(register 5)
Auto-Negotiation Expansion	(register 6)
Reserved by IEEE	(registers 7-15)
Extended Control	(register 16)
QuickPoll Status	(register 17)
10Base-T Operations	(register 18)
Extended Control 2	(register 19)
Reserved by ICS	(registers 20-31)

Management Frame Structure

The management interface uses a serial bit stream with a specified frame structure and protocol as defined below.

Preamble	11...11	(32 ones)
SOF	01	(2 bits)
Op Code	10 (read), 01 (write)	(2 bits)
Address	AAAAA	(5 bits)
Register	RRRRR	(5 bits)
TA	NN	(2 bits)
Data	DD...DD	(16 bits)
Idle	Zo	high impedance

Preamble

The **ICS1890** looks for a pattern of 32 logic ones followed by the SOF delimiter before responding to a transaction.

Start of Frame

Following the preamble a start of frame delimiter of zero-one initiates a transaction.

Operation Code The valid codes are 10 for a read operation and 01 for a write operation. Other codes are ignored.

Address

There may be up to 32 PHYs attached to the MII. This 5 bit address is compared to the internal address of the **ICS1890**, as set by the P[0...4]* pins, for a match.

Register Address

The **ICS1890** uses this field to select one of the registers within the set. If a non-existent register is specified, the **ICS1890** ignores the command.

TA

This 2-bit field is used by the **ICS1890** to avoid contention during read transactions. The **ICS1890** will remain in the high impedance state for the first bit time and drive a logic zero for the second bit time.

Data

This is a 16-bit field with bit 15 being the first bit sent or received.

Idle

The **ICS1890** is in the high impedance state during the idle condition. At least one idle must occur after each write to the device. No idles are required after a read.



ICS1890

Register Access Rules

RO	-	Read Only, writes ignored
CW	-	Command Override Writable
RW/0	-	Read/Write only logic zero
RW	-	Read/Write

Four types of register access are supported by the device. Read Only (RO) bits may be read, but writes are ignored. Command Override Writable (CW) bits may be read, but writes are ignored unless preceded by writing a logic one to the Command Register Override bit (16:15). ReadWrite Zero (RW/0) bits may be read, but must only be written with a logic zero value. Writing a logic one to this type of bit may prevent the device from operating normally. Read Write (RW) bits may be read and may be written to any value.

Default Values

-	-	No default value
0	-	Default to logic zero
1	-	Default to logic one
Pin name	-	Default depends on the state of the named pin

Modifier

SC	-	Self Clearing
LL	-	Latching Low
LH	-	Latching High

Self clearing bits will clear without any further writes after a specified amount of time. Latching bits are used to capture an event. To obtain the current status of a latching bit, the bit must be read twice in succession. If the special condition still persists, the bit will be the same on the second read; otherwise, the condition indication will not be present.



Control Register (register 0 [0x00])

Bit	Definition	When bit=0	When bit=1	Access	Default	Hex
15	Reset	no effect	reset the PHY	RW/SC	0	3
14	Loopback	disable loop back mode	enable loop back mode	RW	0	
13	Data Rate	10 Mb/s operation	100 Mb/s operation	RW	1	
12	Auto-Negotiation Enable	disable Auto-Negotiation	enable Auto-Negotiation	RW	1	
11	Power-Down	normal mode	reduced power consumption	RW	0	0*
10	Isolate	no effect	isolate PHY from MII	RW	0 if PHY Address > 0 1 if PHY Address=0	
9	Restart Auto-Negotiation	no effect	restart Auto-Negotiation	RW	0	
8	Duplex Mode	half duplex	full duplex	RW	0	
7	Collision Test	no effect	enable collision signal test	RW	0	0
6	Reserved	always 0		RO	0	
5	Reserved	always 0		RO	0	
4	Reserved	always 0		RO	0	
3	Reserved	always 0		RO	0	0
2	Reserved	always 0		RO	0	
1	Reserved	always 0		RO	0	
0	Reserved	always 0		RO	0	

Control Register (register 0)

The control register is a 16-bit read/write register used to set the basic configuration modes of the **ICS1890**. It is accessed through the management interface of the MII.

Reset (bit 15)

Setting this bit to a logic 1 will reset the device and result in the **ICS1890** setting all its status and control registers to their default values. During this process the **ICS1890** may change internal states and the states of physical links attached to it. While in process, the bit will remain set and no other write commands to the control register will be accepted. The reset process will be completed within 500 ms and the bit will be cleared indicating that the reset process is complete.

Loop Back (bit 14)

Setting this bit to a logic one causes the **ICS1890** to tristate the transmit circuitry from sending data and the receive circuitry from receiving data. The collision detection circuitry is also disabled unless the collision test command bit is set. Data presented to the MII transmit data path is returned to the MII receive data path. The delay from the assertion of Transmit Data Enable (TXEN) to the assertion of Receive Data valid (RXDV) will be less than 512 bit times.



ICS1890

Data Rate (bit 13)

If Auto-Negotiation is disabled, setting this bit to a logic one causes the **ICS1890** to operate in the 100 Mbps mode only and setting this bit to a logic zero causes it to operate in the 10 Mbps mode only. If Auto-Negotiation is enabled, this bit, if read, has no meaning and, if written, has no effect on the **ICS1890** operation. This bit also has no meaning when Hardware Priority mode is selected with the HW/SW pin. The status of the HW/SW pin is reflected in register bit 19:14. When Hardware Priority mode is selected, the 10/100SEL pin sets the speed. The Data Rate status bit in the QuickPoll register (17:14) always shows the correct setting of an active link.

Auto-Negotiation Enable (bit 12)

Setting this bit to a logic one causes the **ICS1890** to determine the link configuration using the auto-negotiation process. This will be accomplished by the ICS Auto-Negotiation logic and the state of the Data Rate (bit 13) and the Duplex Mode (bit 8) will be ignored. Setting this bit to a logic zero will cause the link configuration to be determined by bits 8 & 13 or the DPXSEL & 10/100SEL pins as selected by the HW/SW pin. This bit has no meaning when Hardware Priority mode is selected with the HW/SW pin. In this case, the ANSEL pin controls Auto-Negotiation use.

Power-Down (bit 11)

Setting this bit to a logic zero has no effect on the **ICS1890**. Setting it to logic one will cause the **ICS1890** to isolate its transmit data output and its MII interface with the exception of the management interface. The **ICS1890** will then enter a Low Power mode where only the management interface and logic remain active. Setting this bit to logic zero after it has been set to a logic one will cause the **ICS1890** to power-up its logic and then reset all error conditions. It then enables transmit data and the MII interface.

Isolate (bit 10)

Setting this bit to a logic one causes the **ICS1890** to isolate its data paths from the MII. In this mode, sourced signals (TXCLK, RXCLK, RXDV, RXER, RXD0-3, COL and CRS) are in a high impedance state and input signals (TXD0-3, TXEN and TXER) are ignored. The management interface is unaffected by this command.

Restart Auto-Negotiation (bit 9)

Setting this bit to a logic one causes the **ICS1890** to restart auto-negotiation. Upon initiation, this bit will be reset to zero. Setting this bit has no effect if auto-negotiation is not enabled.

Duplex Mode (bit 8)

If Auto-Negotiation is disabled, setting this bit to a logic one causes the **ICS1890** to operate in the full duplex mode and setting this bit to a logic zero causes it to operate in the half duplex mode. If Auto-Negotiation is enabled, this bit, if read, has no meaning and, if written, has no effect on the **ICS1890** operation. This bit also has no meaning when Hardware Priority mode is selected with the HW/SW pin. In this case, the DPXSEL pin sets the duplex mode. If the **ICS1890** is operating in loop back mode, this bit will have no effect on the operation.

Collision Test (bit 7)

This command bit is used to test that the collision circuitry is working when the **ICS1890** is operating in the loop back mode. Setting this bit to a logic one causes the **ICS1890** to assert the collision signal within 512 bit times of TXEN being asserted and to de-assert it within 4-bit times of TXEN being de-asserted. Setting this bit to a logic zero causes the **ICS1890** to operate in the normal mode.

Reserved (Bits 6 through 0)

These bits are reserved for future IEEE standards. When read, logic zeros are returned. Writing has no effect on **ICS1890** operation.



Status Register (register 1 [0x01])

Bit	Definition	When bit=0	When bit=1	Access	Default	Hex
15	100Base-T4	always 0		RO	0	7
14	100Base-TX Full Duplex	TX full duplex not supported	TX full duplex supported	CW	1	
13	100Base-TX Half Duplex	TX half duplex not supported	TX half duplex supported	CW	1	
12	10Base-T Full Duplex	10 full duplex not supported	10 full duplex supported	CW	1	
11	10Base-T Half Duplex	10 half duplex not supported	10 half duplex supported	CW	1	8
10	Reserved by IEEE			CW	0	
9	Reserved by IEEE			CW	0	
8	Reserved by IEEE			CW	0	
7	Reserved by IEEE			CW	0	0
6	MF Preamble Suppression	Frames must have preamble		RO	0	
5	Auto-Negotiation Complete	Auto-Negotiation in process	Auto-Negotiation completed	RO	0	
4	Remote Fault	no fault detected	partner indicated a fault	RO /LH	0	
3	Auto-Negotiation Ability	PHY is not able to Auto-Negotiate	PHY is able to Auto-Negotiate	RO	1	9
2	Link Status	link is not valid	link is valid	RO /LL	0	
1	Jabber Detect	no jabber detected	jabber detected	RO /LH	0	
0	Extended Capability	always 1		RO	1	

Status (register 1)

The **ICS1890** status register is a 16-bit read-only register used to indicate the basic status of the **ICS1890**. It is accessed via the management interface of the MII. It is initialized during a power-up or reset to pre-defined default values.

100Base-T4 (bit 15)

This bit is permanently set to a logic zero indicating that the **ICS1890** is not able to support 100Base-T4 operation.

100Base-X Full Duplex (bit 14)

This bit defaults to a logic one indicating that the **ICS1890** is able to support 100Base-X Full Duplex operation.

100Base-X Half Duplex (bit 13)

This bit defaults to a logic one indicating that the **ICS1890** is able to support 100Base-X Half Duplex operation.

10 Mbps Full Duplex (bit 12)

This bit defaults to a logic one indicating that the **ICS1890** is able to support 10Base-T Full Duplex operation.

10 Mbps Half Duplex (bit 11) This bit defaults to a logic one indicating that the **ICS1890** is able to support 10Base-T Half Duplex operation.

Reserved (Bits 10 through 7)

These bits are reserved for future IEEE standards. When read, logic zeroes are returned. Writing has no effect on **ICS1890** operation. These bits may, however, be set using the Command Override mechanism. This should only be done in accordance with the IEEE 802.3 standard.

MF Preamble Suppression (bit 6)

This bit is permanently set to a logic zero indicating that the **ICS1890** is not able to support management frames not preceded by a normal size preamble.



ICS1890

Auto-Negotiation Complete (bit 5)

When set to a logic one, this bit indicates that the **ICS1890** has completed the auto-negotiation process and that the contents of registers 4, 5 and 6 are valid. When set to a logic zero, this bit indicates that auto-negotiation is not complete

Remote Fault (bit 4)

When set to a logic one, this bit indicates that a remote fault has been detected by Auto-Negotiation. This bit remains set to a logic one until the fault condition goes away and the register bit is cleared by reading the status register or by a reset command.

Auto-Negotiation Ability (bit 3) This bit defaults to a logic one indicating that the **ICS1890** is able to support Auto-Negotiation.

Link Status (bit 2)

When set to a logic one, this bit indicates that the Link Monitor has established a valid link. If the Link Monitor detects a link failure, this bit is set to a logic zero and remains zero through the next read of the status register. A link failure may be due to an error in the receive channel or an error in the receive channel of the link partner (that is, a “remote fault”).

If auto-negotiation mode is enabled, a local receive channel error will occur if link pulses are not present during the auto-negotiation process or when operating in the 10Base-T mode.

Jabber detect (bit 1)

When set to logic one, this bit indicates that the **ICS1890** has detected the jabber condition. It remains set until cleared by reading the status register.

Extended Capability (bit 0)

This bit is permanently set to a logic one indicating that the **ICS1890** has an extended register set.



PHY Identifier Register (register 2 [0x02])

Bit	Definition	When bit=0	When bit=1	Access	Default	Hex
15	OUI bit 3 c			CW	0	0
14	OUI bit 4 d			CW	0	
13	OUI bit 5 e			CW	0	
12	OUI bit 6 f			CW	0	
11	OUI bit 7 g			CW	0	0
10	OUI bit 8 h			CW	0	
9	OUI bit 9 I			CW	0	
8	OUI bit 10 j			CW	0	
7	OUI bit 11 k			CW	0	1
6	OUI bit 12 l			CW	0	
5	OUI bit 13 m			CW	0	
4	OUI bit 14 n			CW	1	
3	OUI bit 15 o			CW	0	5
2	OUI bit 16 p			CW	1	
1	OUI bit 17 q			CW	0	
0	OUI bit 18 r			CW	1	

PHY Identifier Register (register 2)

Register 2 and Register 3 contain the 24-bit Organizationally Unique Identifier (OUI), Manufacturers Model Number and Revision Number. Integrated Circuit Systems’ OUI is used as the default for registers 2 and 3.

These two registers can always be read and may be written by setting the Command Override bit in the Configuration register (16:15) and then performing a write operation. At power-up and reset they are set to Integrated Circuit Systems’ OUI. By allowing these registers to be written, a systems vendor may substitute their own OUI.

Organizationally Unique Identifier bits 3-18 (bits 15-0)

This field contains the lowest 16 bits of the IEEE OUI excluding OUI maps to bit 15 of the register.

OUI Formatting Information The ICS OUI is shown below with information on mapping the OUI value into registers 2 and 3.

Octet Format:

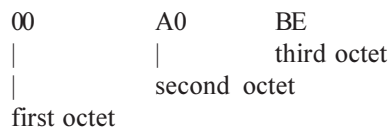

Binary Format:

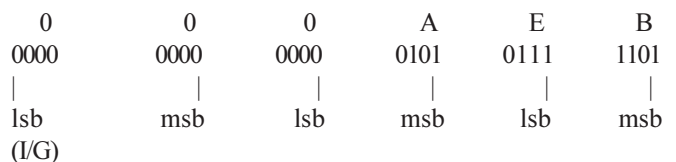

IEEE Standard 802 Lettered Format

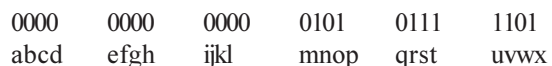



ICS1890

PHY Identifier Register (register 3 [0x03])

Bit	Definition	When bit=0	When bit=1	Access	Default	Hex
15	OUI bit 19 s			CW	1	F
14	OUI bit 20 t			CW	1	
13	OUI bit 21 u			CW	1	
12	OUI bit 22 v			CW	1	
11	OUI bit 23 w			CW	0	4
10	OUI bit 24 x			CW	1	
9	Manufacturer's Model Number bit 5			CW	0	
8	Manufacturer's Model Number bit 4			CW	0	
7	Manufacturer's Model Number bit 3			CW	0	2
6	Manufacturer's Model Number bit 2			CW	0	
5	Manufacturer's Model Number bit 1			CW	1	
4	Manufacturer's Model Number bit 0			CW	0	
3	Revision Number bit 3			CW	0	3
2	Revision Number bit 2			CW	0	
1	Revision Number bit 1			CW	1	
0	Revision Number bit 0			CW	1	

PHY Identifier Register (register 3)

Register 2 and Register 3 contain the 24 bit Organizationally Unique Identifier (OUI), Manufacturers Model Number and Revision Number. Integrated Circuit Systems' OUI is used as the default for registers 2 and 3.

These two registers can always be read and may be written by setting the Command Override bit in the Configuration register (16:15) and then performing a write operation. At power-up and reset they are set to Integrated Circuit Systems' OUI. By allowing these registers to be written, a systems vendor may substitute their own OUI.

See register 2 for OUI formatting information.

Organizationally Unique Identifier bits 19-24 (bits 15-10)

This field contains the upper 6 bits of the IEEE OUI. Bit 19 of the OUI maps to bit 15 of the register.

Manufacturer's Model Number bits 5-0 (bits 9-4)

Model	Part
1	ICS1889
2	ICS1890

Revision Number bits 3-0 (bits 3-0)

The revision number will be incremented each time the silicon is significantly revised. Currently the device is at revision 2.

Revision	Description
0	ICS Internal Release
1	1st Alpha Customer Samples
2	1st General Release
3	1890 "J" Release and above



Auto-Negotiation Advertisement Register (register 4 [0x04])

Bit	Definition	When bit=0	When bit=1	Access	Default	Hex
15	Next Page	always 0 - not capable of sending next pages		RO	0	0
14	Reserved by IEEE	always 0		RO	0	
13	Fault Indication to link partner	no fault	a fault has occurred locally	RW	0	
12	Technology Ability Field bit A7	reserved by IEEE		CW	0	
11	Technology Ability Field bit A6	reserved by IEEE		CW	0	1
10	Technology Ability Field bit A5	reserved by IEEE		CW	0	
9	TAF bit A4: 100Base-T4 Capability	always 0 - 100Base-T4 not supported		RO	0	
8	TAF A3: 100Base-TX Full Duplex Capability	100Base-TX FD not desired	100Base-TX FD supported	RW	1	E
7	TAF A2: 100Base-TX Half Duplex Capability	100Base-TX HD not desired	100Base-TX HD supported	RW	1	
6	TAF A1: 10Base-T Full Duplex Capability	10Base-T FD not desired	10Base-T FD supported	RW	1	
5	TAF A0: 10Base-T Half Duplex Capability	10Base-T HD not supported	10Base-T HD supported	RW	1	
4	Selector Field bit S4	IEEE 802.3 default		CW	0	1
3	Selector Field bit S3	IEEE 802.3 default		CW	0	
2	Selector Field bit S2	IEEE 802.3 default		CW	0	
1	Selector Field bit S1	IEEE 802.3 default		CW	0	
0	Selector Field bit S0	IEEE 802.3 default		CW	1	

Auto-Negotiation Advertisement Register (register 4)

The Auto-Negotiation advertisement register is a 16-bit read/write register used to indicate the basic capabilities of the local device. The values written into this register are exchanged with the remote link partner to determine the best link technology to enable. Normally it is desirable to advertise all of the capabilities supported by a node. In some cases a certain technology is not desired and in this case the corresponding bit can be set to logic zero. If a connection cannot be made in this case, management should enable all of the capabilities possessed and restart Auto-Negotiation.

Next Page (bit 15)

The ICS1890 does not support the next page function. This bit is permanently set to a logic zero.

Reserved by IEEE (bit 14)

This reserved bit has no effect on the ICS1890. When read, a logic zero is always returned.



ICS1890

Remote Fault (bit 13) Management may set this bit to a logic one, which sets the remote fault bit in the transmitted base link code word to a logic one. This indicates to the link partner that an error has been detected at this end.

The Auto-Negotiation Power-up Remote Fault option (19:4) can also cause the remote fault bit in the transmitted base link code word to be set to a logic one.

Technology Ability Field (bits 12:5) This 8-bit field specifies the data transmission technologies supported by the **ICS1890**. On power-up when the HW/SW pin is set to SW, these bits are set to the values specified in the MII Status register. When the HW/SW pin is set to HW and ANSEL is enabled, the single bit corresponding to the values of the DPXSEL and 10/100SEL pins is enabled. All bits, except the 100Base-T4 (unsupported technology bit) may be set or cleared allowing management to select the advertised technologies. Note that bits 12-10 are currently reserved by the IEEE Auto-Negotiation standard and should always be set to logic zero.

Selector Field (bits 4:0) This 5-bit field is used to select the technology supported by the **ICS1890**. It defaults to select IEEE 802.3 (00001). These bits can only be written using the command override mode and should only be set to a different value as allowed by the IEEE standard



Auto-Negotiation Link Partner Ability Register (register 5 [0x05])

Bit	Definition	When bit=0	When bit=1	Access	Default	Hex
15	Next Page	partner does not support next page exchange	partner supports next page exchange	RO	0	0
14	Reserved by IEEE	always 0		RO	0	
13	Remote Fault	no fault	a fault has occurred at the remote link partner	RO	0	
12	Technology Ability Field bit A7	reserved by IEEE		RO	0	
11	Technology Ability Field bit A6	reserved by IEEE		RO	0	0
10	Technology Ability Field bit A5	reserved by IEEE		RO	0	
9	TAF bit A4: 100Base-T4 Capability	partner does not support 100Base-T4	partner supports 100Base-T4	RO	0	
8	TAF A3: 100Base-TX Full Duplex Capability	partner does not support 100Base- TX Full Duplex	partner supports 100Base- TX Full Duplex	RO	0	
7	TAF A2: 100Base-TX Half Duplex Capability	partner does not support 100Base- TX Half Duplex	partner supports 100Base- TX Half Duplex	RO	0	0
6	TAF A1: 10Base-T Full Duplex Capability	partner does not support 10Base-T Full Duplex	partner supports 10Base-T Full Duplex	RO	0	
5	TAF A0: 10Base-T Half Duplex Capability	partner does not support 10Base-T Half Duplex	partner supports 10Base-T Half Duplex	RO	0	
4	Selector Field bit S4	see decode table		RO	0	0
3	Selector Field bit S3	see decode table	802.3 = 00001	RO	0	
2	Selector Field bit S2	see decode table	802.9 = 00010	RO	0	
1	Selector Field bit S1	see decode table		RO	0	
0	Selector Field bit S0	see decode table		RO	0	

Auto-Negotiation Link Partner Ability Register (register 5)

The Auto-Negotiation link partner ability register is a 16-bit read-only register used to indicate the abilities of the link partner. When compared to local abilities in register 4 and sorted by the standard IEEE priority table the highest possible performance link can be determined. Note that the values in this register are only valid when Auto-Negotiation is complete as indicated by (1:5) or the equivalent bit in the QuickPoll register.

Next Page (bit 15)

If set to a logic one, this bit indicates that the link partner can operate in the next page mode. Since the ICS1890 does not support the next page function, no action or response results from this indication.

Reserved (bit 14)

This reserved bit will always be returned as a logic zero.

Remote Fault (bit 13)

When the remote fault bit of the Link Code Word is set to a logic one, the ICS1890 sets the remote fault bit in the Link Partner Ability Register to a logic one. This indicates that the link partner has detected an error.

Technology Field (bits 12:5)

This 8-bit field specifies the data transmission technologies supported by the remote partner. The contents are valid on successful completion of Auto-Negotiation as indicated by a logic one in bit 5 of the ICS1890 status register.

Selector Field (bits 4:0)

This 5-bit field indicates the technology supported by the link partner. A valid IEEE 802.3 link partner will always signal (00001). A code of (00010) indicates an IEEE 802.9a partner. All other codes are currently undefined.



ICS1890

Auto-Negotiation Expansion Register (register 6 [0x06])

Bit	Definition	When bit=0	When bit=1	Access	Default	Hex
15	Reserved by IEEE	always 0		CW	0	0
14	Reserved by IEEE	always 0		CW	0	
13	Reserved by IEEE	always 0		CW	0	
12	Reserved by IEEE	always 0		CW	0	
11	Reserved by IEEE	always 0		CW	0	0
10	Reserved by IEEE	always 0		CW	0	
9	Reserved by IEEE	always 0		CW	0	
8	Reserved by IEEE	always 0		CW	0	
7	Reserved by IEEE	always 0		CW	0	0
6	Reserved by IEEE	always 0		CW	0	
5	Reserved by IEEE	always 0		CW	0	
4	Parallel Detection Fault	no fault	more than one technology appeared valid	RO /LH	0	
3	Link Partner Next Page Able	link partner is not Next Page Able	link partner is Next Page Able	RO	0	0
2	Next Page Able	always 0 - next page not supported		RO	0	
1	Page Received	new link code word not received	new link code word received	RO /LH	0	
0	Link Partner is Auto-Negotiation Able	link partner not able	link partner support Auto-Negotiation	RO	0	

Auto-Negotiation Expansion Register (register 6)

The Auto-Negotiation expansion register is a 16-bit read-only register used to indicate the status of the auto-negotiation process. It is accessed via the management interface of the MII.

Reserved (bits 15:5)

These bits are reserved. The contents are permanently set to logic zeros.

Parallel Detection Fault (bit 4)

If set to a logic one, this bit indicates that a parallel detection fault has been detected. This means that more than one of the allowed technologies has detected a valid link.

Link Partner Next Page Able (bit 3)

If set to a logic one, this bit indicates that the link partner is capable of operating in the next page mode.

Next Page Able (bit 2)

This bit is permanently set to a logic zero indicating that the ICS1890 is not able to operate in the next page mode.

Page Received (bit 1)

If set to a logic one, this bit indicates that three identical and consecutive link code words have been received from the link partner.

Link Partner Auto-Negotiation Able (bit 0)

If set to a logic one, this bit indicates that the link partner is able to participate in the auto-negotiation process. If set to a logic zero, it is not able to participate in the auto-negotiation process.



Extended Control Register (register 16 [0x10])

Bit	Definition	When bit=0	When bit=1	Access	Default	Hex
15	Command Register Override	don't allow writes to CW bits	allow next write to effect both RW & CW bits	RW /SC	0	
14	Reserved for ICS	Read unspecified		RW /0	-	
13	Reserved for ICS	Read unspecified		RW /0	-	
12	Reserved for ICS	Read unspecified		RW /0	-	
11	Reserved for ICS	Read unspecified		RW /0	-	
10	PHY address bit 4	A		RO	P4RD	
9	PHY address bit 3	MII Management's		RO	P3TD	
8	PHY address bit 2	Register Address code		RO	P2LI	
7	PHY address bit 1	0 - 31 Read Only		RO	P1CL	
6	PHY address bit 0	Read unspecified		RO	P0AC	
5	Stream Cipher Scrambler Test Mode	normal	test mode	RW	0	
4	Reserved for ICS	Read unspecified		RW /0	-	
3	NRZ/NRZ1 Encoding	NRZ	NRZ1	RW	1	
2	Invalid Error Code Test	disabled	enabled	RW	0	
1	Reserved for ICS	Read unspecified		RW /0	-	
0	Stream Cipher Disable	enabled	disabled	RW	0	

Extended Control Register (register 16)

The Control Register is a 16-bit read/write register used to pre-program the ICS1890. At power-up and reset, this register will be loaded to the default values specified in the table above.

Command Register Override (bit 15)

If set to a logic one, this bit allows a subsequent write to any Command Writeable bit (CW) in any register. A write to any register after this bit is set will reset the bit, preventing subsequent writes to Command Writeable bits from having any effect. Therefore, each write to a Command Writeable bit must be preceded by writing a logic one to this bit.

Bits Reserved for ICS use (14-11)

These bits are reserved for ICS use. These bits should only be written as logic zero. Writing a logic one to these bits may prevent the device from operating correctly. The value of these bits is unspecified and may be a logic zero or one.

PHY Address (Bits 10 through 6)

These five bits are used to indicate the address of the ICS1890 on the management port of the MII (any number in the range 0 - 31). The connection of the LEDs to the LED pins sets the address. A read returns the address. A write is ignored.

Stream Cipher Scrambler Test Mode (Bit 5)

If set to a logic one, the scrambler will resynchronize after 252 bits of non-idle data instead of its normal time.

Bits Reserved for ICS use (Bit 4)

These bits are reserved for ICS use. These bits should only be written as logic zero. Writing a logic one to these bits may prevent the device from operating correctly. The value of these bits is unspecified and may be a logic zero or one.

NRZ/NRZ1 Encoding (bit 3)

When this bit is 1 normal NRZ1 encoding of data is performed for 100Base-TX. When this bit is 0 NRZ coding is used instead. NRZ encoding can be useful for system debug.

Invalid Error Code Test (bit 2)

If this bit is set to a logic one, the 4B5B encoder allows non-data symbols to be sent when TXER is asserted. See the Invalid Error Code Test table for the symbol mapping.

Reserved for ICS use (bit 1)

These bits are reserved for ICS use. These bits should only be written as logic zero. Writing a logic one to these bits may prevent the device from operating correctly. The value of these bits in unspecified and may be a logic zero or one.

Stream Cipher Disable (bit 0)

If this bit is set to a logic one, the stream cipher encoder and decoder are disabled. This will result in unscrambled IDLES and data streams being transmitted and received for ease of debug



ICS1890

QuickPoll Detailed Status Register (register 17 [0x11])

Bit	Definition	When bit=0	When bit=1	Access	Default	Hex
15	Data Rate	10 Mb/s negotiated	100 Mb/s negotiated	RO	*	
14	Duplex	half duplex negotiated	full duplex negotiated	RO	*	
13	Auto-Negotiation Progress Monitor bit 2	see decode table		RO /LL /LH	0	
12	Auto-Negotiation Progress Monitor bit 1	see decode table		RO /LL /LH	0	
11	Auto-Negotiation Progress Monitor bit 0	see decode table		RO /LL /LH	0	
10	Receive Signal Error	signal	loss of signal	RO /LH	0	
9	PLL Lock Error	PLL locked	PLL failed to lock	RO /LH	0	
8	False Carrier Detect	normal carrier or idle	false carrier detected	RO /LH	0	
7	Invalid Symbol	valid symbols	invalid symbol detected	RO /LH	0	
6	Halt Symbol	normal symbols	HALT symbol detected	RO /LH	0	
5	Premature End	normal stream	stream with two IDLE symbols	RO /LH	0	
4	Auto-Negotiation complete	Auto-Negotiation progress	Auto-Negotiation complete	RO	0	
3	Signal Detect 100Base-TX	SD active	SD inactive	RO	-	
2	Jabber Detect	no jabber detected	jabber detected	RO /LH	0	
1	Remote Fault	no remote fault detected	remote fault detected	RO /LH	0	
0	Link Status	link is not valid	link is valid	RO /LL	0	

QuickPoll Detailed Status (register 17)

The ICS1890 detailed status register is a 16-bit read-only register used to indicate detailed status of the ICS1890. It is accessed via the management interface of the MII. It is initialized during a power-up or reset to pre-defined default values. A number of bits are duplicated in this register from others to make them more easily accessible when polling the device for status. This should be the only register that needs to be repeatedly polled in an application.

Data Rate (bit 15)

If set to a logic one, this bit indicates that has been selected 100 Mbps mode. If set to a logic zero, it indicates that the initial-10 Mbps mode has been selected. This bit's setting depends on the setting of the HW/SW pin, 10/100SEL pin, ANSEL pin, and the setting of bits 0:12, 0:13, and 1:5.



Duplex (bit 14)

If set to a logic one, this bit indicates that full duplex mode has been selected. If set to a logic zero, it indicates that half duplex mode has been selected. This bit's setting depends on the setting of the HW/SW pin, DPXSEL pin, ANSEL pin, and the setting of bits 0:12, 0:8, and 1:5.

Auto-Negotiation Progress (bit 13 - 11)

These three bits are encoded to indicate the progress of the auto-negotiation cycle. These bits are initialized to zero. The values indicate the progress of auto-negotiation. See the Auto-Negotiation Progress Monitor section for the encodings and additional details.

Receive Signal Error (bit 10)

If set to a logic one, the receive channel signal (bit 15) indicates that the ICS1890 read channel has, at some point, been unable to detect the receive channel signal (either the IDLE stream in 100Base-TX mode or link pulses in 10Base-T mode). This bit will remain set until cleared by reading the contents of register 17.

PLL Lock Error (bit 9)

If set to a logic one, the loss of PLL lock indicates that the ICS1890 read channel PLL has failed to lock onto the read channel signal. This bit will remain set until cleared by reading the contents of register 17.

False Carrier (bit 8)

If set to a logic one, the false carrier indicates that the ICS1890 has detected a false carrier sometime since this bit was last reset. This bit will remain set until cleared by reading the contents of register 17.

Invalid Symbol (bit 7)

If set to a logic one, the invalid symbol indicates that an invalid symbol has been detected in a received frame since the bit was last reset. This bit will remain set until cleared by reading the contents of register 17.

Halt Symbol (bit 6)

If set to a logic one, the halt symbol (bit 10) indicates that the ICS1890 has detected the halt symbol in a frame since bit 11 was last reset. This bit will remain set until cleared by reading the contents of register 17.

Premature End (bit 5)

This bit is normally a logic zero indicating normal data streams. If two IDLE symbols are detected during the reception of a receive data stream, this bit is set to a logic one and the ICS1890 returns to the idle state. This bit is initialized to a logic zero.

Auto-Negotiation Complete (bit 5)

When set to a logic one, this bit indicates that the ICS1890 has completed the auto-negotiation process and that the contents of registers 4, 5 and 6 are valid. When set to a logic zero, this bit indicates that auto-negotiation is not complete or that auto-negotiation has been disabled in the command register (bit 12).

100Base_TX Signal Detect (bit 3)

The absence of 100Base_TX signaling on the TP_RX± pins will cause this bit to be asserted (1)

Jabber Detect (bit 2)

When operating in the 10Base-T mode, if set to a logic one, this bit indicates that a jabber condition occurred and that the transmit pair has been isolated.

Remote Fault (bit 1) This is a copy of the Remote Fault bit of the Status Register (register 1).

Link Status (bit 0) This is a copy of the Link Status bit of the Status Register (register 1).



ICS1890

10Base-T Operations Register (register 18 [0x12])

Bit	Definition	When bit=0	When bit=1	Access	Default	Hex
15	Reserved for ICS	Read unspecified	must be wirtten as a 0	RW /0	0	
14	Polarity Reversed	polarity normal	polarity reserved	RO /LH	0	
13	Reserved for ICS	Read unspecified		RW /0	-	
12	Reserved for ICS	Read unspecified		RW /0	-	
11	Reserved for ICS	Read unspecified		RW /0	-	
10	Reserved for ICS	Read unspecified		RW /0	-	
9	Reserved for ICS	Read unspecified		RW /0	-	
8	Reserved for ICS	Read unspecified		RW /0	-	
7	Reserved for ICS	Read unspecified		RW /0	-	
6	Reserved for ICS	Read unspecified		RW /0	-	
5	Jabber Inhibit	normal jabber behavior	no jabber check	RW	0	
4	Reserved for ICS	Read unspecified	must be written as a 1	RW /1	1	
3	Auto Polarity Inhibit	polarity automatically corrected	polarity not corrected	RW	0	0
2	SQE Test Inhibit	normal SQE test behavior	no SQE test	RW	0	
1	Link Loss Inhibit	normal Link Loss behavior	link always = Link Pass	RW	0	
0	Squelch Inhibit	normal Squelch	no Squelch	RW	0	

10Base-T Operations Register (register 18)

This register contains all of the extra status and control bits required for 10Base-T operation.

Bits Reserved for ICS use (15, 13, 6)

These bits are reserved for ICS use. These bits should only be written as logic zero. Writing a logic one to these bits may prevent the device from operating correctly. The value of these bits is unspecified and may be a logic zero or one.

Polarity Reversed (bit 14)

This bit is set to a logic one if the polarity of the receive data pair is reversed. This bit will be a logic zero if the polarity is correct.

Jabber Inhibit (bit 5)

Setting this bit to a logic one turns off the internal check for transmit jabber. When the jabber check is disabled, no action occurs when transmissions are longer than the jabber timer value. When this bit is set to a logic zero normal 10Base-T jabber checking is enabled.

Bit Reserved for ICS use (bit 4)

This bit must be written to a 1. The read value of this bit is undefined.

Auto Polarity Inhibit (bit 3)

When this bit is set to a logic one, correction for reversed receive data wires is disabled. When this bit is set to a logic Zero, reversed receive data wires are automatically corrected for internally.



SQE Test Inhibit (bit 2)

When this bit is set to a logic one, SQE testing is disabled. When this bit is set to a logic zero, a normal 10Base-T SQE test is performed by pulsing the Collision signal for a short time shortly after each packet transmission completes.

Note that the SQE Test is automatically inhibited in Full Duplex and Repeater modes.

Link Loss Inhibit (bit 1)

When this bit is set to a logic one, the 10Base-T Link Integrity Test state machine is forced into the Link Pass state regardless of the line conditions. This can be useful in debugging a bad link segment. When this bit is set to a logic zero, the state machine behaves normally.

Squelch Inhibit (bit 0)

When this bit is set to a logic one, the receive squelch circuitry is disabled. This can be useful in debugging a bad link segment or for link segments longer than 100 meters. When this bit is set to a logic zero, the normal Squelch circuitry is enabled to filter out spurious line noise.



ICS1890

Extended Control Register 2 (register 19 [0X13])

Bit	Definition	When bit=0	When bit=1	Access	Default	Hex
15	Node/Repeater Mode	Node Mode	Repeater Mode	RO	NOD/- REP	
14	Hardware/Software Priority	Hardware Priority	Software Priority	RO	HW/S- W	
13	Link Partner Supports Remote Fault	unknown	partner supports Remote Fault	RO	0	
12	Reserved for ICS	Read unspecified		RW /0	-	
11	Reserved for ICS	Read unspecified		RW /0	-	
10	Transmitted Remote Fault Status	RF bit in transmitted LCW=0	RF bit in transmitted LCW=1	RW /0	-	
9	Reserved for ICS	Read unspecified		RW /0	-	
8	Reserved for ICS	Read unspecified		RW /0	-	
7	Reserved for ICS	Read unspecified		RW /0	-	
6	Reserved for ICS	Read unspecified		RW /0	-	
5	Reserved for ICS	Read unspecified		RW /0	-	
4	A-N Power-up Remote Fault	Normal	Remote Fault on Power-up	RW	0	
3	Reserved for ICS	Read unspecified		RW /0	0	
2	Reserved for ICS	Read unspecified		RW /0	-	
1	Reserved for ICS	Read unspecified		RW /0	0	
0	Automatic 100Base-TX Power-down	Never Power-down automatically	Power-down automatically	RW	1	

Extended Control Register 2 (register 19)

Node/Repeater Configuration (bit 15)

This bit directly reflects the status of the NOD/REP pin.

When this bit is logic zero, the device will default to Node operation. SQE test will default to on. Carrier sense in half duplex mode will be on transmit or receive activity.

When this bit is logic one, the device will default to Repeater operation. SQE test will default to off. Carrier sense in half duplex mode will be on receive activity only.

Hardware/Software Priority Status (bit 14)

This bit directly reflects the status of the HW/SW pin.

When this bit is logic zero, hardware pins have priority over software settings. The 10/100SEL pin becomes an input and controls speed selection. The DPXSEL pin becomes an input and controls duplex selection. The ANSEL pin becomes an input and chooses configuration with or without Auto-Negotiation.

When configuration through Auto-Negotiation is selected, the DPXSEL and 10/100SEL settings control the Auto-Negotiation register 4 default settings and Auto-Negotiation is enabled. When configuration without Auto-Negotiation is selected, DPXSEL controls the duplex setting and 10/100SEL controls the data rate setting.

When this bit is a logic one, software bits have priority over hardware pin settings. The 10/100SEL pin becomes an output indicating the link speed when LSTA the link is established and parallels bit (17:15). The DPXSEL pin becomes an output indicating the link duplex state when the link is established and parallels bit (17:14). The ANSEL pin becomes an output indicating whether auto-negotiation is being used and parallels bit(0:12).



Link Partner Remote Fault Capable (bit 13)

This bit tries to indicate if the link partner supports indication of a remote fault. If the **ICS1890** observes the link partner Auto-Negotiating with the Remote Fault bit set, this status bit will be set to a logic one. Otherwise, this bit will be a logic zero.

Note that a logic zero can not definitively mean that the link partner does not support remote fault indications.

Reserved (bits 12-11)

These bits are reserved for ICS use. They must only be written as logic zero. Writing a logic one to any of these bits may prevent the device from operating normally. The value of these bits when read is unspecified and may be a logic zero or one.

Transmitted Remote Fault Status (bit 10)

This bit reflects the current status of the Remote Fault bit in the Transmitted Link Code Word. This bit is set when bit 4:15 is set or when bit 19:4 is set and the link partner is not transmitting.

Reserved (bits 9-5)

These bits are reserved for ICS use. They must only be written as logic zero. Writing a logic one to any of these bits may prevent the device from operating normally. The value of these bits when read is unspecified and may be a logic zero or one.

Power-up Remote Fault (bit 4)

When this bit is set to a logic one, the RF bit in the outgoing Auto-Negotiation Link Code Word will automatically be set to a logic one until receive activity is detected (Normal Link Pulses, Fast Link Pulses, 100Base-TX data, ...).

Bits Reserved for ICS use (bits 3-1)

These bits are reserved for ICS use. These bits should only be written as logic zero. Writing a logic one to these bits may prevent the device from operating correctly. The value of these bits is unspecified and may be a logic zero or one.

Automatic 100Base-TX Power-down (bit 0)

When this bit is set to a logic one and 10Base-T is selected for the network connection, the 100Base-TX transceiver will automatically turn off to save power.

When this bit is set to a logic zero, the 100Base-TX transceiver will never power-down by itself. The 100Base-TX transceiver will still power-down when the entire device is isolated using bit (0:10).



ICS1890

Pin Descriptions

Signal	Meaning	Signal	Meaning
TXCLK*	Transmit Clock	NOD/REP	Node/Repeater Mode
TXEN*	Transmit Enable	MII/SI	MII Data/Stream Interface
TXD3*	Transmit Data 3	10/LP	10M Serial/Link Pulse Interface
TXD2*	Transmit Data 2	HW/SW	Hardware/Software Priority
TXD1*	Transmit Data 1	10/100SEL	10/100 Select
TXD0*	Transmit Data 0	DPXSEL	Duplex Select
TXER*	Transmit Error	ANSEL	Auto-Negotiation Select
		ITCLS~	Invert Transmit Clock Latching Setting
RXCLK*	Receive Clock	TPTRI	Twisted Pair Tristate
RXDV*	Receive Data Valid	RXTRI	Receive MAC-PHY Interface Tristate
RXD3	Receive Data 3	LSTA*	Link Status
RXD2*	Receive Data 2	LOCK	Cipher Lock
RXD1*	Receive Data 1	RESET~	System Reset
RXD0*	Receive Data 0		
RXER*	Receive Error		
CRS*	Carrier Sense		
COL*	Collision Detect		
		P4RD	PHY ID 4/Receive data LED
MDC	Management Data Clock	PSTD	PHY ID 3/Transmit data LED
MDIO	Management Data Input/Output	P2LI	PHY ID 2/Link Integrity LED
		P1CL	PHY ID 1/Collision det LED
REF_IN	Frequency reference	P0AC	PHY ID 0/Activity LED
REF_OUT	Frequency reference		
TP_TX+	Twisted Pair Transmit Data+		
TP_TX-	Twisted Pair Transmit Data-	NC	5 No Connect Pins
TP_RX+	Twisted Pair Receive Data+		
TP_RX-	Twisted Pair Receive Data-		
10TCSR	10M transmit Current Set Resistor	VDD	8 VDD Pins
100TCSR	100M Transmit Current Set Resistor	VSS	7 VSS Pins

*Re-defined for other MAC-PYY interfaces



Pin Descriptions

MII Data Interface

The following pin descriptions apply in either 10 or 100 Mbps mode when the MII Data Interface is selected. These pins are re-used for the 100M Stream Interface, 10M Serial Interface, and the Link Pulse Interface. These extra pin meanings are described in separate interface sections with the “pseudo” pin name followed by the actual pin name that the function is mapped onto.

Transmit Clock TXCLK

The Transmit Clock (TXCLK) is a continuous clock signal generated by the **ICS1890** to synchronize information transfer on the Transmit Enable, Transmit Data and Transmit Error lines. The **ICS1890** clock frequency is 25% of the nominal transmit data rate. At 10 Mbps, its frequency is 2.5 MHz and at 100 Mbps is 25 MHz.

Transmit Enable TXEN

Transmit Enable (TXEN) indicates to the **ICS1890** that the MAC is sending valid data nibbles for transmission on the physical media. Synchronous with its assertion, the **ICS1890** will begin reading the data nibbles on the transmit data lines. It is the responsibility of the MAC to order the nibbles so that the preamble is sent first, followed by destination, source, length, data and CRC fields since the **ICS1890** has no knowledge of the frame structure and is merely a “nibble” processor. The **ICS1890** terminates transmission of nibbles following the de-assertion of Transmit Enable (TXEN).

Transmit Data 3 TXD3

Transmit Data 3 (TXD3) is the most significant bit of the transmit data nibble. TXD3 is sampled by the **ICS1890** synchronously with the Transmit Clock when TXEN is asserted. When TXEN is de-asserted, the **ICS1890** is unaffected by the state of TXD3.

Transmit Data 2 TXD2

Transmit Data 2 (TXD2) is sampled by the **ICS1890** synchronously with the Transmit Clock when TXEN is asserted. When TXEN is de-asserted, the **ICS1890** is unaffected by the state of TXD2.

Transmit Data 1 TXD1

Transmit Data 1 (TXD1) is sampled by the **ICS1890** synchronously with the Transmit Clock when TXEN is asserted. When TXEN is de-asserted, the **ICS1890** is unaffected by the state of TXD1.

Transmit Data 0 TXD0

Transmit Data 0 (TXD0) is the least significant bit of the transmit data nibble. TXD0 is sampled by the **ICS1890** synchronously with the Transmit Clock when TXEN is asserted. When TXEN is de-asserted, the **ICS1890** is unaffected by the state of TXD0.

Transmit Error TXER

When operating in the 100 Mbps mode, the assertion of Transmit Error (TXER) for one or more clock periods will cause the **ICS1890** to emit one or more invalid symbols. The signal must be synchronous with TXCLK. In the normal operating mode, a HALT symbol will be substituted for the next nibble decoded.

If the Invalid Error Code Test bit (16:2) is set, the 5-bit code group shown in the 4B5B encoding table will be substituted for the transmit data nibble presented.

The value of TXER during 10 Mbps operation has no effect on the **ICS1890**.

Receive Clock RXCLK

The Receive Clock (RXCLK) is sourced by the **ICS1890**. There are two possible sources for the Receive Clock (RXCLK). When a carrier is present on the receive pair, the source is the recovered clock from the data stream. When no carrier is present on the receive pair, the source is the Transmit Clock (TXCLK). In 10Base-T mode, the receive data pair will be quiescent during periods of inactivity and the Transmit Clock will be selected. In 100Base-T mode, the IDLE symbol is sent during periods of inactivity and the Recovered clock will be selected.

The **ICS1890** will only switch between clock sources when Receive Data Valid (RXDV) is de-asserted. During the period between Carrier Sense (CRS) being asserted and Receive Data Valid being asserted, a clock phase change of up to 360 degrees may occur. Following the de-assertion of Receive Data Valid a clock phase of 360 degrees may occur.

When Receive Data Valid is asserted, the Receive Clock frequency is 25% of the data rate, 2.5 MHz in 10Base-T mode and 25 MHz in 100Base-T mode. The **ICS1890** synchronizes Receive Data Valid, Received Data and Receive Error with Receive Clock (RXCLK).



ICS1890

Receive Data Valid

RXDV

Receive Data Valid (RXDV) is generated by the **ICS1890**. It indicates that the **ICS1890** is recovering and decoding data nibbles on the Receive Data (RXD) data lines synchronous with the Receive Data Clock (RXCLK). It is the responsibility of the MAC to frame the nibbles since the **ICS1890** has no knowledge of the frame structure and is merely a “nibble” processor. The **ICS1890** asserts RXDV when it detects and recovers the pre-amble or the start of stream delimiter (SSD) and de-asserts it following the last data nibble or upon detection of a signal error. RXDV is synchronous with the Receive Data Clock (RXCLK).

The assertion of Receive Error (RXER) for one or more clock periods during the period when RXDV is asserted (receiving a frame) indicates that the **ICS1890** has detected a read channel error. There are three sources of read channel error: loss of receive signal, failure of the PLL to lock and invalid symbol detection. RXER may also be asserted when RXDV is de-asserted. The **ICS1890** will assert RXER and set RXD(3:0) to 1110 if a false carrier is detected. For a good carrier to be detected, the **ICS1890** looks continuously at the incoming IDLE stream (1111...) for two non-contiguous logic zeroes and then checks for the SSD of “JK.” In the event that two non-contiguous logic zeroes are detected but the JK symbol pair is not, then a false carrier condition is signaled and the IDLE condition is re-entered.

Receive Data 3

RXD3

Receive Data 3 (RXD3) is the most significant bit of the receive data nibble. RXD is sourced by the **ICS1890**. When Receive Data Valid (RXDV) is asserted by the **ICS1890**, it will transfer the 4th bit of the symbol synchronously with Receive Clock (RXCLK).

Carrier Sense

CRS

The **ICS1890** asserts Carrier Sense (CRS) when it detects that either the transmit or receive lines are non-idle in half duplex mode. It is de-asserted when both the transmit and receive lines are idle in half duplex mode. CRS is not synchronous to either the transmit or receive clocks.

Receive Data 2

RXD2

Receive Data 2 (RXD2) is sourced by the **ICS1890**. When Receive Data Valid (RXDV) is asserted by the **ICS1890**, it will transfer the 3rd bit of the symbol synchronously with Receive Clock (RXCLK).

In full duplex mode and repeater mode, CRS is asserted only on receive activity.

Receive Data 1

RXD1

Receive Data 1 (RXD1) is sourced by the **ICS1890**. When Receive Data Valid (RXDV) is asserted by the **ICS1890**, it will transfer the 2nd bit of the symbol synchronously with Receive Clock (RXCLK).

Collision Detected

COL

The **ICS1890** asserts Collision Detected (COL) when it detects a receive carrier (non-idle condition) while transmitting (TXEN asserted).

Receive Data 0

RXD0

Receive Data 0 (RXD0) is the least significant bit of the receive data nibble. RXD0 is sourced by the **ICS1890**. When Receive Data Valid (RXDV) is asserted by the **ICS1890**, it will transfer the 1st bit of the symbol synchronously with Receive Clock (RXCLK).

In the 10 Mbps mode, the non-idle condition is detected by monitoring the unquelled receive signal. In the 100 Mbps mode, the non-idle condition is detected by two non-contiguous zeros in any 10-bit code group. COL is not synchronous to either the transmit or receive clocks.

In full duplex mode, COL is disabled and always remains low.

Receive Error

RXER

In 100 Mbps mode, the **ICS1890** detects two types of receive errors, errors occurring during the reception of valid frames and an error condition known as false carrier detect. False carrier detect is signaled so that repeater applications can prevent the propagation of false carrier detection. RXER always transitions synchronously with RXCLK.

In the 10 Mbps Node mode, COL will also be asserted as part of the signal quality error test (SQE). This behavior can be suppressed with the SQE Test Inhibit bit (18:2).

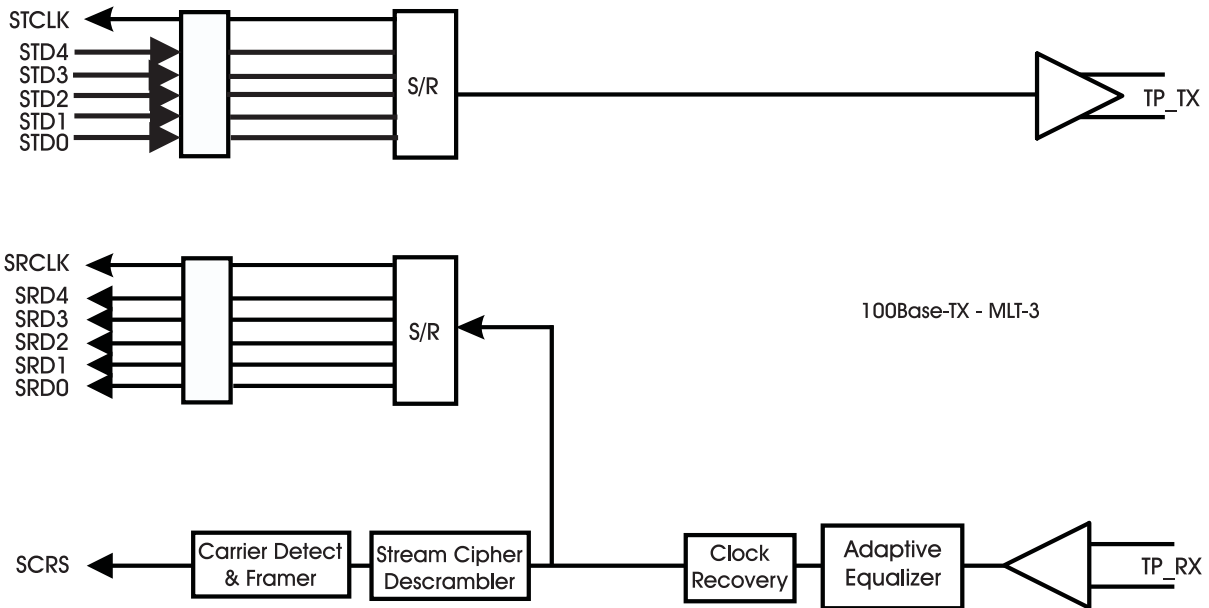

100M Stream Interface

100M Stream Interface - Pin Mapping

When the ICS1890 is operating in the stream mode, the MII Data Interface is remapped to accommodate the 100M Stream Interface. The following table details the exact pin mapping. Each individual pin description also contains the “new 100M Stream Interface pseudo pin name” followed by the real MII Data Interface pin name that it is mapped onto.

100M Stream Interface provides a lower latency parallel interface producing an AMD PDR/PDT and twister type 5 bit unscrambled interface when the data is scrambled by the upper layer.

<u>MII</u>	<u>Stream</u>
TXCLK	STCLK
TXEN	(1)
TXER	STD4
TXD3	STD3
TXD2	STD2
TXD1	STD1
TXD0	STD0
RXCLK	SRCLK
RXDV	(2)
RXER	SRD4
RXD3	SRD3
RXD2	SRD2
RXD1	SRD1
RXD0	SRD0
CRS	SCRS
COL	(3)
LSTA	SD



ICS1890

(1) 100Base-TX is a continuous transmission system and the MAC/Repeater is responsible for sourcing IDLE symbols when it is not transmitting data when using the Stream Interface.

(2) Since data is not framed when this interface is used, RXDV has no meaning.

(3) Since the MAC/Repeater is responsible for sourcing both active and idle data, the PHY can not tell when it is transmitting in the traditional sense so collisions can not be detected.

Other mode configuration pins behave identically regardless of which data interface is used.

Transmit Clock **STCLK/(TXCLK)**

The Transmit Clock (STCLK) is a continuous clock signal generated by the ICS1890 to synchronize the Transmit Data lines. In the 100M Stream Interface mode, the ICS1890 clock frequency is 25 MHz.

Transmit Data 4 **STD4/(TXER)**

Transmit Data 4 (STD4) is the most significant bit and is sampled continuously by the ICS1890 synchronously with the Transmit Clock.

Transmit Data 3 **STD3/(TXD3)**

Transmit Data 3 (STD3) is sampled continuously by the ICS1890 synchronously with the Transmit Clock.

Transmit Data 2 **STD2/(TXD2)**

Transmit Data 2 (STD2) is sampled continuously by the ICS1890 synchronously with the Transmit Data Clock.

Transmit Data 1 **STD1/(TXD1)**

Transmit Data 1 (STD1) is sampled continuously by the ICS1890 synchronously with the Transmit Clock.

Transmit Data 0 **STD0/(TXD0)**

Transmit Data 0 (STD0) (the least significant bit) is sampled continuously by the ICS1890 synchronously with the Transmit Clock.

Receive Clock **SRCLK/(RXCLK)**

The Receive Clock (SRCLK) is sourced by the ICS1890. There are two possible sources for the Receive Clock (SRCLK). When a carrier is present on the receive pair, the source is the recovered clock from the data stream. When no carrier is present on the receive pair, the source is the Transmit Clock (STCLK).

The Receive Clock frequency is 25 MHz in the 100M Stream Interface mode.

Receive Data 4 **SRD4/(RXER)**

Receive Error (SRD4) is the most significant bit of the receive data nibble and is continuously asserted by the ICS1890.

Receive Data 3 **SRD3/(RXD3)**

Receive Data 3 (SRD3) is continuously asserted by the ICS1890.

Receive Data 2 **SRD2/(RXD2)**

Receive Data 2 (SRD2) is continuously asserted by the ICS1890.

Receive Data 1 **SRD1/(RXD1)**

Receive Data 1 (SRD1) is continuously asserted by the ICS1890.

Receive Data 0 **SRD0/(RXD0)**

Receive Data 0 (SRD0) is the least significant bit of the receive data nibble.

Carrier Sense **SCRS/(CRS)**

Carrier Sense is provided in the 100M Stream Interface mode as a fast receive carrier look-ahead for optional application use. Carrier is detected using the same circuitry used in the MII Data Interface mode that is “bypassed” in this mode.

The ICS1890 asserts Carrier Sense (SCRS) when it detects that either the transmit or receive lines are non-idle in half duplex mode. It is de-asserted when both the transmit and receive lines are non-idle in half duplex mode. SCRS is not synchronous to either the transmit or receive clocks.

In full duplex mode and repeater mode, SCRS is asserted only on receive activity.

Signal Detect **SD/(LSTA)**

This signal is asserted when the PLL detects 100Base-T activity on the receive channel.



10M Serial Interface

10M Serial Interface - Pin Mapping

When the **ICS1890** is operating in the 10M Serial mode, the MII Data Interface is remapped to accommodate the 10M Serial Interface. The following table details the exact pin mapping. Each individual pin description also contains the “new 10M Serial Interface pseudo pin name” followed by the real MII Data Interface pin name that it is mapped onto.

<u>MI</u>	<u>10M Serial</u>
TXCLK	10TCLK
TXEN	10TXEN
TXER	(1)
TXD3	
TXD2	
XD1	
TXD0	10TD
RXCLK	10RCLK
RXDV	10RXDV
RXER	(1)
RXD3	
RXD2	
RXD1	
RXD0	10RD
CRS	10CRS
COL	10COL
LSTA	LSTA

(1) Error generation and detection is not supported by 10Base-T. Other mode configuration pins behave identically regardless of which data interface is used.

Transmit Clock **10TCLK/(TXCLK)**

The Transmit Clock (10TCLK) is a continuous clock signal generated by the **ICS1890** to synchronize the Transmit Data lines. In the 10M Serial Interface mode, the **ICS1890** clock frequency is 10 MHz.

Transmit Enable **10TXEN/(TXEN)**

Transmit Enable (10TXEN) indicates to the **ICS1890** that the MAC is sending valid data nibbles for transmission on the physical media. Synchronous with its assertion, the **ICS1890** will begin reading the serial data on the transmit data line. The **ICS1890** terminates transmission of data following the de-assertion of Transmit Enable.

Transmit Data **10TD/(TXD0)**

Transmit Data 0 (10TD) is the serial transmit data bit and is sampled continuously by the **ICS1890** synchronously with the Transmit Clock.

Receive Clock **10RCLK/(RXCLK)**

The Receive Clock (10RCLK) is sourced by the **ICS1890** and is 10 MHz in frequency. There are two possible sources for the Receive Clock. When a carrier is present on the receive pair, the source is the recovered clock from the data stream. When no carrier is present on the receive pair, the source is the Transmit Clock. In 10Base-T mode, the receive data pair will be quiescent during periods of inactivity and the Transmit Clock will be selected.

The **ICS1890** will only switch between clock sources when Receive Data Valid is de-asserted. During the period between Carrier Sense (CRS) being asserted and Receive Data Valid being asserted, a clock phase change of up to 360 degrees may occur. Following the de-assertion of Receive Data valid, a clock phase of 360 degrees may occur.

Receive Data Valid **10RXDV/(RXDV)**

Receive Data Valid (10RXDV) is generated by the **ICS1890**. It indicates that the **ICS1890** is recovering serial data on the Receive Data (10RD) line synchronous with the Receive Data Clock.

The **ICS1890** asserts RXDV when it detects and recovers the preamble or the start of stream delimiter (SSD) and de-asserts it following the last data nibble or upon detection of a signal error. RXDV is synchronous with the Receive Data Clock (10RCLK).

Receive Data **10RD/(RXD0)**

Receive Data 0 (10RD) is the received serial data stream.

Carrier Sense **10CRS/(CRS)**

The **ICS1890** asserts Carrier Sense (CRS) when it detects that either the transmit or receive lines are non-idle in half duplex mode. It is de-asserted when both the transmit and receive lines are idle in half duplex mode. CRS is not synchronous to either the transmit or receive clocks.

In full duplex mode and repeater mode, CRS is asserted only on receive activity.



ICS1890

Collision Detected **10COL/(COL)**

The **ICS1890** asserts Collision Detected (COL) when it detects a receive carrier (non idle condition while transmitting (TXEN asserted).

In the 10 Mbps mode, the non-idle condition is detected by monitoring the un-squelched receive signal. COL is not synchronous to either the transmit or receive clocks.

In full duplex mode, COL is disabled and always remains low.

In the 10 Mbps Node mode, COL will also be asserted as part of the signal quality error test (SQE). This behavior can be suppressed with the SQE Test Inhibit bit (18:2).

Link Pulse Interface

Link Pulse Interface - Pin Mapping

When the **ICS1890** is operating in the Link Pulse mode, the MII Data Interface is remapped to accommodate the Link Pulse Interface. The following table details the exact pin mapping. Each individual pin description also contains the “new Link Pulse Interface pseudo pin name” followed by the real MII Data Interface pin name that it is mapped onto.

<u>MII</u>	<u>Link Pulse</u>
TXCLK	LTCLK
TXEN	TXER
LPTX	
TXD3	
TXD2	
XD1	
TXD0	
RXCL	KLRLCLK
RXDV	
RXER	LPRX
RXD3	
RXD2	
RXD1	
RXD0	
CRS	
COL	
LSTA	SD

Other mode configuration pins behave identically regardless of which data interface is used.

Transmit Clock **LTCLK/(TXCLK)**

The Transmit Clock (10TCLK) is a continuous clock signal generated by the **ICS1890** with a frequency of 25 MHz.

Transmit Link Pulse **LPTX/(TXER)**

Data presented on this input will be transmitted as a Link Pulse of approximately the same duration.

Receive Clock **LRCLK/(RXCLK)**

The Receive Clock (LRCLK) is sourced by the **ICS1890** and is 25 MHz in frequency.

Receive Link Pulse **LPRX/(RXER)**

Receive activity that is qualified as a Link Pulse will be output on this pin as a high level of approximately the same duration as the Link Pulse.

Signal Detect **SD/(LSTA)**

This signal is asserted when the PLL detects 100Base-T activity on the receive channel.



MII Management Interface

Management Data Clock **MDC**

The Management Data Clock (MDC) is used by the **ICS1890** to synchronize the transfer of management information to or from the **ICS1890** using the serial MDIO data line.

Management Data Input/Output **MDIO**

The Management Data Input/Output (MDIO) is a tri-statable line driven by station management to transfer command information or driven by the **ICS1890** to transfer status information. All transfers and sampling are synchronous with MDC. If the **ICS1890** is to be used in an application which uses the mechanical MII specification, MDIO must have a $1.5K\Omega \pm 5\%$ pull-up at the **ICS1890** end and a $2K\Omega \pm 5\%$ pull-down at the station management end. This enables station management to determine if the connection is intact.

Twisted Pair Interface

Transmit Pair **TP_TX+ & TP_TX-**

The Transmit pair TP_TX+ and TP_TX- carries the serial bit stream for transmission over the UTP cable. The current-driven differential driver is programmed to produce two-level (10Base-T, Manchester) or three-level (100Base-TX, MLT-3) signals depending on the mode of operation selected (manually or by Auto-Negotiation). These output signals interface directly with an isolation transformer.

Note that these pins may be tristated using the TPTRI control pin.

Receive Pair **TP_RX+ & TP_RX-**

The Receive pair TP_RX+ and TP_RX- carries the serial bit stream from the mandatory isolation transformer. The serial bit stream may be two-level (10Base-T, Manchester) or three-level (100Base-TX, MLT-3) signals depending on the ICS mode of operation

10M Transmit Current Set Resistor **10TCSR**

A resistor is required to be connected between this pin and the nearest transmit ground to set the value of the transmit current used in 10M mode.

The value and tolerance of this resistor is specified in the Electricals section.

100M Transmit Current Set Resistor **100TCSR**

A resistor is required to be connected between this pin and the nearest transmit ground to set the value of the transmit current used in 100M mode.

The value and tolerance of this resistor is specified in the Electricals section.

Clock Reference Interface

Frequency Reference (**REF_IN & REF_OUT**)

These pins connect to the 25 MHz crystal or the frequency reference source.

When a frequency reference source like a crystal oscillator module is used, its output should be connected to REF_IN and REF_OUT should be left unconnected.

Configuration and Status Interface

Node/Repeater Mode **NOD/REP**

When this input is logic zero, the device will default to Node operation. SQE test will default to on for 10Base-T.

When this input is logic one, the device will default to Repeater operation. SQE test will default to off and Carrier Sense will be determined by receive activity only.

This pin setting also affects which clock, TXCLK or REF_IN, is used to latch the transmit data, TXD. See the description of the ITCLS pin for the details.

MII Data/Stream Interface Select **MII/SI**

This input pin selects the MAC to PHY interface to be used. When the input is low the MII Data Interface is selected.

When this input is high, the “Stream” Interface is selected. The “Stream” Interface that is used depends on the settings of the 10/100SEL and 10/LP pins which allow selection of the 100M Stream Interface, 10M/Serial Interface, or Link Pulse Interface.

10M Serial/Link Pulse Interface Select **10/LP**

This input selects between the 10M Serial and Link Pulse Interfaces when Stream Interface mode is selected with the MII/SI pin. When this input is low and Stream Interface mode is selected, the 10M Serial Interface is selected. When this input is high and Stream Interface mode is selected, the Link Pulse Interface is selected.



ICS1890

Hardware/Software Priority Select HW/SW

When this pin is logic zero, hardware pins have priority over software settings. The 10/100SEL pin becomes an input and controls speed selection. The DPXSEL pin becomes an input and controls duplex selection. The ANSEL pin becomes an input and chooses configuration with or without Auto-Negotiation.

When configuration through Auto-Negotiation is selected, the DPXSEL and 10/100SEL settings control the Auto-Negotiation register 4 default settings and Auto-Negotiation is enabled. When configuration without Auto-Negotiation is selected DPXSEL controls the duplex setting and 10/100SEL controls the data rate setting.

When this pin is a logic one, software bits have priority over hardware pin settings. The 10/100SEL pin becomes an output indicating the link speed when the link is established and parallels bit (17:15). The DPXSEL pin becomes an output indicating the link duplex state when the link is established and parallels bit (17:14). The ANSEL pin becomes an output indicating whether auto-negotiation is being used and parallels bit (0:12).

10/100 Select 10/100SEL

This pin is an input or an output depending on the setting of the HW/SW pin.

In HW mode, it is an input and controls speed selection directly or through Auto-Negotiation. When the input is low, 10Base-T is selected. When the input is high, 100Base-TX is selected.

In SW mode, this pin is an output and correctly reflects the selected speed when the link is established (LSTA is asserted). The output is low when 10Base-T is selected and high when 100Base-TX is selected which gives the same indication as register bit (17:15).

Note this pin also affects the MAC - PHY interface that is used in conjunction with the MII/SI pin.

Duplex Select DPXSEL

This pin is an input or an output depending on the setting of the HW/SW pin.

In HW mode, it is an input and controls duplex selection directly or through Auto-Negotiation. When the input is low, Half Duplex is selected. When the input is high, Full Duplex is selected.

In SW mode, this pin is an output and correctly reflects the selected duplex mode when the link is established (LSTA is asserted). The output is low when Half Duplex is selected and high when Full Duplex is selected which gives the same indication as register bit (17:14).

In Full Duplex mode, CRS is asserted only on receive activity. In Full Duplex mode, COL is disabled and always remains low.

Auto-Negotiation Select ANSEL

This pin is an input or output depending on the setting of the HW/SW pin.

In HW mode, it is an input and controls the enabling of Auto-Negotiation. When the input is low, Auto-Negotiation is disabled. When the input is high, Auto-Negotiation is enabled and the single technology selected by 10/100SEL and DPXSEL is advertised.

In SW mode, this pin is an output and reflects whether Auto-Negotiation has been enabled or disabled. The output is low when Auto-Negotiation is disabled and high when Auto-Negotiation is enabled which gives the same indication as register bit (0:12).

Invert Transmit Clock Latching Setting ITCLS~

The ICS1890 allows transmit data to be latched relative to either TXCLK or REF_IN. Latching the data to TXCLK is the behavior specified in the 100Base-T MII specification, but in some applications it is desirable to latch data with the REF_IN clock. An example of where this might be beneficial is in a repeater application where all data transmission on multiple 1890s need to be synchronized to a common clock.

To select the proper setting of this pin, first choose the setting of the NOD/REP pin. Then select the setting of the ITCLS pin that latches the transmit data with the clock of your choice. The following table shows the possible combinations. This pin has an internal pull-up so it may be left not connected for some applications.

NOD/REP	ITCLS	Latching Clock
NOD (0)	0	REF_IN
	1	TXCLK
REP (1)	0	TXCLK
	1	REF_IN



TP_TXTristate

When this pin is set to a logic zero, the twisted pair transmitter output pins will be enabled normally to source 100Base-TX or 10Base-T data.

When this pin is set to a logic one, the twisted pair transmitter output pins will be tristated.

MAC - PHY Receive Interface Tristate RXTRI

When this input is a logic zero the selected MAC-PHY interface behaves normally.

When this input is a logic one, the RXCLK, RXD[3:0], RXER, and RXDV pins are tristated. This allows repeater designs to bus the shared receive lines without requiring extra tristatable buffers on each port.

Note that the CRS and COL pins are not tristated. This allows repeater logic to use these signals to determine which receive port to enable.

Link Status

LSTA

This output reflects the current Link Status. It is similar to bit (1:2) but changes dynamically instead of latching on a link failure. The output is low when the link is invalid and is high when a valid link has been established.

When this bit is high, the 10/100SEL and DPXSEL bits can be observed to determine what type of link has been established.

Cipher Locked Status

LOCK

This output reflects the status of the Stream Cipher decoder block. When the Stream Cipher has not locked onto the incoming data stream, this output will be a logic zero. When the Stream Cipher has locked onto the incoming data stream, this output will be a logic one.

Note that the Stream Cipher will only lock onto 100Base-TX data (or IDLE symbols) and will not lock when 10Base-T data is present.

System Reset

RESET~

When grounded, this pin causes the ICS1890 to enter a reset/ low power state. On the low to high transition of RESET, the device will begin to complete its reset cycle. Upon completion, the ICS1890 will be initialized its default state.

While this pin is held low, the device is kept in its low power mode. Power savings and timings are shown in the Electricals section.

LED/PHY Address Usage

The ICS1890 device uses a unique pin sharing scheme that allows the 5 LED pins to also be used to set the PHY address. At power-up and reset they define the MII PHY address of the device. Subsequent to power-up and reset, they become LED status indicators.

The PHY address can be any number between 0 and 31. When PHY address 0 is used, the device's MII interface starts out Isolated and must be enabled through the MII management port (Reg 0 bit 10), as defined by the IEEE specification. All other addresses leave the MII interface active.

The actual value used for the individual PHY address bits depends on the configuration of the LED components. This is shown in the figure below. When a "1" value is desired the LED and resistor are connected between the LED pin and Vdd (LED Pin X). When a "0" value is desired the LED and resistor are connected between the LED pin and Ground (LED Pin Y). The special driver will sense the polarity and adjust its drive logic to appropriately turn the LED light on or off.

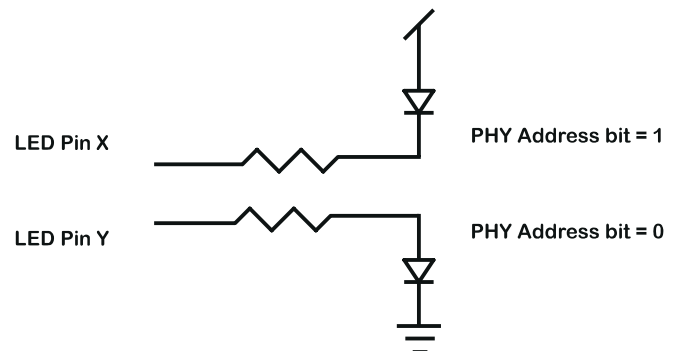

Resistor values should be in the range of 510Ω to 10kΩ. A 1kΩ resistor is recommended.

If LEDs are not required for the application, only a resistor is required to set the PHY address.

If LEDs are not required for the application and the ICS1890 will not be accessed with the serial MII management interface, then only a single resistor to VDD on any one of the LED pins is required. This will ensure that the PHY address is not zero, which would cause the ICS1890 to power up in the isolated state with no way for management to enable the MII interface.



ICS1890

Phy Address 4 - Receive Data LED P4RD

At power-up and reset, this pin is sampled for a logic high or zero. If a logic one is detected, a value of 16 is set in the configuration register.

The ICS1890 sets this bit to the appropriate value to turn on the LED when receive data is detected. This signal is stretched ensure that a single packet will be seen. If the packet stream is continuous, the LED will appear permanently on.

Phy Address 3 - Transmit Data LED P3TD

At power-up and reset, this pin is sampled for a logic high or zero. If a logic one is detected, a value of 8 is set in the configuration register.

The ICS1890 sets this bit to the appropriate value to turn on the LED when transmit data is detected. This signal is stretched to ensure that a single packet will be seen. If the packet stream is continuous, the LED will appear permanently on.

Phy Address 2 - Link Integrity LED P2LI

At power-up and reset, this pin is sampled for a logic high or zero. If a logic one is detected, a value of 4 is set in the configuration register.

The ICS1890 sets this bit to the appropriate value to turn on the LED when the Link Integrity status is OK.

Phy Address 1 - Collision LED P1CL

At power-up and reset, this pin is sampled for a logic high or zero. If a logic one is detected, a value of 2 is set in the configuration register.

The ICS1890 sets this bit to the appropriate value to turn on the LED when a collision is detected. This signal is stretched to ensure that a single collision will be seen. If the collisions are continuous, the LED will appear permanently on.

Phy Address 0 - Activity LED P0AC

At power-up and reset, this pin is sampled for a logic high or zero. If a logic one is detected, a value of 1 is set in the configuration register.

The ICS1890 sets this bit to the appropriate value to turn on the LED when either transmit or receive activity is detected. This signal is stretched to ensure that a single activity event will be seen. If the activity is continuous, the LED will appear permanently on.

Power Supply

These 7 VDD and 8 VSS pins supply power to the ICS1890 device.

ICS1890 Power Supply Isolation and Filtering

It is important to properly isolate the ICS1890 10/100Base-TX Physical Layer Device from noise sources in a system design. There are two key areas to consider, isolation from digital noise and noise coupling between the transmitter and receiver.

Filtering for the ICS1890 is accomplished by separating the power supply into three domains: digital, transmit, and receive. All supply pins on the device fall into one of these three categories as shown in the table below.

In the above table, each supply pin is followed directly by its ground pin. Each supply pair should be bypassed with a 0.1µF capacitor located as close to the device as possible.

Digital Domain	Transmit Domain	Receive Domain
41 VDD 40 VSS	8 VDD 7VSS	16 VDD 18 VDD 17 VSS
54 VDD 51 VSS	56 VDD 55 VSS	25 VDD 29 VSS
57 VDD 63 VSS		

The PCB board may have separate power and ground planes for the ICS1890. The power planes could be split into three domains following the pin isolation. A single, uniform plane should be used for ground. Power plane placement is illustrated in the figure below.

Point-to-point trace routing for power connections may be used instead of actual power “planes” if required by printed circuit board constraints.

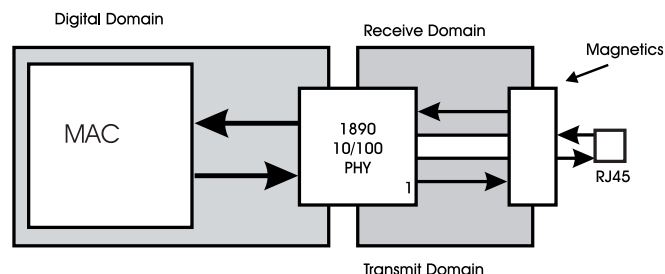

Both the Receive and Transmit Domains should be connected to the Digital Domain or main supply through a ferrite bead or inductor, with a value of 1µH to 1µH. The best filter configuration is a pi filter composed of a .1µH capacitor, .1µH ferrite bead, and a .1µH capacitor at the device pin.

Reserved & N/C Pins

Four pins are labeled “Reserved” or “N/C.” These pins should be left unconnected. Connecting these pins to ground or power may prevent the device from operating properly



Pin Descriptions

PIN NUMBER	PIN NAME	I/O	TYPE	Description
1	NOD/REP	I	TTL-compatible	Node/Repeater Mode
2	10/100SEL	I/O	TTL-compatible	10/100 Select
3	10TCSR	I		10M Transmit Current Set Resistor
4	100TCSR	I		100M Transmit Current Set Resistor
5	TP_TX	O		Twisted Pair Transmit Data+
6	TP_TX-	O		Twisted Pair Transmit Data-
7	VSS			
8	VDD			Digital Domain Power (Transmitter)
9	TPTRI	I	TTL-compatible	Twisted Pair Tristate
10	TP_RX+	I		Twisted Pair Receive Data+
11	TP_RX-	I		Twisted Pair Receive Data-
12	N/C			
13	ITCLS~	I	TTL-compatible	Invert Transmit Clock Latching Setting
14	N/C			
15	N/C			
16	VDD			Receive Domain Power (Receiver)
17	VSS			
18	VDD			Receive Domain Power (Receiver)
19	MII/SI	I	TTL-compatible	MII Data/Stream Interface
20	REG	I	TTL-compatible	Ground for high order register access
21	LSTA*	O	TTL-compatible	Link Status
22	RESET~	I	TTL-compatible	System Reset
23	HW/SW	I	TTL-compatible	Hardware/Software Priority
24	DPXSEL	I/O	TTL-compatible	Duplex Select
25	VDD			Receive Domain Power (RPLL)
26	N/C			
27	LOCK	O	TTL-compatible	Cipher Lock
28	10/LP	I	TTL-compatible	10M Serial/Link Pulse Interface
29	VSS			
30	MDIO	I/O	TTL-compatible	Management Data Input/Output
31	MDC	I	TTL-compatible	Management Data Clock
32	RXD3*	O	TTL-compatible	Receive Data 3

* Redefined for other MAC-PHY interfaces.



ICS1890

Pin Descriptions

PIN NUMBER	PIN NAME	I/O	TYPE	DESCRIPTION
33	RXD2*	O	TTL-compatible	Receive Data 2
34	RXD1*	O	TTL-compatible	Receive Data 1
35	RXD0*	O	TTL-compatible	Receive Data 0
36	RXDV*	O	TTL-compatible	Receive Data Valid
37	RXCLK*	O	TTL-compatible	Receive Clock
38	RXER	O	TTL-compatible	Receive Error
39	RXTRI	I	TTL-compatible	Receive MAC-PHY Interface Tristate
40	VSS			
41	VDD			Digital Domain Power
42	TXER*	I	TTL-compatible	Transmit Error
43	TXCLK*	O	TTL-compatible	Transmit Error
44	TXEN*	I	TTL-compatible	Transmit Enable
45	TXD0*	I	TTL-compatible	Transmit Data 0
46	TXD1*	I	TTL-compatible	Transmit Data 1
47	TXD2*	I	TTL-compatible	Transmit Data 2
48	TXD3*	I	TTL-compatible	Transmit Data 3
49	COL*	O	TTL-compatible	Collision Detect
50	CRS*	O	TTL-compatible	Carrier Sense
51	VSS			
52	REF_OUT	O		Frequency Reference Output
53	REF_IN	I	CMOS-compatible	Frequency Reference Input
54	VDD			Digital Domain Power
55	VSS			
56	VDD			Transmit Domain Power (TPLL)
57	VDD			Digital Domain Power
58	P0AC	I/O	LED	Special PHY ID 0/Activity LED
59	P1CL	I/O	LED	Special PHY ID 1/Collision det LED
60	P2LI	I/O	LED	Special PHY ID 2/Link Integrity LED
61	P3TD	I/O	LED	Special PHY ID 3/Transmit data LED
62	P4RD	I/O	LED	Special PHY ID 4/Receive data LED
63	VSS			
64	ANSEL	I/O	TTL-compatible	Auto-Negotiation Select

* Redefined for other MAC-PHY interfaces.



Pin Configuration

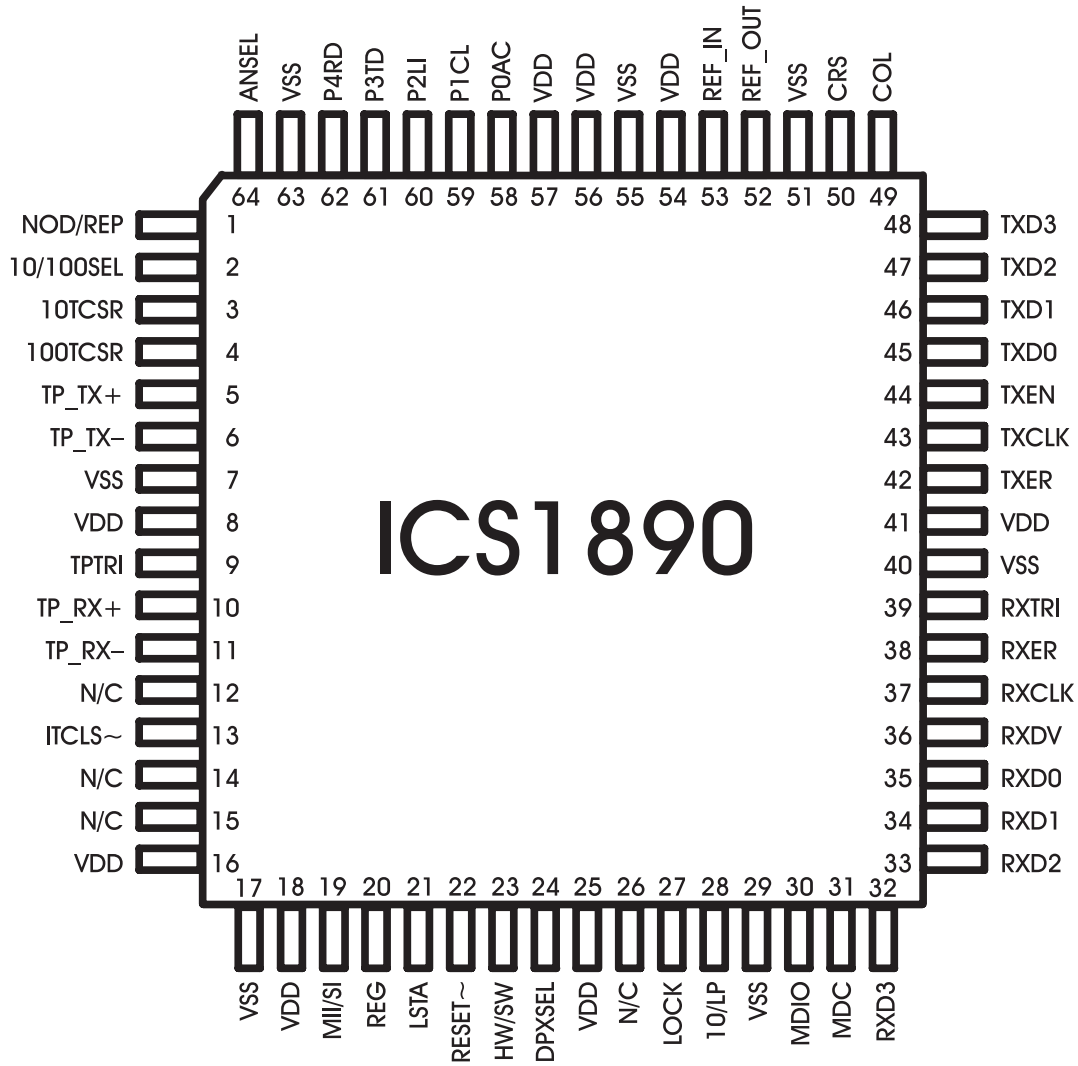



ICS1890

Absolute Maximum Ratings

V_{DD} (measured to V_{SS}) 7.0V
 Digital Inputs/Outputs $V_{SS}-0.5$ to $V_{DD}+0.5V$
 Storage Temperature. -65 to 150°C
 Junction Temperature 175°C
 Soldering Temperature 260°C

Stresses above those listed under Absolute Maximum Ratings may cause permanent damage to the device. This is a stress rating only and functional operation of the device at these or any other conditions above those indicated in the operational sections of the specifications is not implied. Exposure to absolute maximum rating conditions for extended periods may affect product reliability. Electrical parameters are guaranteed only over the recommended operating temperature range.

Recommended Operating Conditions

PARAMETER	SYMBOL	TEST CONDITIONS	MIN	MAX	UNITS
Ambient Operating Temp.	TA		0	+70	°C
Power Supply	VSS VDD		0.0 +4.75	0.0 +5.25	V V

Recommended Component Values

PARAMETER	MIN	TYP	MAX	UNITS
Crystal Oscillator Frequency*		25		MHz
Crystal Oscillator Frequency Tolerance	-50		+50	ppm
10TCSR Resistor Value	1.4	2.0	2.61	KΩ
100TCSR Resistor Value	6.49	6.81	7.50	KΩ
LED Resistor Value	510	1000	10,000	Ω

* CMOS output drive recommended

Note: This matches the IEEE requirement in the 100Base-X standard definition for the code-bit-timer (24.2.3.4) which is more stringent than the basic media independent interface (MII) specification for the TX_CLK of ±100ppm (22.2.2.1).



DC Characteristics

$V_{DD} = V_{MIN}$ to V_{MAX} , $V_{SS} = 0V$, $T_A = T_{MIN}$ to T_{MAX}

PARAMETER	SYMBOL	CONDITIONS	MIN	MAX	UNITS
IC Supply Current	I_{DD}	$V_{DD}=5.25V$	-	195	mA

TTL Input/Output

PARAMETER	SYMBOL	CONDITIONS	MIN	MAX	UNITS
TTL Input High Voltage	V_{IH}	$V_{DD}=5V, V_{SS}=0V$	2.0	-	V
TTL Input Low Voltage	V_{IL}	$V_{DD}=5V, V_{SS}=0V$	-	0.8	V
TTL Output High Voltage	V_{OH}	$V_{DD}=5V, V_{SS}=0V$	2.4	-	V
TTL Output Low Voltage	V_{OL}	$V_{DD}=5V, V_{SS}=0V$	-	0.4	V
TTL Driving CMOS, Output High Voltage	V_{OH}	$V_{DD}=5V, V_{SS}=0V$	3.68	-	V
TTL Driving CMOS, Output Low Voltage	V_{OL}	$V_{DD}=5V, V_{SS}=0V$	-	0.4	V
TTL/CMOS Output Sink Current	I_{OL}	$V_{DD}=5V, V_{SS}=0V$	8	-	mA
TTL/CMOS Output Source Current	I_{OH}	$V_{DD}=5V, V_{SS}=0V$	-	-0.4	mA

REF_IN Input

PARAMETER	SYMBOL	CONDITIONS	MIN	MAX	UNITS
Input High Voltage	V_{IH}	$V_{DD}=5V, V_{SS}=0V$	3.5	-	V
Input Low Voltage	V_{IL}	$V_{DD}=5V, V_{SS}=0V$	-	1.5	V

Note: REF_IN Input switch point is 50% of VDD.

PARAMETER (condition)	MIN	TYP	MAX	UNITS
MII Input Pin Capacitance	-	8	-	pF
MII Output Pin Capacitance	-	14	-	pF
MII Output Pin Impedance	-	38	-	Ohms

Note: Total system operating current will include load current required by the Tx transformer.



ICS1890

Clock - Reference In (REF_IN)

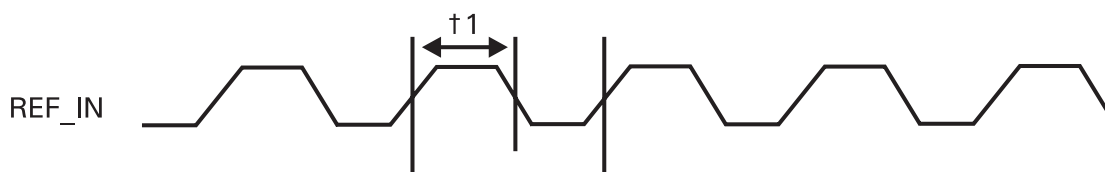

T#	PARAMETER (condition)	MIN	TYP	MAX	UNITS
t1	REF_IN Duty Cycle	45	50	55	%
t2	REF_IN Period	-	40	-	ns

Note: REF_IN switching point is 50% of VDD.



MII - Transmit Clock Tolerance

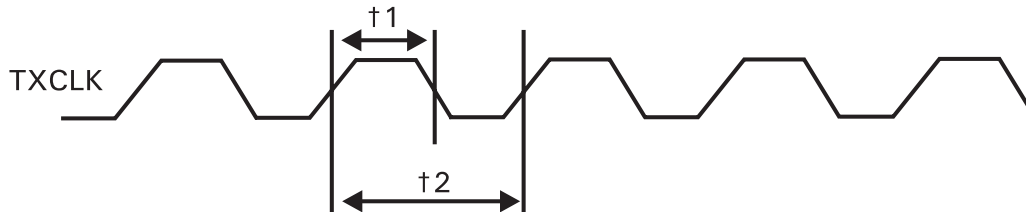

T#	PARAMETER (condition)	MIN	TYP	MAX	UNITS
t1	TXCLK Duty Cycle	35	50	65	%
t2a	TXCLK Period (100Base-T/MII Interface)	-	40	-	ns
t2b	TXCLK Period (10Base-T/MII Interface)	-	400	-	ns
t2c	TXCLK Period (100Base-T/100M Stream Interface)	-	40	-	ns
t2d	TXCLK Period (10Base-T/10M Serial Interface)	-	100	-	ns

Note: TXCLK Duty Cycle = REF_IN Duty Cycle ±5%.

MII - Receive Clock Behavior

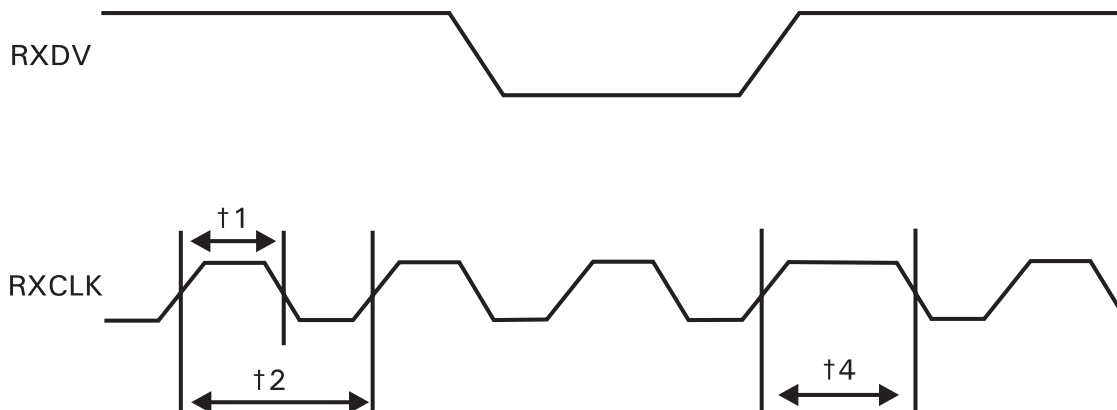

T#	PARAMETER (condition)	MIN	TYP	MAX	UNITS
t1	RXCLK Duty Cycle	45	50	55	%
t2a	RXCLK Period (100Base-T/MII Interface)	-	40	-	ns
t2b	RXCLK Period (10Base-T/MII Interface)	-	400	-	ns
t2c	RXCLK Period (100Base-T/100M Stream Interface)	-	-	40	ns
t2d	RXCLK Period (10Base-T/10M Serial Interface)	-	-	100	ns
t4	RXDV Asserted Nominal Clock to Recovered Clock Cycle Extension	-	-	65	ns



ICS1890

MII/100M Stream - Synchronous Transmit Timing

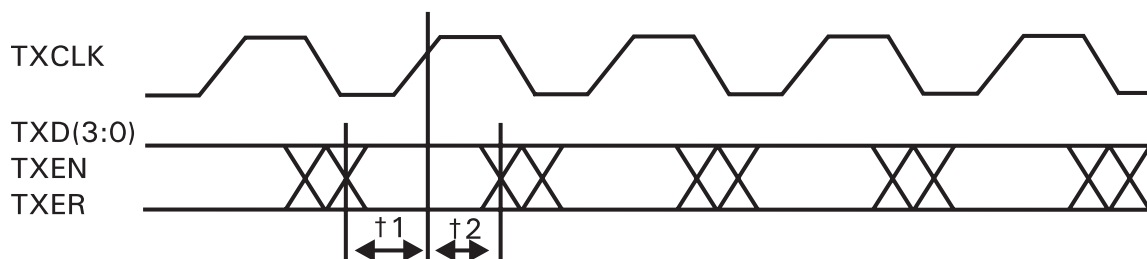

T#	PARAMETER (condition)	MIN	TYP	MAX	UNITS
t1	TXD, TXEN, TXER Setup to TXCLK rise	10	-	-	ns
t2	TXD, TXEN, TXER Hold after TXCLK rise	0	-	-	ns

Note: With ITCLS low (or in repeater mode) timing is with respect to REF_IN

MII/100M Stream - Synchronous Receive Timing

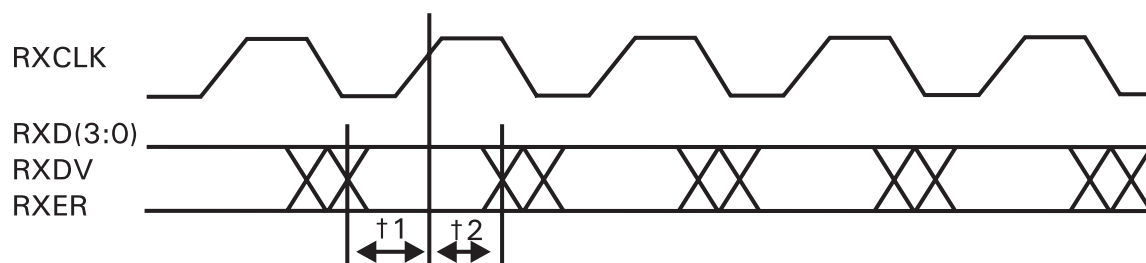

T#	PARAMETER (condition)	MIN	TYP	MAX	UNITS
t1	RXD, RXDV, RXER Setup to RXCLK rise	10.0	-	-	ns
t2	RXD, RXDV, RXER Hold after RXCLK rise	10.0	-	-	ns



MII - Management Interface Timing

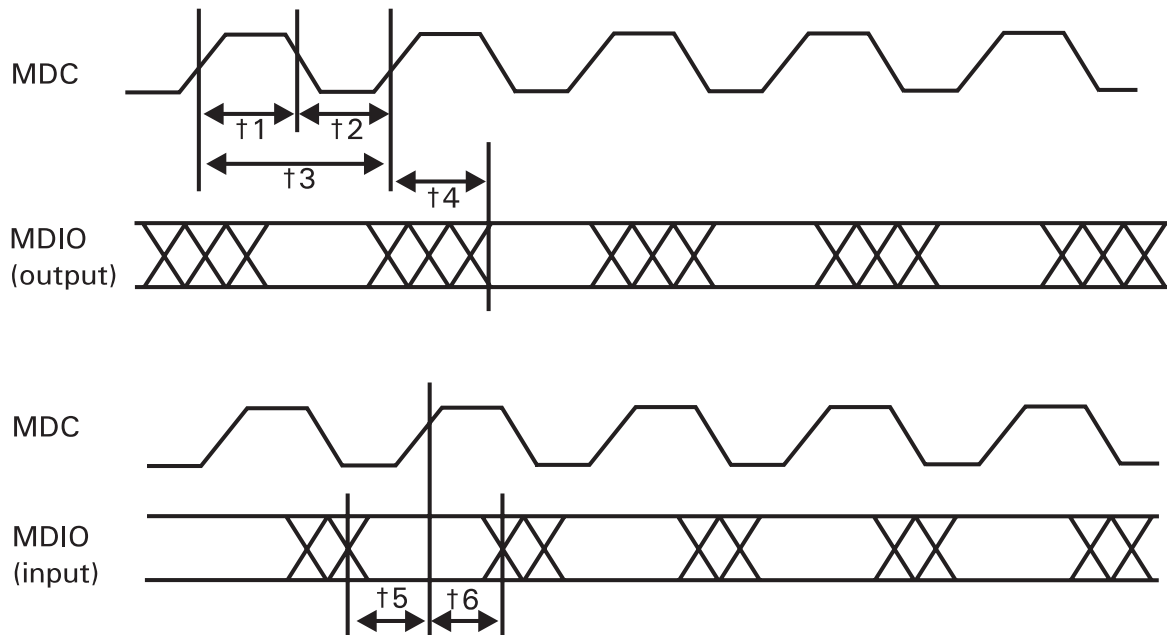

T#	PARAMETER (condition)	MIN	TYP	MAX	UNITS
t1	MDC Minimum High Time	160	-	-	ns
t2	MDC Minimum Low Time	160	-	-	ns
t3	MDC Period	400	-	-	ns
t4	MDC rise to MDIO valid	0	-	300	ns
t5	MDIO Setup to MDC	10	-	-	ns
t6	MDIO Hold after MDC	10	-	-	ns
t7	Maximum allowable frequency (50pF Loading)	-	-	10	MHz



ICS1890

Receive Latency (10M Serial)

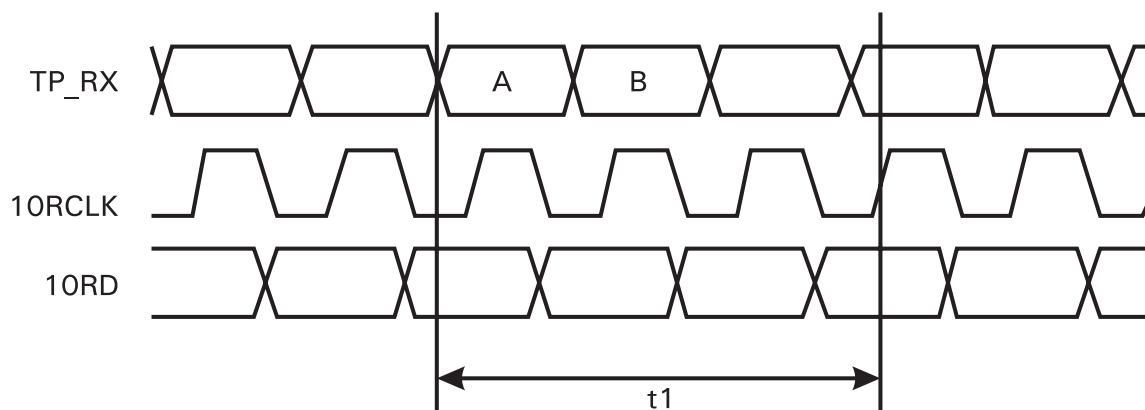

T#	PARAMETER (condition)	MIN	TYP	MAX	UNITS
t1	TP_RX input to 10RD delay (10M Serial Interface)	15	-	16.5	bits

Receive Latency (10M MII)

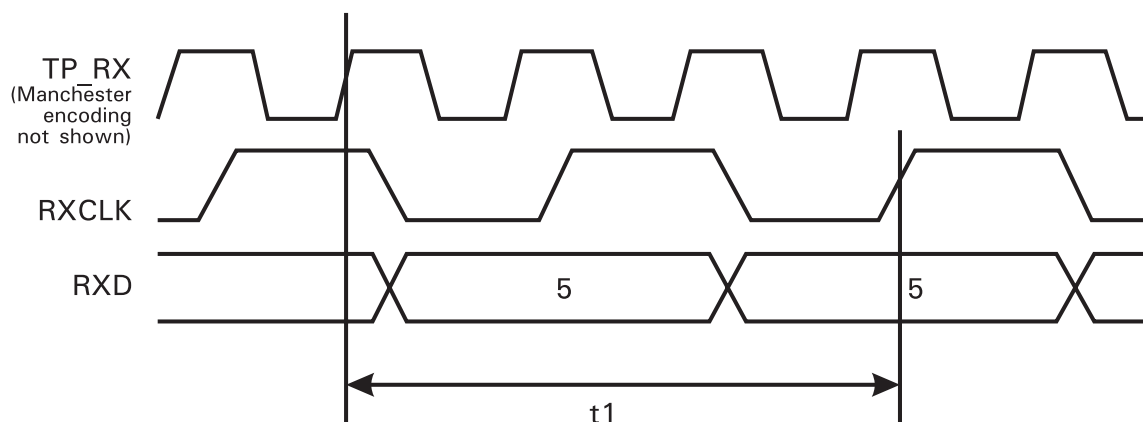

T#	PARAMETER (condition)	MIN	TYP	MAX	UNITS
t1	1st bit of /5/ on TP_RX to /5/ on RXD (10M MII)	18	-	19.5	bits



Transmit Latency (10M Serial)

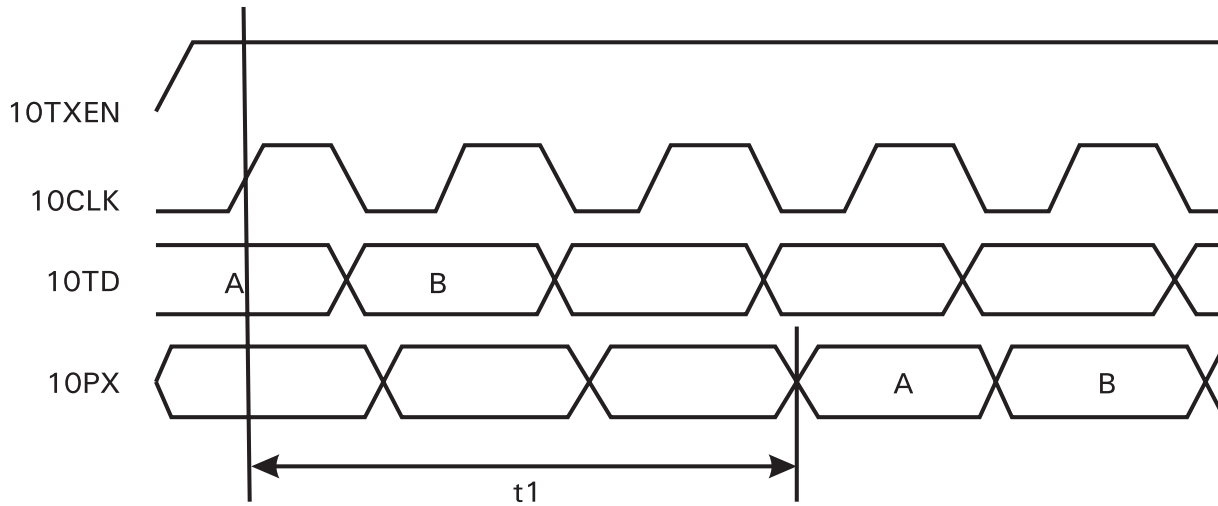

T#	PARAMETER (condition)	MIN	TYP	MAX	UNITS
t1	10TD in to TP_TX out delay (10M Serial Interface)	-	1.5	-	bits

Transmit Latency (10M MII)

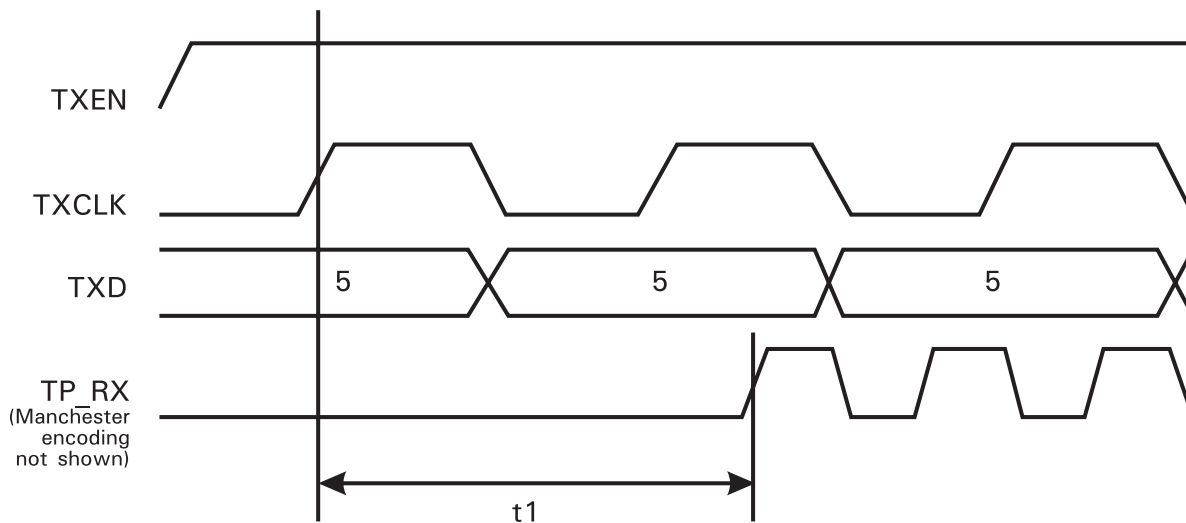

T#	PARAMETER (condition)	MIN	TYP	MAX	UNITS
t1	TXD sampled to MDI Output of 1st bit (10M MII)	-	1.5	-	bits



ICS1890

Transmit Latency (MII/100M Stream)

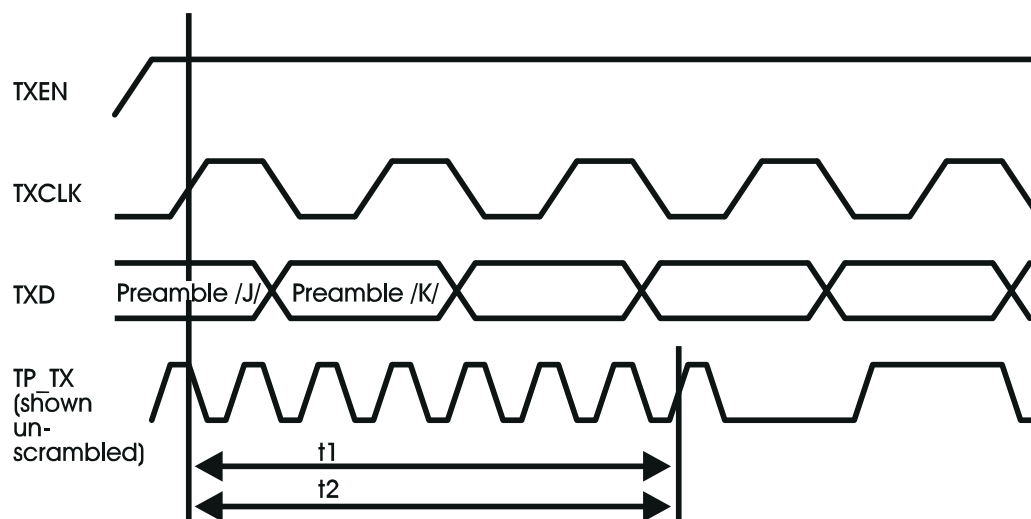

T#	PARAMETER (condition)	MIN	TYP	MAX	UNITS
t1	TXEN sampled to MDI Output 1st bit of /J/ (MII IF)*	-	-	4BT	bits
t2	TXD sampled to MDI Output of 1st bit (100M Stream IF)	-	-	5	bits

* Note that the IEEE maximum is 18 bits.



MII - CarrierAssertion/De-assertion on Transmission

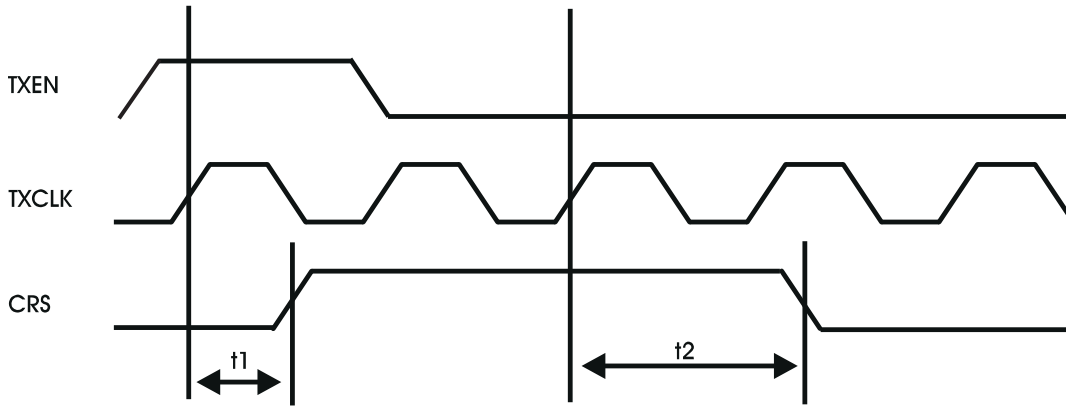

T#	PARAMETER (condition)	MIN	TYP	MAX	UNITS
t1	TXEN sampled to CRS assert	0	-	4	bits
t2	TXD sampled to CRS de-assert	0	-	4	bits

MII - Receive Latency (MII/100M Stream)

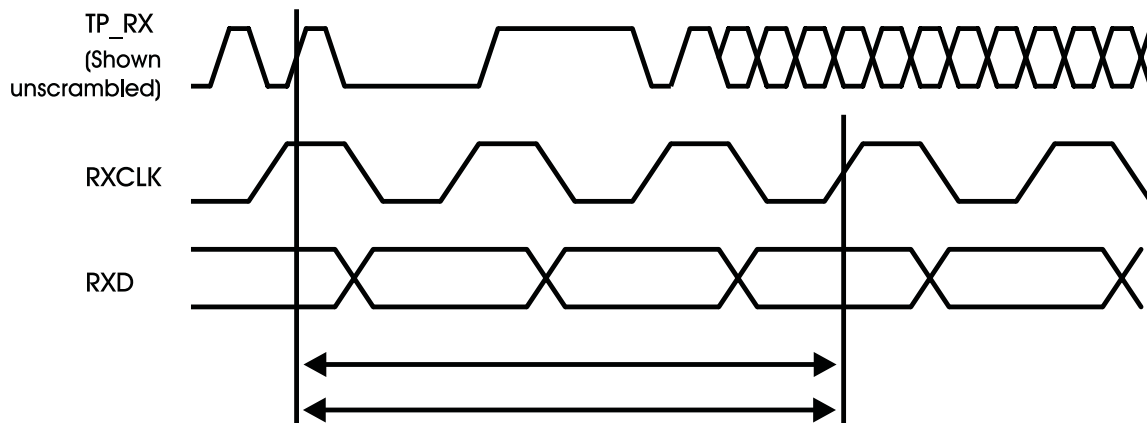

T#	PARAMETER (condition)	MIN	TYP	MAX	UNITS
t1	1st bit of /J/ into TP_RX to /J/ on RXD (100M MII IF)	-	-	19BT	bits
t2	1st bit of /J/ into TP_RX to /J/ on RXD (100M Stream IF)	-	-	12.5	bits

* Note that the IEEE maximum is 23 bits.



ICS1890

MDI Input to Carrier Assertion/De-assertion

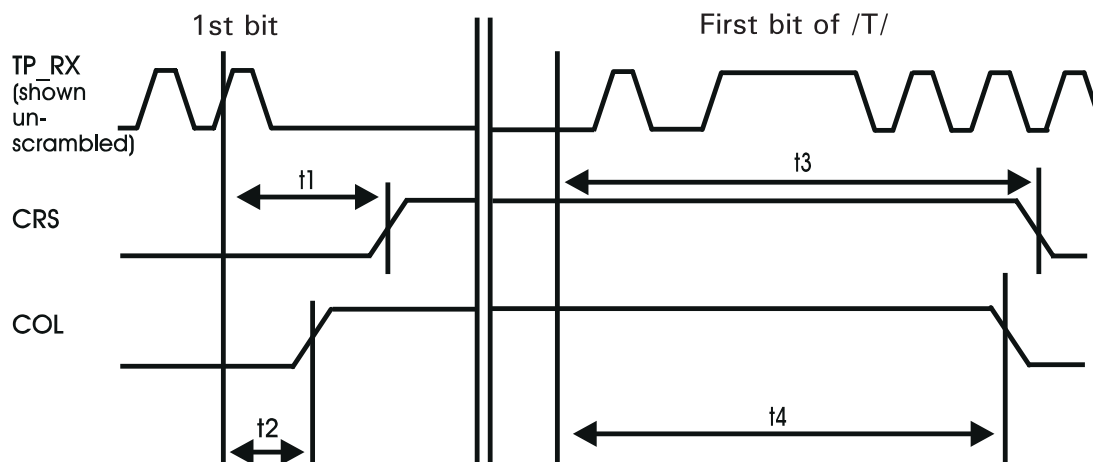

T#	PARAMETER (condition)	MIN	TYP	MAX	UNITS
t1	1st bit of /J/ into TP_RX to CRS assert*	-	-	124ns/13BT	bits
t2	1st bit of /J/ into TP_RX while transmitting data to COL assert (Half Duplex Mode)*	-	-	13	bits
t3	First bit of /T/ into TP_RX to CRS de-assert**	-	-	130ns/13BT	bits
t4	First bit of /T/ received into TP_RX to COL de-assert (Half Duplex Mode)**	-	-	14	bits

* Note that the IEEE maximum is 20 bit times.

** Note that the IEEE minimum is 13 bit times and the maximum is 24 bit times.



Reset - Power on Reset

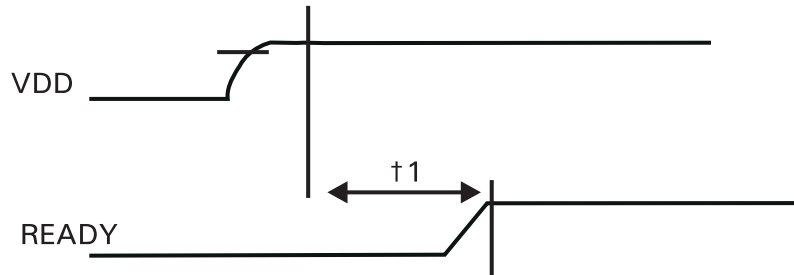

T#	PARAMETER (condition)	MIN	TYP	MAX	UNITS
t1	VDD to 4.5V to Reset Complete	-	-	20	μs

Reset - Hardware Reset & Power-down

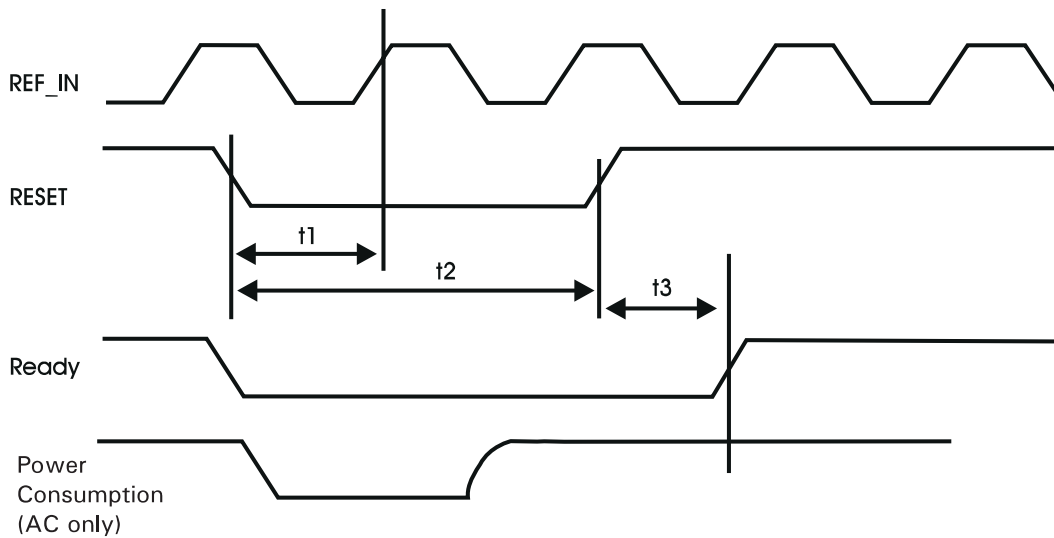

T#	PARAMETER (condition)	MIN	TYP	MAX	UNITS
t1	RESET active to device isolation and initialization	-	-	200	ns
t2	Minimum RESET pulse width	80	-	-	ns
t3	RESET released to device ready	-	-	640	ns



ICS1890

10Base-T Heartbeat Timing

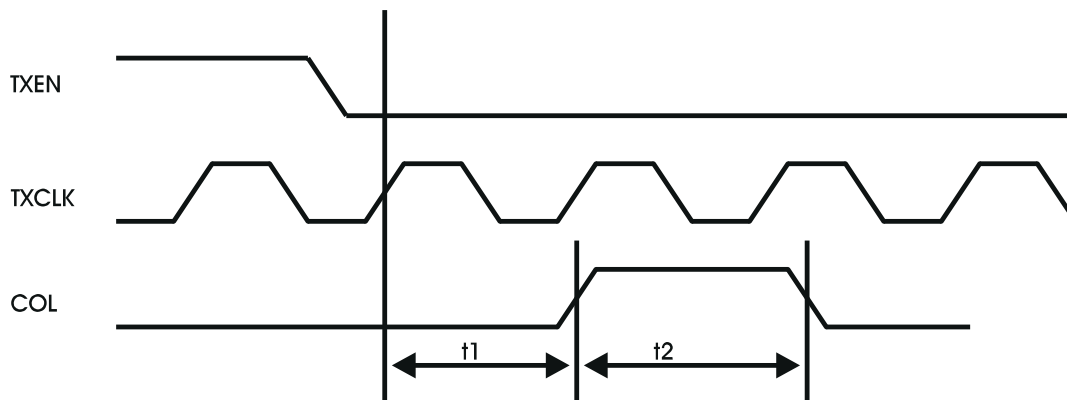

T#	PARAMETER (condition)	MIN	TYP	MAX	UNITS
t1	COL Heartbeat assertion delay from TXEN de-assertion (10Base-T Half Duplex)	-	-	1210	ns
t2	COL Heartbeat assertion duration (10Base-T Half Duplex)	-	-	1170	ns

10Base-T Jabber Timing

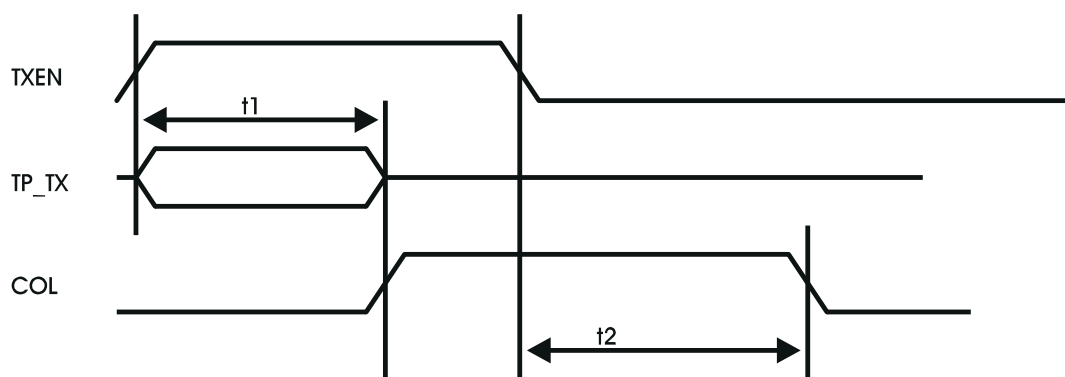

T#	PARAMETER (condition)	MIN	TYP	MAX	UNITS
t1	Jabber activation time (10Base-T Half Duplex)	-	26	-	ms
t2	Jabber deactivation time (10Base-T Half Duplex)	-	410	-	ms



10Base-T Normal Link Pulse Timing

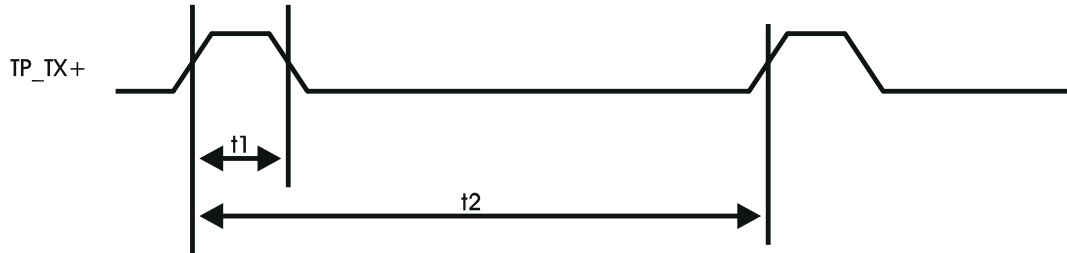

T#	PARAMETER (condition)	MIN	TYP	MAX	UNITS
t1	Normal Link Pulse Width (10Base-T)	-	100	-	ns
t2	COL Heartbeat assertion duration (10Base-T Half Duplex)	8	-	24	ms

Auto-Negotiation Fast Link Pulse Timing

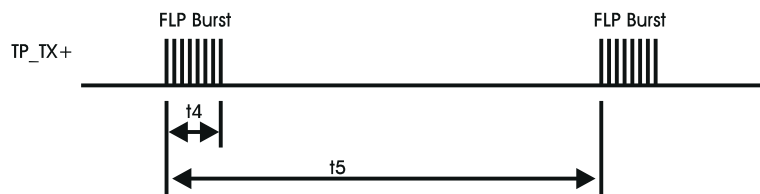
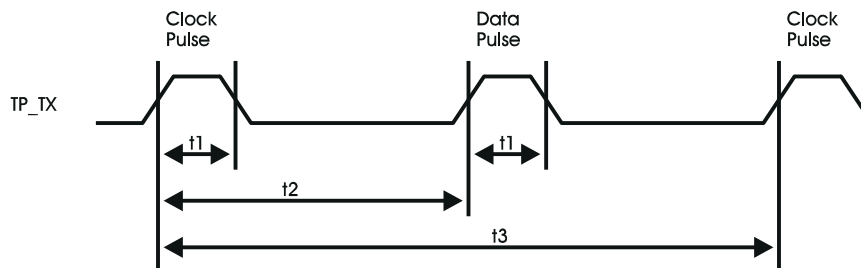

T#	PARAMETER (condition)	MIN	TYP	MAX	UNITS
t1	Clock/Data pulse width	-	100	-	ns
t2	Clock pulse to Data pulse timing	55.5	62.5	69.5	μs
t3	Clock pulse to Clock pulse	111	125	139	μs
t4	FLP Burst width	-	2	-	ms
t5	FLP burst to FLP burst timing	8	16	24	ms
t6	Number of Clock/Data pulses in a burst	17	-	33	pulses



ICS1890

Clock Recovery

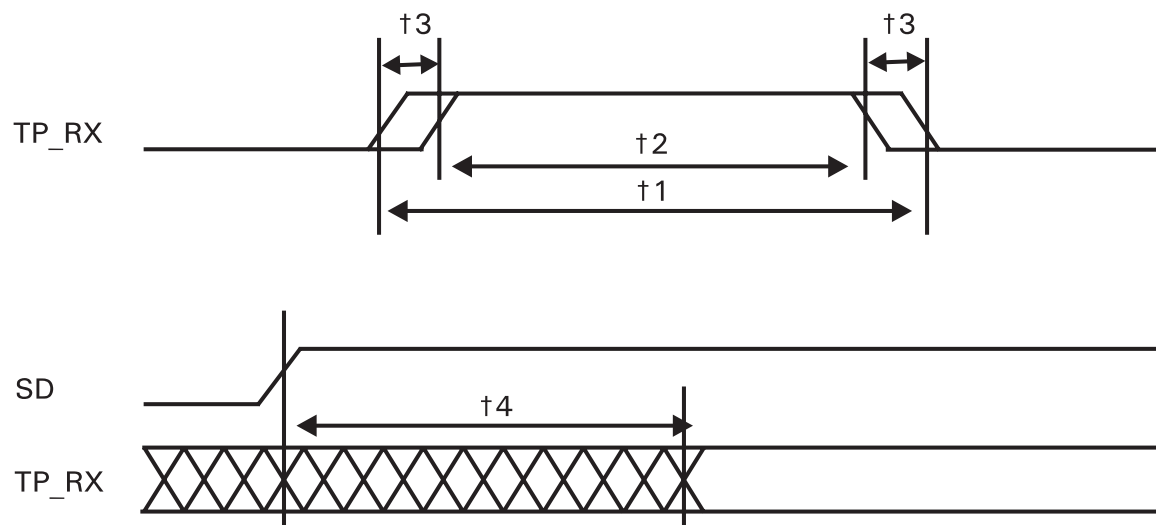

T#	PARAMETER (condition)	MIN	TYP	MAX	UNITS
t1	Ideal data recovery window	-	-	8	ns
t2	Actual data recovery window	6	-	8	ns
t3	Data recovery window truncation	0	-	1	ns
t4	SD assert to data acquired	-	-	100	ns

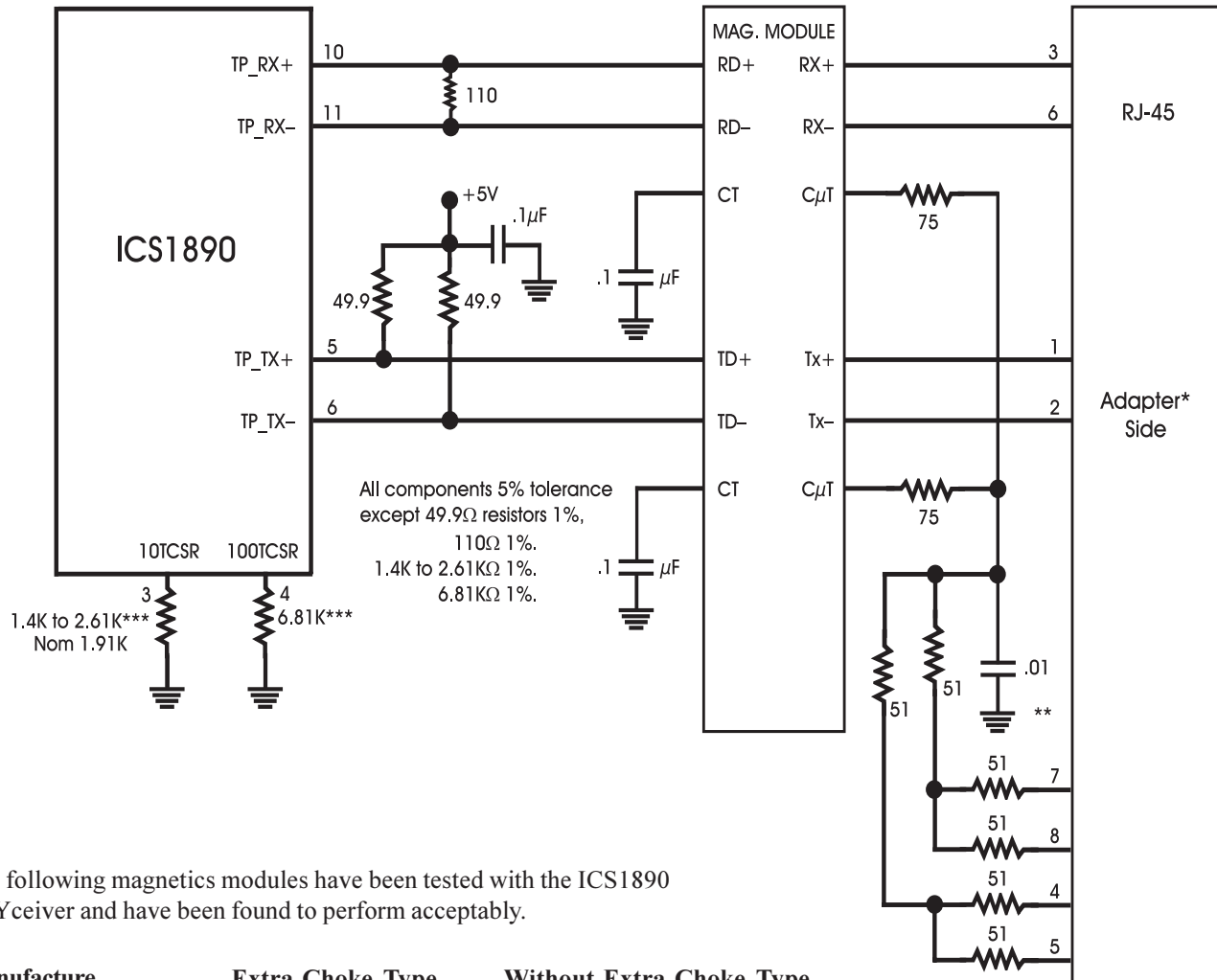

The following magnetics modules have been tested with the ICS1890 PHYceiver and have been found to perform acceptably.

Manufacture	Extra Choke Type	Without Extra Choke Type
Nano Pulse (NPI)	NP16120-30	NP16170-30
Pulse	PE-68517	PE-68515
Valor	ST6114	STG118
Bell Fuse	S558-5999-01	S558-5999-00
Halo	TG22-SO10ND	TG22-SO20ND
Innet	T0027S	T0019S
Unicom	2HT16-27	

* Repeaters and Hubs are generally responsible for including a cable crossover. One way of doing this is to exchange transmit (1 & 2) and receive (3 & 6) connections to the RJ-45.

** A minimum of 2KV capacitor should be used to make the connection to the chassis ground.

*** These are close starting values. These resistors need to be tailored to individual system insertion losses, these values can go as low as 1KΩ. Average 10TCSR value (pin 3) is 1.91KΩ.



ICS1890

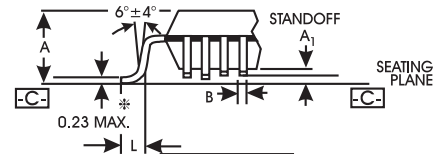
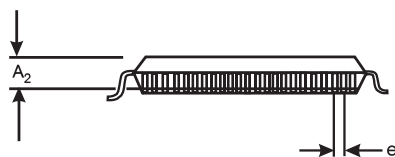
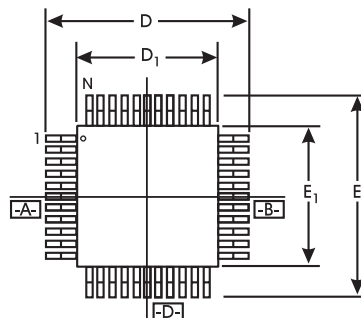

TQFP/MQFP Package

DIMENSION NAME	LEAD COUNT (N) 64L			TQFP	MQFP
	BODY THICKNESS			1.4	2.7
	FOOTPRINT (BODY+) Nominal			2.0	3.20
	DIMENSIONS	TOLERANCE TQFP	TOLERANCE MQFP		
Full Package Height	A	MAX.	MAX.	1.60	3.00
Package Standoff	A1	MAX.	MAX.	0.15	0.25
Package Thickness	A2	±0.05	+0.10/-0.05	1.4	2.7
Tip-to-Tip Width	D	BASIC	±0.25	16.0	17.20
Body Width	D1	BASIC	±0.10	14.0	14.00
Tip-to-Tip Width	E	BASIC	±0.25	16.0	17.20
Body Width	E1	BASIC	±0.10	14.0	14.00
Footlength	L	±0.15	+0.10/-0.10	0.60	0.88
Lead Pitch	e	BASIC	BASIC	0.80	0.80
Lead Width w/Plate	B	+0.08/-0.05	+0.10/-0.05	0.37	0.35
Lead Height w/Plate	*	+0.04/-0.07	MAX.	0.16	0.23

Dimensions in millimeters.

Ordering Information

ICS1890Y

ICS1890Y-14

Example:

ICS XXXXY

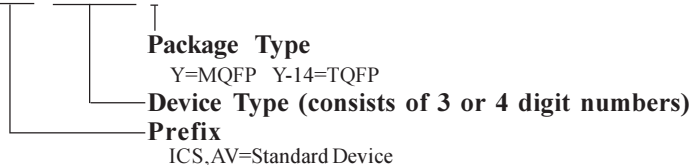



LittleDiode supplies new, hard to find or obsolete electronic components and semiconductors all over the world.

With over two million different components listed you are sure to find the part you need.

Feel free to visit us today at our online store:

LittleDiode.com

Looking forward to providing you with the best possible service.