



Description

The ICS551 is a low cost, high speed single input to four output clock buffer. Part of ICS' Clock Blocks™ family, this is our lowest cost, small clock buffer. See the ICS552-01B for a monolithic dual version of the ICS551 in a 20 pin QSOP.

ICS makes many non-PLL and PLL based low skew output devices, as well as Zero Delay Buffers to synchronize clocks. Contact us for all of your clocking needs.

Features

- Packaged in 8 pin SOIC
- Low cost clock buffer
- Low skew (250ps) outputs
- Input/output clock frequency up to 160 MHz
- Operating voltages of 3.0 to 5.5 V
- Non-inverting
- Ideal for networking clocks
- Output Enable mode tri-states outputs
- Full CMOS clock swings with 25mA drive capability at TTL levels
- Advanced, low power CMOS process



Block Diagram

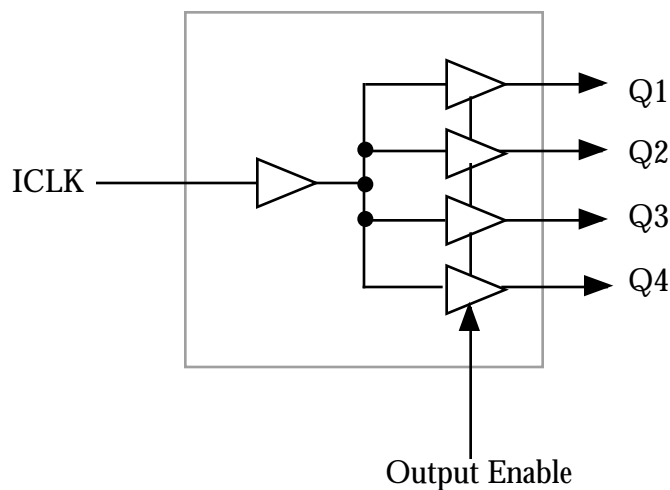



Pin Assignment

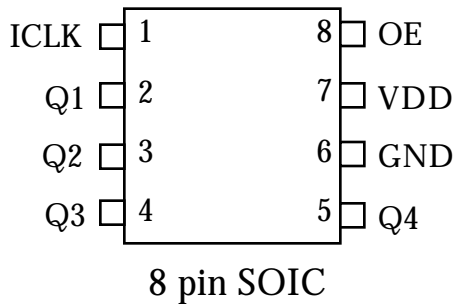

Pin Descriptions

Number	Name	Type	Description
1	ICLK	CI	Clock input. Internal pull-up resistor.
2	Q1	O	Clock Output 1.
3	Q2	O	Clock Output 2.
4	Q3	O	Clock Output 3.
5	Q4	O	Clock Output 4.
6	GND	P	Connect to ground.
7	VDD	P	Connect to +3.3 V or +5.0 V.
8	OE	I	Output Enable. Tri-states outputs when low. Internal pull-up resistor.

Key: CI = clock input, I = input, O = output, P = power supply connection

External Components

A minimum number of external components are required for proper operation. A decoupling capacitor of 0.01 μ F should be connected between VDD on pin 7 and GND on pin 6, and a 33 Ω terminating resistor may be used on each clock output if the trace is longer than 1 inch.

**Electrical Specifications**

Parameter	Conditions	Minimum	Typical	Maximum	Units
ABSOLUTE MAXIMUM RATINGS (note 1)					
Supply voltage, VDD	Referenced to GND			7	V
Inputs and Clock Outputs	Referenced to GND	-0.5		VDD+0.5	V
Ambient Operating Temperature		0		70	°C
Soldering Temperature	Max of 20 seconds			260	°C
Storage temperature		-65		150	°C
DC CHARACTERISTICS					
Operating Voltage, VDD		3		5.5	V
Input High Voltage, VIH, IN	Clock input	VDD/2 + 1	VDD/2		V
Input Low Voltage, VIL, In	Clock input		VDD/2	VDD/2 - 1	V
Input High Voltage, VIH, OE		2			V
Input Low Voltage, VIL, OE				0.8	V
Output High Voltage, VOH, 5V	IOH=-25mA	2.4			V
Output Low Voltage, VOL, 5V	IOL=25mA			0.4	V
Output High Voltage, VOH, CMOS level	IOH=-8mA	VDD-0.4			V
Operating Supply Current, IDD, 3.3V	No load, 135 MHz		18		mA
Short Circuit Current, 3.3 V	Each output		±50		mA
Internal pull-up resistor	All inputs		200		k
AC CHARACTERISTICS					
Input Frequency		0		160	MHz
Output Frequency, 3.3 V	15 pF load. Note 3.			160	MHz
Output Frequency, 5 V	15 pF load. Note 3.			135	MHz
Output Clock Rise Time	0.8 to 2.0V			1.5	ns
Output Clock Fall Time	2.0 to 0.8V			1.5	ns
Propagation Delay	At 3.3 V	2	4	8	ns
	At 5.0 V	1.5	3	6	ns
Output to output skew	Rising edges at VDD/2			250	ps

- Notes:
1. Stresses beyond those listed under Absolute Maximum Ratings could cause permanent damage to the device. Prolonged exposure to levels above the operating limits but below the Absolute Maximums may affect device reliability.
 2. Duty cycle on outputs will match incoming clock duty cycle. Consult ICS for tight duty cycle clock generators.
 3. With external series resistor of 33 Ω positioned close to each output pin.



Package Outline and Package Dimensions

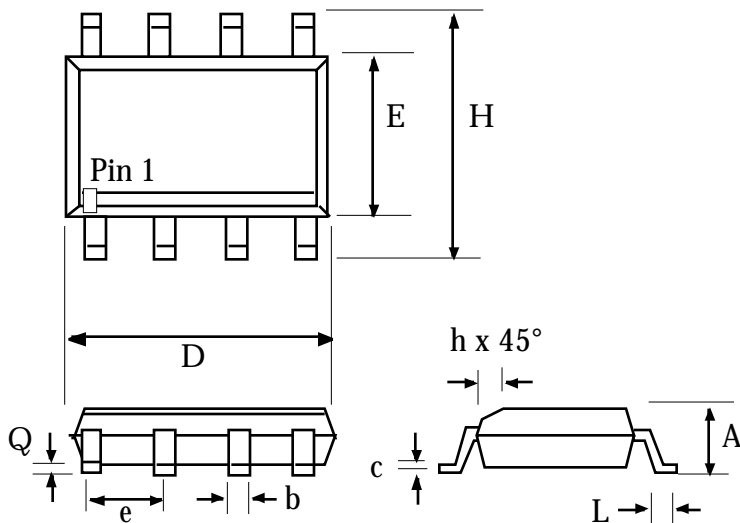

8 pin SOIC

Symbol	Inches		Millimeters	
	Min	Max	Min	Max
A	0.055	0.068	1.397	1.7272
b	0.013	0.019	0.330	0.483
D	0.185	0.200	4.699	5.080
E	0.150	0.160	3.810	4.064
H	0.225	0.245	5.715	6.223
e	.050 BSC		1.27 BSC	
h		0.015		0.381
L	0.016	0.035	0.406	0.889
Q	0.004	0.01	0.102	0.254

Ordering Information

Part/Order Number	Marking	Package	Temperature
ICS551M	ICS551M	8 pin SOIC	0 to 70 °C
ICS551MT	ICS551M	8 pin SOIC on tape and reel	0 to 70 °C

While the information presented herein has been checked for both accuracy and reliability, Integrated Circuit Systems (ICS) assumes no responsibility for either its use or for the infringement of any patents or other rights of third parties, which would result from its use. No other circuits, patents, or licenses are implied. This product is intended for use in normal commercial applications. Any other applications such as those requiring extended temperature range, high reliability, or other extraordinary environmental requirements are not recommended without additional processing by ICS. ICS reserves the right to change any circuitry or specifications without notice. ICS does not authorize or warrant any ICS product for use in life support devices or critical medical instruments.

ClockBlocks is a trademark of ICS



LittleDiode supplies new, hard to find or obsolete electronic components and semiconductors all over the world.

With over two million different components listed you are sure to find the part you need.

Feel free to visit us today at our online store:

LittleDiode.com

Looking forward to providing you with the best possible service.