



Pentium/Pro™ System and Cyrix™ Clock Chip

General Description

The ICS9147-12 is a Clock Synthesizer chip for Pentium and PentiumPro plus Cyrix CPU based Desktop/Notebook systems that will provide all necessary clock timing.

Features include four CPU, seven PCI and eight SDRAM clocks. Three reference outputs are available equal to the crystal frequency, plus the IOAPIC output powered by VDDL. Additionally, the device meets the Pentium power-up stabilization, which requires that CPU and PCI clocks be stable within 2ms after power-up.

High drive PCICLK and SDRAM outputs typically provide greater than 1V/ns slew rate into 30 pF loads. CPUCLK outputs typically provide better than 1V/ns slew rate into 20 pF loads while maintaining 50±5% duty cycle. The REF clock outputs typically provide better than 0.5V/ns slew rates.

The ICS9147-12 accepts a 14.318MHz reference crystal or clock as its input and runs on a 3.3V supply.

Features

- Generates system clocks for CPU, IOAPIC, SDRAM, PCI, plus 14.318 MHz REF(0:2), USB, Plus Super I/O
- Supports single or dual processor systems
- Supports Intel 60, 66.8MHz, Cyrix 55, 75MHz plus 83.3 and 68MHz (Turbo of 66.6) speeds.
- Synchronous clocks skew matched to 250ps window on CPU, SDRAM and 500ps window on PCI clocks
- CPU clocks to PCI clocks skew 1-4ns (CPU early)
- Two fixed outputs, 48MHz and 24 MHz
- Separate 2.5V and 3.3V supply pins
 - 2.5V or 3.3V output: CPU, IOAPIC
 - 3.3V outputs: SDRAM, PCI, REF, 48/24 MHz
- No power supply sequence requirements
- 48 pin 300 mil SSOP

Block Diagram

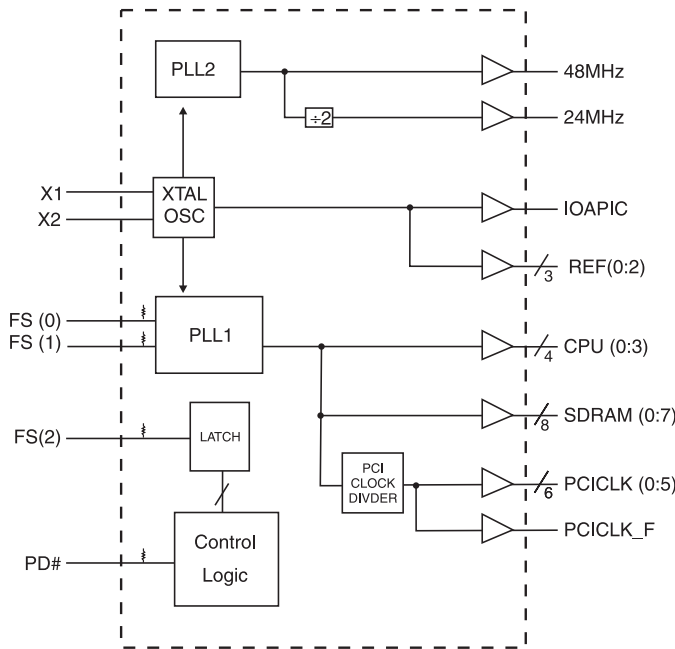

Pin Configuration

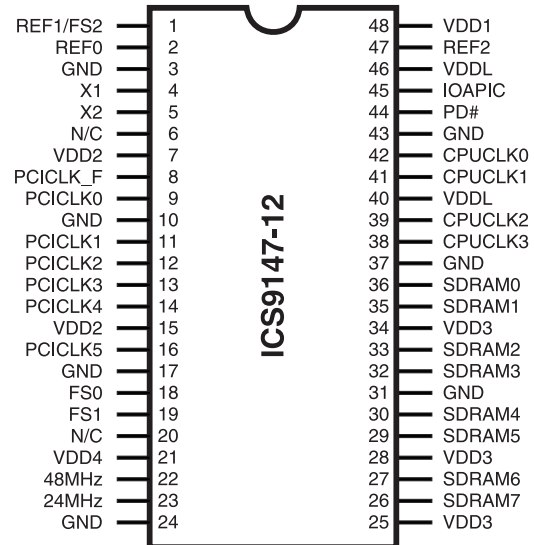

48-Pin SSOP

Power Groups

- VDD1 = REF (0:2), X1, X2
- VDD2 = PCICLK_F, PCICLK (0:5)
- VDD3 = SDRAM (0:7),
- VDD4 = 48MHz, 24MHz
- VDDL = IOAPIC, CPUCLK (0:3)



Pin Descriptions

PIN NUMBER	PIN NAME	TYPE	DESCRIPTION
1	FS2	IN	Latched input for frequency select ² ¹
	REF1	OUT	Reference clock output
2	REF0	OUT	Reference clock output
3, 10, 17, 24, 31, 31, 37, 43	GND	PWR	Ground (common)
4	X1	IN	Crystal or reference input, nominally 14.318 MHz. Includes internal load cap to GND and feedback resistor from X2.
5	X2	OUT	Crystal output, includes internal load cap to GND.
6, 20,	N/C	-	Pins are not internally connected
7, 15	VDD2	PWR	Supply for PCICLK_F, and PCICLK (0:5)
8	PCICLK_F	OUT	Free running PCI clock
9, 11, 12, 13, 14, 16	PCICLK (0:5)	OUT	PCI clocks
18	FS0	IN	Frequency select 0 input ¹
19	FS1	IN	Frequency select 1 input ¹
21	VDD4	PWR	Supply for 48MHz and 24MHz clocks
22	48MHz	OUT	48MHz driver output for USB clock
23	24MHz	OUT	24MHz driver output for Super I/O clock
25, 28,34	VDD3	PWR	Supply for SDRAM (0:7),
26, 27, 29, 30, 32, 33, 35, 36	SDRAM (0:7)	OUT	SDRAMs clock at CPU speed
38, 39, 41, 42	CPUCLK (0:3)	OUT	CPUCLK clock output, powered by VDDL
40, 46	VDDL	PWR	Supply for CPUCLK (0:3) & IOAPIC
44	PD#	IN	Power down stops all clocks low and disables oscillator and internal VCO's. ²
45	IOAPIC	OUT	IOAPIC clock output, powered by VDDL at crystal frequency
47	REF2	OUT	Reference clock output.
48	VDD1	PWR	Supply for REF (0:2), X1, X2

Note 1: Internal pull-up resistor of nomimally 100K to 120K at 3.3V on indicated inputs.

Note 2: The PD# input pin has a protection diode clamp to the VDDL power supply. If VDDL is not connected to VDD, (ie VDDL=2.5V, VDD=3.3V) then this input must have a series resistor if the logic high is connected to VDD. This input series resistor provides current limit for the clamp diode. For a pullup to VDD it should be 1Kohm or more from the PD# pin to VDD. If the PD# pin is being driven by logic powered by 3.3V, then a 100Ω series resistor will be sufficient.



Functionality

$V_{DD} = 3.3V \pm 5\%$, $V_{DDL} = 2.5V \pm 5\%$ or $3.3V \pm 5\%$, $T_A = 0$ to $70^\circ C$
Crystal (X1, X2) = 14.31818 MHz

FS2	FS1	FS0	CPUCLK, SDRAM (MHz)	PCICLK (MHz)
0	0	0	83.3	1/2 CPU
0	0	1	75	30
0	1	0	83.3	33.3
0	1	1	68.5	1/2 CPU
1	0	0	55	1/2 CPU
1	0	1	75	1/2 CPU
1	1	0	60	1/2 CPU
1	1	1	66.8	1/2 CPU

Power Management Functionality

PD#	CPUCLK Outputs	PCICLK(0:5) Outputs	PCICLK_F, REF, 24/48MHz and SDRAM	Crystal OSC	VCO
0	Stopped Low	Stopped Low	Stopped Low	Off	Off
1	Running	Running	Running	Running	Running



Technical Pin Function Descriptions

VDD(1,2,3,4)

This is the power supply to the internal core logic of the device as well as the clock output buffers for REF(0:2), PCICLK, 48/24MHz and SDRAM(0:7).

This supply operates at 3.3 volts. Clocks from the listed buffer that it supplies will have a voltage swing from Ground to this level. For the actual guaranteed high and low voltage levels for the Clocks, please consult the DC parameter table in this data sheet.

VDDL

This is the power supply for the CPUCLK and IOAPIC output buffers. The voltage level for these outputs may be 2.5 or 3.3 volts. Clocks from the buffers that each supplies will have a voltage swing from Ground to this level. For the actual guaranteed high and low voltage levels of these Clocks, please consult the DC parameter table in this Data Sheet.

GND

This is the power supply ground (common or negative) return pin for the internal core logic and all the output buffers.

X1

This input pin serves one of two functions. When the device is used with a Crystal, X1 acts as the input pin for the reference signal that comes from the discrete crystal. When the device is driven by an external clock signal, X1 is the device input pin for that reference clock. This pin also implements an internal Crystal loading capacitor that is connected to ground. See the data tables for the value of this capacitor. Also includes feedback resistor from X2.

X2

This Output pin is used only when the device uses a Crystal as the reference frequency source. In this mode of operation, X2 is an output signal that drives (or excites) the discrete Crystal. The X2 pin will also implement an internal Crystal loading capacitor that is connected to ground. See the Data Sheet for the value of this capacitor.

CPUCLK(0:3)

These Output pins are the Clock Outputs that drive processor and other CPU related circuitry that requires clocks which are in tight skew tolerance with the CPU clock. The voltage swing of these Clocks is controlled by the Voltage level applied to the VDDL2 pin of the device. See the Functionality Table for a list of the specific frequencies that are available for these Clocks and the selection codes to produce them.

SDRAM(0:7)

These Output Clocks are used to drive Dynamic RAM's and are low skew copies of the CPU Clocks. The voltage swing of the SDRAM's output is controlled by the supply voltage that is applied to VDD3 of the device, operating at 3.3 volts.

48MHz

This is a fixed frequency Clock output at 48MHz that is typically used to drive USB devices.

24MHz

This pin is a fixed frequency clock output typically used to drive Super I/O devices.

IOAPIC

This Output is a fixed frequency Output Clock that runs at the Reference Input (typically 14.31818MHz). Its voltage level swing is controlled by VDDL and may operate at 2.5 or 3.3volts.

REF(0:2)

The REF Outputs are fixed frequency Clocks that run at the same frequency as the Input Reference Clock X1 or the Crystal (typically 14.31818MHz) attached across X1 and X2.

PCICLK_F

This Output is equivalent to PCICLK(0:5) and is FREE RUNNING

PCICLK(0:5)

These Output Clocks generate all the PCI timing requirements for a Pentium/Pro based system. They conform to the current PCI specification. They run at 1/2 CPU frequency, or CPU/2.5; see frequency table.

FS0,1,2

These Input pins control the frequency of the Clocks at the CPU, PCICLK and SDRAM output pins. See frequency table. The level of FS2 is latched at power-on, defined by a series resistor (typically 10K ohm) to VDD or GND.

PD#

This input pin stops all clocks in the low state and powers down the oscillator and VCOs.



Absolute Maximum Ratings

Supply Voltage	7.0V
Logic Inputs	GND–0.5 V to V _{DD} +0.5 V
Ambient Operating Temperature	0°C to +70°C
Storage Temperature	–65°C to +150°C

Stresses above those listed under *Absolute Maximum Ratings* may cause permanent damage to the device. These ratings are stress specifications only and functional operation of the device at these or any other conditions above those listed in the operational sections of the specifications is not implied. Exposure to absolute maximum rating conditions for extended periods may affect product reliability.

Electrical Characteristics at 3.3V

V_{DD} = 3.0 – 3.7V, T_A = 0 – 70°C unless otherwise stated

DC Characteristics						
PARAMETER	SYMBOL	TEST CONDITIONS	MIN	TYP	MAX	UNITS
Input Low Voltage	VIL	Latched inputs and Fulltime inputs	-	-	0.2VDD	V
Input High Voltage	VIH	Latched inputs and Fulltime inputs	0.7VDD	-	-	V
Input Low Current	IIL	VIN = 0V (Fulltime inputs)	-28.0	-10.5	-	µA
Input High Current	IIH	VIN=VDD (Fulltime inputs)	-5.0	-	5.0	µA
Output Low Current	IOL1a	VOL = 0.8V; CPU, SDRAM, 48MHz; VDDL = 3.3V	19.0	30.0	-	mA
	IOL1b	VOL = 0.8V; CPU; VDDL = 2.5V	19.0	30.0	-	mA
Output High Current	IOH1a	VOH = 2.0V; CPU, SDRAM, 48MHz; VDDL = 3.3V	-	-26.0	-16.0	mA
	IOH1b	VOH = 2.0V; CPU; VDDL = 2.5V	-	-12.5	-9.5	mA
Output Low Current	IOL2a	VOL = 0.8V; 24, PCI, REF, IOAPIC; VDDL = 3.3V	16.0	25.0	-	mA
	IOL2b	VOL = 0.8V; IOAPIC; VDDL = 2.5V	16.0	25.0	-	mA
Output High Current	IOH2a	VOH = 2.0V for IOAPIC, PCI, REF, 24MHz at VDDL = 3.3V	-	-40.0	-14.0	mA
	IOH2b	VOH = 2.0V; IOAPIC; VDDL = 2.5V	-	-13.0	-4.0	mA
Output Low Voltage	VOL1a	IOL = 10mA; CPU, SDRAM, 48MHz; VDDL = 3.3V	-	0.3	0.4	V
	VOL1b	IOL = 10mA; CPU; VDDL = 2.5V	-	0.3	0.4	V
Output High Voltage	VOH1a	IOH = -10mA; CPU, SDRAM, 48MHz; VDDL = 3.3V	2.4	2.8	-	V
	VOH1b	IOH = -10mA; CPU; VDDL = 2.5V	1.95	2.1	-	V
Output Low Voltage	VOL2a	IOL = 10mA; for IOAPIC, PCI, REF, 24MHz at VDDL= 3.3V	-	0.3	0.4	V
	VOL2b	IOL = 10mA; PCI, REF, IOAPIC; VDDL = 2.5V	-	0.3	0.4	V
Output High Voltage	VOH2a	IOH = -10mA; for IOAPIC, PCI, REF, 24MHz at VDDL = 3.3V	2.4	2.8	-	V
	VOH2b	IOH = -10mA; IOAPIC; VDDL = 2.5V	1.6	2.1	-	V
Supply Current	IDD	@66.6 MHz; all outputs unloaded	-	120	180	mA
Supply Current	IDDPD	Power Down	-	300	500	µA

Note 1: Parameter is guaranteed by design and characterization. Not 100% tested in production.



Electrical Characteristics at 3.3V

V_{DD} = 3.0 – 3.7V, T_A = 0 – 70° C unless otherwise stated

AC Characteristics						
PARAMETER	SYMBOL	TEST CONDITIONS	MIN	TYP	MAX	UNITS
Rise Time ¹	T _{rla}	20pF load, 0.8 to 2.0V CPU, 48MHz; VDD = 3.3V	-	0.9	1.5	ns
Rise Time ¹	T _{rlb}	20pF load, 0.8 to 2.0V CPU; VDDL @ 2.5V	-	1.5	2.0	ns
Fall Time ^{1,3}	T _{fl}	20pF load, 2.0 to 0.8V CPU, 48MHz;	-	0.8	1.4	ns
Rise Time ¹	T _{r2}	30pF load SDRAM 0.8 to 2.0V	-	1.0	1.6	ns
Fall Time ¹	T _{f2}	30pF load SDRAM 2.0 to 0.8V	-	0.9	1.5	ns
Rise Time ¹	T _{r3}	30pF load PCI 0.8 to 2.0V	-	1.2	2.0	ns
Fall Time ¹	T _{f3}	30pF load PCI 2.0 to 0.8V	-	1.1	1.9	ns
Rise Time ^{1,3}	T _{r4}	20pF load, 0.8 to 2.0V 24MHz, REF (1:2) & IOAPIC	-	0.83	1.4	ns
Rise Time ¹	T _{r4a}	45pF load, 0.8 to 2.0V, IOAPIC with VDDL = 2.5V	-	2.2	2.6	ns
Fall Time ^{1,3}	T _{f4}	20pF load, 2.0 to 0.8V 24MHz, REF (1:2) & IOAPIC	-	0.81	1.3	ns
Rise Time ¹	T _{r5}	Load = 45pF 0.8 to 2.0V REF0 VDD = 3.3V		1.6	2.0	ns
Fall Time ¹	T _{f5}	Load = 45pF 2.0 to 0.8V, REF0 VDD = 3.3V		1.6	2.0	ns
Duty Cycle ¹	D _t	20pF load @ VOUT=1.4V	45	50	55	%
Jitter, Cycle to Cycle ¹	T _{jc-c}	CPU, VDDL = 3.0 to 3.7V		250	300	ps
Jitter, One Sigma ^{1, 2}	T _{j1s1}	CPU; Load=20pF, SDRAM & BUS Clocks Load = 30pF	-	50	150	ps
Jitter, Absolute ^{1, 2}	T _{jab1}	CPU; Load=20pF, SDRAM & PCI Clocks Load = 30pF	-250	-	250	ps
Jitter Absolute ¹	T _{jab1a}	PCI; Load=30pF	-500	-	500	ps
Jitter, One Sigma ¹	T _{j1s2}	REF (1:2), 48/24MHz Load=20pF, REF0 C _L = 45pF	-	1	3	%
Jitter, Absolute ¹	T _{jab2}	REF (1:2), 48/24MHz Load=20pF, REF0 C _L = 45pF	-5	2	5	%
Input Frequency ¹	F _i		12.0	14.318	16.0	MHz
Logic Input Capacitance ¹	C _{IN}	Logic input pins	-	5	-	pF
Crystal Oscillator Capacitance ¹	C _{INX}	X1, X2 pins	-	18	-	pF
Power-on Time ¹	t _{on}	From VDD=1.6V to 1st crossing of 66.6 MHz VDD supply ramp < 40ms	-	2.5	4.5	ms
Clock Skew ¹	T _{sk1}	CPU to CPU; Load=20pF; @1.4V (Same VDD)	-	150	250	ps
Clock Skew ¹	T _{sk2}	SDRAM to SDRAM; Load=30pF @ 1.4V	-	150	250	ps
Clock Skew ¹	T _{sk2}	PCI to PCI; Load=20pF; @1.4V	-	300	500	ps
Clock Skew ^{1,2}	T _{sk3}	CPU(20pF) to PCI (30pF); @1.4V (CPU is early)	1	2.6	4	ns
Clock Skew ¹	T _{sk4}	SDRAM (30pF @3.3V) to CPU (20pF @2.5V) (2.5V CPU is late)		250	400	ps

Note 1: Parameter is guaranteed by design and characterization. Not 100% tested in production.

Note 2: Includes VDDL = 2.5V

Note 3: VDD3 = 3.3V



Shared Pin Operation - Input/Output Pins

Pins 1 and 2 on the ICS9147-12 serves as dual signal functions to the device. During initial power-up, it acts as an input pin. The logic level (voltage) that is present on this pin at this time is read and stored into a 4-bit internal data latch. At the end of Power-On reset, (see AC characteristics for timing values), the device changes the mode of operations for this pin to an output function. In this mode the pin produces the specified buffered clocks to external loads.

To program (load) the internal configuration register for this pin, a resistor is connected to either the VDD (logic 1) power supply or the GND (logic 0) voltage potential. A 10 Kiloohm(10K) resistor is used to provide both the solid CMOS programming voltage needed during the power-up programming period and to provide an insignificant load on the output clock during the subsequent operating period.

Figs. 1 and 2 show the recommended means of implementing this function. In Fig. 1 either one of the resistors is loaded onto the board (selective stuffing) to configure the device's internal logic. Figs. 2a and b provide a single resistor loading option where either solder spot tabs or a physical jumper header may be used.

These figures illustrate the optimal PCB physical layout options. These configuration resistors are of such a large ohmic value that they do not effect the low impedance clock signals. The layouts have been optimized to provide as little impedance transition to the clock signal as possible, as it passes through the programming resistor pad(s).

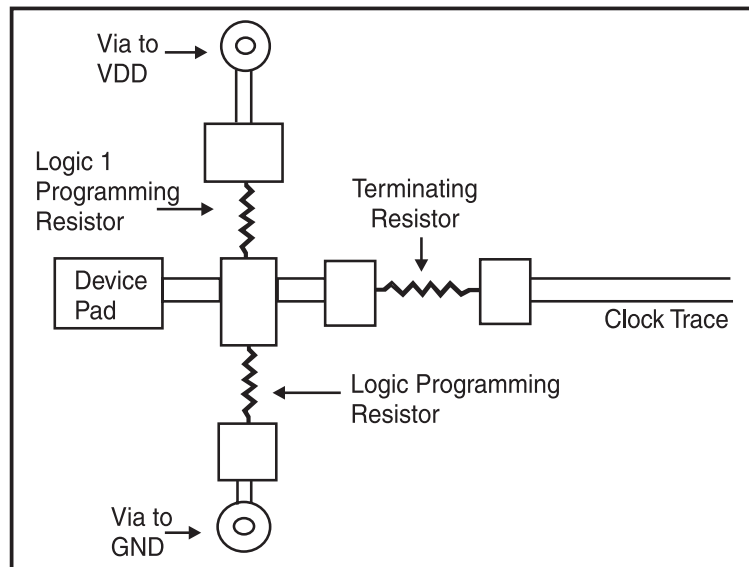

Fig. 1

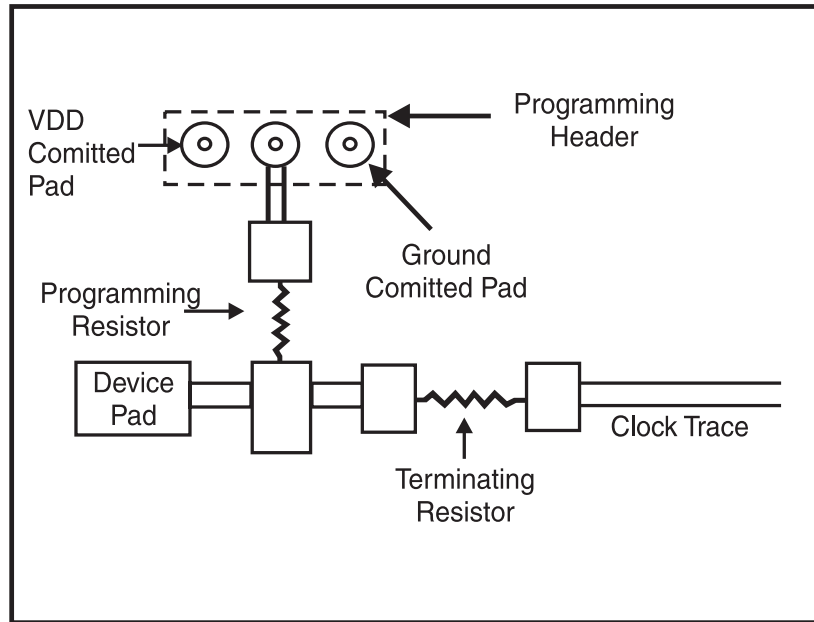

Fig. 2a

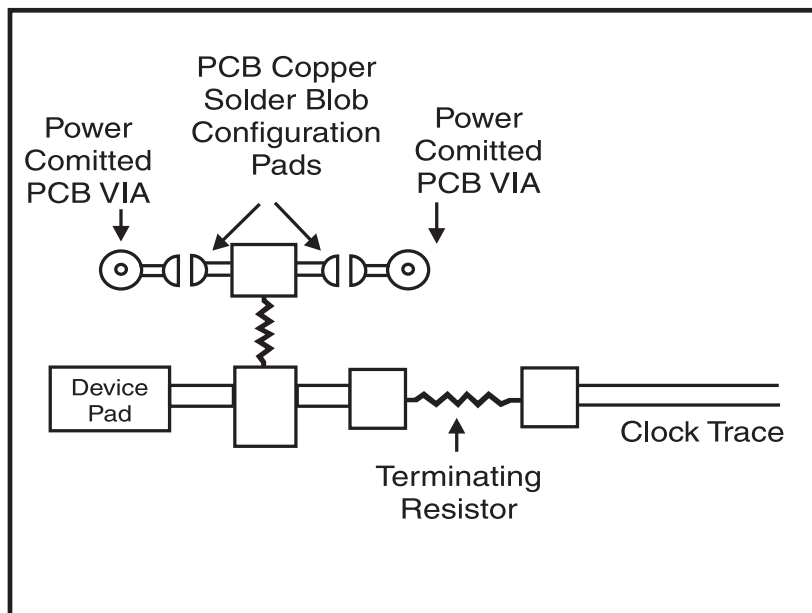
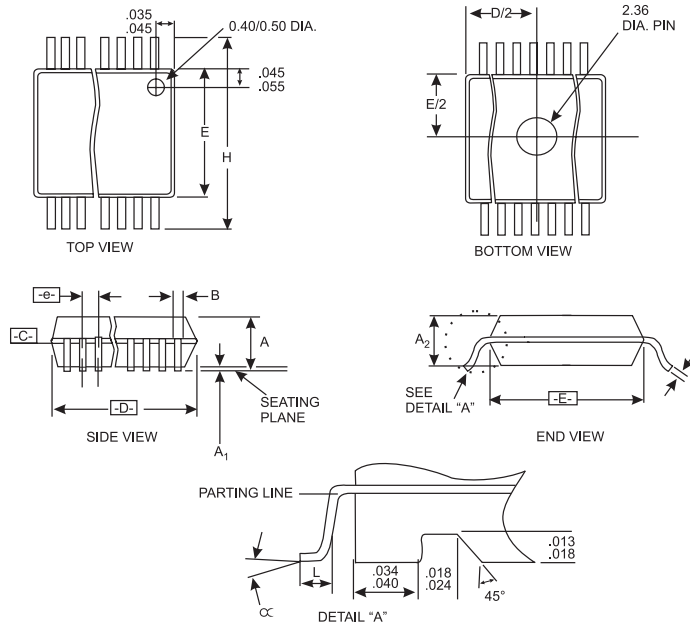

Fig. 2b



SSOP Package

SYMBOL	COMMON DIMENSIONS			VARIATIONS	D			N
	MIN.	NOM.	MAX.		MIN.	NOM.	MAX.	
A	.095	.101	.110	AC	.620	.625	.630	48
A1	.008	.012	.016	AD	.720	.725	.730	56
A2	.088	.090	.092					
B	.008	.010	.0135					
C	.005	.006	.0085					
D	See Variations							
E	.292	.296	.299					
e	0.025 BSC							
H	.400	.406	.410					
h	.010	.013	.016					
L	.024	.032	.040					
N	See Variations							
∞	0°	5°	8°					
X	.085	.093	.100					

This table in inches

Ordering Information

ICS9147F-12

Example:

ICS XXXX F - PPP

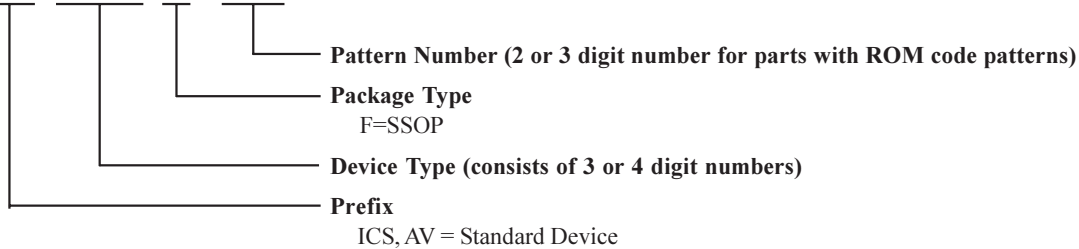



LittleDiode supplies new, hard to find or obsolete electronic components and semiconductors all over the world.

With over two million different components listed you are sure to find the part you need.

Feel free to visit us today at our online store:

LittleDiode.com

Looking forward to providing you with the best possible service.