



# Frequency Generator for Pentium™/OPTi VIPER Systems

## General Description

The ICS9159-05 is a low cost frequency generator designed specifically for Pentium/Pentium Pro systems. The integrated buffer minimizes skew and provides the early CPU clock required by some chipsets such as the OPTi VIPER. A 14.318 MHz XTAL oscillator provides the reference clock to generate standard Pentium frequencies. The CPU clock makes gradual frequency transitions without violating the PLL timing of internal micro-processor clock multipliers.

The synchronous bus frequencies are selectable as CPU for local bus or CPU/2 for PCI bus support. Green PC systems are supported through power-down, doze, and glitch-free stop clock modes.

## Features

- Four CPU clocks operate up to 66.6 MHz at 3.3V with glitch-free start and stop plus smooth transitions
- 3-6ns early CPU clock supports OPTi VIPER systems
- Selection of 6 frequencies, tristate, or power-down
- Six BUS clocks support local PCI bus operation
- Skew window between synchronous outputs
- Integrated buffer outputs drive up to 30pF loads
- 3.0V - 3.7V supply range
- 28-pin DIP or 28-pin 300-mil SOIC package

## Applications

- Ideal for green Pentium/Pentium Pro and 486 PCI systems such as Pentium, PowerPC™ etc.

## Block Diagram

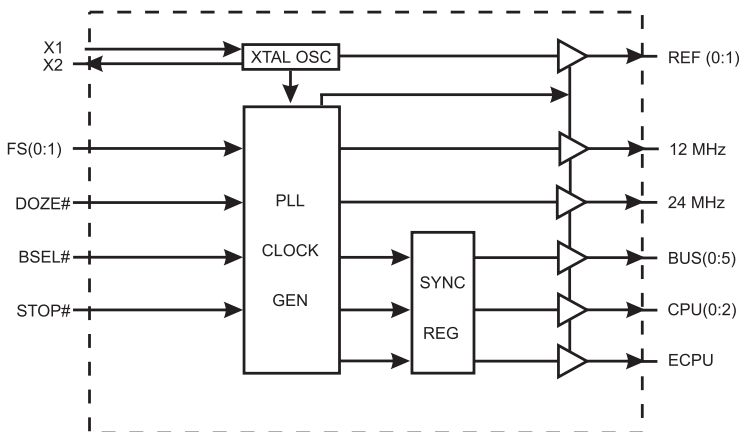

## Pin Configuration

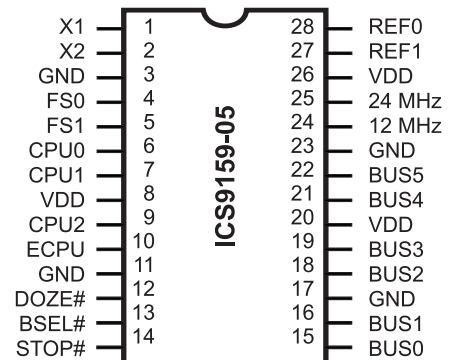

## 28-Pin 300-mil SOIC

Pentium is a trademark of Intel Corporation.  
PowerPC is a trademark of Motorola Corporation.



## Functionality

Assuming 14.318 MHz input, all frequencies in MHz. 14 MHz=14.318 MHz

| STOP# | BSEL# | DOZE# | FS0    | FS1    | CPU (0:2) (MHz) | ECPU (MHz) | BUS (0:5) (MHz) | FIXED (MHz) |
|-------|-------|-------|--------|--------|-----------------|------------|-----------------|-------------|
| 1     | 0     | 1     | X      | X      | F               | F          | F               | 24, 12, 14  |
| 1     | 1     | 1     | X      | X      | F               | F          | F               | 24, 12, 14  |
| 1     | 0     | 0     | X      | X      | F/2             | F/2        | F/4             | 24, 12, 14  |
| 1     | 1     | 0     | X      | X      | F/2             | F/2        | F/2             | 24, 12, 14  |
| 0     | 1     | 1     | Select | Select | Stop            | Run        | Run             | 24, 12, 14  |
| 0     | 0     | 1     | X      | X      | Stop            | Stop       | Stop            | 24, 12, 14  |
| 0     | 0     | 0     | X      | X      | Low             | Low        | Low             | L, L, 14    |
| 0     | 1     | 0     | X      | X      | Tristate        | Tristate   | Tristate        | Tristate    |

Notes:

- Where F is Frequency selected by FS (0:1)
- F value is 66.6, 60, 50 or 33.3.

| STOP#          | BSEL#          | DOZE#          | FS0                 | FS1                 | CPU (0:2) (MHz) | ECPU (MHz)     | BUS (0:5) (MHz) | FIXED (MHz) |
|----------------|----------------|----------------|---------------------|---------------------|-----------------|----------------|-----------------|-------------|
| 1              | 0              | 1              | 0                   | 0                   | 66.6            | 66.6           | 33.3            | 24, 12, 14  |
| 1              | 0              | 1              | 0                   | 1                   | 60              | 60             | 30              | 24, 12, 14  |
| 1              | 0              | 1              | 1                   | 0                   | 50              | 50             | 25              | 24, 12, 14  |
| 1              | 0              | 1              | 1                   | 1                   | 33.3            | 33.3           | 16.7            | 24, 12, 14  |
| 1              | 1              | 1              | 0                   | 0                   | 66.6            | 66.6           | 66.6            | 24, 12, 14  |
| 1              | 1              | 1              | 0                   | 1                   | 60              | 60             | 60              | 24, 12, 14  |
| 1              | 1              | 1              | 1                   | 0                   | 50              | 50             | 50              | 24, 12, 14  |
| 1              | 1              | 1              | 1                   | 1                   | 33.3            | 33.3           | 33.3            | 24, 12, 14  |
| 1              | 0              | 0              | 0                   | 0                   | 33.3            | 33.3           | 16.7            | 24, 12, 14  |
| 1              | 0              | 0              | 0                   | 1                   | 30              | 30             | 15              | 24, 12, 14  |
| 1              | 0              | 0              | 1                   | 0                   | 25              | 25             | 12.5            | 24, 12, 14  |
| 1              | 0              | 0              | 1                   | 1                   | 16.7            | 16.7           | 8.3             | 24, 12, 14  |
| 1              | 1              | 0              | 0                   | 0                   | 33.3            | 33.3           | 33.3            | 24, 12, 14  |
| 1              | 1              | 0              | 0                   | 1                   | 30              | 30             | 30              | 24, 12, 14  |
| 1              | 1              | 0              | 1                   | 0                   | 25              | 25             | 25              | 24, 12, 14  |
| 1              | 1              | 0              | 1                   | 1                   | 16.7            | 16.7           | 16.7            | 24, 12, 14  |
| 1              | 1              | 1              | Select <sup>2</sup> | Select <sup>2</sup> | F <sup>3</sup>  | F <sup>3</sup> | F <sup>3</sup>  | 24, 12, 14  |
| 1              | 1              | 0              | Select <sup>2</sup> | Select <sup>2</sup> | F/2             | F/2            | F/2             | 24, 12, 14  |
| 0              | 1              | 1              | Select <sup>2</sup> | Select <sup>2</sup> | Stop            | Run            | Run             | 24, 12, 14  |
| 0              | 0              | 1              | X                   | X                   | Stop            | Stop           | Stop            | L, L, 14    |
| 0 <sup>1</sup> | 0 <sup>1</sup> | 0 <sup>1</sup> | X                   | X                   | Low             | Low            | Low             | L, L, 14    |
| 0              | 1              | 0              | X                   | X                   | Tristate        | Tristate       | Tristate        | Tristate    |

Notes:

- 000 mode powers-down the PLL sections and forces the outputs low. To ensure glitch-free start and stop of the CPU and BUS clocks, enter 000 from 001 and exit 000 through 001.
- Select is FS0, Fs1 = 00, 01, 10, 11.
- F is the value of CPU, ECPU & BUS. F value is 66.6, 60, 50 or 33.3 as selected by FS(0:1).



## Pin Descriptions

| PIN NUMBER             | PIN NAME           | TYPE | DESCRIPTION   |
|------------------------|--------------------|------|---|
| 8, 20, 26              | VDD                | PWR  | Power for logic, CPU and fixed frequency output buffers.  |
| 1                      | X1                 | IN   | XTAL or external reference frequency input. This input includes XTAL load capacitance and feedback bias for a 4-20 MHz XTAL, normally 14.318 MHz. |
| 2                      | X2                 | OUT  | XTAL output which includes XTAL load capacitance.   |
| 3, 11, 23, 17          | GND                | PWR  | Ground for logic, CPU and fixed frequency output buffers.   |
| 6, 7, 9                | CPU(0:2)           | OUT  | Processor clock outputs which are a multiple of the input reference frequency as shown in the table.  |
| 4, 5                   | FS(0:1)            | IN   | Frequency multiplier select pins. See table below. These inputs have internal pull-up devices.  |
| 10                     | ECPU               | OUT  | Early CPU clock. Transition precedes CPU clocks.  |
| 15, 16, 18, 19, 21, 22 | BUS(0:5)           | OUT  | Bus clock outputs are fixed at 1/2 the PCLK frequency.  |
| 12                     | DOZE# <sup>1</sup> | IN   | Doze mode control. Reduces CPU and BUS clock frequencies by 1/2 when low.   |
| 13                     | BSEL# <sup>1</sup> | IN   | BUS select for BSEL = 0, BUS = CPU/2<br>for BSEL = 1, BUS = CPU   |
| 14                     | STOP# <sup>1</sup> |      | Stop Clock. Stops all CPU clock outputs and forces them to a logic low level synchronously with their next low level transition.                  |
| 24                     | KEYBD              | OUT  | 12 MHz fixed clock (with 14.318 MHz input).   |
| 25                     | DISK               | OUT  | 24 MHz fixed clock (with 14.318 MHz input).   |
| 27, 28                 | REF (0:1)          | OUT  | REF is a buffered copy of the crystal oscillator or reference input clock, nominally 14.31818 MHz.  |

Note:

1. Internally pulled-up



## Absolute Maximum Ratings

|                                     |                                |
|-------------------------------------|--------------------------------|
| Supply Voltage .....                | 7.0 V                          |
| Logic Inputs .....                  | GND -0.5 V to $V_{DD} + 0.5$ V |
| Ambient Operating Temperature ..... | 0°C to +70°C                   |
| Storage Temperature .....           | -65°C to +150°C                |

Stresses above those listed under *Absolute Maximum Ratings* may cause permanent damage to the device. These ratings are stress specifications only and functional operation of the device at these or any other conditions above those listed in the operational sections of the specifications is not implied. Exposure to absolute maximum rating conditions for extended periods may affect product reliability.

## Electrical Characteristics at 3.3V

$V_{DD} = 3.0 - 3.7$  V,  $T_A = 0 - 70^\circ$  C unless otherwise stated

| DC Characteristics               |            |                                  |             |       |             |         |
|----------------------------------|------------|----------------------------------|-------------|-------|-------------|---------|
| PARAMETER                        | SYMBOL     | TEST CONDITIONS                  | MIN         | TYP   | MAX         | UNITS   |
| Input Low Voltage                | $V_{IL}$   |                                  | -           | -     | $0.2V_{DD}$ | V       |
| Input High Voltage               | $V_{IH}$   |                                  | $0.7V_{DD}$ | -     | -           | V       |
| Input Low Current                | $I_{IL}$   | $V_{IN}=0V$                      | -25.0       | -5    | -           | $\mu A$ |
| Input High Current               | $I_{IH}$   | $V_{IN}=V_{DD}$                  | -5.0        | -     | 5.0         | $\mu A$ |
| Output Low Current <sup>1</sup>  | $I_{OL}$   | $V_{OL}=0.8V$ ; for CPU & BUS    | 30.0        | 47.0  | -           | mA      |
| Output High Current <sup>1</sup> | $I_{OH}$   | $V_{OL}=2.0V$ ; for CPU & BUS    | -           | -66.0 | -42.0       | mA      |
| Output Low Current <sup>1</sup>  | $I_{OL}$   | $V_{OL}=0.8V$ ; for fixed CLKs   | 25.0        | 38.0  | -           | mA      |
| Output High Current <sup>1</sup> | $I_{OH}$   | $V_{OL}=2.0V$ ; for fixed CLKs   | -           | -47.0 | -30.0       | mA      |
| Output Low Voltage <sup>1</sup>  | $V_{OL}$   | $I_{OL}=15mA$ ; for CPU & BUS    | -           | 0.30  | .4          | V       |
| Output High Voltage <sup>1</sup> | $V_{OH}$   | $I_{OH}=-30mA$ ; for CPU & BUS   | 2.4         | 2.8   | -           | V       |
| Output Low Voltage <sup>1</sup>  | $V_{OL}$   | $I_{OL}=12.5mA$ ; for fixed CLKs | -           | 0.30  | .4          |         |
| Output High Voltage <sup>1</sup> | $V_{OH}$   | $I_{OH}=-20mA$ ; for fixed CLKs  | 2.4         | 2.8   | -           | V       |
| Supply Current                   | $I_{DD}$   | @ 66.6 MHz; all outputs unloaded | -           | 55    | 110         | mA      |
|                                  | $I_{DDPD}$ | @ 000 mode (power-down)          |             | 8     | 20          | a       |
|                                  | $I_{DDs}$  | @ 001 mode (stop)                |             | 35    | 70          | a       |

**Note 1:** Parameter is guaranteed by design and characterization. Not 100% tested in production.



### Electrical Characteristics at 3.3V

V<sub>DD</sub> = 3.0 – 3.7 V, T<sub>A</sub> = 0 – 70° C unless otherwise stated

| AC Characteristics                          |                   |   |      |        |      |       |
|---|-------------------|---|------|--------|------|-------|
| PARAMETER                                   | SYMBOL            | TEST CONDITIONS                                     | MIN  | TYP    | MAX  | UNITS |
| Rise Time <sup>1</sup>                      | T <sub>r1</sub>   | 20pF load, 0.8 to 2.0V<br>CPU & BUS                 | -    | 0.9    | 1.5  | ns    |
| Fall Time <sup>1</sup>                      | T <sub>f1</sub>   | 20pF load, 2.0 to 0.8V<br>CPU & BUS                 | -    | 0.8    | 1.4  | ns    |
| Rise Time <sup>1</sup>                      | T <sub>r2</sub>   | 20pF load, 20% to 80%<br>CPU & BUS                  | -    | 1.5    | 2.5  | ns    |
| Fall Time <sup>1</sup>                      | T <sub>f2</sub>   | 20pF load, 80% to 20%<br>CPU & BUS                  | -    | 1.4    | 2.4  | ns    |
| Duty Cycle <sup>1</sup>                     | D <sub>t</sub>    | 20pF load @ V <sub>OUT</sub> =1.4V                  | 45   | 50     | 55   | %     |
| Jitter, One Sigma <sup>1</sup>              | T <sub>j1s1</sub> | CPU & BUS Clocks; Load=20pF,<br>R <sub>S</sub> =33Ω | -    | 40     | 150  | ps    |
| Jitter, Absolute <sup>1</sup>               | T <sub>jab1</sub> | CPU & BUS Clocks; Load=20pF,<br>R <sub>S</sub> =33Ω | -300 | -      | 300  | ps    |
| Jitter, One Sigma <sup>1</sup>              | T <sub>j1s2</sub> | Fixed CLK; Load=20pF                                | -    | 1      | 3    | %     |
| Jitter, Absolute <sup>1</sup>               | T <sub>jab2</sub> | Fixed CLK; Load=20pF                                | -    | 2      | 5    | %     |
| Input Frequency <sup>1</sup>                | F <sub>i</sub>    |   | 4.0  | 14.318 | 20.0 | MHz   |
| Logic Input Capacitance <sup>1</sup>        | C <sub>IN</sub>   | Logic input pins                                    | -    | 5      | -    | pF    |
| Crystal Oscillator Capacitance <sup>1</sup> | C <sub>INX</sub>  | X1, X2 pins   | -    | 18     | -    | pF    |
| Clock Skew Window <sup>1</sup>              | T <sub>sk1</sub>  | CPU to CPU; Load=20pF; @1.4V                        | -    | 150    | 250  | ps    |
| Clock Skew Window <sup>1</sup>              | T <sub>sk</sub>   | BUS to BUS;<br>Load=20pF @ 1.4V                     | -    | 300    | 500  | ps    |
| Clock Skew Window <sup>1</sup>              | T <sub>sk3</sub>  | ECPU to CPU;<br>Load=20pF; @1.4V                    | 3.0  | -      | 6.0  | ns    |
| Clock Skew Window <sup>1</sup>              | T <sub>SR4</sub>  | CPU to BUS;<br>Load=20pF; @1.4v                     | 0.5  | 1.0    | 3.0  | ns    |

**Note 1:** Parameter is guaranteed by design and characterization. Not 100% tested in production.



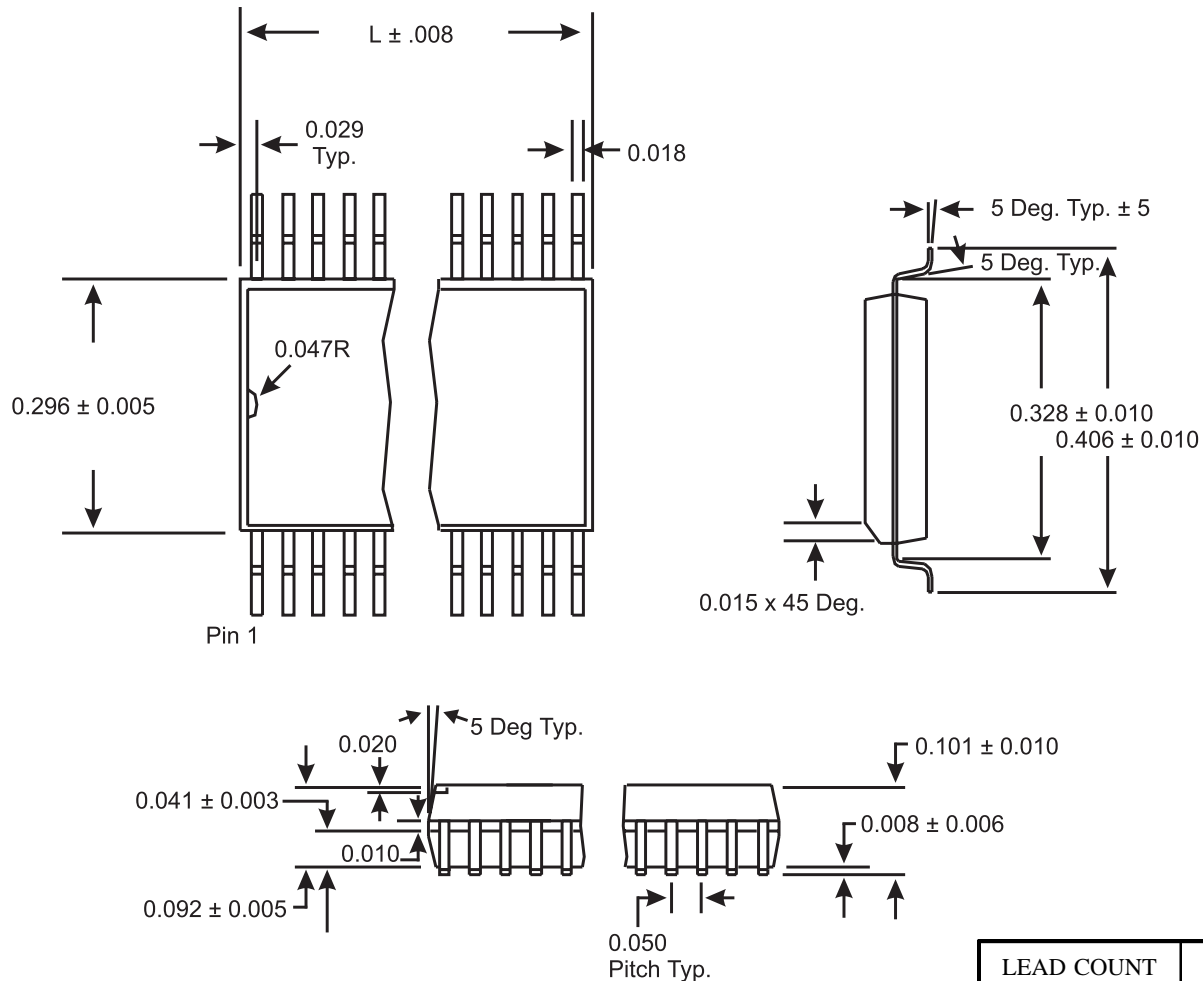

|            |       |
|------------|-------|
| LEAD COUNT | 28L   |
| DIMENSIONL | 0.704 |

**SOIC Package**

**Ordering Information**

**ICS9159M-05**

Example:

**ICS XXXX M-PPP**

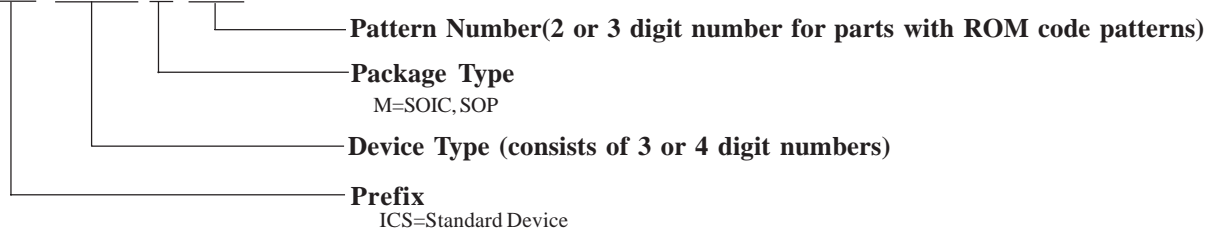



LittleDiode supplies new, hard to find or obsolete electronic components and semiconductors all over the world.

With over two million different components listed you are sure to find the part you need.

Feel free to visit us today at our online store:

[LittleDiode.com](http://LittleDiode.com)

Looking forward to providing you with the best possible service.