



HIGH-SPEED 64K x 16 BANK-SWITCHABLE DUAL-PORTED SRAM WITH EXTERNAL BANK SELECTS

IDT707288S/L

Features

- ◆ 64K x 16 Bank-Switchable Dual-Ported SRAM Architecture
 - Four independent 16K x 16 banks
 - 1 Megabit of memory on chip
- ◆ Fast asynchronous address-to-data access time: 15ns
- ◆ User-controlled input pins included for bank selects
- ◆ Independent port controls with asynchronous address & data busses
- ◆ Four 16-bit mailboxes available to each port for inter-processor communications; interrupt option
- ◆ Interrupt flags with programmable masking
- ◆ Dual Chip Enables allow for depth expansion without external logic
- ◆ \overline{UB} and \overline{LB} are available for x8 or x16 bus matching
- ◆ TTL-compatible, single 5V ($\pm 10\%$) power supply
- ◆ Available in a 100-pin Thin Quad Flatpack (14mm x 14mm)

Functional Block Diagram

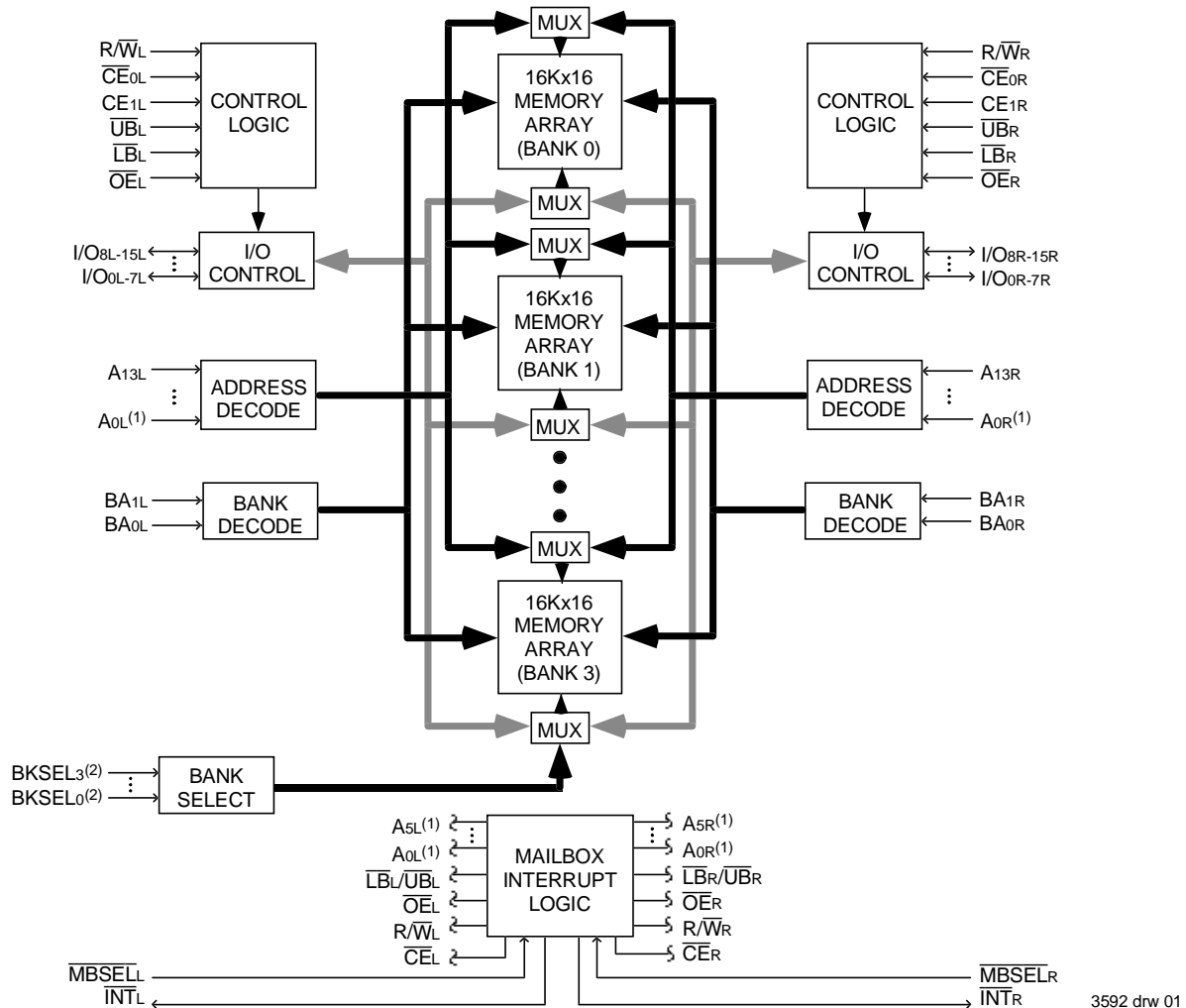

NOTES:

1. The first six address pins for each port serve dual functions. When $\overline{MBSEL} = V_{IH}$, the pins serve as memory address inputs. When $\overline{MBSEL} = V_{IL}$, the pins serve as mailbox address inputs.
2. Each bank has an input pin assigned that allows the user to toggle the assignment of that bank between the two ports. Refer to Truth Table I for more details.

MAY 2000

Description

The IDT707288 is a high-speed 64K x 16 (1M bit) Bank-Switchable Dual-Ported SRAM organized into four independent 16K x 16 banks. The device has two independent ports with separate control, address, and I/O pins for each port, allowing each port to asynchronously access any 16K x 16 memory block not already accessed by the other port. Accesses by the ports into specific banks are controlled via bank select pin inputs under the user's control. Mailboxes are provided to allow inter-processor communication. Interrupts are provided to indicate mailbox writes have occurred. An automatic power down feature controlled by the chip enables ($\overline{CE0}$ and $CE1$) permits the on-chip circuitry of each port to enter a very low standby power mode and allows fast depth expansion.

The IDT707288 offers a maximum address-to-data access time as fast as 15ns, and is packaged in a 100-pin Thin Quad Flatpack (TQFP).

Functionality

The IDT707288 is a high-speed asynchronous 64K x 16 Bank-Switchable Dual-Ported SRAM, organized in four 16K x 16 banks. The two ports are permitted independent, simultaneous access into separate banks within the shared array. There are four user-controlled Bank Select input pins, and each of these pins is associated with a specific bank within the memory array. Access to a specific bank is gained by placing the associated Bank Select pin in the appropriate state: V_{IH} assigns the bank to the left port, and V_{IL} assigns the bank to the right port (See Truth Table

IV). Once a bank is assigned to a particular port, the port has full access to read and write within that bank. Each port can be assigned as many banks within the array as needed, up to and including all four banks.

The IDT707288 provides mailboxes to allow inter-processor communication. Each port has four 16-bit mailbox registers available to which it can write and read and which the opposite port can read only. These mailboxes are external to the common SRAM array, and are accessed by setting $\overline{MBSEL} = V_{IL}$ while setting $\overline{CE} = V_{IH}$. Each mailbox has an associated interrupt: a port can generate an interrupt to the opposite port by writing to the upper byte of any one of its four 16-bit mailboxes. The interrupted port can clear the interrupt by reading the upper byte. This read will not alter the contents of the mailbox.

If desired, any source of interrupt can be independently masked via software. Two registers are provided to permit interpretation of interrupts: the Interrupt Cause Register and the Interrupt Status Register. The Interrupt Cause Register gives the user a snapshot of what has caused the interrupt to be generated - the specific mailbox written to. The information in this register provides post-mask signals: interrupt sources that have been masked will not be updated. The Interrupt Status Register gives the user the status of all bits that could potentially cause an interrupt regardless of whether they have been masked. Truth Table V gives a detailed explanation of the use of these registers.

Pin Configurations (1,2,3)

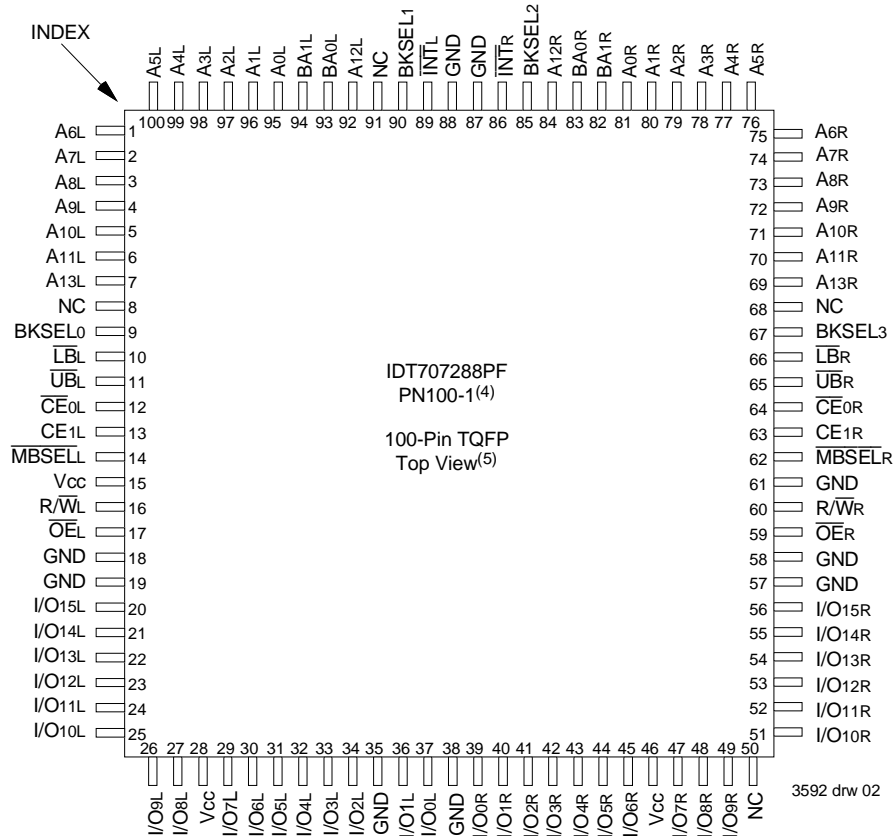

NOTES:

1. All Vcc pins must be connected to power supply.
2. All GND pins must be connected to ground supply.
3. Package body is approximately 14mm x 14mm x 1.4mm.
4. This package code is used to reference the package diagram.
5. This text does not indicate orientation of the actual part-marking.

Pin Names

A0 - A13 ^(1,6)	Address Inputs
BA0 - BA1 ⁽¹⁾	Bank Address Inputs
MBSEL ⁽¹⁾	Mailbox Access Control Gate
BKSEL0-3 ⁽²⁾	Bank Select Inputs
R/W ⁽¹⁾	Read/Write Enable
O \bar{E} ⁽¹⁾	Output Enable
CE $\bar{0}$, CE $\bar{1}$ ⁽¹⁾	Chip Enables
UB, LB ⁽¹⁾	I/O Byte Enables
I/O0 - I/O15 ⁽¹⁾	Bidirectional Data Input/Output
INT ⁽¹⁾	Interrupt Flag (Output) ⁽³⁾
Vcc ⁽⁴⁾	+5V Power
GND ⁽⁵⁾	Ground

NOTES:

1. Duplicated per port.
2. Each bank has an input pin assigned that allows the user to toggle the assignment of that bank between the two ports. Refer to Truth Table IV for more details. When changing the bank assignments, accesses of the affected banks must be suspended. Accesses may continue uninterrupted in banks that are not being reallocated.
3. Generated upon mailbox access.
4. All Vcc pins must be connected to power supply.
5. All GND pins must be connected to ground supply.
6. The first six address pins (A0-A5) for each port serve dual functions. When MBSEL = VIH, the pins serve as memory address inputs. When MBSEL = VIL, the pins serve as mailbox address inputs (A6-A13 are ignored).

Truth Table I – Chip Enable(1,2,3,4)

\overline{CE}	\overline{CE}_0	CE_1	Mode
L	V_{IL}	V_{IH}	Port Selected (TTL Active)
	$\leq 0.2V$	$\geq V_{CC} - 0.2V$	Port Selected (CMOS Active)
H	V_{IH}	X	Port Deselected (TTL Inactive)
	X	V_{IL}	Port Deselected (TTL Inactive)
	$\geq V_{CC} - 0.2V$	X	Port Deselected (CMOS Inactive)
	X	$\leq 0.2V$	Port Deselected (CMOS Inactive)

3592 tbl 02

NOTES:

1. Chip Enable references are shown above with the actual \overline{CE}_0 and CE_1 levels; \overline{CE} is a reference only.
2. Port "A" and "B" references are located where \overline{CE} is used.
3. "H" = V_{IH} and "L" = V_{IL} .
4. \overline{CE} and \overline{MBSEL} cannot both be active at the same time.

Truth Table II – Non-Contention Read/Write Control

Inputs ⁽¹⁾						Outputs		Mode
$\overline{CE}^{(2)}$	R/ \overline{W}	\overline{OE}	\overline{UB}	\overline{LB}	\overline{MBSEL}	I/O ₈₋₁₅	I/O ₀₋₇	
H	X	X	X	X	H	High-Z	High-Z	Deselected: Power-Down
X ⁽³⁾	X	X	H	H	X ⁽³⁾	High-Z	High-Z	Both Bytes Deselected
L	L	X	L	H	H	DATA _{IN}	High-Z	Write to Upper Byte Only
L	L	X	H	L	H	High-Z	DATA _{IN}	Write to Lower Byte Only
L	L	X	L	L	H	DATA _{IN}	DATA _{IN}	Write to Both Bytes
L	H	L	L	H	H	DATA _{OUT}	High-Z	Read Upper Byte Only
L	H	L	H	L	H	High-Z	DATA _{OUT}	Read Lower Byte Only
L	H	L	L	L	H	DATA _{OUT}	DATA _{OUT}	Read Both Bytes
X ⁽³⁾	X	H	X	X	X ⁽³⁾	High-Z	High-Z	Outputs Disabled

3592 tbl 03

NOTES:

1. BA_{0L} - BA_{1L} ≠ BA_{0R} - BA_{1R}: cannot access same bank simultaneously from both ports.
2. Refer to Truth Table I.
3. \overline{CE} and \overline{MBSEL} cannot both be active at the same time.

Truth Table III – Mailbox Read/Write Control⁽¹⁾

Inputs						Outputs		Mode
$\overline{CE}^{(2)}$	R/ \overline{W}	\overline{OE}	\overline{UB}	\overline{LB}	\overline{MBSEL}	I/O ₈₋₁₅	I/O ₀₋₇	
H	H	L	X ⁽³⁾	X ⁽³⁾	L	DATA _{OUT}	DATA _{OUT}	Read Data from Mailbox, ↓ clears interrupt
H	H	L	L	L	L	DATA _{OUT}	DATA _{OUT}	Read Data from Mailbox, ↓ clears interrupt
H	L	X	L ⁽³⁾	L ⁽³⁾	L	DATA _{IN}	DATA _{IN}	Write Data into Mailbox
L	X	X	X	X	L	—	—	Not Allowed

3592 tbl 04

NOTES:

1. There are four mailbox locations per port written to and read from all the I/O's (I/O₀-I/O₁₅). These four mailboxes are addressed by A₀-A₅. Refer to Truth Table V.
2. Refer to Truth Table I.
3. Each mailbox location contains a 16-bit word, controllable in bytes by setting input levels to \overline{UB} and \overline{LB} appropriately.

Absolute Maximum Ratings⁽¹⁾

Symbol	Rating	Commercial & Industrial	Unit
V _{TERM} ⁽²⁾	Terminal Voltage with Respect to GND	-0.5 to +7.0	V
T _{BIAS}	Temperature Under Bias	-55 to +125	°C
T _{STG}	Storage Temperature	-65 to +150	°C
I _{OUT}	DC Output Current	50	mA

3592 tbl 05

NOTES:

- Stresses greater than those listed under ABSOLUTE MAXIMUM RATINGS may cause permanent damage to the device. This is a stress rating only and functional operation of the device at these or any other conditions above those indicated in the operational sections of this specification is not implied. Exposure to absolute maximum rating conditions for extended periods may affect reliability.
- V_{TERM} must not exceed V_{CC} + 10% for more than 25% of the cycle time or 10ns maximum, and is limited to ≤ 20mA for the period of V_{TERM} ≥ V_{CC} + 10%.

Capacitance⁽¹⁾**(T_A = +25°C, f = 1.0MHz) TQFP Package**

Symbol	Parameter	Conditions ⁽²⁾	Max.	Unit
C _{IN}	Input Capacitance	V _{IN} = 3dV	9	pF
C _{OUT} ⁽³⁾	Output Capacitance	V _{OUT} = 3dV	10	pF

3592 tbl 08

NOTES:

- This parameter is determined by device characterization but is not production tested.
- 3dV represents the interpolated capacitance when the input and output signals switch from 0V to 3V or from 3V to 0V.
- C_{OUT} represents C_{IO} as well.

Maximum Operating Temperature and Supply Voltage⁽¹⁾

Grade	Ambient Temperature	GND	V _{CC}
Commercial	0°C to +70°C	0V	5.0V ± 10%
Industrial	-40°C to +85°C	0V	5.0V ± 10%

3592 tbl 06

NOTES:

- This is the parameter T_A. This is the "instant on" case temperature.

Recommended DC Operating Conditions

Symbol	Parameter	Min.	Typ.	Max.	Unit
V _{CC}	Supply Voltage	4.5	5.0	5.5	V
GND	Ground	0	0	0	V
V _{IH}	Input High Voltage	2.2	—	6.0 ⁽²⁾	V
V _{IL}	Input Low Voltage	-0.5 ⁽¹⁾	—	0.8	V

3592 tbl 07

NOTES:

- V_{IL} ≥ -1.5V for pulse width less than 10ns.
- V_{TERM} must not exceed V_{CC} + 10%.

DC Electrical Characteristics Over the Operating Temperature and Supply Voltage Range (V_{CC} = 5.0V ± 10%)

Symbol	Parameter	Test Conditions	707288S		707288L		Unit
			Min.	Max.	Min.	Max.	
I _L	Input Leakage Current ⁽¹⁾	V _{CC} = 5.5V, V _{IN} = 0V to V _{CC}	—	10	—	5	μA
I _{LO}	Output Leakage Current	$\overline{CE} = V_{IH}$, $\overline{MBSEL} = V_{IH}$, V _{OUT} = 0V to V _{CC}	—	10	—	5	μA
V _{OL}	Output Low Voltage	I _{OL} = +4mA	—	0.4	—	0.4	V
V _{OH}	Output High Voltage	I _{OH} = -4mA	2.4	—	2.4	—	V

3592 tbl 09

NOTE:

- At V_{CC} ≤ 2.0V, input leakages are undefined.

DC Electrical Characteristics Over the Operating Temperature and Supply Voltage Range^(1,6) (V_{CC} = 5.0V ± 10%)

Symbol	Parameter	Test Condition	Version	707288X15 Com'l Only		707288X20 Com'l & Ind		707288X25 Com'l & Ind		Unit	
				Typ. ⁽²⁾	Max.	Typ. ⁽²⁾	Max.	Typ. ⁽²⁾	Max.		
I _{CC}	Dynamic Operating Current (Both Ports Active)	$\overline{CE} = V_{IL}$, Outputs Disabled $\overline{MBSEL} = V_{IH}$ $f = f_{MAX}^{(3)}$	COM'L	S	220	350	200	340	190	330	mA
				L	220	300	200	290	190	280	
I _{SB1}	Standby Current (Both Ports - TTL Level Inputs)	$\overline{CE} = \overline{CE}_R = V_{IH}$ $\overline{MBSEL}_R = \overline{MBSEL}_L = V_{IH}$ $f = f_{MAX}^{(3)}$	COM'L	S	50	90	45	90	40	90	mA
				L	50	65	45	65	40	65	
I _{SB2}	Standby Current (One Port - TTL Level Inputs)	$\overline{CE}^A = V_{IL}$ and $\overline{CE}^B = V_{IH}^{(5)}$ Active Port Outputs Disabled, $f = f_{MAX}^{(3)}$ $\overline{MBSEL}_R = \overline{MBSEL}_L = V_{IH}$	COM'L	S	130	230	120	215	110	200	mA
				L	130	200	120	185	110	170	
I _{SB3}	Full Standby Current (Both Ports - All CMOS Level Inputs)	Both Ports \overline{CE}_L and $\overline{CE}_R \geq V_{CC} - 0.2V$ $V_{IN} \geq V_{CC} - 0.2V$ or $V_{IN} < 0.2V$, $f = 0^{(4)}$ $\overline{MBSEL}_R = \overline{MBSEL}_L \geq V_{CC} - 0.2V$	COM'L	S	1.5	15	1.5	15	1.5	15	mA
				L	1.5	5	1.5	5	1.5	5	
I _{SB4}	Full Standby Current (One Port - All CMOS Level Inputs)	$\overline{CE}^A \leq 0.2V$ and $\overline{CE}^B \geq V_{CC} - 0.2V^{(6)}$ $\overline{MBSEL}_R = \overline{MBSEL}_L \geq V_{CC} - 0.2V$ $V_{IN} \geq V_{CC} - 0.2V$ or $V_{IN} < 0.2V$ Active Port Outputs Disabled $f = f_{MAX}^{(3)}$	COM'L	S	145	230	135	210	130	200	mA
				L	145	195	135	180	130	170	
			IND	S	—	—	135	230	130	220	
				L	—	—	135	200	130	190	

3592 tbl 10

NOTES:

- 'X' in part numbers indicates power rating (S or L).
- V_{CC} = 5V, T_A = +25°C, and are not production tested. I_{CCDC} = 120mA (Typ.)
- At f = f_{MAX}, address and control lines (except Output Enable) are cycling at the maximum frequency read cycle of 1/ t_{rc}, and using "AC Test Conditions" of input levels of GND to 3V.
- f = 0 means no address or control lines change.
- Port "A" may be either left or right port. Port "B" is the opposite from port "A".
- Refer to Truth Table I.

AC Test Conditions

Input Pulse Levels	GND to 3.0V
Input Rise/Fall Times	3ns Max.
Input Timing Reference Levels	1.5V
Output Reference Levels	1.5V
Output Load	Figures 1,2 and 3

3592 tbl 11

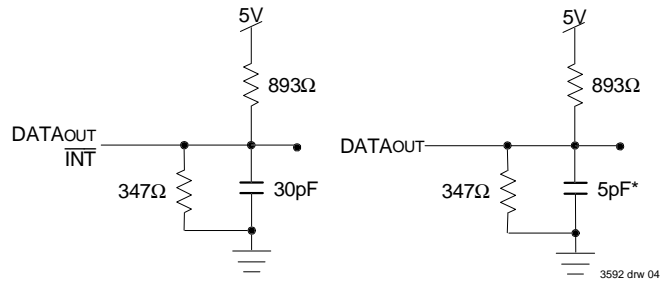
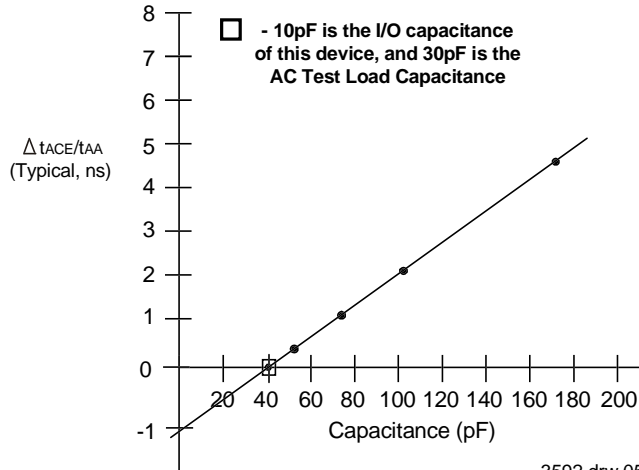

Figure 1. AC Output Test Load

Figure 2. Output Test Load
(for tLZ, tHZ, tWZ, tOW)
*Including scope and jig.



3592 drw 05

Figure 3. Lumped Capacitance Load Typical Derating Curve

AC Electrical Characteristics Over the Operating Temperature and Supply Voltage Range⁽⁴⁾

Symbol	Parameter	707288X15 Com'l Only		707288X20 Com'l & Ind		707288X25 Com'l & Ind		Unit
		Min.	Max.	Min.	Max.	Min.	Max.	
READ CYCLE								
t _{RC}	Read Cycle Time	15	—	20	—	25	—	ns
t _{AA}	Address Access Time	—	15	—	20	—	25	ns
t _{ACE}	Chip Enable Access Time ⁽³⁾	—	15	—	20	—	25	ns
t _{ABE}	Byte Enable Access Time ⁽³⁾	—	15	—	20	—	25	ns
t _{AOE}	Output Enable Access Time	—	9	—	10	—	11	ns
t _{OH}	Output Hold from Address Change	3	—	3	—	3	—	ns
t _{LZ}	Output Low-Z Time ^(1,2)	0	—	0	—	0	—	ns
t _{HZ}	Output High-Z Time ^(1,2)	—	8	—	9	—	10	ns
t _{PU}	Chip Enable to Power Up Time ^(2,5)	0	—	0	—	0	—	ns
t _{PD}	Chip Disable to Power Down Time ^(2,5)	—	15	—	20	—	25	ns
t _{MOP}	Mailbox Flag Update Pulse (OE or MBSEL)	10	—	10	—	10	—	ns
t _{MAA}	Mailbox Address Access Time	—	15	—	20	—	25	ns

3592 tbl 12

NOTES:

1. Transition is measured 0mV from Low or High-impedance voltage with Output Test Load (Figure 2).
2. This parameter is guaranteed by device characterization, but is not production tested.
3. To access RAM, $\overline{CE} = V_{IL}$ and $\overline{MBSEL} = V_{IH}$. To access mailbox, $\overline{CE} = V_{IH}$ and $\overline{MBSEL} = V_{IL}$.
4. 'X' in part numbers indicates power rating (S or L).
5. Refer to Truth Table I.

Assigning the Banks via the External Bank Selects

There are four bank select pins available on the IDT707288, and each of these pins is associated with a specific bank within the memory array. The pins are user-controlled inputs: access to a specific bank is assigned to a particular port by setting the input to the appropriate level. The process of assigning the banks is detailed in Truth Table IV. Once a bank is assigned to a port, the owning port has full access to read and write within that bank. The opposite port is unable to access that bank until the user reassigns the port. Access by a port to a bank which it does not control will have no effect

if written, and if read unknown values on D0-D15 will be returned. Each port can be assigned as many banks within the array as needed, up to and including all four banks.

The bank select pin inputs must be set at either V_{IH} or V_{IL} - these inputs are not tri-statable. When changing the bank assignments, accesses of the affected banks must be suspended. Accesses may continue uninterrupted in banks that are not being reallocated.

Truth Table IV – Memory Bank Assignment ($\overline{CE} = V_{IH}$)^(2,3)

BKSEL0	BKSEL1	BKSEL2	BKSEL3	BANK AND DIRECTION ⁽¹⁾
H	X	X	X	BANK 0 LEFT
X	H	X	X	BANK 1 LEFT
X	X	H	X	BANK 2 LEFT
X	X	X	H	BANK 3 LEFT
L	X	X	X	BANK 0 RIGHT
X	L	X	X	BANK 1 RIGHT
X	X	L	X	BANK 2 RIGHT
X	X	X	L	BANK 3 RIGHT

NOTES:

3592 tbl 13

- Bank 0 refers to the first 16Kx16 memory spaces, Bank 1 to the second 16Kx16 memory spaces, Bank 2 to the third 16Kx16 memory spaces, and Bank 3 to the fourth 16Kx16 memory spaces. 'LEFT' indicates the bank is assigned to the left port; 'RIGHT' indicates the bank is assigned to the right port. 0-4 banks may be assigned to either port.
- The bank select pin inputs must be set at either V_{IH} or V_{IL} - these inputs are not tri-statable. When changing the bank assignments, accesses of the affected banks must be suspended. Accesses may continue uninterrupted in banks that are not being reallocated.
- 'H' = V_{IH} , 'L' = V_{IL} , 'X' = Don't Care.

Mailbox Interrupts and Interrupt Control Registers

If the user chooses the mailbox interrupt function, four mailbox locations are assigned to each port. These mailbox locations are external to the memory array. The mailboxes are accessed by setting $\overline{MBSEL} = V_{IL}$ while holding $\overline{CE} = V_{IH}$.

The mailboxes are 16 bits wide and controllable by byte: the message is user-defined since these are addressable SRAM locations. An interrupt is generated to the opposite port upon writing to the upper byte of any mailbox location. A port can read the message it has just written in order to verify it: this read will not alter the status of the interrupt sent to the opposite port. The interrupted port can clear the interrupt by reading the upper byte of the applicable mailbox. This read will not alter the contents of the mailbox. The use of mailboxes to generate interrupts to the opposite port and the reading of mailboxes to clear interrupts is detailed in Truth Table V.

If desired, any of the mailbox interrupts can be independently masked via software. Masking of the interrupt sources is done in the Mask Register.

The masks are individual and independent: a port can mask any combination of interrupt sources with no effect on the other sources. Each port can modify only its own Mask Register. The use of this register is detailed in Truth Table V.

Two registers are provided to permit interpretation of interrupts: these are the Interrupt Cause Register and the Interrupt Status Register. The Interrupt Cause Register gives the user a snapshot of what has caused the interrupt to be generated - the specific mailbox written to by the opposite port. The information in this register provides post-mask signals: interrupt sources that have been masked will not be updated. The Interrupt Status Register gives the user the status of all bits that could potentially cause an interrupt regardless of whether they have been masked. The use of the Interrupt Cause Register and the Interrupt Status Register is detailed in Truth Table V.

Truth Table V – Mailbox Interrupts ($\overline{CE} = V_{IH}$)^(8,9)

\overline{MB} SEL	R/W	\overline{UB}	\overline{LB}	A5	A4	A3	A2	A1	A0	D0	D1	D2	D3	D4	D5	D6	D7	D8	D9	D10	D11	D12	D13	D14	D15	DESCRIPTION
L	X	X	X	L	L	L	L	L	L	RESERVED (7)															RESERVED (7)	
L	X	X	X	:	:	:	:	:	:	RESERVED (7)															RESERVED (7)	
L	(1)	(1)	(1)	H	L	L	L	L	L	X	X	X	X	X	X	X	X	X	X	X	X	X	X	X	X	MAILBOX 0 - SET INTERRUPT ON OPPOSITE PORT
L	(1)	(1)	(1)	H	L	L	L	L	H	X	X	X	X	X	X	X	X	X	X	X	X	X	X	X	X	MAILBOX 1 - SET INTERRUPT ON OPPOSITE PORT
L	(1)	(1)	(1)	H	L	L	L	H	L	X	X	X	X	X	X	X	X	X	X	X	X	X	X	X	X	MAILBOX 2 - SET INTERRUPT ON OPPOSITE PORT
L	(1)	(1)	(1)	H	L	L	L	H	H	X	X	X	X	X	X	X	X	X	X	X	X	X	X	X	X	MAILBOX 3 - SET INTERRUPT ON OPPOSITE PORT
↑	H	(2)	(2)	H	L	L	H	L	L	X	X	X	X	X	X	X	X	X	X	X	X	X	X	X	X	MAILBOX 0 - CLEAR OPPOSITE PORT INTERRUPT
↑	H	(2)	(2)	H	L	L	H	L	H	X	X	X	X	X	X	X	X	X	X	X	X	X	X	X	X	MAILBOX 1 - CLEAR OPPOSITE PORT INTERRUPT
↑	H	(2)	(2)	H	L	L	H	H	L	X	X	X	X	X	X	X	X	X	X	X	X	X	X	X	X	MAILBOX 2 - CLEAR OPPOSITE PORT INTERRUPT
↑	H	(2)	(2)	H	L	L	H	H	H	X	X	X	X	X	X	X	X	X	X	X	X	X	X	X	X	MAILBOX 3 - CLEAR OPPOSITE PORT INTERRUPT
L	(3)	(3)	(3)	H	L	H	L	L	L	(4)	(4)	(4)	(4)	(5)	(5)	(5)	(5)	(6)	(6)	(6)	(6)	X	X	X	X	MAILBOX INTERRUPT CONTROLS
L	X	X	X	:	:	:	:	:	:	RESERVED (7)															RESERVED (7)	
L	X	X	X	H	H	H	H	H	H	RESERVED (7)															RESERVED (7)	

3592 tbl 14

NOTES:

- There are four independent mailbox locations available to each side, external to the standard memory array. The mailboxes can be written to in either 8-bit or 16-bit widths. The upper byte of each mailbox has an associated interrupt to the opposite port. The mailbox interrupts can be individually masked if desired, and the status of the interrupt determined by polling the Interrupt Status Register (see Note 6 for this table). A port can read its own mailboxes to verify the data written, without affecting the interrupt which is sent to the opposite port.
- These registers allow a port to read the data written to a specific mailbox location by the opposite port. Reading the upper byte of the data in a particular mailbox clears the interrupt associated with that mailbox without modifying the data written. Once the address and R/W are stable, the actual clearing of the interrupt is triggered by the transition of MBSEL from V_{IH} to V_{IL} .
- This register contains the Mask Register (bits D0-D3), the Interrupt Cause Register (bits D4-D7), and the Interrupt Status Register (bits D8-D11). The controls for R/W, \overline{UB} , and \overline{LB} are manipulated in accordance with the appropriate function. See Notes 4, 5, and 6 for this table. Bits D12-D15 are "Don't Care".
- This register, the Mask Register, allows the user to independently mask the various interrupt sources. Writing V_{IH} to the appropriate bit (D0 = Mailbox 0, D1 = Mailbox 1, D2 = Mailbox 2, and D3 = Mailbox 3) disables the interrupt, while writing V_{IL} enables the interrupt. All four bits in this register must be written at the same time. This register can be read at any time to verify the mask settings. The masks are individual and independent: any single interrupt source can be masked with no effect on the other sources. Each port can modify only its own mask settings.
- This register, the Interrupt Cause Register, gives the user a snapshot of what has caused the interrupt to be generated. Reading V_{OL} for a specific bit (D4 = Mailbox 0, D5 = Mailbox 1, D6 = Mailbox 2, and D7 = Mailbox 3) indicates that the associated interrupt source has generated an interrupt. Acknowledging the interrupt clears the bit in this register (see Note 2 for this table). This register provides post-mask information: if the interrupt source has been masked, the associated bit in this register will not update.
- This register, the Interrupt Status Register, gives the user the status of all interrupt sources that could potentially cause an interrupt regardless of whether they have been masked. Reading V_{OL} for a specific bit (D8 = Mailbox 0, D9 = Mailbox 1, D10 = Mailbox 2, and D11 = Mailbox 3) indicates that the associated interrupt source has generated an interrupt. Acknowledging the interrupt clears the associated bit in this register (see Note 2 for this table). This register provides pre-mask information: regardless of whether an interrupt source has been masked, the associated bit in this register will update.
- Access to registers defined as "RESERVED" will have no effect, if written, and if read unknown values on D0-D15 will be returned.
- These registers are not guaranteed to initialize in any known state. At power-up, the initialization sequence should include the set-up of these registers.
- 'L' = V_{IL} or V_{OL} , 'H' = V_{IH} or V_{OH} , 'X' = Don't Care.

Waveform of Read Cycles⁽⁴⁾

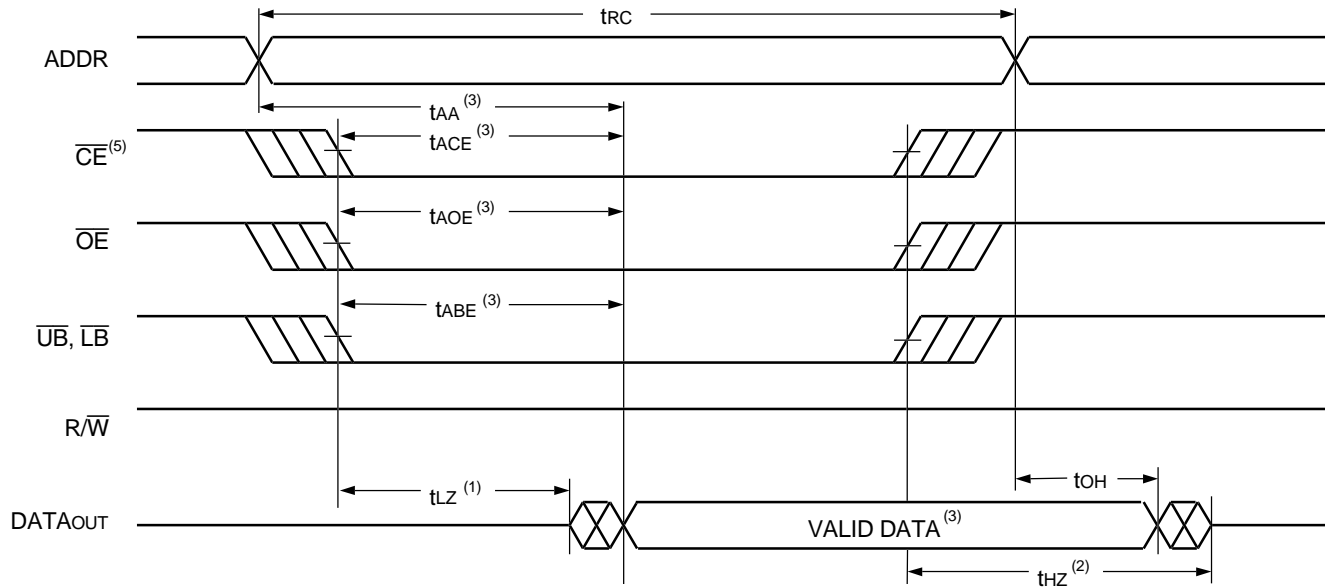

NOTES:

1. Timing depends on which signal is asserted last, \overline{CE} , \overline{OE} , \overline{LB} , or \overline{UB} .
2. Timing depends on which signal is de-asserted first \overline{CE} , \overline{OE} , \overline{LB} , or \overline{UB} .
3. Start of valid data depends on which timing becomes effective last: t_{AOE} , t_{ACE} , t_{ABE} or t_{AA} .
4. $\overline{MBSEL} = V_{IH}$.
5. Refer to Truth Table I.

3592 drw 06

Timing of Power-Up Power-Down

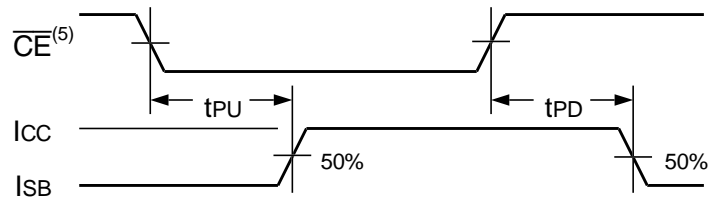

3592 drw 07

AC Electrical Characteristics Over the Operating Temperature and Supply Voltage⁽⁵⁾

Symbol	Parameter	707288X15 Com'l Only		707288X20 Com'l & Ind		707288X25 Com'l & Ind		Unit
		Min.	Max.	Min.	Max.	Min.	Max.	
WRITE CYCLE								
t _{WC}	Write Cycle Time	15	—	20	—	25	—	ns
t _{EW}	Chip Enable to End-of-Write ⁽³⁾	12	—	15	—	20	—	ns
t _{AW}	Address Valid to End-of-Write	12	—	15	—	20	—	ns
t _{AS}	Address Set-up Time ⁽³⁾	0	—	0	—	0	—	ns
t _{BS}	Bank Set-up Time	0	—	0	—	0	—	ns
t _{WP}	Write Pulse Width	12	—	15	—	20	—	ns
t _{WR}	Write Recovery Time	0	—	0	—	0	—	ns
t _{DW}	Data Valid to End-of-Write	15	—	15	—	20	—	ns
t _{HZ}	Output High-Z Time ^(1,2)	—	8	—	9	—	10	ns
t _{DH}	Data Hold Time ⁽⁴⁾	0	—	0	—	0	—	ns
t _{WZ}	Write Enable to Output in High-Z ^(1,2)	—	8	—	9	—	10	ns
t _{OW}	Output Active from End-of-Write ^(1,2,4)	3	—	3	—	3	—	ns
t _{MWRD}	Mailbox Write to Read Time	5	—	5	—	5	—	ns

3592 tbl 15

NOTES:

- Transition is measured 0mV from Low or High-impedance voltage with Output Test Load (Figure 2).
- This parameter is guaranteed by device characterization, but is not production tested.
- To access RAM, $\overline{CE} = V_{IL}$ and $\overline{MBSEL} = V_{IH}$. To access mailbox, $\overline{CE} = V_{IH}$ and $\overline{MBSEL} = V_{IL}$. Either condition must be valid for the entire t_{EW} time. Refer to Truth Tables I and III.
- The specification for t_{DH} must be met by the device supplying write data to the RAM under all operating conditions. Although t_{DH} and t_{OW} values will vary over voltage and temperature, the actual t_{DH} will always be smaller than the actual t_{OW}.
- 'X' in part numbers indicates power rating (S or L).

Timing Waveform of Write Cycle No. 1, R/\overline{W} Controlled Timing^(1,5,8)

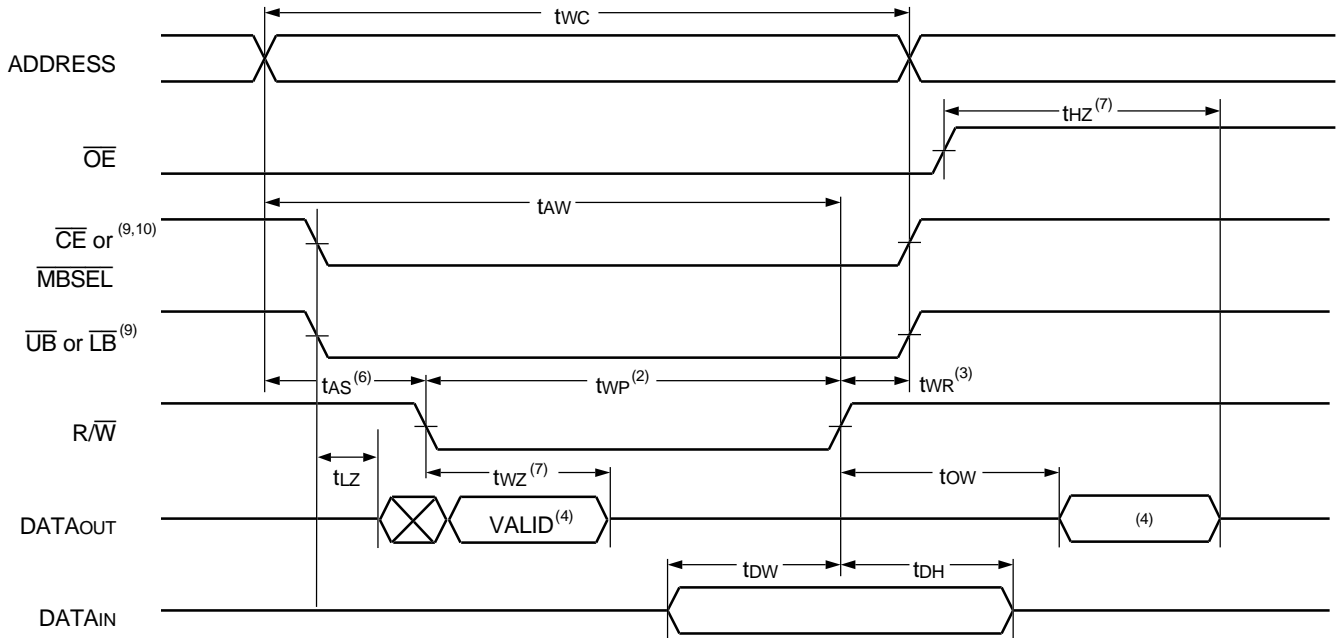

3592 drw 08

Timing Waveform of Write Cycle No. 2, \overline{CE} , \overline{UB} , \overline{LB} Controlled Timing^(1,5)

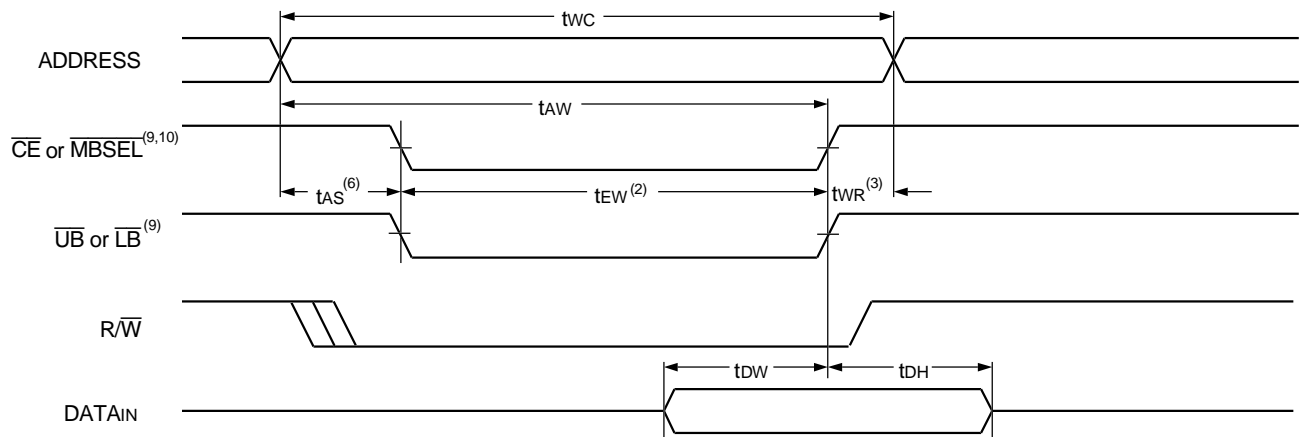

3592 drw 09

NOTES:

1. R/\overline{W} or \overline{CE} or \overline{UB} and $\overline{LB} = V_{IH}$ during all address transitions.
2. A write occurs during the overlap (t_{EW} or t_{WP}) of a $\overline{CE} = V_{IL}$ and a $R/\overline{W} = V_{IL}$ for memory array writing cycle.
3. t_{WR} is measured from the earlier of \overline{CE} or R/\overline{W} (or \overline{MBSEL} or R/\overline{W}) going to V_{IL} to the end of write cycle.
4. During this period, the I/O pins are in the output state and input signals must not be applied.
5. If the \overline{CE} or $\overline{MBSEL} = V_{IL}$ transition occurs simultaneously with or after the $R/\overline{W} = V_{IL}$ transition, the outputs remain in the High-impedance state.
6. Timing depends on which enable signal is asserted last, \overline{CE} or R/\overline{W} .
7. This parameter is guaranteed by device characterization, but is not production tested. Transition is measured 0mV from steady state with the Output Test Load (Figure 2).
8. If $\overline{OE} = V_{IL}$ during R/\overline{W} controlled write cycle, the write pulse width must be the larger of t_{WP} or $(t_{WZ} + t_{DW})$ to allow the I/O drivers to turn off and data to be placed on the bus for the required t_{OW} . If $\overline{OE} = V_{IH}$ during an R/\overline{W} controlled write cycle, this requirement does not apply and the write pulse can be as short as the specified t_{WP} .
9. To access RAM, $\overline{CE} = V_{IL}$ and $\overline{MBSEL} = V_{IH}$. To access mailboxes, $\overline{CE} = V_{IH}$ and $\overline{MBSEL} = V_{IL}$. t_{EW} must be met for either condition.
10. Refer to Truth Table I.

Timing Waveform of Left Port Write to right Port Read of Same Data^(1,2,3)

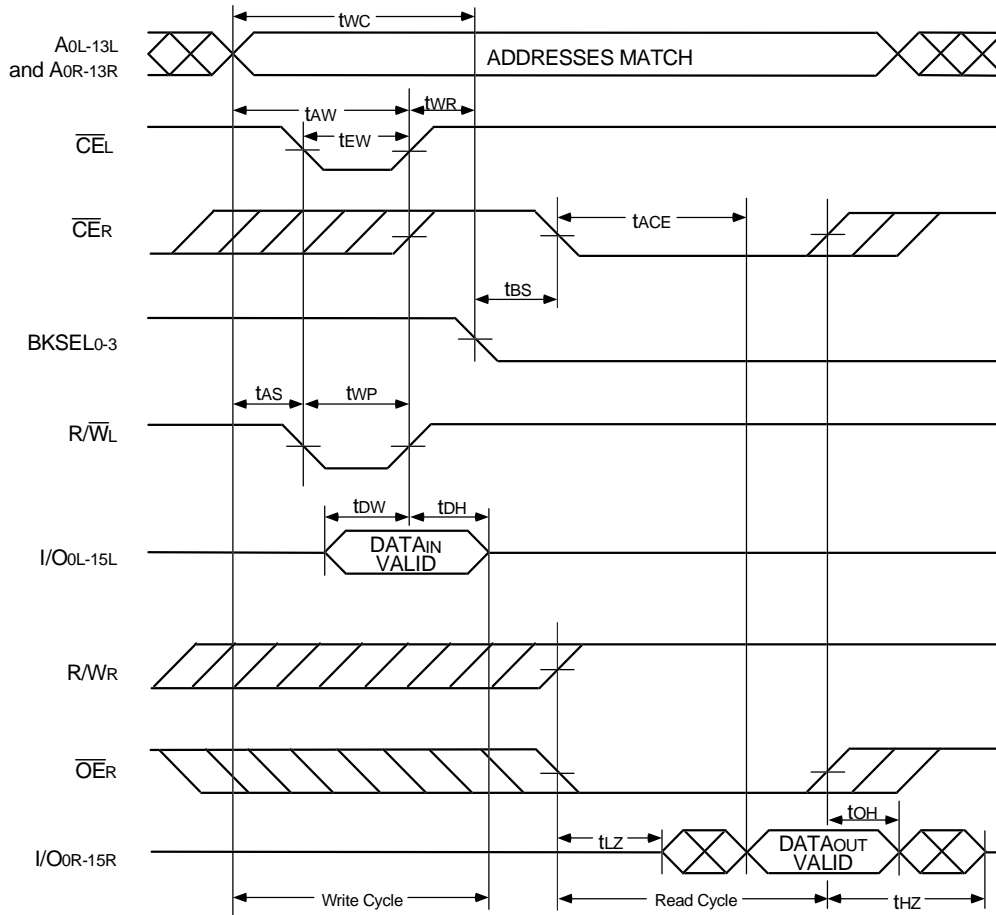

3592 drw 10

NOTES:

1. \overline{UB} and \overline{LB} are controlled as necessary to enable the desired byte accesses.
2. Timing for Right Port Write to Left Port Read is identical.
3. Refer to Truth Table I and IV.

Timing Waveform of Mailbox Read after Write Timing, Either Side^(1,2)

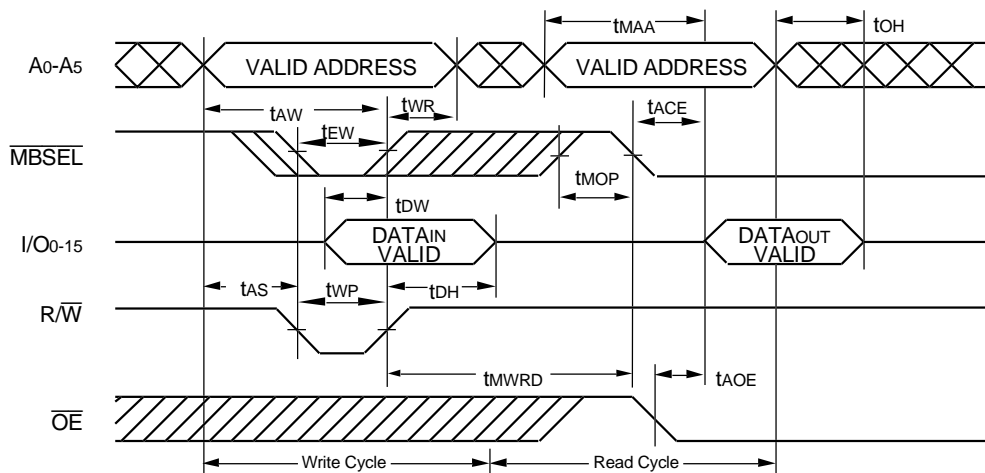

3592 drw 11

NOTES:

1. $\overline{CE} = V_{IH}$ for the duration of the above timing (both write and read cycle), refer to Truth Table I.
2. \overline{UB} and \overline{LB} are controlled as necessary to enable the desired byte accesses.

AC Electrical Characteristics Over the Operating Temperature and Supply Voltage Range⁽¹⁾

Symbol	Parameter	707288X15 Com'l Only		707288X20 Com'l & Ind		707288X25 Com'l & Ind		Unit
		Min.	Max.	Min.	Max.	Min.	Max.	
INTERRUPT TIMING								
t _{AS}	Address Set-up Time	0	—	0	—	0	—	ns
t _{WR}	Write Recovery Time	0	—	0	—	0	—	ns
t _{INS}	Interrupt Set Time	—	15	—	20	—	25	ns
t _{INR}	Interrupt Reset Time	—	15	—	20	—	25	ns

3592 tbl 16

NOTES:

- 'X' in part numbers indicates power rating (S or L).

Waveform of Interrupt Timing^(1,5)

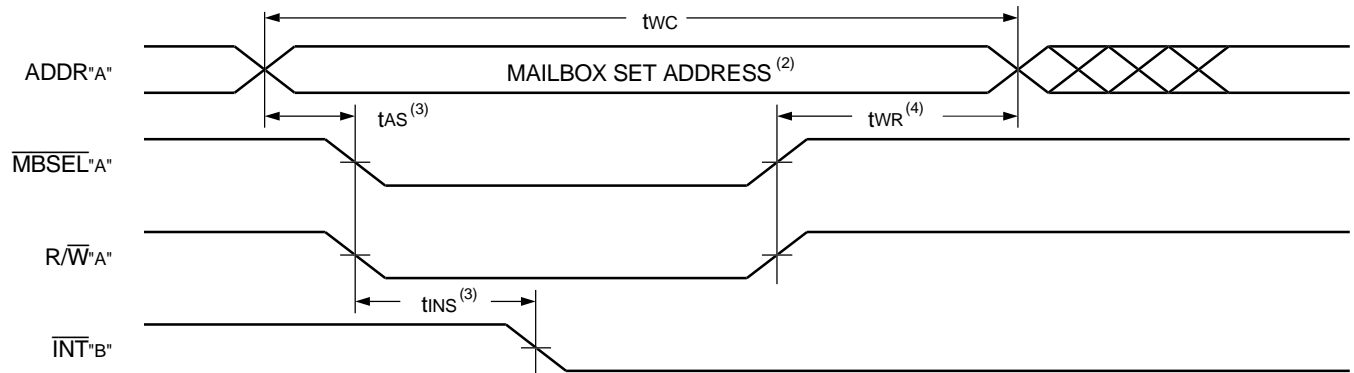

3592 drw 12

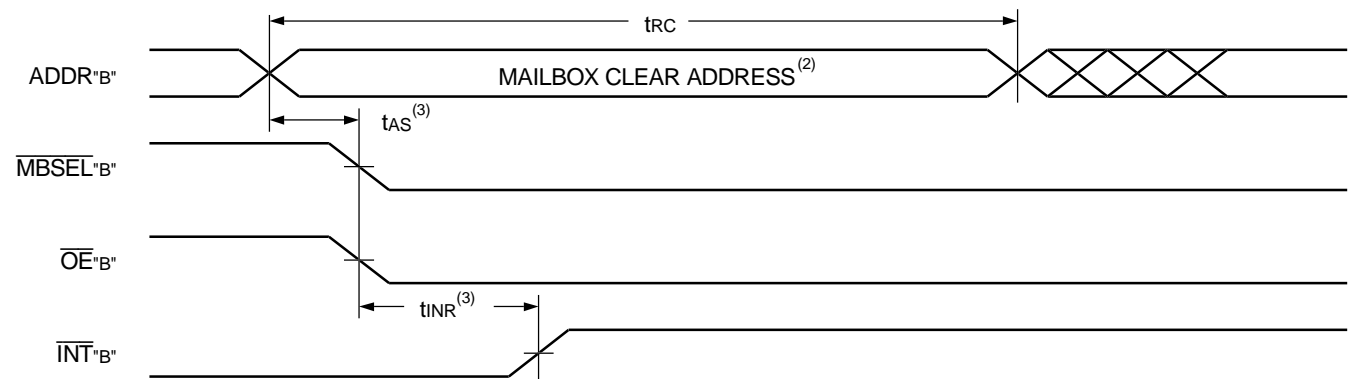

3592 drw 13

NOTES:

- All timing is the same for left and right ports. Port "A" may be either the left or right port. Port "B" is the port opposite from port "A".
- See Interrupt Truth Table V.
- Timing depends on which enable signal (\overline{CE} or R/\overline{W}) is asserted last.
- Timing depends on which enable signal (\overline{CE} or R/\overline{W}) is de-asserted first.
- Refer to Truth Table I.

Depth and Width Expansion

The IDT707288 features dual chip enables (refer to Truth Table I) in order to facilitate rapid and simple depth expansion with no requirements for external logic. Figure 4 illustrates how to control the various chip enables in order to expand two devices in depth.

The IDT707288 can also be used in applications requiring expanded

width, as indicated in Figure 4. Since the banks are allocated at the discretion of the user, the external controller can be set up to drive the input signals for the various devices as required to allow for 32-bit or wider applications.

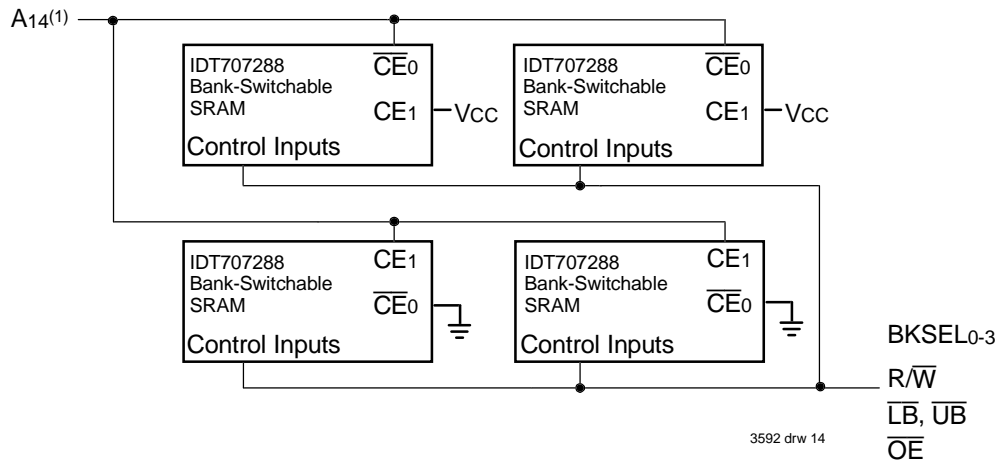
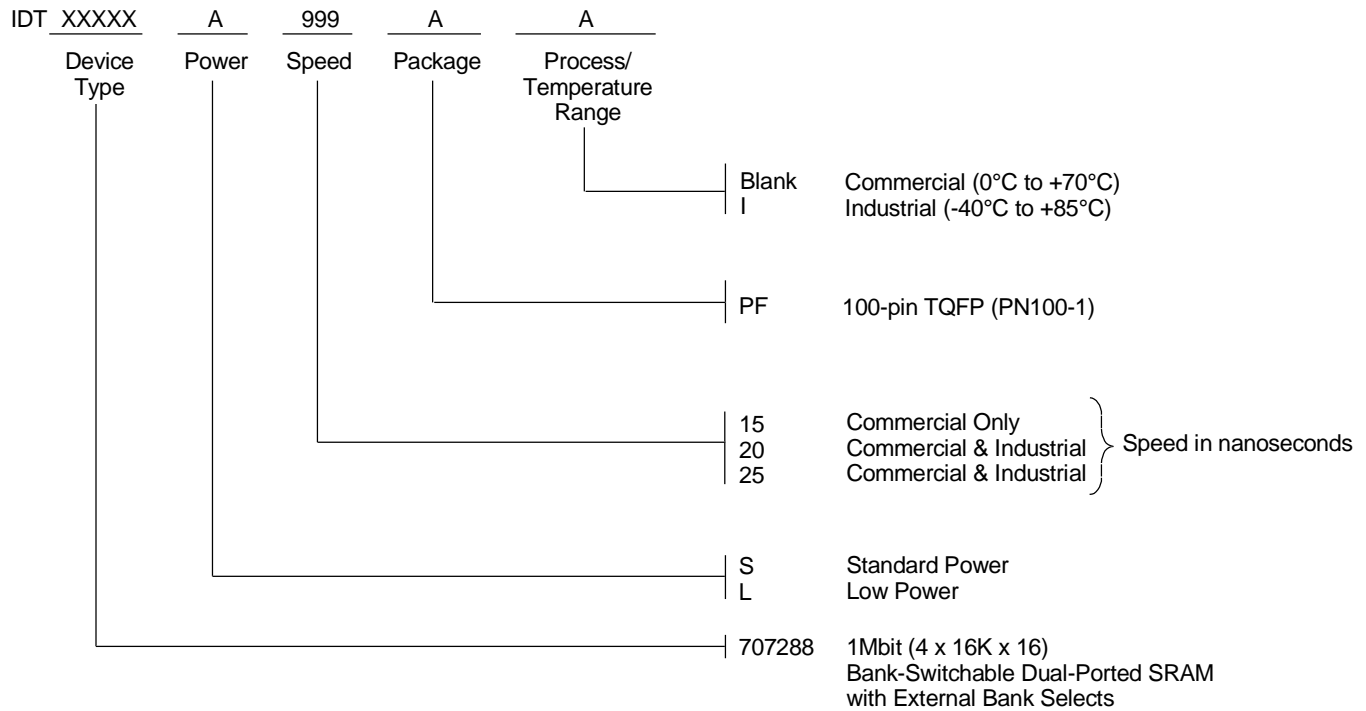

Figure 4. Depth and Width Expansion with IDT707288

NOTE:

1. This signal is provided by external logic. It is not a bit present on the address bus.

Ordering Information



3592 drw 15

Datasheet Document History

- 1/18/99: Initiated datasheet document history
Converted to new format
Cosmetic and typographical corrections
Page 2 Added additional notes to pin configurations
- 3/11/99: Removed preliminary note
Cosmetic and typographical corrections
- 6/4/99: Changed drawing format
Page 1 Corrected DSC number
- 3/10/00: Added Industrial Temperature Ranges and removed corresponding notes
Replaced IDT logo
Page 1 Made overbar correction on drawing
Changed ±200mV to 0mV in notes
- 5/23/00: Page 5 Increased storage temperature parameter
Clarified TA parameter
Page 6 DC Electrical parameters—changed wording from "open" to "disabled"



CORPORATE HEADQUARTERS
 2975 Stender Way
 Santa Clara, CA 95054

for SALES:
 800-345-7015 or 408-727-6116
 fax: 408-492-8674
 www.idt.com

for Tech Support:
 831-754-4613
 DualPortHelp@idt.com

The IDT logo is a registered trademark of Integrated Device Technology, Inc.



LittleDiode supplies new, hard to find or obsolete electronic components and semiconductors all over the world.

With over two million different components listed you are sure to find the part you need.

Feel free to visit us today at our online store:

LittleDiode.com

Looking forward to providing you with the best possible service.