



HIGH-SPEED 36K (4K x 9-BIT) SYNCHRONOUS PIPELINED DUAL-PORT SRAM

IDT709149S

Features

- ◆ Architecture based on Dual-Port SRAM cells
 - Allows full simultaneous access from both ports
- ◆ High-speed clock-to-data output times
 - Commercial: 8/10/12ns (max.)
- ◆ Low-power operation
 - IDT709149S
 - Active: 1500mW (typ.)
 - Standby: 75mW (typ.)
- ◆ 4K X 9 bits
- ◆ Synchronous operation
 - 4ns setup to clock, 1ns hold on all control, data, and address inputs
 - Data input, address, and control registers
 - Fast 8ns clock to data out

- ◆ 13ns cycle time, 76MHz operation in pipeline mode
 - Self-timed write allows for fast cycle times
- ◆ TTL-compatible, singles 5V ($\pm 10\%$) power supply
- ◆ Clock Enable feature
- ◆ Guaranteed data output hold times
- ◆ Industrial temperature range (-40°C to $+85^{\circ}\text{C}$) is available for selected speeds.

Description

The IDT709149 is a high-speed 4K x 9 bit synchronous Dual-Port SRAM. The memory array is based on Dual-Port memory cells to allow simultaneous access from both ports. Registers on control, data, and address inputs provide low set-up and hold times. The timing latitude provided by this approach will allow systems to be designed with very

Functional Block Diagram

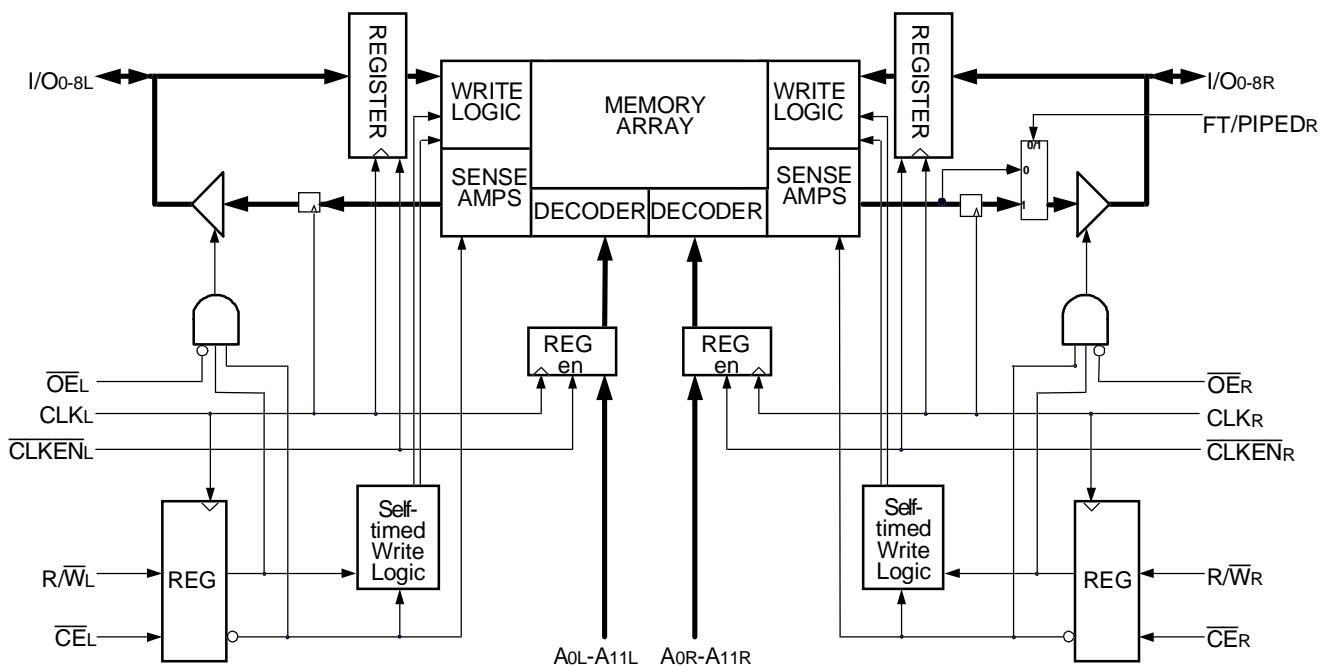

3494 drw 01

SEPTEMBER 1999

short cycle times. This device has been optimized for applications having unidirectional data flow or bi-directional data flow in bursts, by utilizing input data registers.

The IDT709149 utilizes a 9-bit wide data path to allow for parity at the user's option. This feature is especially useful in data communication applications where it is necessary to use a parity bit for transmission/reception error checking.

Fabricated using IDT's CMOS high-performance technology, these Dual-Ports typically operate on only 800mW of power at maximum high-speed clock-to-data output times as fast as 8ns. An automatic power down feature, controlled by \overline{CE} , permits the on-chip circuitry of each port to enter a very low standby power mode.

The IDT709149 is packaged in an 80-pin TQFP.

Pin Configurations^(1,2,3)

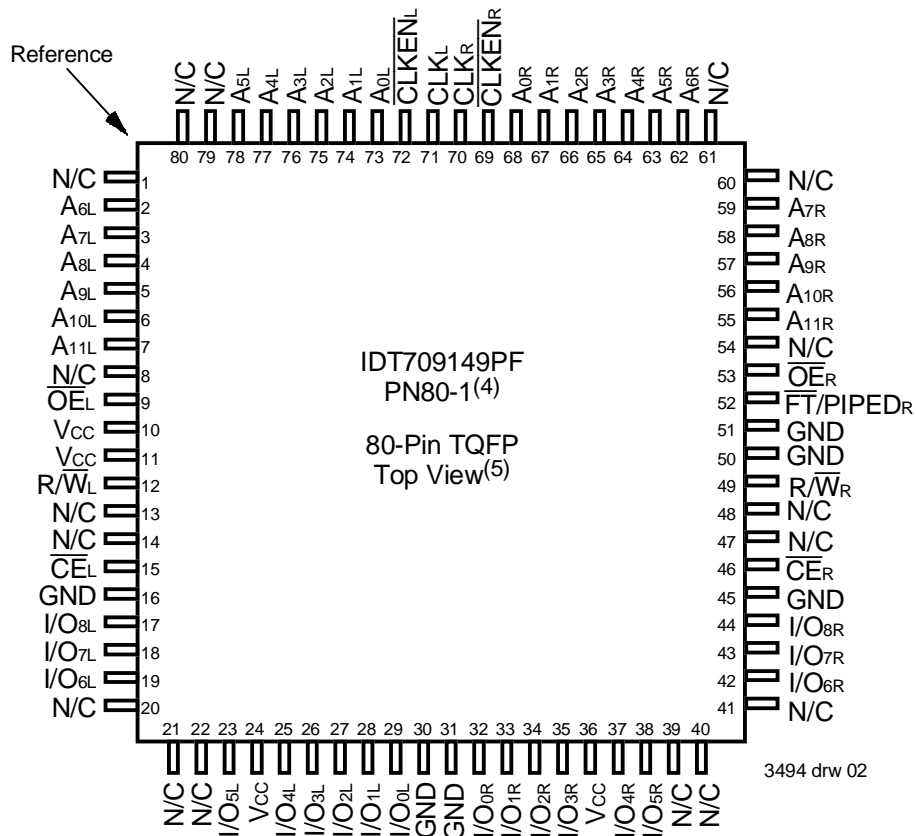

NOTES:

1. All Vcc pins must be connected to power supply.
2. All ground pins must be connected to ground supply.
3. Package body is approximately 14mm x 14mm x 1.4mm.
4. This package code is used to reference the package diagram.
5. This text does not indicate the orientation of the actual part-marking.

Absolute Maximum Ratings⁽¹⁾

Symbol	Rating	Commercial & Industrial	Unit
$V_{TERM}^{(2)}$	Terminal Voltage with Respect to GND	-0.5 to +7.0	V
$V_{TERM}^{(2)}$	Terminal Voltage	-0.5 to V_{CC}	V
T_{BIAS}	Temperature Under Bias	-55 to +125	°C
T_{STG}	Storage Temperature	-55 to +125	°C
I_{OUT}	DC Output Current	50	mA

3494 tbl 01

NOTES:

- Stresses greater than those listed under ABSOLUTE MAXIMUM RATINGS may cause permanent damage to the device. This is a stress rating only and functional operation of the device at these or any other conditions above those indicated in the operational sections of this specification is not implied. Exposure to absolute maximum rating conditions for extended periods may affect reliability.
- V_{TERM} must not exceed $V_{CC} + 10\%$ for more than 25% of the cycle time or 10ns maximum, and is limited to $\leq 20mA$ for the period of $V_{TERM} \geq V_{CC} + 10\%$.

Capacitance ($T_A = +25^\circ C$, $f = 1.0MHz$)

Symbol	Parameter	Conditions	Max.	Unit
C_{IN}	Input Capacitance	$V_{IN} = 3dV$	8	pF
C_{OUT}	Output Capacitance	$V_{OUT} = 3dV$	9	pF

3494 tbl 04

NOTES:

- These parameters are determined by device characterization, but are not production tested.
- 3dV references the interpolated capacitance when the input and output switch from 0V to 3V or from 3V to 0V.

Maximum Operating Temperature and Supply Voltage^(1,2)

Grade	Ambient Temperature	GND	V_{CC}
Commercial	0°C to +70°C	0V	5.0V \pm 10%
Industrial	-40°C to +85°C	0V	5.0V \pm 10%

3494 tbl 02

NOTES:

- This is the parameter T_A .
- Industrial temperature: for specific speeds, packages and powers contact your sales office.

Recommended DC Operating Conditions

Symbol	Parameter	Min.	Typ.	Max.	Unit
V_{CC}	Supply Voltage	4.5	5.0	5.5	V
GND	Ground	0	0	0	V
V_{IH}	Input High Voltage	2.2	—	6.0 ⁽²⁾	V
V_{IL}	Input Low Voltage	-0.5 ⁽¹⁾	—	0.8	V

3494 tbl 03

NOTES:

- $V_{IL} \geq -1.5V$ for pulse width less than 10ns.
- V_{TERM} must not exceed $V_{CC} + 10\%$.

DC Electrical Characteristics Over the Operating Temperature and Supply Voltage Range ($V_{CC} = 5.0V \pm 10\%$)

Symbol	Parameter	Test Conditions	709149S		Unit
			Min.	Max.	
$ I_{L} $	Input Leakage Current ⁽¹⁾	$V_{CC} = 5.5V$, $V_{IN} = 0V$ to V_{CC}	—	10	μA
$ I_{O} $	Output Leakage Current	$V_{OUT} = 0V$ to V_{CC}	—	10	μA
V_{OL}	Output Low Voltage	$I_{OL} = +4mA$	—	0.4	V
V_{OH}	Output High Voltage	$I_{OH} = -4mA$	2.4	—	V

3494 tbl 05

NOTE:

- At $V_{CC} \leq 2.0V$, input leakages are undefined

DC Electrical Characteristics Over the Operating Temperature and Supply Voltage Range^(4,5) (V_{CC} = 5V ± 10%)

Symbol	Parameter	Test Condition	Version	709149S8 Com'l Only		709149S10 Com'l Only		709149S12 Com'l Only		Unit
				Typ.	Max.	Typ.	Max.	Typ.	Max.	
I _{CC}	Dynamic Operating Current (Both Ports Active)	$\overline{CE_L}$ and $\overline{CE_R} = V_{IL}$, Outputs Open $f = f_{MAX}^{(1)}$	COM'L	—	320	—	310	—	300	mA
			IND	—	—	—	—	—	—	
I _{SB1}	Standby Current (Both Ports - TTL Level Inputs)	$\overline{CE_L}$ and $\overline{CE_R} = V_{IH}$ $f = f_{MAX}^{(1)}$	COM'L	—	150	—	150	—	140	mA
			IND	—	—	—	—	—	—	
I _{SB2}	Standby Current (One Port - TTL Level Inputs)	$\overline{CE_{A^*}} = V_{IL}$ and $\overline{CE_{B^*}} = V_{IH}^{(3)}$ Active Port Outputs Open, $f = f_{MAX}^{(1)}$	COM'L	—	230	—	220	—	210	mA
			IND	—	—	—	—	—	—	
I _{SB3}	Full Standby Current (Both Ports - All CMOS Level Inputs)	$\overline{CE_L}$ and $\overline{CE_R} \geq V_{CC} - 0.2V$, $V_{IN} \geq V_{CC} - 0.2V$ or $V_{IN} \leq 0.2V$, $f = 0^{(2)}$	COM'L	—	15	—	15	—	15	mA
			IND	—	—	—	—	—	—	
I _{SB4}	Full Standby Current (One Port - All CMOS Level Inputs)	$\overline{CE_{A^*}} \leq 0.2V$ and $\overline{CE_{B^*}} \geq V_{CC} - 0.2V^{(3)}$ $V_{IN} \geq V_{CC} - 0.2V$ or $V_{IN} \leq 0.2V$ Active Port Outputs Open, $f = f_{MAX}^{(1)}$	COM'L	—	220	—	210	—	200	mA
			IND	—	—	—	—	—	—	

3494 tbl 06

NOTES:

- At $f = f_{MAX}$, address and control lines (except Output Enable) are cycling at the maximum frequency clock cycle of $1/t_{CLK}$, using "AC TEST CONDITIONS" at input levels of GND to 3V.
- $f = 0$ means no address, clock, or control lines change. Applies only to input at CMOS level standby.
- Port "A" may be either left or right port. Port "B" is the opposite from port "A".
- $V_{CC} = 5V$, $T_A = 25^\circ C$ for Typ, and are not production tested. $I_{CC DC} = 150mA$ (Typ).
- Industrial temperature: for specific speeds, packages and powers contact your sales office.

AC Test Conditions

Input Pulse Levels	GND to 3.0V
Input Rise/Fall Times	3ns Max.
Input Timing Reference Levels	1.5V
Output Reference Levels	1.5V
Output Load	Figures 1,2 and 3

3494 tbl 07

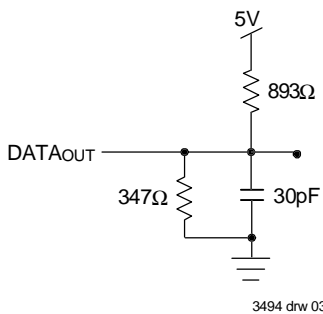

3494 drw 03

Figure 1. AC Output Test load.

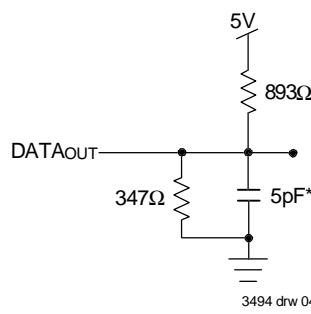

3494 drw 04

Figure 2. Output Test Load (For t_{CKLZ} , t_{CKHZ} , t_{OLZ} , and t_{OHZ}).
*Including scope and jig.

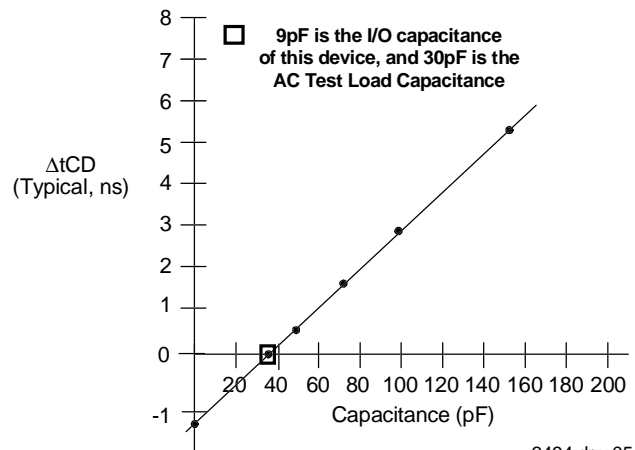

3494 drw 05

Figure 3. Typical Output Derating (Lumped Capacitive Load).

AC Electrical Characteristics Over the Operating Temperature Range— (Read and Write Cycle Timing)⁽⁴⁾

(Commercial: $V_{CC} = 5V \pm 10\%$, $T_A = 0^\circ\text{C}$ to $+70^\circ\text{C}$)

Symbol	Parameter	709149S8 Com'1 Only		709149S10 Com'1 Only		709124S12 Com'1 Only		Unit
		Min.	Max.	Min.	Max.	Min.	Max.	
t _{CYC1}	Clock Cycle Time (Flow-Through) ⁽³⁾	16	—	20	—	20	—	ns
t _{CYC2}	Clock Cycle Time (Pipelined) ⁽³⁾	13	—	15	—	16	—	ns
t _{CH1}	Clock High Time (Flow-Through) ⁽³⁾	6	—	7	—	8	—	ns
t _{CL1}	Clock Low Time (Flow-Through) ⁽³⁾	6	—	7	—	8	—	ns
t _{CH2}	Clock High Time (Pipelined) ⁽³⁾	6	—	6	—	6	—	ns
t _{CL2}	Clock Low Time (Pipelined) ⁽³⁾	6	—	6	—	6	—	ns
t _{CD1}	Clock to Data Valid (Flow-Through) ⁽³⁾	—	12	—	15	—	20	ns
t _{CD2}	Clock to Data Valid (Pipelined) ⁽³⁾	—	8	—	10	—	12	ns
t _S	Registered Signal Set-up Time	4	—	4	—	5	—	ns
t _H	Registered Signal Hold Time	1	—	1	—	1	—	ns
t _{DC}	Data Output Hold After Clock High	1	—	1	—	1	—	ns
t _{CKLZ}	Clock High to Output Low-Z ^(1,2)	2	—	2	—	2	—	ns
t _{CKHZ}	Clock High to Output High-Z ^(1,2)	—	7	—	7	—	9	ns
t _{OE}	Output Enable to Output Valid	—	8	—	8	—	10	ns
t _{OLZ}	Output Enable to Output Low-Z ^(1,2)	0	—	0	—	0	—	ns
t _{OHZ}	Output Disable to Output High-Z ^(1,2)	—	7	—	7	—	9	ns
t _{CK}	Clock Enable, Disable Set-Up Time	4	—	4	—	5	—	ns
t _{CK}	Clock Enable, Disable Hold Time	1	—	1	—	1	—	ns
t _{WDD}	Write Port Clock High to Read Data Delay	—	25	—	30	—	35	ns

3494 tbl 08

NOTES:

1. Transition is measured $\pm 200\text{mV}$ from Low or High-impedance voltage with the Output Test Load (Figure 2).
2. This parameter is guaranteed by device characterization, but is not production tested.
3. The Pipelined output parameters (t_{CYC2}, t_{CD2}) always apply to the Left Port. The Right Port uses the Pipelined t_{CYC2} and t_{CD2} when $\overline{\text{FT}}/\text{PIPEDR} = V_{IH}$ and the Flow-Through parameters (t_{CYC1}, t_{CD1}) when $\overline{\text{FT}}/\text{PIPEDR} = V_{IL}$.
4. Industrial temperature: for specific speeds, packages and powers contact your sales office.

Timing Waveform of Read Cycle for Flow-Through Output on Right Port ($\overline{FT}/\text{Piped}_R = V_{IL}$)

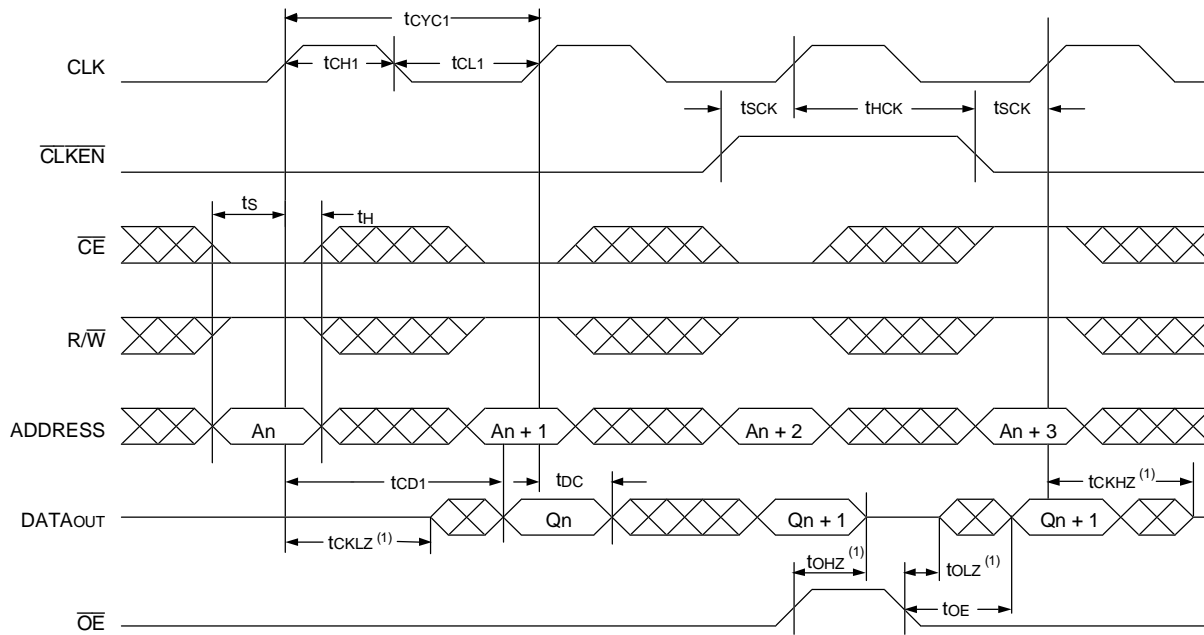

3494 drw 06

Timing Waveform of Left Port Write to Flow-Through Right Port Read ($\overline{FT}/\text{Piped}_R = V_{IL}$)^(2,3)

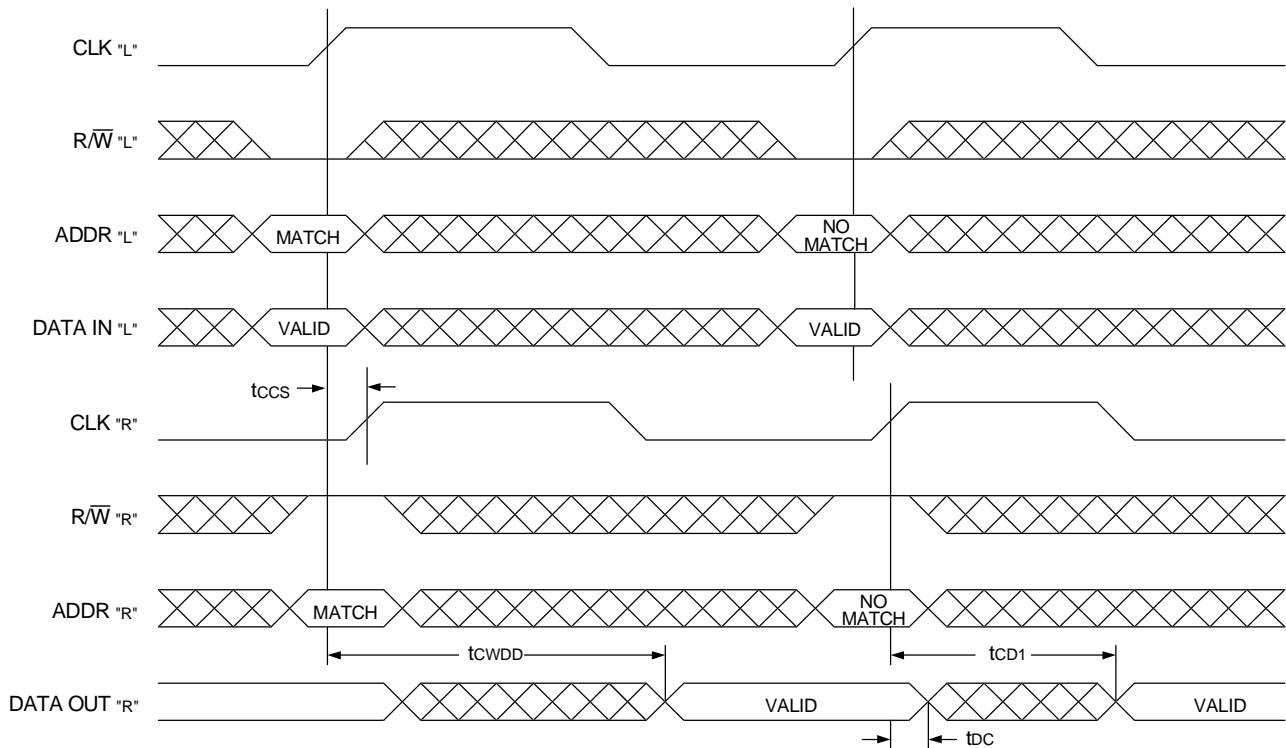

3494 drw 07

NOTES:

1. Transition is measured $\pm 200\text{mV}$ from Low or High-impedance voltage with the Output Test Load (Figure 2).
2. $\overline{CE}_L = \overline{CE}_R = V_{IL}$, $\overline{CLKEN}_L = \overline{CLKEN}_R = V_{IL}$
3. $\overline{OE} = V_{IL}$ for the reading port, port 'R'.

Timing Waveform of Read Cycle for Pipelined Operation (Left Port; Right Port when $\overline{FT}/\text{Piped}_R = V_{IH}$)⁽³⁾

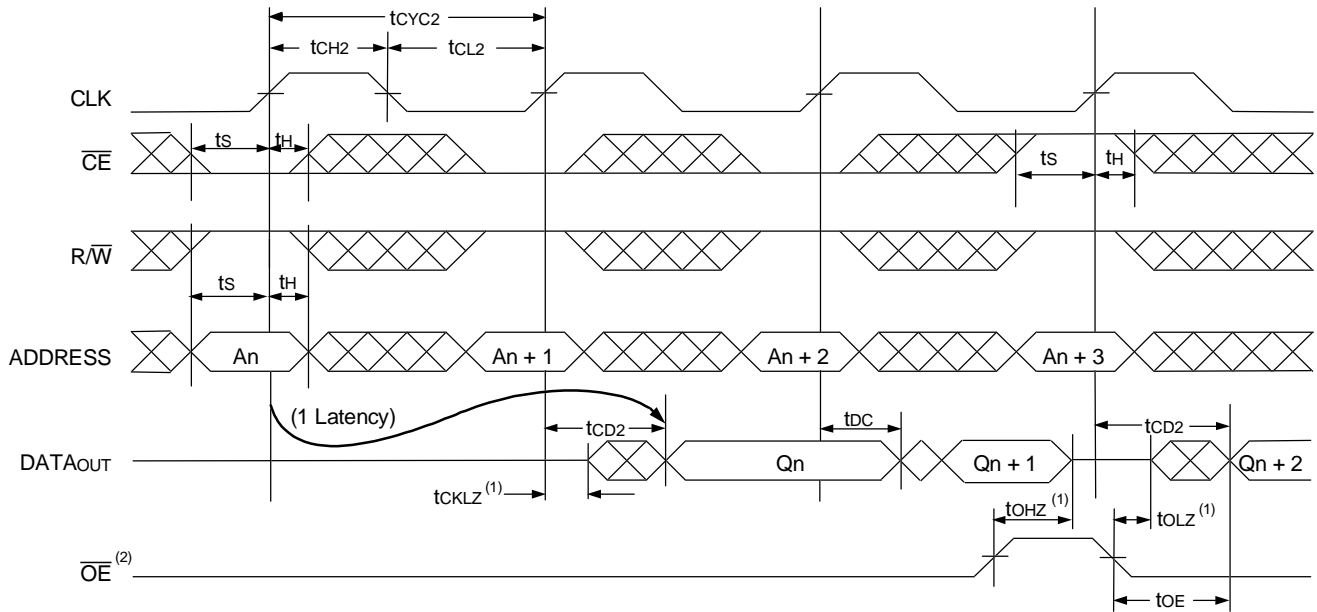

3494 drw 08

NOTES:

1. Transition is measured $\pm 200\text{mV}$ from Low or High-impedance voltage with the Output Test Load (Figure 2).
2. \overline{OE} is asynchronously controlled; all other inputs are synchronous to the rising clock edge.
3. CLKEN_L and $\text{CLKEN}_R = V_{IL}$.

Timing Waveform of Pipelined Read-to-Write-to-Read ($\overline{OE} = V_{IL}$)

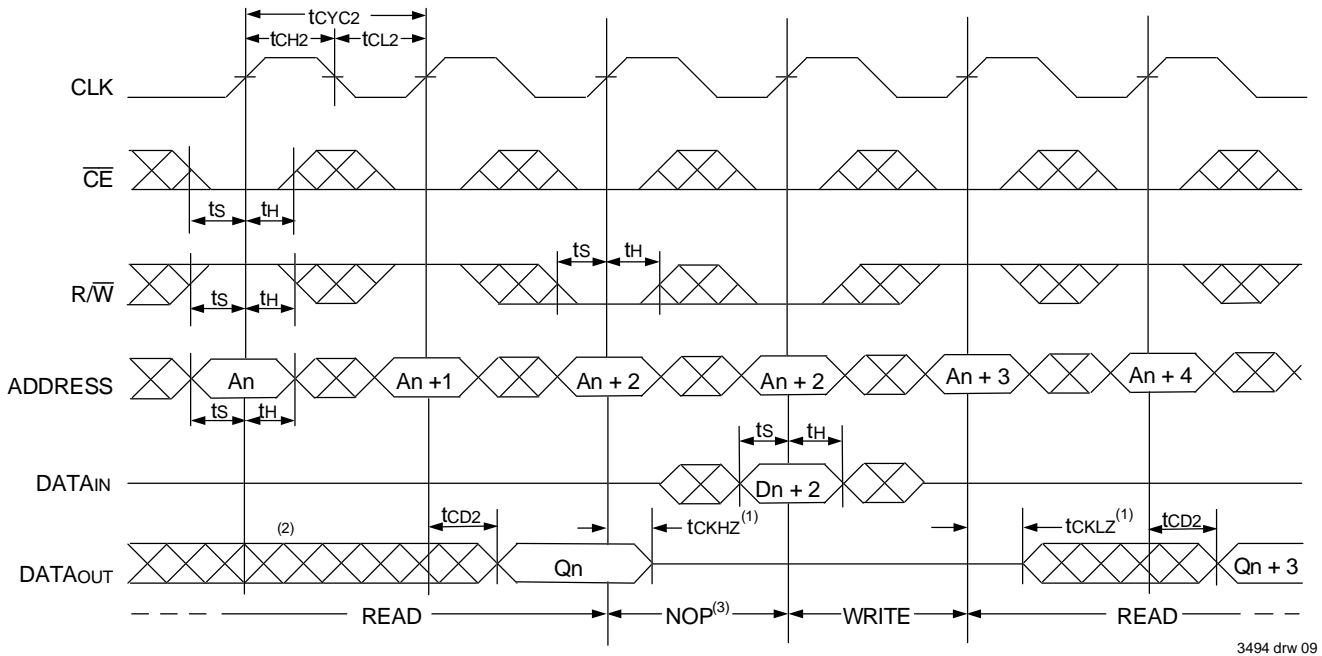

Timing Waveform of Pipelined Read-to-Write-to-Read (\overline{OE} Controlled)

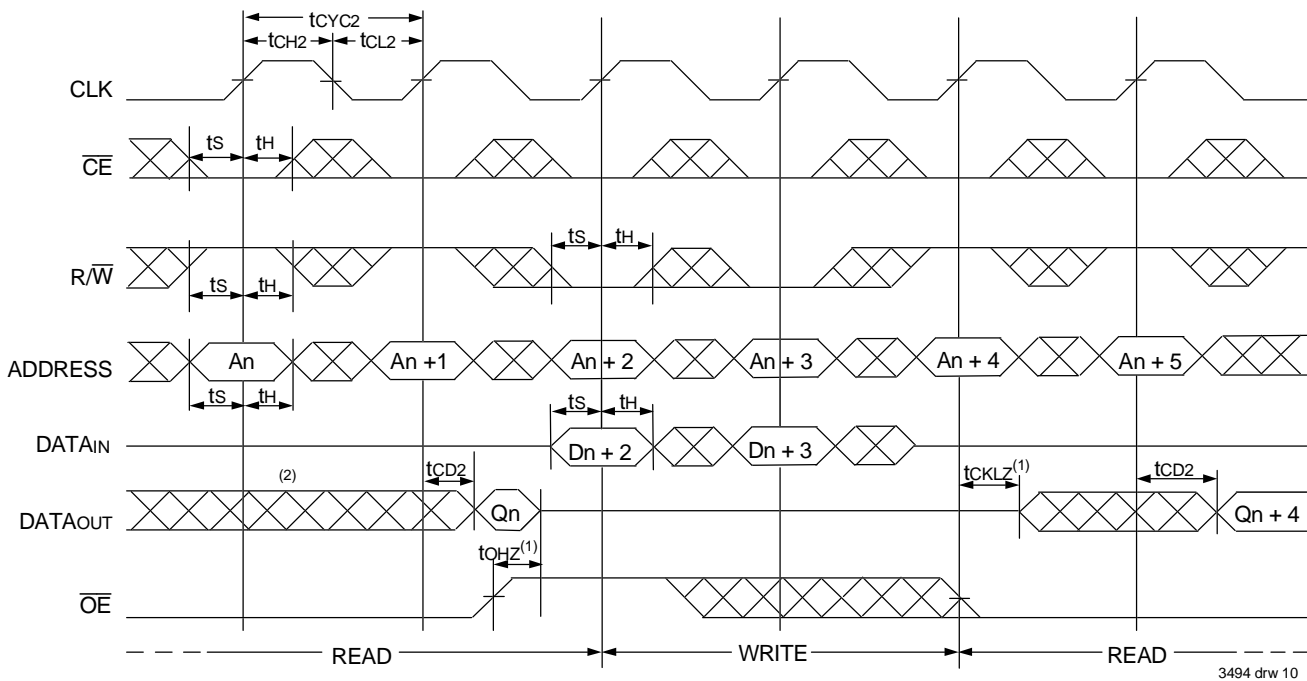

NOTES:

1. Transition is measured $\pm 200\text{mV}$ from Low or High-impedance voltage with the Output Test Load (Figure 2).
2. Output state (High, Low, or High-impedance) is determined by the previous cycle control signals.
3. "NOP" is "No Operation." Data in memory at the selected address may be corrupted and should be re-written to guarantee data integrity.

Functional Description

The IDT709149 provides a true synchronous Dual-Port Static RAM interface. Registered inputs provide very short set-up and hold times on address, data, and all critical control inputs. All internal registers are clocked on the rising edge of the clock signal. An asynchronous output enable is provided to ease asynchronous bus interfacing.

The internal write pulse width is dependent only on the low to high transitions of the clock signal to initiate a write allowing the shortest

possible realized cycle times. Clock enable inputs are provided to stall the operation of the address and data input registers without introducing clock skew for very fast interleaved memory applications.

A HIGH on the \overline{CE} input for one clock cycle will power down the internal circuitry to reduce static power consumption.

When pipelined mode is enabled, two cycles are required with \overline{CE} LOW to reactivate the outputs.

Truth Table I: Read/Write Control⁽¹⁾

Inputs				Outputs	Mode
Synchronous ⁽³⁾			Asynchronous		
CLK	\overline{CE}	R/W	\overline{OE}	I/O ₀₋₈	
↑	H	X	X	High-Z	Deselected—Power Down
↑	L	L	X	DATA _{IN}	Selected and Write Enable
↑	L	H	L	DATA _{OUT}	Read Selected and Data Output Enabled Read (1 Latency)
↑	X	X	H	High-Z	Data I/O Disabled

3494 tbl 09

Truth Table II: Clock Enable Function Table⁽¹⁾

Operating Mode	Inputs		Register Inputs		Register Outputs ⁽⁴⁾	
	CLK ⁽³⁾	\overline{CLKEN} ⁽²⁾	ADDR	DATA _{IN}	ADDR	DATA _{OUT}
Load "1"	↑	L	H	H	H	H
Load "0"	↑	L	L	L	L	L
Hold (do nothing)	↑	H	X	X	NC	NC
	X	H	X	X	NC	NC

3494 tbl 10

NOTES:

- 'H' = HIGH voltage level steady state, 'h' = HIGH voltage level one set-up time prior to the LOW-to-HIGH clock transition, 'L' = LOW voltage level steady state 'l' = LOW voltage level one set-up time prior to the LOW-to-HIGH clock transition, 'X' = Don't care, 'NC' = No change
- \overline{CLKEN} = V_{IL} must be clocked in during Power-Up.
- Control signals are initiated and terminated on the rising edge of the CLK, depending on their input level. When R/W and \overline{CE} are LOW, a write cycle is initiated on the LOW-to-HIGH transition of the CLK. Termination of a write cycle is done on the next LOW-to-HIGH transition of the CLK.
- The register outputs are internal signals from the register inputs being clocked in or disabled by \overline{CLKEN} .

Ordering Information

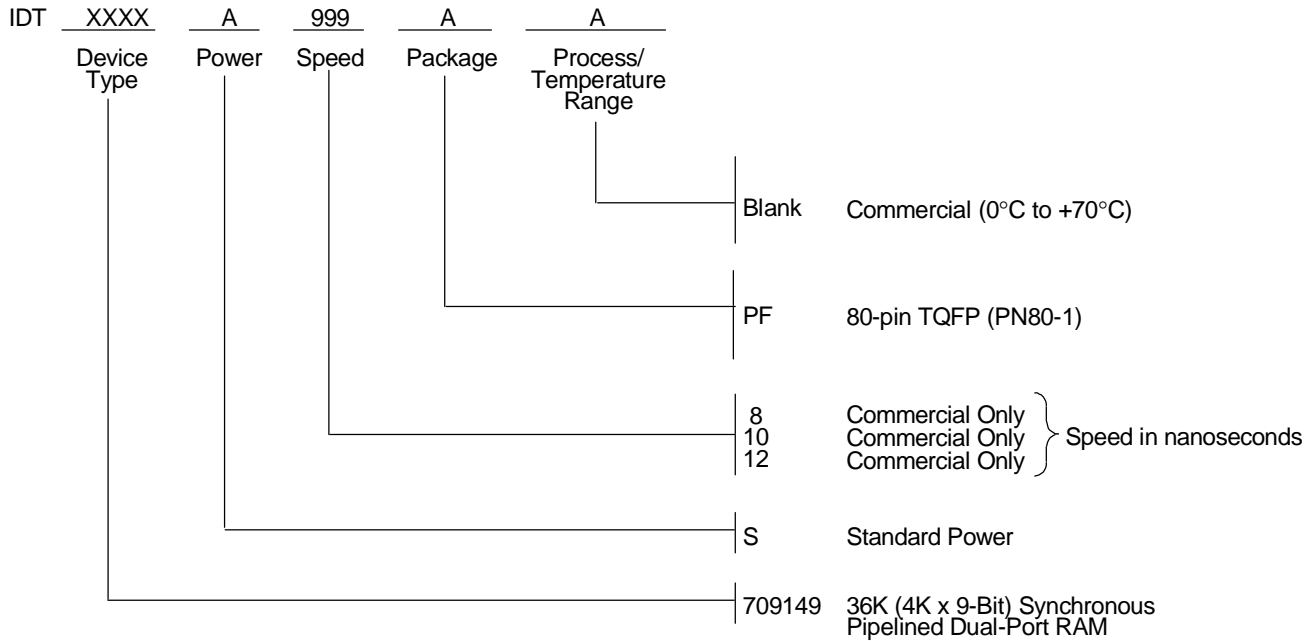

3494 drw 11

NOTE:

1. Industrial temperature range is available.
For specific speeds, packages and powers contact your sales office.

Datasheet Document History

- 3/8/99: Initiated datasheet document history
Converted to new format
Cosmetic and typographical corrections
Added additional notes to pin configurations
- 6/3/99: Changed drawing format
- 9/1/99: Removed Preliminary



CORPORATE HEADQUARTERS
2975 Stender Way
Santa Clara, CA 95054

for SALES:
800-345-7015 or 408-727-6116
fax: 408-492-8674
www.idt.com

for Tech Support:
831-754-4613
DualPortHelp@idt.com

The IDT logo is a registered trademark of Integrated Device Technology, Inc.



LittleDiode supplies new, hard to find or obsolete electronic components and semiconductors all over the world.

With over two million different components listed you are sure to find the part you need.

Feel free to visit us today at our online store:

LittleDiode.com

Looking forward to providing you with the best possible service.