



Integrated Device Technology, Inc.

# CMOS STATIC RAM 256K (32K x 8-BIT)

IDT71256SA

### FEATURES:

- 32K x 8 advanced high-speed CMOS static RAM
- Commercial (0° to 70°C) and Industrial (-40° to 85°C) temperature options
- Equal access and cycle times
  - Commercial: 12/15/20/25ns
  - Industrial: 15/20ns
- One Chip Select plus one Output Enable pin
- Bidirectional data inputs and outputs directly TTL-compatible
- Low power consumption via chip deselect
- Commercial product available in 28-pin 300- and 600-mil Plastic DIP, 300 mil Plastic SOJ and TSOP packages
- Industrial product available in 28-pin 300 mil Plastic SOJ and TSOP packages

### DESCRIPTION:

The ID71256SA is a 262,144-bit high-speed Static RAM organized as 32K x 8. It is fabricated using IDT's high-performance, high-reliability CMOS technology. This state-of-the-art technology, combined with innovative circuit design techniques, provides a cost-effective solution for high-speed memory needs.

The IDT71256SA has an output enable pin which operates as fast as 6ns, with address access times as fast as 12ns. All bidirectional inputs and outputs of the IDT71256SA are TTL-compatible and operation is from a single 5V supply. Fully static asynchronous circuitry is used, requiring no clocks or refresh for operation.

The IDT71256SA is packaged in 28-pin 300- and 600-mil Plastic DIP, 28-pin 300 mil Plastic SOJ and TSOP.

### FUNCTIONAL BLOCK DIAGRAM

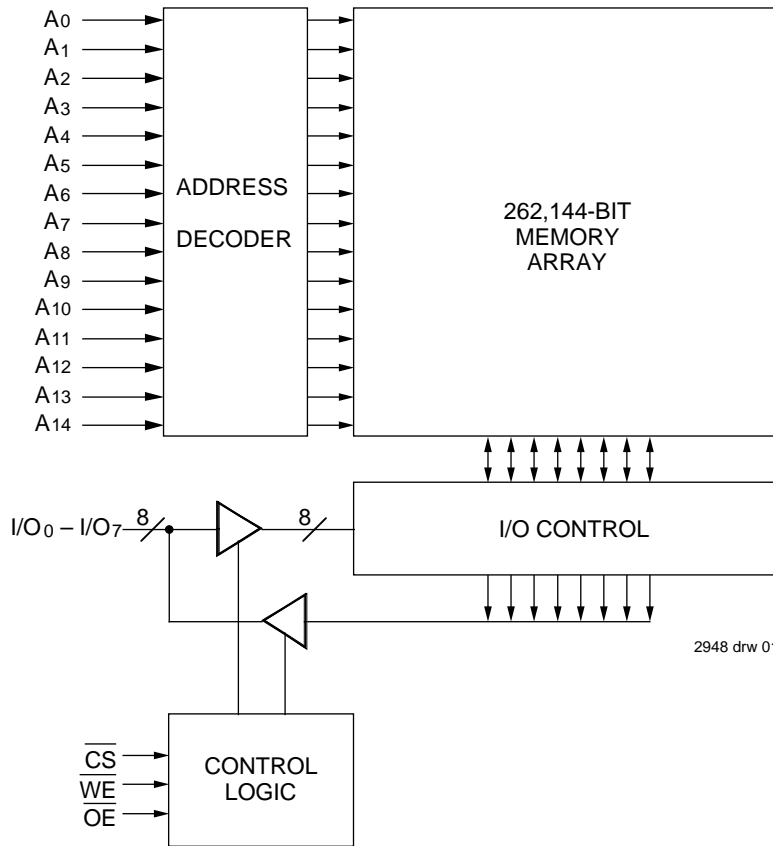

The IDT logo is a registered trademark of Integrated Device Technology, Inc.

**INDUSTRIAL AND COMMERCIAL TEMPERATURE RANGES**

**MAY 1997**

## PIN CONFIGURATIONS

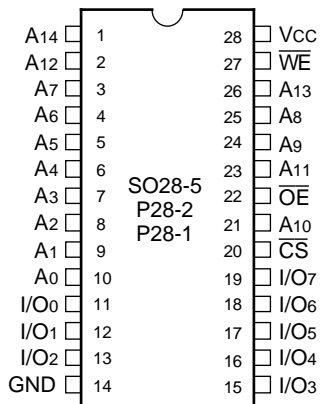

2948 drw 02

DIP/SOJ  
TOP VIEW

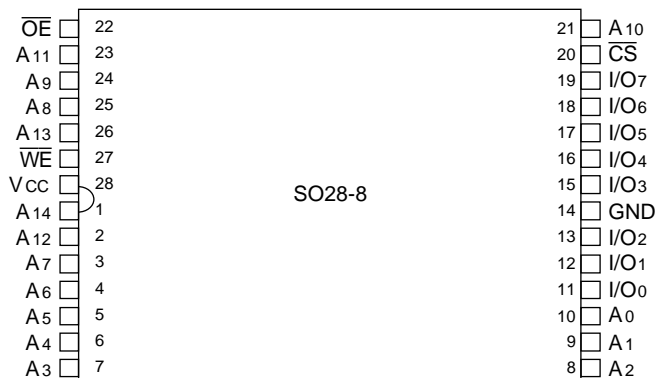

2948 drw 11

TSOP  
TOP VIEW

## RECOMMENDED OPERATING TEMPERATURE AND SUPPLY VOLTAGE

Grade	Temperature	GND	Vcc
Commercial	0°C to +70°C	0V	4.5V to 5.5V
Industrial	-40°C to +85°C	0V	4.5V to 5.5V

3948 tbl 09

## DC ELECTRICAL CHARACTERISTICS

VCC = 5.0V ± 10%

Symbol	Parameter	Test Condition	IDT71256SA		Unit
			Min.	Max.	
I <sub>L</sub>	Input Leakage Current	VCC = Max., V <sub>IN</sub> = GND to VCC	—	5	μA
I <sub>LO</sub>	Output Leakage Current	VCC = Max., CS = V <sub>IH</sub> , V <sub>OUT</sub> = GND to VCC	—	5	μA
V <sub>OL</sub>	Output Low Voltage	I <sub>OL</sub> = 8mA, VCC = Min.	—	0.4	V
V <sub>OH</sub>	Output High Voltage	I <sub>OH</sub> = -4mA, VCC = Min.	2.4	—	V

2948 tbl 05

## ABSOLUTE MAXIMUM RATINGS<sup>(1)</sup>

Symbol	Rating	Value	Unit
VCC	Supply Voltage Relative to GND	-0.5 to +7.0	V
V <sub>TERM</sub>	Terminal Voltage Relative to GND	-0.5 to VCC+0.5	V
T <sub>BIAS</sub>	Temperature Under Bias	-55 to +125	°C
T <sub>STG</sub>	Storage Temperature	-55 to +125	°C
P <sub>T</sub>	Power Dissipation	1.0	W
I <sub>OUT</sub>	DC Output Current	50	mA

### NOTES:

2948 tbl 02

- Stresses greater than those listed under ABSOLUTE MAXIMUM RATINGS may cause permanent damage to the device. This is a stress rating only and functional operation of the device at these or any other conditions above those indicated in the operational sections of this specification is not implied. Exposure to absolute maximum rating conditions for extended periods may affect reliability.

## TRUTH TABLE<sup>(1,2)</sup>

CS	OE	WE	I/O	Function
L	L	H	DATA <sub>OUT</sub>	Read Data
L	X	L	DATA <sub>IN</sub>	Write Data
L	H	H	High-Z	Outputs Disabled
H	X	X	High-Z	Deselected — Standby (I <sub>SB</sub> )
V <sub>HC</sub> <sup>(3)</sup>	X	X	High-Z	Deselected — Standby (I <sub>SB1</sub> )

### NOTES:

2948 tbl 04

- H = V<sub>IH</sub>, L = V<sub>IL</sub>, x = Don't care.
- V<sub>LC</sub> = 0.2V, V<sub>HC</sub> = VCC - 0.2V.
- Other inputs ≥ V<sub>HC</sub> or ≤ V<sub>LC</sub>.

## RECOMMENDED DC OPERATING CONDITIONS

Symbol	Parameter	Min.	Typ.	Max.	Unit
VCC	Supply Voltage	4.5	5.0	5.5	V
GND	Supply Voltage	0	0	0	V
V <sub>IH</sub>	Input High Voltage	2.2	—	VCC+0.5	V
V <sub>IL</sub>	Input Low Voltage	-0.5 <sup>(1)</sup>	—	0.8	V

### NOTE:

2948 tbl 01

- V<sub>IL</sub> (min.) = -1.5V for pulse width less than 10ns, once per cycle.

## DC ELECTRICAL CHARACTERISTICS<sup>(1)</sup>

( $V_{CC} = 5.0V \pm 10\%$ ,  $V_{LC} = 0.2V$ ,  $V_{HC} = V_{CC} - 0.2V$ )

Symbol	Parameter	71256SA12 <sup>(3)</sup>	71256SA15	71256SA20	71256SA25 <sup>(3)</sup>	Unit
I <sub>CC</sub>	Dynamic Operating Current $\overline{CS} \leq V_{IL}$ , Outputs Open, $V_{CC} = \text{Max.}$ , $f = f_{\text{MAX}}^{(2)}$	160	150	145	145	mA
I <sub>SB</sub>	Standby Power Supply Current (TTL Level) $\overline{CS} \geq V_{IH}$ , Outputs Open, $V_{CC} = \text{Max.}$ , $f = f_{\text{MAX}}^{(2)}$	50	40	40	40	mA
I <sub>SB1</sub>	Standby Power Supply Current (CMOS Level) $\overline{CS} \geq V_{HC}$ , Outputs Open, $V_{CC} = \text{Max.}$ , $f = 0^{(2)}$ $V_{IN} \leq V_{LC}$ or $V_{IN} \geq V_{HC}$	15	15	15	15	mA

### NOTES:

- All values are maximum guaranteed values.
- $f_{\text{MAX}} = 1/t_{\text{RC}}$  (all address inputs are cycling at  $f_{\text{MAX}}$ );  $f = 0$  means no address input lines are changing.
- Commercial temperature range only.

2948 tbl 06

## AC TEST CONDITIONS

Input Pulse Levels	GND to 3.0V
Input Rise/Fall Times	3ns
Input Timing Reference Levels	1.5V
Output Reference Levels	1.5V
AC Test Load	See Figures 1 and 2

2948 tbl 07

## CAPACITANCE

( $T_A = +25^\circ\text{C}$ ,  $f = 1.0\text{MHz}$ , SOJ package)

Symbol	Parameter <sup>(1)</sup>	Conditions	Max.	Unit
C <sub>IN</sub>	Input Capacitance	$V_{IN} = 3\text{dV}$	7	pF
C <sub>I/O</sub>	I/O Capacitance	$V_{OUT} = 3\text{dV}$	7	pF

### NOTE:

- This parameter is guaranteed by device characterization, but not production tested.

2948 tbl 03

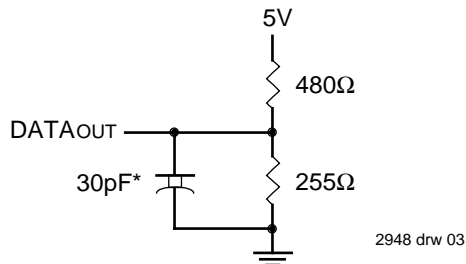

Figure 1. AC Test Load

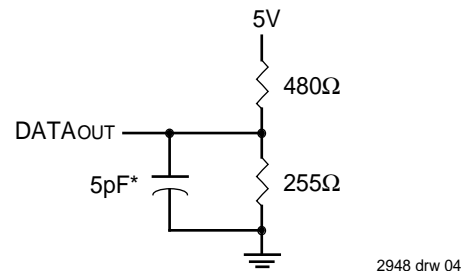

Figure 2. AC Test Load  
(for t<sub>CLZ</sub>, t<sub>OLZ</sub>, t<sub>CHZ</sub>, t<sub>OHZ</sub>, t<sub>OW</sub>, and t<sub>WHZ</sub>)

\*Including jig and scope capacitance.

**AC ELECTRICAL CHARACTERISTICS** ( $V_{CC} = 5.0V \pm 10\%$ )

Symbol	Parameter	71256SA12 <sup>(2)</sup>		71256SA15		71256SA20		71256SA25 <sup>(2)</sup>		
		Min.	Max.	Min.	Max.	Min.	Max.	Min.	Max.	
<b>Read Cycle</b>										
t <sub>RC</sub>	Read Cycle Time	12	—	15	—	20	—	25	—	ns
t <sub>AA</sub>	Address Access Time	—	12	—	15	—	20	—	25	ns
t <sub>ACS</sub>	Chip Select Access Time	—	12	—	15	—	20	—	25	ns
t <sub>CLZ</sub> <sup>(1)</sup>	Chip Select to Output in Low-Z	4	—	4	—	4	—	4	—	ns
t <sub>CHZ</sub> <sup>(1)</sup>	Chip Deselect to Output in High-Z	0	6	0	7	0	10	0	11	ns
t <sub>OE</sub>	Output Enable to Output Valid	—	6	—	7	—	10	—	11	ns
t <sub>OLZ</sub> <sup>(1)</sup>	Output Enable to Output in Low-Z	0	—	0	—	0	—	0	—	ns
t <sub>OHZ</sub> <sup>(1)</sup>	Output Disable to Output in High-Z	0	6	0	6	0	8	0	10	ns
t <sub>OH</sub>	Output Hold from Address Change	3	—	3	—	3	—	3	—	ns
t <sub>PU</sub> <sup>(1)</sup>	Chip Select to Power Up Time	0	—	0	—	0	—	0	—	ns
t <sub>PD</sub> <sup>(1)</sup>	Chip Deselect to Power Down Time	—	12	—	15	—	20	—	25	ns
<b>Write Cycle</b>										
t <sub>WC</sub>	Write Cycle Time	12	—	15	—	20	—	25	—	ns
t <sub>AW</sub>	Address Valid to End of Write	9	—	10	—	15	—	20	—	ns
t <sub>CW</sub>	Chip Select to End of Write	9	—	10	—	15	—	20	—	ns
t <sub>AS</sub>	Address Set-up Time	0	—	0	—	0	—	0	—	ns
t <sub>WP</sub>	Write Pulse Width	9	—	10	—	15	—	20	—	ns
t <sub>WR</sub>	Write Recovery Time	0	—	0	—	0	—	0	—	ns
t <sub>DW</sub>	Data Valid to End of Write	6	—	7	—	11	—	13	—	ns
t <sub>DH</sub>	Data Hold Time	0	—	0	—	0	—	0	—	ns
t <sub>OW</sub> <sup>(1)</sup>	Output Active from End of Write	4	—	4	—	4	—	4	—	ns
t <sub>WHZ</sub> <sup>(1)</sup>	Write Enable to Output in High-Z	0	6	0	6	0	10	0	11	ns

**NOTE:**

1. This parameter is guaranteed with the AC Load (Figure 2) by device characterization, but is not production tested.
2. Commercial temperature range only.

2948 tbl 08

**TIMING WAVEFORM OF READ CYCLE NO. 1<sup>(1)</sup>**

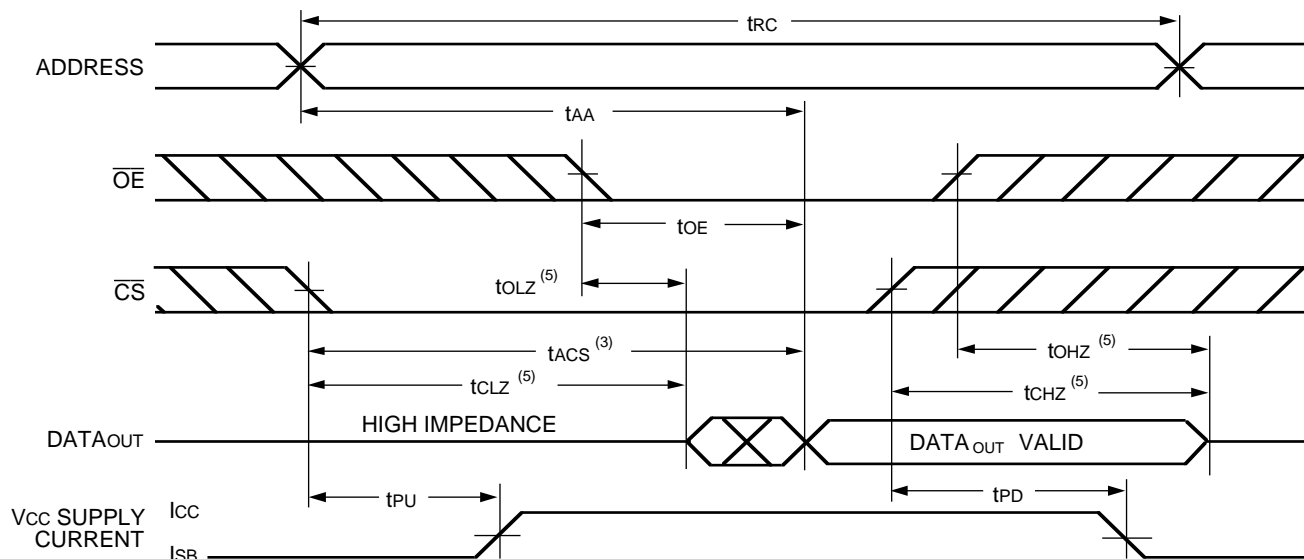

2948 drw 05

### TIMING WAVEFORM OF READ CYCLE NO. 2<sup>(1,2,4)</sup>

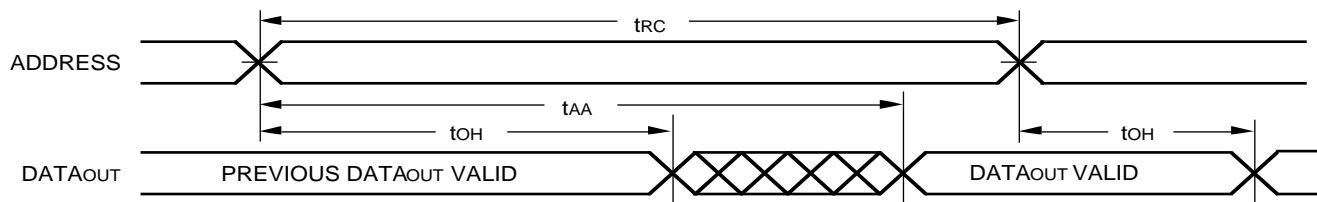

2948 drw 06

**NOTES:**

1.  $\overline{WE}$  is HIGH for Read Cycle.
2. Device is continuously selected,  $\overline{CS}$  is LOW.
3. Address must be valid prior to or coincident with the later of  $\overline{CS}$  transition LOW; otherwise  $t_{AA}$  is the limiting parameter.
4.  $\overline{OE}$  is LOW.
5. Transition is measured  $\pm 200\text{mV}$  from steady state.

### TIMING WAVEFORM OF WRITE CYCLE NO.1 ( $\overline{WE}$ CONTROLLED TIMING)<sup>(1,2,3,5)</sup>

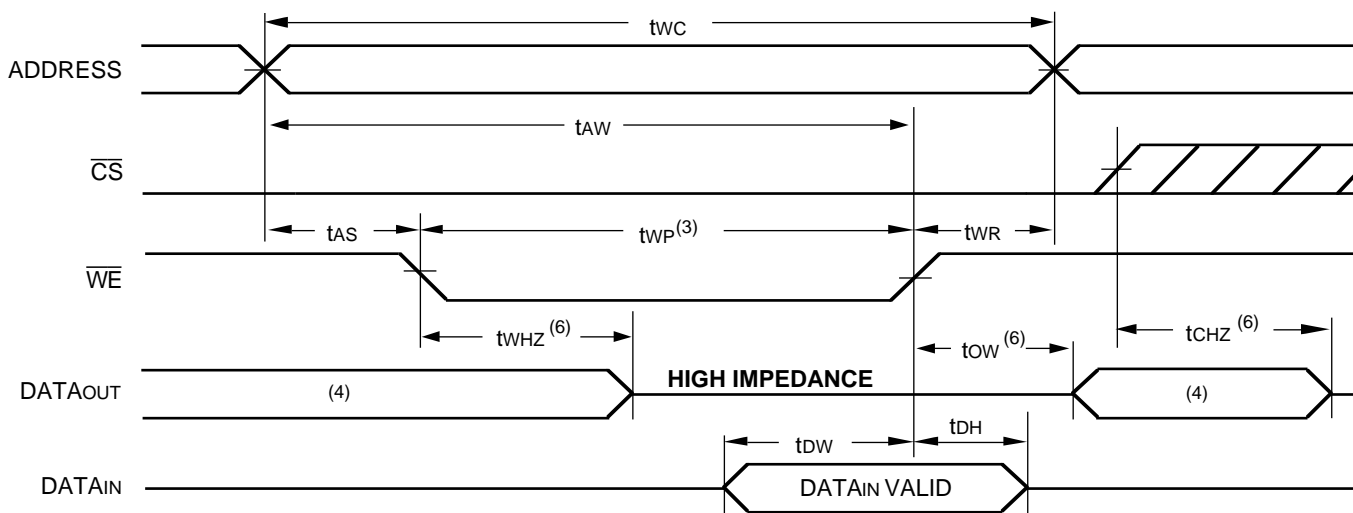

2948 drw 07

### TIMING WAVEFORM OF WRITE CYCLE NO.2 ( $\overline{CS}$ CONTROLLED TIMING)<sup>(1,2,5)</sup>

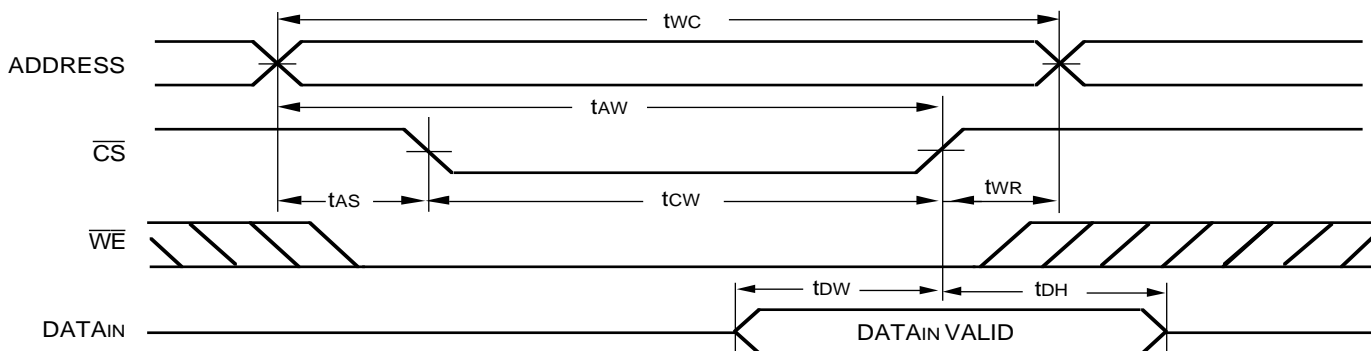

2948 drw 08

**NOTES:**

1.  $\overline{WE}$  or  $\overline{CS}$  must be HIGH during all address transitions.
2. A write occurs during the overlap of a LOW  $\overline{CS}$  and a LOW  $\overline{WE}$ .
3.  $\overline{OE}$  is continuously HIGH. If during a  $\overline{WE}$  controlled write cycle  $\overline{OE}$  is LOW,  $t_{WP}$  must be greater than or equal to  $t_{WHZ} + t_{DW}$  to allow the I/O drivers to turn off and data to be placed on the bus for the required  $t_{DW}$ . If  $\overline{OE}$  is HIGH during a  $\overline{WE}$  controlled write cycle, this requirement does not apply and the minimum write pulse is as short as the specified  $t_{WP}$ .
4. During this period, I/O pins are in the output state, and input signals must not be applied.
5. If the  $\overline{CS}$  LOW transition occurs simultaneously with or after the  $\overline{WE}$  LOW transition, the outputs remain in a high-impedance state.
6. Transition is measured  $\pm 200\text{mV}$  from steady state.

**ORDERING INFORMATION - COMMERCIAL**

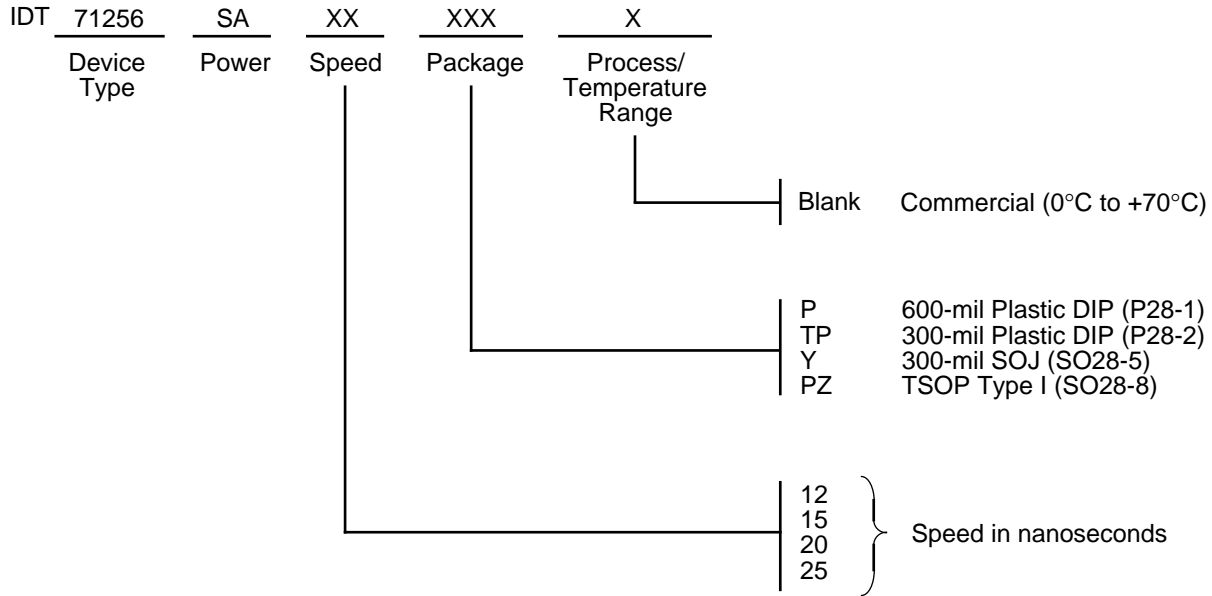

2948 drw 09

**ORDERING INFORMATION - INDUSTRIAL**

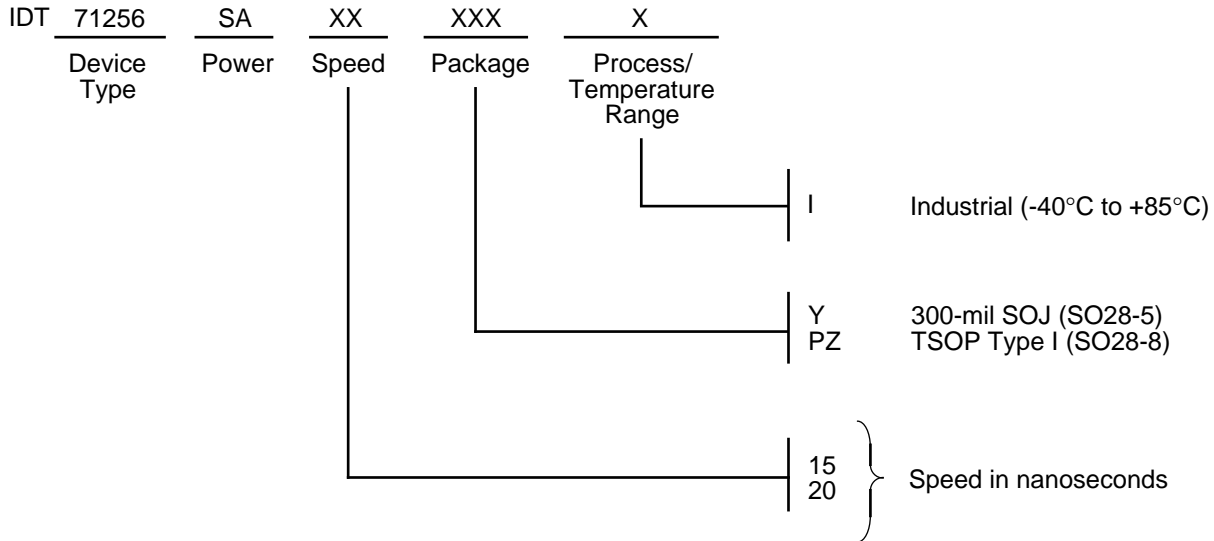

2948 drw 10

This datasheet has been downloaded from:

[www.DatasheetCatalog.com](http://www.DatasheetCatalog.com)

Datasheets for electronic components.



LittleDiode supplies new, hard to find or obsolete electronic components and semiconductors all over the world.

With over two million different components listed you are sure to find the part you need.

Feel free to visit us today at our online store:

[LittleDiode.com](http://LittleDiode.com)

Looking forward to providing you with the best possible service.