

Description

The IDT7130/IDT7140 are high-speed 1K x 8 Dual-Port Static RAMs. The IDT7130 is designed to be used as a stand-alone 8-bit Dual-Port RAM or as a "MASTER" Dual-Port RAM together with the IDT7140 "SLAVE" Dual-Port in 16-bit-or-more word width systems. Using the IDT MASTER/SLAVE Dual-Port RAM approach in 16-or-more-bit memory system applications results in full-speed, error-free operation without the need for additional discrete logic.

Both devices provide two independent ports with separate control, address, and I/O pins that permit independent asynchronous access for reads or writes to any location in memory. An automatic power down feature, controlled by \overline{CE} , permits the on chip circuitry

of each port to enter a very low standby power mode.

Fabricated using IDT's CMOS high-performance technology, these devices typically operate on only 550mW of power. Low-power (LA) versions offer battery backup data retention capability, with each Dual-Port typically consuming 200µW from a 2V battery.

The IDT7130/IDT7140 devices are packaged in 48-pin sidebrazed or plastic DIPs, LCCs, flatpacks, 52-pin PLCC, and 64-pin TQFP and STQFP. Military grade products are manufactured in compliance with the latest revision of MIL-PRF-38535 QML, making it ideally suited to military temperature applications demanding the highest level of performance and reliability.

Pin Configurations^(1,2,3)

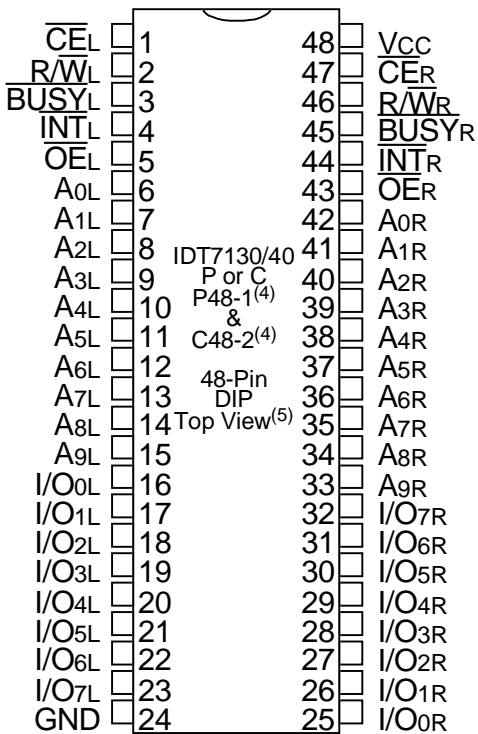

2689 drw 02

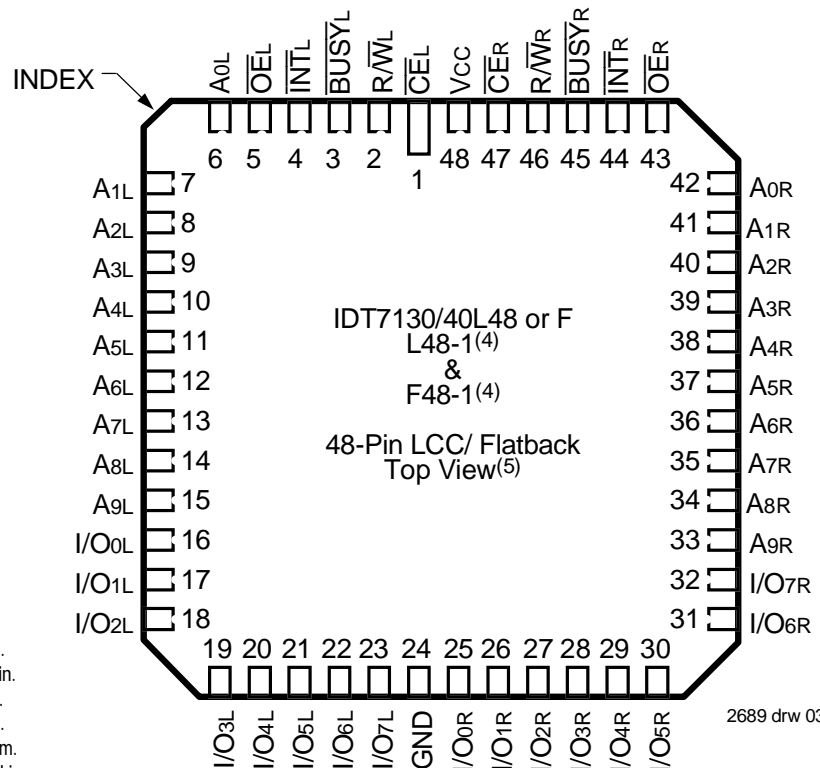

2689 drw 03

NOTES:

1. All V_{CC} pins must be connected to power supply.
2. All GND pins must be connected to ground supply.
3. P48-1 package body is approximately .55 in x .61 in x .19 in.
C48-2 package body is approximately .62 in x 2.43 in x .15 in.
L48-1 package body is approximately .57 in x .57 in x .68 in.
F48-1 package body is approximately .75 in x .75 in x .11 in.
4. This package code is used to reference the package diagram.
5. This text does not indicate orientation of the actual part-marking.

Pin Configurations^(1,2,3) (con't.)

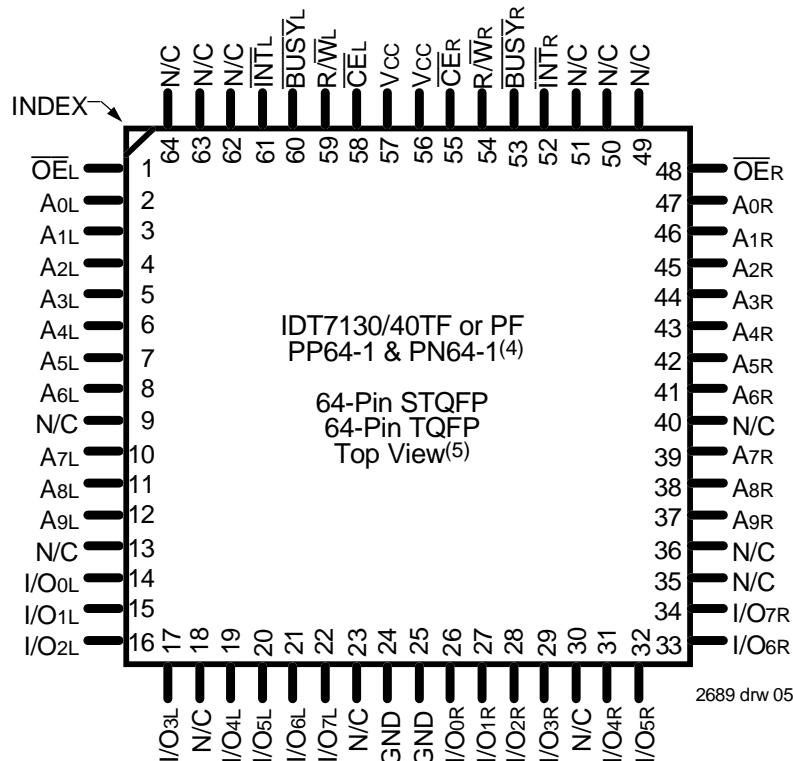
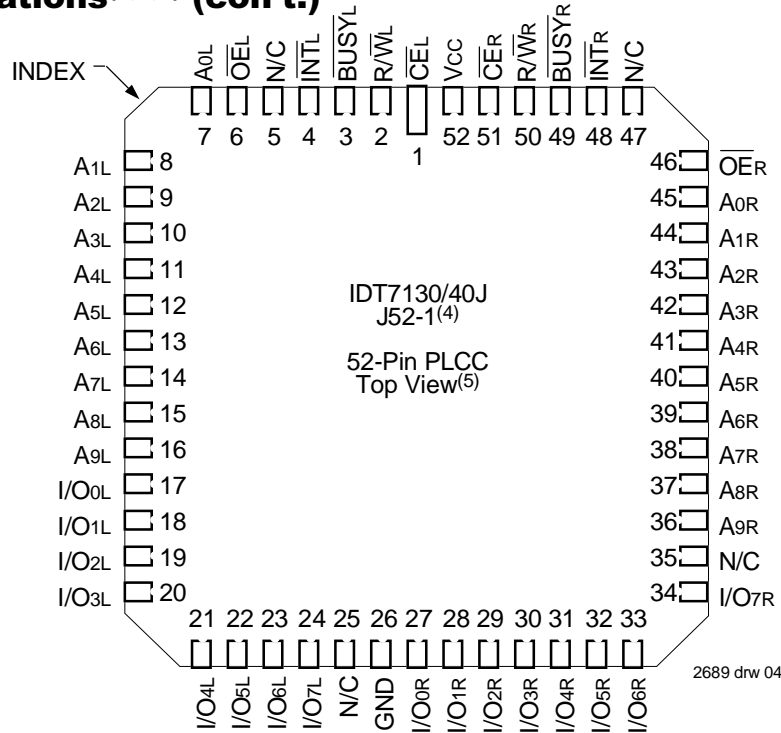

NOTES:

1. All Vcc pins must be connected to power supply.
2. All GND pins must be connected to ground supply.
3. J52-1 package body is approximately .75 in x .75 in x .17 in.
PP64-1 package body is approximately 10 mm x 10 mm x 1.4mm.
PN64-1 package body is approximately 14mm x 14mm x 1.4mm.
4. This package code is used to reference the package diagram.
5. This text does not indicate orientation of the actual part-marking.

Absolute Maximum Ratings⁽¹⁾

Symbol	Rating	Commercial & Industrial	Military	Unit
V _{TERM} ⁽²⁾	Terminal Voltage with Respect to GND	-0.5 to +7.0	-0.5 to +7.0	V
T _{BIAS}	Temperature Under Bias	-55 to +125	-65 to +135	°C
T _{STG}	Storage Temperature	-65 to +150	-65 to +150	°C
I _{OUT}	DC Output Current	50	50	mA

2689 tbl 01

NOTES:

- Stresses greater than those listed under ABSOLUTE MAXIMUM RATINGS may cause permanent damage to the device. This is a stress rating only and functional operation of the device at these or any other conditions above those indicated in the operational sections of the specification is not implied. Exposure to absolute maximum rating conditions for extended periods may affect reliability.
- V_{TERM} must not exceed V_{CC} + 10% for more than 25% of the cycle time or 10ns maximum, and is limited to ≤ 20mA for the period of V_{TERM} ≥ V_{CC} + 10%.

Capacitance (T_A = +25°C, f = 1.0MHz)

STQFP and TQFP Packages Only

Symbol	Parameter ⁽¹⁾	Conditions	Max.	Unit
C _{IN}	Input Capacitance	V _{IN} = 3dV	9	pF
C _{OUT}	Output Capacitance	V _{OUT} = 3dV	10	pF

2689 tbl 05

NOTES:

- This parameter is determined by device characterization but is not production tested.
- 3dV references the interpolated capacitance when the input and output signals switch from 0V to 3V or from 3V to 0V.

Recommended DC Operating Conditions

Symbol	Parameter	Min.	Typ.	Max.	Unit
V _{CC}	Supply Voltage	4.5	5.0	5.5	V
GND	Ground	0	0	0	V
V _{IH}	Input High Voltage	2.2	—	6.0 ⁽²⁾	V
V _{IL}	Input Low Voltage	-0.5 ⁽¹⁾	—	0.8	V

2689 tbl 02

NOTES:

- V_{IL} (min.) ≥ -1.5V for pulse width less than 10ns.
- V_{TERM} must not exceed V_{CC} + 10%.

Recommended Operating Temperature and Supply Voltage^(1,2)

Grade	Ambient Temperature	GND	V _{CC}
Military	-55°C to +125°C	0V	5.0V ± 10%
Commercial	0°C to +70°C	0V	5.0V ± 10%
Industrial	-40°C to +85°C	0V	5.0V ± 10%

2689 tbl 03

NOTES:

- This is the parameter T_A. This is the "instant on" case temperature.
- Industrial temperature: for specific speeds, packages and powers contact your sales office.

DC Electrical Characteristics Over the Operating Temperature and Supply Voltage Range (V_{CC} = 5.0V ± 10%)

Symbol	Parameter	Test Conditions	7130SA 7140SA		7130LA 7140LA		Unit
			Min.	Max.	Min.	Max.	
I _{LI}	Input Leakage Current ⁽¹⁾	V _{CC} = 5.5V, V _{IN} = 0V to V _{CC}	—	10	—	5	μA
I _{LO}	Output Leakage Current ⁽¹⁾	V _{CC} = 5.5V, C _E = V _{IH} , V _{OUT} = 0V to V _{CC}	—	10	—	5	μA
V _{OL}	Output Low Voltage (I _{OO} -I _{OO7})	I _{OL} = 4mA	—	0.4	—	0.4	V
V _{OL}	Open Drain Output Low Voltage (BUSY, INT)	I _{OL} = 16mA	—	0.5	—	0.5	V
V _{OH}	Output High Voltage	I _{OH} = -4mA	2.4	—	2.4	—	V

2689 tbl 04

NOTE:

- At V_{CC} ≤ 2.0V leakages are undefined.

DC Electrical Characteristics Over the Operating Temperature and Supply Voltage Range^(1,5,7) (V_{CC} = 5.0V ± 10%)

Symbol	Parameter	Test Condition	Version		7130X20 ⁽²⁾ 7140X20 ⁽²⁾ Com'l Only		7130X25 7140X25 Com'l & Military		7130X35 7140X35 Com'l & Military		Unit
					Typ.	Max.	Typ.	Max.	Typ.	Max.	
I _{CC}	Dynamic Operating Current (Both Ports Active)	\overline{CE}_L and $\overline{CE}_R = V_{IL}$, Outputs Disabled $f = f_{MAX}^{(3)}$	COM'L	SA	110	250	110	220	110	165	mA
				LA	110	200	110	170	110	120	
I _{SB1}	Standby Current (Both Ports - TTL Level Inputs)	\overline{CE}_L and $\overline{CE}_R = V_{IH}$ $f = f_{MAX}^{(3)}$	COM'L	SA	30	65	30	65	25	65	mA
				LA	30	45	30	45	25	45	
I _{SB2}	Standby Current (One Port - TTL Level Inputs)	$\overline{CE}^A = V_{IL}$ and $\overline{CE}^B = V_{IH}^{(6)}$ Active Port Outputs Disabled, $f = f_{MAX}^{(3)}$	COM'L	SA	65	165	65	150	50	125	mA
				LA	65	125	65	115	50	90	
I _{SB3}	Full Standby Current (Both Ports - CMOS Level Inputs)	\overline{CE}_L and $\overline{CE}_R \geq V_{CC} - 0.2V$, $V_{IN} \geq V_{CC} - 0.2V$ or $V_{IN} \leq 0.2V$, $f = 0^{(4)}$	COM'L	SA	1.0	15	1.0	15	1.0	15	mA
				LA	0.2	5	0.2	5	0.2	4	
I _{SB4}	Full Standby Current (One Port - CMOS Level Inputs)	$\overline{CE}^A \leq 0.2V$ and $\overline{CE}^B \geq V_{CC} - 0.2V^{(6)}$ $V_{IN} \geq V_{CC} - 0.2V$ or $V_{IN} \leq 0.2V$ Active Port Outputs Disabled, $f = f_{MAX}^{(3)}$	COM'L	SA	60	155	60	145	45	110	mA
				LA	60	115	60	105	45	85	
			MIL & IND	SA	—	—	110	280	110	230	
				LA	—	—	110	220	110	170	
			MIL & IND	SA	—	—	30	80	25	80	
				LA	—	—	30	60	25	60	
			MIL & IND	SA	—	—	65	160	50	150	
				LA	—	—	65	125	50	115	
			MIL & IND	SA	—	—	1.0	30	1.0	30	
				LA	—	—	0.2	10	0.2	10	
			MIL & IND	SA	—	—	60	155	45	145	
				LA	—	—	60	115	45	105	

2689 tbl 06a

Symbol	Parameter	Test Condition	Version		7130X55 7140X55 Com'l, Ind & Military		7130X100 7140X100 Com'l, Ind & Military		Unit
					Typ.	Max.	Typ.	Max.	
I _{CC}	Dynamic Operating Current (Both Ports Active)	\overline{CE}_L and $\overline{CE}_R = V_{IL}$, Outputs Disabled $f = f_{MAX}^{(3)}$	COM'L	SA	110	155	110	155	mA
				LA	110	110	110	110	
I _{SB1}	Standby Current (Both Ports - TTL Level Inputs)	\overline{CE}_L and $\overline{CE}_R = V_{IH}$ $f = f_{MAX}^{(3)}$	COM'L	SA	20	65	20	55	mA
				LA	20	35	20	35	
I _{SB2}	Standby Current (One Port - TTL Level Inputs)	$\overline{CE}^A = V_{IL}$ and $\overline{CE}^B = V_{IH}^{(6)}$ Active Port Outputs Disabled, $f = f_{MAX}^{(3)}$	COM'L	SA	40	110	40	110	mA
				LA	40	75	40	75	
I _{SB3}	Full Standby Current (Both Ports - CMOS Level Inputs)	\overline{CE}_L and $\overline{CE}_R \geq V_{CC} - 0.2V$, $V_{IN} \geq V_{CC} - 0.2V$ or $V_{IN} \leq 0.2V$, $f = 0^{(4)}$	COM'L	SA	1.0	15	1.0	15	mA
				LA	0.2	4	0.2	4	
I _{SB4}	Full Standby Current (One Port - CMOS Level Inputs)	$\overline{CE}^A \leq 0.2V$ and $\overline{CE}^B \geq V_{CC} - 0.2V^{(6)}$ $V_{IN} \geq V_{CC} - 0.2V$ or $V_{IN} \leq 0.2V$ Active Port Outputs Disabled, $f = f_{MAX}^{(3)}$	COM'L	SA	40	100	40	95	mA
				LA	40	70	40	70	
			MIL & IND	SA	110	190	110	190	
				LA	110	140	110	140	
			MIL & IND	SA	20	65	20	65	
				LA	20	45	20	45	
			MIL & IND	SA	40	125	40	125	
				LA	40	90	40	90	
			MIL & IND	SA	1.0	30	1.0	30	
				LA	0.2	10	0.2	10	
			MIL & IND	SA	40	100	40	95	
				LA	40	70	40	70	
			MIL & IND	SA	40	110	40	110	
				LA	40	85	40	80	

2689 tbl 06b

NOTES:

- 'X' in part numbers indicates power rating (SA or LA).
- PLCC and TQFP packages only.
- At $f = f_{MAX}$, address and control lines (except Output Enable) are cycling at the maximum frequency read cycle of $1/t_{cvc}$, and using "AC TEST CONDITIONS" of input levels of GND to 3V.
- $f = 0$ means no address or control lines change. Applies only to inputs at CMOS level standby.
- V_{CC} = 5V, T_A = +25°C for Typ and is not production tested. V_{CC} DC = 100 mA (Typ)
- Port "A" may be either left or right port. Port "B" is opposite from port "A".
- Industrial temperature: for other speeds, packages and powers contact your sales office.

Data Retention Characteristics (LA Version Only)

Symbol	Parameter	Test Condition	7130LA/7140LA			Unit	
			Min.	Typ. ⁽¹⁾	Max.		
V _{DR}	V _{CC} for Data Retention	V _{CC} = 2.0V, $\overline{CE} \geq V_{CC} - 0.2V$	2.0	—	—	V	
I _{CCDR}	Data Retention Current		MIL. & IND.	—	100	4000	μA
			COM'L.	—	100	1500	
t _{CDR} ⁽³⁾	Chip Deselect to Data Retention Time	V _{IN} ≥ V _{CC} - 0.2V or V _{IN} ≤ 0.2V	0	—	—	ns	
t _R ⁽³⁾	Operation Recovery Time		t _{RC} ⁽²⁾	—	—	ns	

2689 tb1 07

NOTES:

1. V_{CC} = 2V, T_A = +25°C, and is not production tested.
2. t_{RC} = Read Cycle Time
3. This parameter is guaranteed but not production tested.

Data Retention Waveform

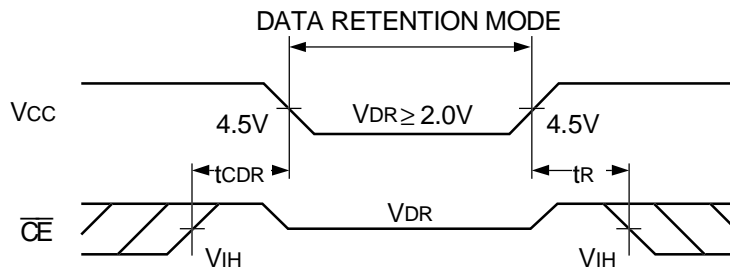

2692 drw 06

AC Test Conditions

Input Pulse Levels	GND to 3.0V
Input Rise/Fall Times	5ns
Input Timing Reference Levels	1.5V
Output Reference Levels	1.5V
Output Load	Figures 1,2 and 3

2689 bl 08

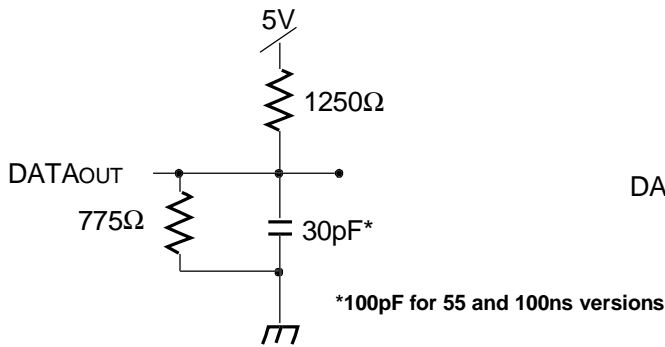

Figure 1. Output Test Load

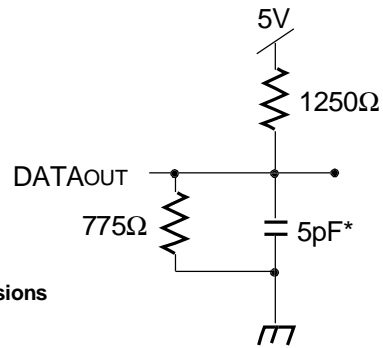

Figure 2. Output Test Load
(for t_{HZ}, t_{LZ}, t_{wz}, and t_{ow})
* including scope and jig

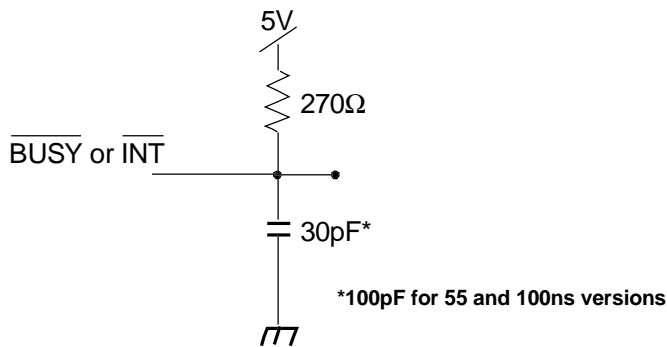

Figure 3. $\overline{\text{BUSY}}$ and $\overline{\text{INT}}$
AC Output Test Load

2689 drw 07

AC Electrical Characteristics Over the Operating Temperature Supply Voltage Range^(3,5)

Symbol	Parameter	7130X20 ⁽²⁾ 7140X20 ⁽²⁾ Com'l Only		7130X25 7140X25 Com'l & Military		7130X35 7140X35 Com'l & Military		Unit
		Min.	Max.	Min.	Max.	Min.	Max.	
READ CYCLE								
t _{RC}	Read Cycle Time	20	—	25	—	35	—	ns
t _{AA}	Address Access Time	—	20	—	25	—	35	ns
t _{ACE}	Chip Enable Access Time	—	20	—	25	—	35	ns
t _{AOE}	Output Enable Access Time	—	11	—	12	—	20	ns
t _{OH}	Output Hold from Address Change	3	—	3	—	3	—	ns
t _{LZ}	Output Low-Z Time ^(1,4)	0	—	0	—	0	—	ns
t _{HZ}	Output High-Z Time ^(1,4)	—	10	—	10	—	15	ns
t _{PU}	Chip Enable to Power Up Time ⁽⁴⁾	0	—	0	—	0	—	ns
t _{PD}	Chip Disable to Power Down Time ⁽⁴⁾	—	20	—	25	—	35	ns

2689 tbl 09a

Symbol	Parameter	7130X55 7140X55 Com'l, Ind & Military		7130X100 7140X100 Com'l, Ind & Military		Unit
		Min.	Max.	Min.	Max.	
READ CYCLE						
t _{RC}	Read Cycle Time	55	—	100	—	ns
t _{AA}	Address Access Time	—	55	—	100	ns
t _{ACE}	Chip Enable Access Time	—	55	—	100	ns
t _{AOE}	Output Enable Access Time	—	25	—	40	ns
t _{OH}	Output Hold from Address Change	3	—	10	—	ns
t _{LZ}	Output Low-Z Time ^(1,4)	5	—	5	—	ns
t _{HZ}	Output High-Z Time ^(1,4)	—	25	—	40	ns
t _{PU}	Chip Enable to Power Up Time ⁽⁴⁾	0	—	0	—	ns
t _{PD}	Chip Disable to Power Down Time ⁽⁴⁾	—	50	—	50	ns

2689 tbl 09b

NOTES:

1. Transition is measured 0mV from Low or High-impedance voltage Output Test Load (Figure 2).
2. PLCC, TQFP and STQFP packages only.
3. 'X' in part numbers indicates power rating (SA or LA).
4. This parameter is guaranteed by device characterization, but is not production tested.
5. Industrial temperature: for other speeds, packages and powers contact your sales office.

Timing Waveform of Read Cycle No. 1, Either Side⁽¹⁾

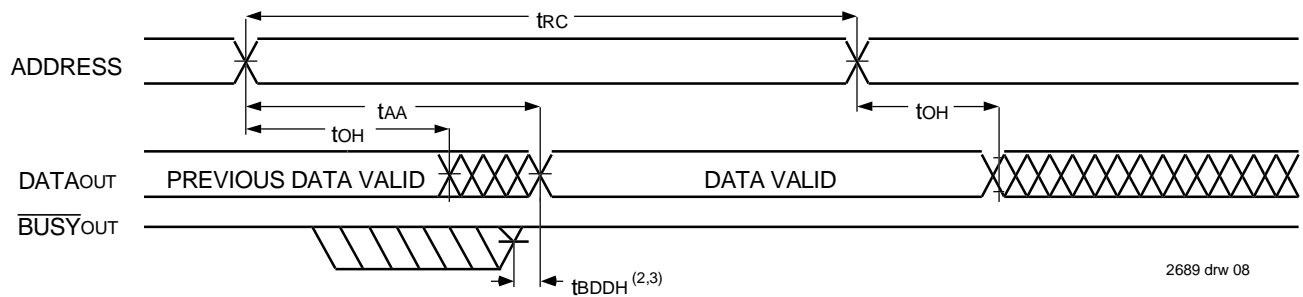

NOTES:

1. $R/\bar{W} = V_{IH}$, $\bar{CE} = V_{IL}$, and is $\bar{OE} = V_{IL}$. Address is valid prior to the coincidental with \bar{CE} transition LOW.
2. t_{BDH} delay is required only in the case where the opposite port is completing a write operation to the same the address location. For simultaneous read operations, \bar{BUSY} has no relationship to valid output data.
3. Start of valid data depends on which timing becomes effective last t_{AOE} , t_{ACE} , t_{AA} , and t_{BDD} .

Timing Waveform of Read Cycle No. 2, Either Side⁽³⁾

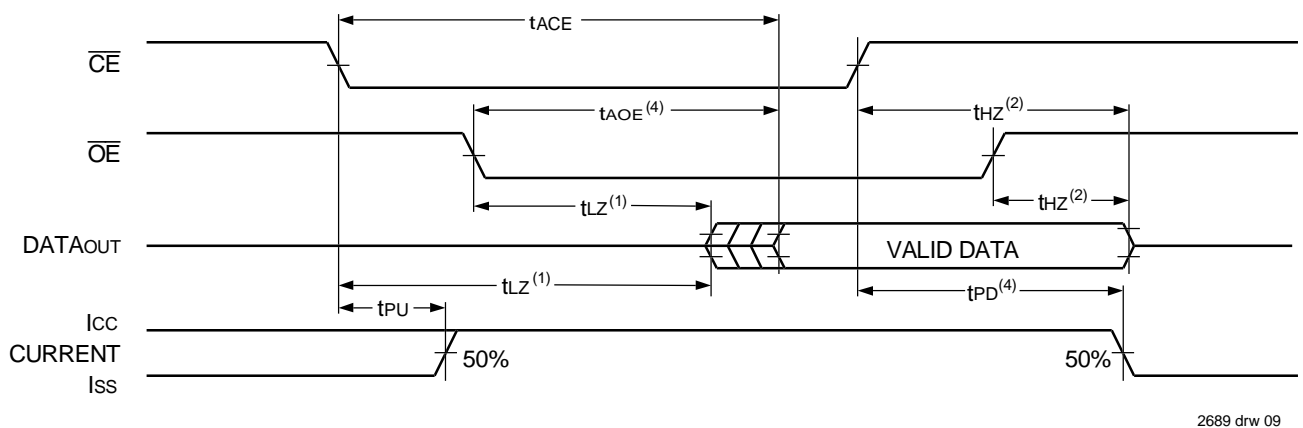

NOTES:

1. Timing depends on which signal is asserted last, \bar{OE} or \bar{CE} .
2. Timing depends on which signal is deasserted first, \bar{OE} or \bar{CE} .
3. $R/\bar{W} = V_{IH}$ and $\bar{OE} = V_{IL}$, and the address is valid prior to or coincidental with \bar{CE} transition LOW.
4. Start of valid data depends on which timing becomes effective last t_{AOE} , t_{ACE} , t_{AA} , and t_{BDD} .

AC Electrical Characteristics Over the Operating Temperature Supply Voltage Range^(5,6)

Symbol	Parameter	7130X20 ⁽²⁾ 7140X20 ⁽²⁾ Com'l Only		7130X25 7140X25 Com'l & Military		7130X35 7140X35 Com'l & Military		Unit
		Min.	Max.	Min.	Max.	Min.	Max.	
WRITE CYCLE								
t _{WC}	Write Cycle Time ⁽³⁾	20	—	25	—	35	—	ns
t _{EW}	Chip Enable to End-of-Write	15	—	20	—	30	—	ns
t _{AW}	Address Valid to End-of-Write	15	—	20	—	30	—	ns
t _{AS}	Address Set-up Time	0	—	0	—	0	—	ns
t _{WP}	Write Pulse Width ⁽⁴⁾	15	—	15	—	25	—	ns
t _{WR}	Write Recovery Time	0	—	0	—	0	—	ns
t _{DW}	Data Valid to End-of-Write	10	—	12	—	15	—	ns
t _{HZ}	Output High-Z Time ⁽¹⁾	—	10	—	10	—	15	ns
t _{DH}	Data Hold Time	0	—	0	—	0	—	ns
t _{WZ}	Write Enable to Output in High-Z ⁽¹⁾	—	10	—	10	—	15	ns
t _{OW}	Output Active from End-of-Write ⁽¹⁾	0	—	0	—	0	—	ns

2689 tbl 10a

Symbol	Parameter	7130X55 7140X55 Com'l, Ind & Military		7130X100 7140X100 Com'l, Ind & Military		Unit
		Min.	Max.	Min.	Max.	
WRITE CYCLE						
t _{WC}	Write Cycle Time ⁽³⁾	55	—	100	—	ns
t _{EW}	Chip Enable to End-of-Write	40	—	90	—	ns
t _{AW}	Address Valid to End-of-Write	40	—	90	—	ns
t _{AS}	Address Set-up Time	0	—	0	—	ns
t _{WP}	Write Pulse Width ⁽⁴⁾	30	—	55	—	ns
t _{WR}	Write Recovery Time	0	—	0	—	ns
t _{DW}	Data Valid to End-of-Write	20	—	40	—	ns
t _{HZ}	Output High-Z Time ⁽¹⁾	—	25	—	40	ns
t _{DH}	Data Hold Time	0	—	0	—	ns
t _{WZ}	Write Enable to Output in High-Z ⁽¹⁾	—	25	—	40	ns
t _{OW}	Output Active from End-of-Write ⁽¹⁾	0	—	0	—	ns

2689 tbl 10b

NOTES:

- Transition is measured 0mV from Low or High-impedance voltage with Output Test Load (Figure 2). This parameter is guaranteed by device characterization but is not production tested.
- PLCC, TQFP and STQFP packages only.
- For MASTER/SLAVE combination, t_{WC} = t_{BAA} + t_{WP}, since R \bar{W} = V_{IL} must occur after t_{BAA}.
- If $\bar{O}E$ is LOW during a R \bar{W} controlled write cycle, the write pulse width must be the larger of t_{WP} or (t_{WZ} + t_{DW}) to allow the I/O drivers to turn off data to be placed on the bus for the required t_{DW}. If $\bar{O}E$ is HIGH during a R \bar{W} controlled write cycle, this requirement does not apply and the write pulse can be as short as the specified t_{WP}.
- 'X' in part numbers indicates power rating (SA or LA).
- Industrial temperature: for other speeds, packages and powers contact your sales office.

Timing Waveform of Write Cycle No. 1, ($\overline{R/\overline{W}}$ Controlled Timing)^(1,5,8)

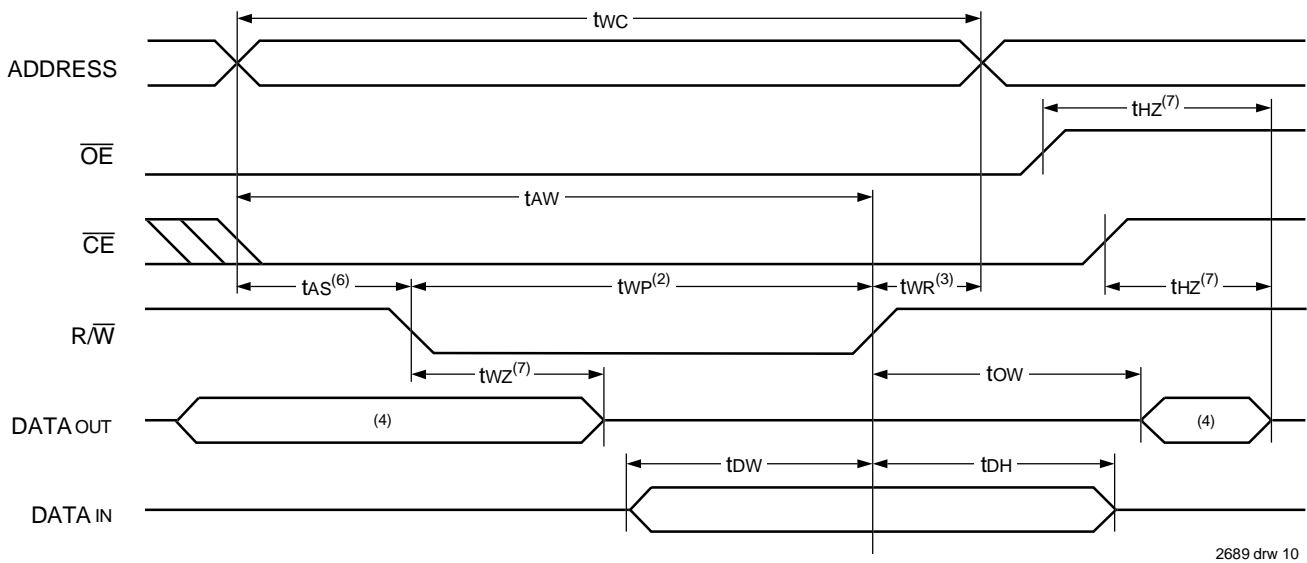

Timing Waveform of Write Cycle No. 2, (\overline{CE} Controlled Timing)^(1,5)

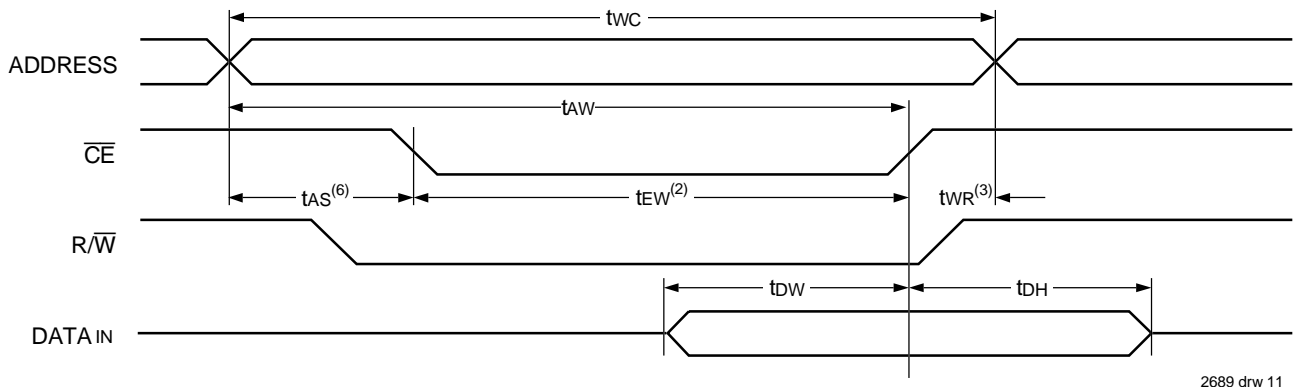

NOTES:

1. $\overline{R/\overline{W}}$ or \overline{CE} must be HIGH during all address transitions.
2. A write occurs during the overlap (t_{EW} or t_{WP}) of $\overline{CE} = V_{IL}$ and $\overline{R/\overline{W}} = V_{IL}$.
3. t_{WR} is measured from the earlier of \overline{CE} or $\overline{R/\overline{W}}$ going HIGH to the end of the write cycle.
4. During this period, the I/O pins are in the output state and input signals must not be applied.
5. If the \overline{CE} LOW transition occurs simultaneously with or after the $\overline{R/\overline{W}}$ LOW transition, the outputs remain in the HIGH impedance state.
6. Timing depends on which enable signal (\overline{CE} or $\overline{R/\overline{W}}$) is asserted last.
7. This parameter is determined by device characterization, but is not production tested. Transition is measured 0mV from steady state with the Output Test Load (Figure 2).
8. If \overline{OE} is LOW during a $\overline{R/\overline{W}}$ controlled write cycle, the write pulse width must be the larger of t_{WP} or $(t_{WZ} + t_{DW})$ to allow the I/O drivers to turn off data to be placed on the bus for the required t_{DW} . If \overline{OE} is HIGH during a $\overline{R/\overline{W}}$ controlled write cycle, this requirement does not apply and the write pulse can be as short as the specified t_{WP} .

AC Electrical Characteristics Over the Operating Temperature and Supply Voltage Range^(7,9)

Symbol	Parameter	7130X20 ⁽¹⁾ 7140X20 ⁽¹⁾ Com'l Only		7130X25 7140X25 Com'l & Military		7130X35 7140X35 Com'l & Military		Unit
		Min.	Max.	Min.	Max.	Min.	Max.	
BUS\bar{Y} TIMING (For MASTER IDT 7130)								
tBAA	BUS \bar{Y} Access Time from Address	—	20	—	20	—	20	ns
tBDA	BUS \bar{Y} Disable Time from Address	—	20	—	20	—	20	ns
tBAC	BUS \bar{Y} Access Time from Chip Enable	—	20	—	20	—	20	ns
tBDC	BUS \bar{Y} Disable Time from Chip Enable	—	20	—	20	—	20	ns
tWH	Write Hold After BUS \bar{Y} ⁽⁶⁾	12	—	15	—	20	—	ns
tWDD	Write Pulse to Data Delay ⁽²⁾	—	40	—	50	—	60	ns
tDDD	Write Data Valid to Read Data Delay ⁽²⁾	—	30	—	35	—	35	ns
tAPS	Arbitration Priority Set-up Time ⁽³⁾	5	—	5	—	5	—	ns
tBDD	BUS \bar{Y} Disable to Valid Data ⁽⁴⁾	—	25	—	35	—	35	ns
BUS\bar{Y} INPUT TIMING (For SLAVE IDT 7140)								
tWB	Write to BUS \bar{Y} Input ⁽⁵⁾	0	—	0	—	0	—	ns
tWH	Write Hold After BUS \bar{Y} ⁽⁶⁾	12	—	15	—	20	—	ns
tWDD	Write Pulse to Data Delay ⁽²⁾	—	40	—	50	—	60	ns
tDDD	Write Data Valid to Read Data Delay ⁽²⁾	—	30	—	35	—	35	ns

2689 tbl 11a

Symbol	Parameter	7130X55 7140X55 Com'l, Ind & Military		7130X100 7140X100 Com'l, Ind & Military		Unit
		Min.	Max.	Min.	Max.	
BUS\bar{Y} TIMING (For MASTER IDT 7130)						
tBAA	BUS \bar{Y} Access Time from Address]	—	30	—	50	ns
tBDA	BUS \bar{Y} Disable Time from Address	—	30	—	50	ns
tBAC	BUS \bar{Y} Access Time from Chip Enable	—	30	—	50	ns
tBDC	BUS \bar{Y} Disable Time from Chip Enable	—	30	—	50	ns
tWH	Write Hold After BUS \bar{Y} ⁽⁶⁾	20	—	20	—	ns
tWDD	Write Pulse to Data Delay ⁽²⁾	—	80	—	120	ns
tDDD	Write Data Valid to Read Data Delay ⁽²⁾	—	55	—	100	ns
tAPS	Arbitration Priority Set-up Time ⁽³⁾	5	—	5	—	ns
tBDD	BUS \bar{Y} Disable to Valid Data ⁽⁴⁾	—	55	—	65	ns
BUS\bar{Y} INPUT TIMING (For SLAVE IDT 7140)						
tWB	Write to BUS \bar{Y} Input ⁽⁵⁾	0	—	0	—	ns
tWH	Write Hold After BUS \bar{Y} ⁽⁶⁾	20	—	20	—	ns
tWDD	Write Pulse to Data Delay ⁽²⁾	—	80	—	120	ns
tDDD	Write Data Valid to Read Data Delay ⁽²⁾	—	55	—	100	ns

2689 tbl 11b

NOTES:

1. PLCC, TOFP and STQFP packages only.
2. Port-to-port delay through RAM cells from the writing port to the reading port, refer to "Timing Waveform of Write with Port -to-Port Read and BUS \bar{Y} ."
3. To ensure that the earlier of the two ports wins.
4. tBDD is a calculated parameter and is the greater of 0, tWDD – tWP (actual) or tDDD – tDW (actual).
5. To ensure that a write cycle is inhibited on port 'B' during contention on port 'A'.
6. To ensure that a write cycle is completed on port 'B' after contention on port 'A'.
7. 'X' in part numbers indicates power rating (S or L).
8. Industrial temperature: for other speeds, packages and powers contact your sales office.

Timing Waveform of Write with Port-to-Port Read and $\overline{\text{BUSY}}^{(2,3,4)}$

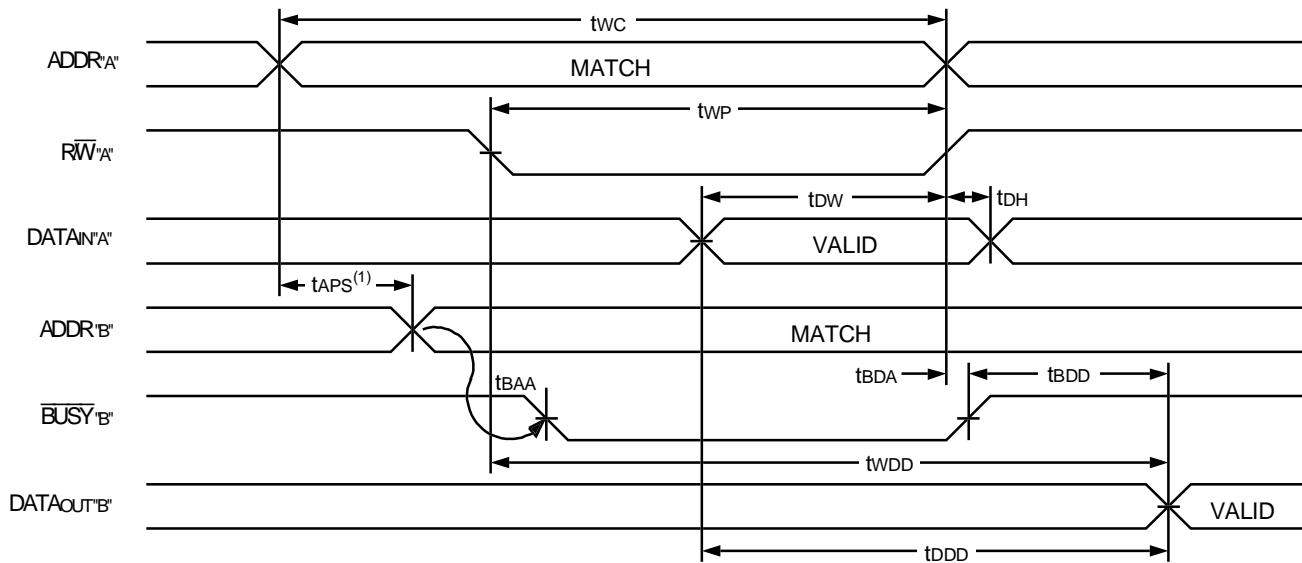

2689 drw 12

NOTES:

1. To ensure that the earlier of the two ports wins. t_{BDD} is ignored for slave (IDT7140).
2. $\overline{\text{CE}}_L = \overline{\text{CE}}_R = V_{IL}$
3. $\overline{\text{OE}} = V_{IL}$ for the reading port.
4. All timing is the same for the left and right ports. Port 'A' may be either the left or right port. Port 'B' is opposite from port 'A'.

Timing Waveform of Write with $\overline{\text{BUSY}}^{(3)}$

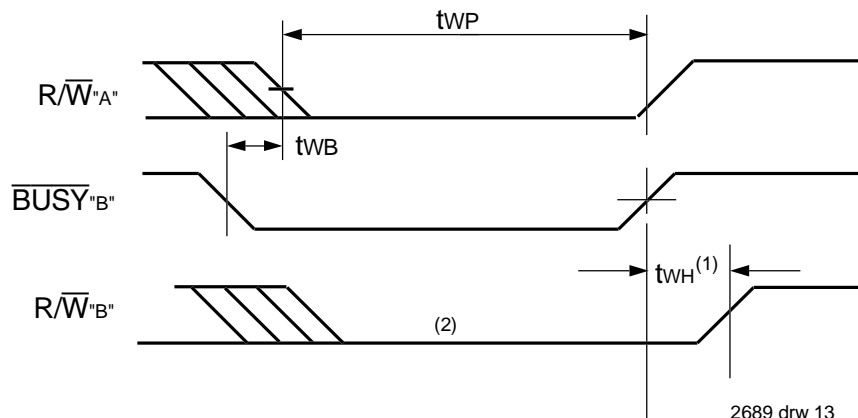

2689 drw 13

NOTES:

1. t_{WH} must be met for both $\overline{\text{BUSY}}$ Input (IDT7140, slave) or Output (IDT7130 master).
2. $\overline{\text{BUSY}}$ is asserted on port 'B' blocking $\overline{\text{R/W}}^B$, until $\overline{\text{BUSY}}^B$ goes HIGH.
3. All timing is the same for the left and right ports. Port 'A' may be either the left or right port. Port 'B' is opposite from port 'A'.

Timing Waveform of $\overline{\text{BUSY}}$ Arbitration Controlled by $\overline{\text{CE}}$ Timing⁽¹⁾

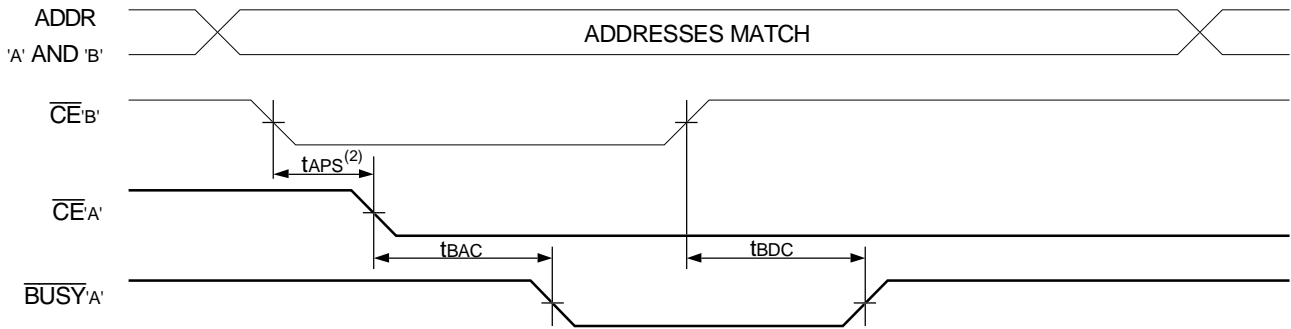

2689 drw 14

Timing Waveform by $\overline{\text{BUSY}}$ Arbitration Controlled by Address Match Timing⁽¹⁾

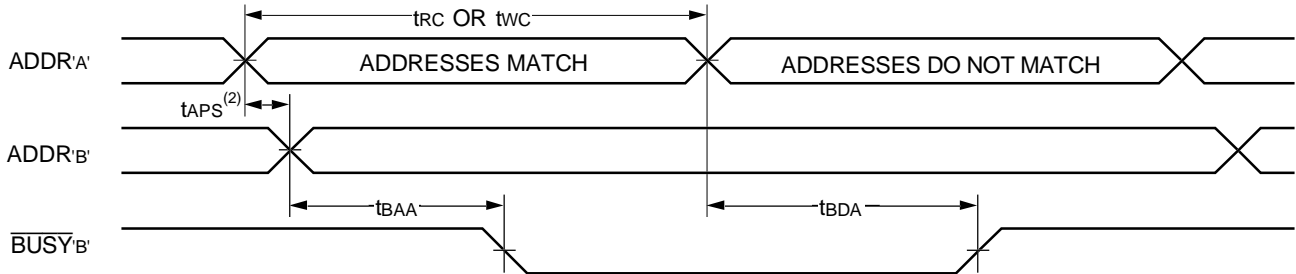

2689 drw 15

NOTES:

1. All timing is the same for left and right ports. Port "A" may be either left or right port. Port "B" is the opposite from port "A".
2. If tAPS is not satisfied, the $\overline{\text{BUSY}}$ will be asserted on one side or the other, but there is no guarantee on which side $\overline{\text{BUSY}}$ will be asserted (7130 only).

AC Electrical Characteristics Over the Operating Temperature and Supply Voltage Range^(2,3)

Symbol	Parameter	7130X20 ⁽¹⁾ 7140X20 ⁽¹⁾ Com'l Only		7130X25 7140X25 Com'l & Military		7130X35 7140X35 Com'l & Military		Unit
		Min.	Max.	Min.	Max.	Min.	Max.	
INTERRUPT TIMING								
tAS	Address Set-up Time	0	—	0	—	0	—	ns
tWR	Write Recovery Time	0	—	0	—	0	—	ns
tINS	Interrupt Set Time	—	20	—	25	—	25	ns
tINR	Interrupt Reset Time	—	20	—	25	—	25	ns

2689 tbl 12a

NOTES:

1. PLCC, TOFP and STQFP package only.
2. 'X' in part numbers indicates power rating (SA or LA).
3. Industrial temperature: for other speeds, packages and powers contact your sales office.

AC Electrical characteristics Over the Operating Temperature and Supply Voltage Range^(1,2)

Symbol	Parameter	7130X55 7140X55 Com'l, Ind & Military		7130X100 7140X100 Com'l, Ind & Military		Unit
		Min.	Max.	Min.	Max.	
INTERRUPT TIMING						
t _{AS}	Address Set-up Time	0	—	0	—	ns
t _{WR}	Write Recovery Time	0	—	0	—	ns
t _{INS}	Interrupt Set Time	—	45	—	60	ns
t _{INR}	Interrupt Reset Time	—	45	—	60	ns

2689 tbl 12b

NOTES:

- 'X' in part numbers indicates power rating (SA or LA).
- Industrial temperature: for other speeds, packages and powers contact your sales office.

Timing Waveform of Interrupt Mode⁽¹⁾

$\overline{\text{INT}}$ Set:

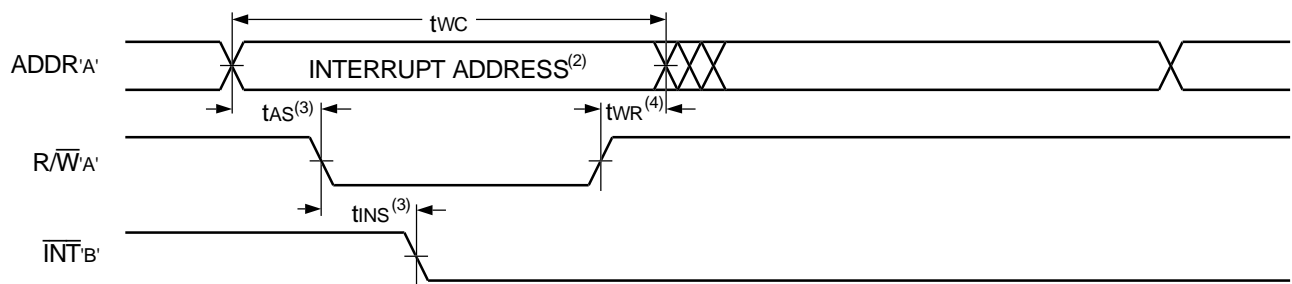

2689 drw 16

$\overline{\text{INT}}$ Clear:

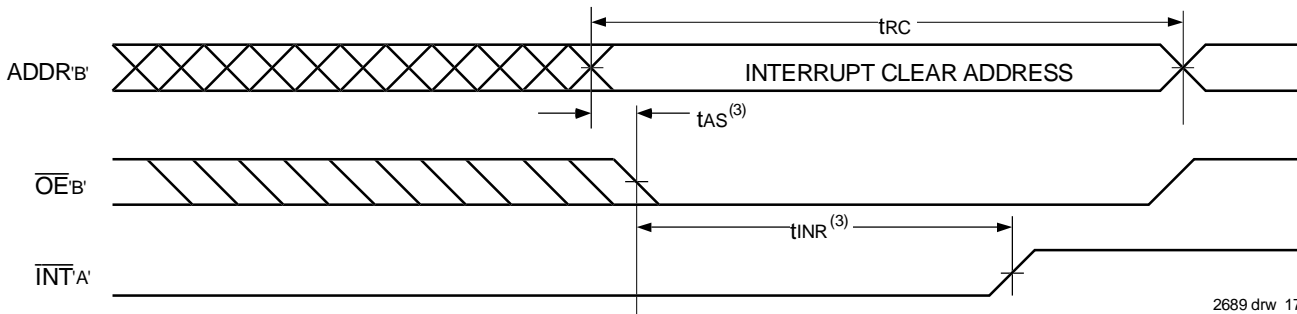

2689 drw 17

NOTES:

- All timing is the same for left and right ports. Port "A" may be either left or right port. Port "B" is the opposite from port "A".
- See Interrupt Truth Table II.
- Timing depends on which enable signal ($\overline{\text{CE}}$ or $\overline{\text{R/W}}$) is asserted last.
- Timing depends on which enable signal ($\overline{\text{CE}}$ or $\overline{\text{R/W}}$) is de-asserted first.

Truth Tables

Truth Table I — Non-Contention Read/Write Control⁽⁴⁾

Inputs ⁽¹⁾				Function
R/W	CE	OE	D0-7	
X	H	X	Z	Port Disabled and in Power-Down Mode, ISB2 or ISB4
X	H	X	Z	$\overline{CE}_R = \overline{CE}_L = V_{IH}$, Power-Down Mode, ISB1 or ISB3
L	L	X	DATA _{IN}	Data on Port Written into Memory ⁽²⁾
H	L	L	DATA _{OUT}	Data in Memory Output on Port ⁽³⁾
H	L	H	Z	High Impedance Outputs

2689 tbl 13

NOTES:

- A0L – A10L • A0R – A10R.
- If $\overline{BUSY} = L$, data is not written.
- If $\overline{BUSY} = L$, data may not be valid, see t_{WDD} and t_{DD} timing.
- 'H' = V_{IH} , 'L' = V_{IL} , 'X' = DON'T CARE, 'Z' = HIGH IMPEDANCE

Truth Table II — Interrupt Flag^(1,4)

Left Port					Right Port					Function
R/WL	CEL	OEL	A9L-A0L	INTL	RWR	CEr	OEr	A9R-A0R	INTR	
L	L	X	3FF	X	X	X	X	X	L ⁽²⁾	Set Right \overline{INTR} Flag
X	X	X	X	X	X	L	L	3FF	H ⁽³⁾	Reset Right \overline{INTR} Flag
X	X	X	X	L ⁽³⁾	L	L	X	3FE	X	Set Left \overline{INTL} Flag
X	L	L	3FE	H ⁽²⁾	X	X	X	X	X	Reset Left \overline{INTL} Flag

2689 tbl 14

NOTES:

- Assumes $\overline{BUSYL} = \overline{BUSYR} = V_{IH}$
- If $\overline{BUSYL} = V_{IL}$, then No Change.
- If $\overline{BUSYR} = V_{IL}$, then No Change.
- 'H' = HIGH, 'L' = LOW, 'X' = DON'T CARE

Truth Table III — Address \overline{BUSY} Arbitration

Inputs			Outputs		Function
CEL	CEr	A0L-A9L A0R-A9R	$\overline{BUSYL}^{(1)}$	$\overline{BUSYR}^{(1)}$	
X	X	NO MATCH	H	H	Normal
H	X	MATCH	H	H	Normal
X	H	MATCH	H	H	Normal
L	L	MATCH	(2)	(2)	Write Inhibit ⁽³⁾

2689 tbl 15

NOTES:

- Pins \overline{BUSYL} and \overline{BUSYR} are both outputs for IDT7130 (master). Both are inputs for IDT7140 (slave). \overline{BUSYx} outputs on the IDT7130 are open drain, not push-pull outputs. On slaves the \overline{BUSYx} input internally inhibits writes.
- 'L' if the inputs to the opposite port were stable prior to the address and enable inputs of this port. 'H' if the inputs to the opposite port became stable after the address and enable inputs of this port. If t_{APS} is not met, either \overline{BUSYL} or $\overline{BUSYR} = LOW$ will result. \overline{BUSYL} and \overline{BUSYR} outputs can not be LOW simultaneously.
- Writes to the left port are internally ignored when \overline{BUSYL} outputs are driving LOW regardless of actual logic level on the pin. Writes to the right port are internally ignored when \overline{BUSYR} outputs are driving LOW regardless of actual logic level on the pin.

Ordering Information

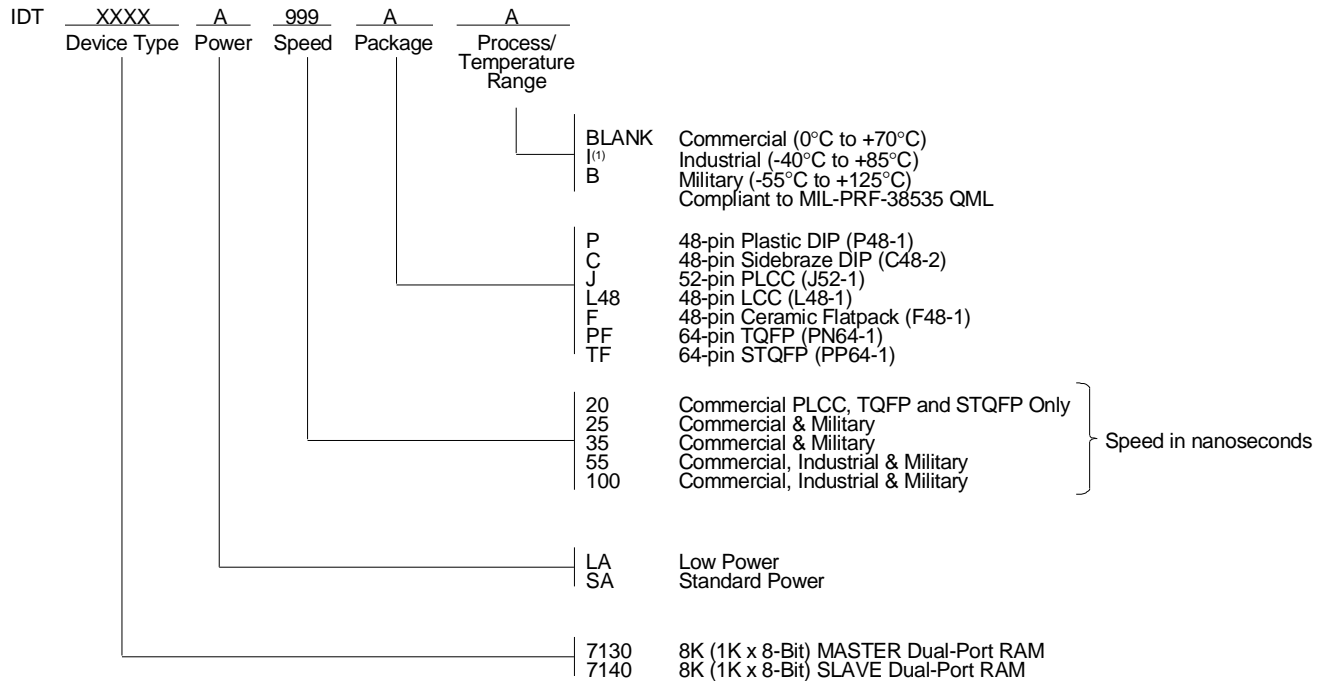

NOTE:

- Industrial temperature range is available on selected PLCC packages in standard temperature.
 For other speeds, packages and powers contact your sales office.

2689 drw 19

Datasheet Document History

- 3/15/99: Initiated datasheet document history
 Converted to new format
 Cosmetic and typographical corrections
 Pages 2 and 3 Added additional notes to pin configurations
- 6/8/99: Changed drawing format
- 8/2/99: Page 2 Corrected package number in note 3
- 9/29/99: Page 2 Fixed pin 1 in DIP pin configuration
- 11/10/99: Replaced IDT logo
- 6/23/00: Page 4 Increased storage temperature parameters
 Clarified TA parameter
 Page 5 DC Electrical parameters—changed wording from "open" to "disabled"
 Changed ±500mV to 0mV in notes



CORPORATE HEADQUARTERS
 2975 Stender Way
 Santa Clara, CA 95054

for SALES:
 800-345-7015 or 408-727-5166
 fax: 408-492-8674
 www.idt.com

for Tech Support:
 831-754-4613
 DualPortHelp@idt.com

The IDT logo is a registered trademark of Integrated Device Technology, Inc.



LittleDiode supplies new, hard to find or obsolete electronic components and semiconductors all over the world.

With over two million different components listed you are sure to find the part you need.

Feel free to visit us today at our online store:

LittleDiode.com

Looking forward to providing you with the best possible service.