



3.3V CMOS Static RAM 1 Meg (128K x 8-Bit) Center Power & Ground Pinout

IDT71V124SA

Features

- ◆ 128K x 8 advanced high-speed CMOS static RAM
- ◆ JEDEC revolutionary pinout (center power/GND) for reduced noise
- ◆ Equal access and cycle times
 - Commercial: 10/12/15/20ns
 - Industrial: 10/12/15/20ns
- ◆ One Chip Select plus one Output Enable pin
- ◆ Inputs and outputs are LVTTTL-compatible
- ◆ Single 3.3V supply
- ◆ Low power consumption via chip deselect
- ◆ Available in a 32-pin 300- and 400-mil Plastic SOJ, and 32-pin Type II TSOP packages.

Description

The IDT71V124 is a 1,048,576-bit high-speed static RAM organized as 128K x 8. It is fabricated using IDT's high-performance, high-reliability CMOS technology. This state-of-the-art technology, combined with innovative circuit design techniques, provides a cost-effective solution for high-speed memory needs. The JEDEC center power/GND pinout reduces noise generation and improves system performance.

The IDT71V124 has an output enable pin which operates as fast as 5ns, with address access times as fast as 9ns available. All bidirectional inputs and outputs of the IDT71V124 are LVTTTL-compatible and operation is from a single 3.3V supply. Fully static asynchronous circuitry is used; no clocks or refreshes are required for operation.

Functional Block Diagram

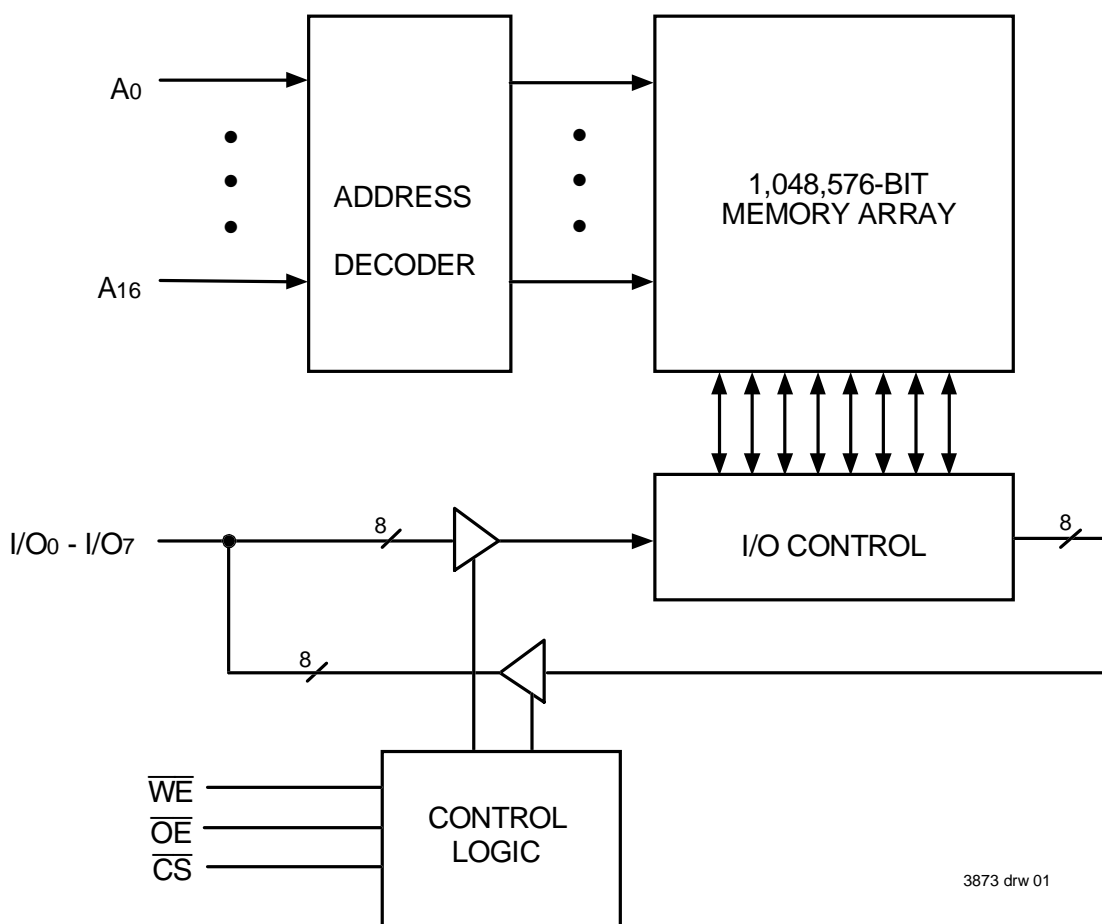

3873 drw 01

NOVEMBER 2003

Pin Configuration

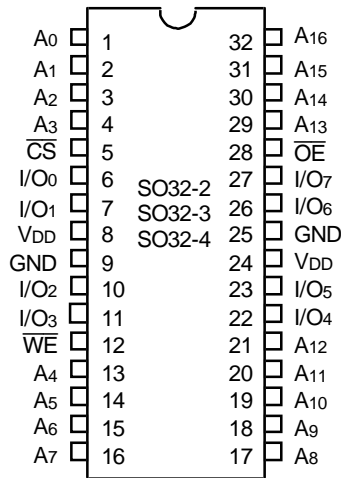

3873 drw 02

SOJ and TSOP Top View

Truth Table⁽¹⁾

\overline{CS}	\overline{OE}	\overline{WE}	I/O	Function
L	L	H	DATAOUT	Read Data
L	X	L	DATAIN	Write Data
L	H	H	High-Z	Output Disabled
H	X	X	High-Z	Deselected – Standby

3873 tbl 01

NOTE:

- H = V_{IH} , L = V_{IL} , X = Don't care.

Capacitance

($T_A = +25^\circ\text{C}$, $f = 1.0\text{MHz}$, SOJ package)

Symbol	Parameter ⁽¹⁾	Conditions	Max.	Unit
C_{IN}	Input Capacitance	$V_{IN} = 3\text{dV}$	6	pF
$C_{I/O}$	I/O Capacitance	$V_{OUT} = 3\text{dV}$	7	pF

3873 tbl 03

NOTE:

- This parameter is guaranteed by device characterization, but is not production tested.

DC Electrical Characteristics

($V_{DD} = \text{Min. to Max.}$, Commercial and Industrial Temperature Ranges)

Symbol	Parameter	Test Conditions	Min.	Max.	Unit
$ I_{L1} $	Input Leakage Current	$V_{DD} = \text{Max.}$, $V_{IN} = \text{GND to } V_{DD}$	—	5	μA
$ I_{LO} $	Output Leakage Current	$V_{DD} = \text{Max.}$, $\overline{CS} = V_{IH}$, $V_{OUT} = \text{GND to } V_{DD}$	—	5	μA
V_{OL}	Output Low Voltage	$I_{OL} = 8\text{mA}$, $V_{DD} = \text{Min.}$	—	0.4	V
V_{OH}	Output High Voltage	$I_{OH} = -4\text{mA}$, $V_{DD} = \text{Min.}$	2.4	—	V

3873 tbl 05

Absolute Maximum Ratings⁽¹⁾

Symbol	Rating	Value	Unit
V_{DD}	Supply Voltage Relative to GND	-0.5 to +4.6	V
V_{IN} , V_{OUT}	Terminal Voltage Relative to GND	-0.5 to $V_{DD}+0.5$	V
T_A	Commercial Operating Temperature	-0 to +70	$^\circ\text{C}$
	Industrial Operating Temperature	-40 to +85	
T_{BIAS}	Temperature Under Bias	-55 to +125	$^\circ\text{C}$
T_{STG}	Storage Temperature	-55 to +125	$^\circ\text{C}$
P_T	Power Dissipation	1.25	W
I_{OUT}	DC Output Current	50	mA

NOTE:

3873 tbl 02

- Stresses greater than those listed under ABSOLUTE MAXIMUM RATINGS may cause permanent damage to the device. This is a stress rating only and functional operation of the device at these or any other conditions above those indicated in the operational sections of this specification is not implied. Exposure to absolute maximum rating conditions for extended periods may affect reliability.

Recommended Operating Temperature and Supply Voltage

Grade	Temperature	GND	V_{DD}
Commercial	$0^\circ\text{C to } +70^\circ\text{C}$	0V	See Below
Industrial	$-40^\circ\text{C to } +85^\circ\text{C}$	0V	See Below

3873 tbl 02a

Recommended DC Operating Conditions

Symbol	Parameter	Min.	Typ.	Max.	Unit
$V_{DD}^{(1)}$	Supply Voltage	3.15	3.3	3.6	V
$V_{DD}^{(2)}$	Supply Voltage	3.0	3.3	3.6	V
V_{SS}	Ground	0	0	0	V
V_{IH}	Input High Voltage	2.0	—	$V_{DD}+0.3^{(3)}$	V
V_{IL}	Input Low Voltage	$-0.5^{(1)}$	—	0.8	V

NOTES:

3873 tbl 04

- For 71V124SA10 only.
- For all speed grades except 71V124SA10.
- $V_{IH}(\text{max.}) = V_{DD}+2\text{V}$ for pulse width less than 5ns, once per cycle.
- $V_{IL}(\text{min.}) = -2\text{V}$ for pulse width less than 5ns, once per cycle.

DC Electrical Characteristics^(1, 2)
(V_{DD} = Min. to Max., V_{LC} = 0.2V, V_{HC} = V_{DD} - 0.2V)

Symbol	Parameter	71V124SA10		71V124SA12		71V124SA15		71V124SA20		Unit
		Com'l	Ind	Com'l	Ind	Com'l	Ind	Com'l	Ind	
I _{CC}	Dynamic Operating Current CS ≤ V _{LC} , Outputs Open, V _{DD} = Max., f = f _{MAX} ⁽³⁾	145	150	130	140	100	120	95	115	mA
I _{SB}	Dynamic Standby Power Supply Current CS ≥ V _{HC} , Outputs Open, V _{DD} = Max., f = f _{MAX} ⁽³⁾	45	50	40	40	35	40	30	35	mA
I _{SB1}	Full Standby Power Supply Current (static) CS ≥ V _{HC} , Outputs Open, V _{DD} = Max., f = 0 ⁽³⁾	10	10	10	10	10	10	10	10	mA

3873 tbl 06

NOTES:

- All values are maximum guaranteed values.
- All inputs switch between 0.2V (Low) and V_{DD}-0.2V (High).
- f_{MAX} = 1/trc (all address inputs are cycling at f_{MAX}); f = 0 means no address input lines are changing.

AC Test Conditions

Input Pulse Levels	GND to 3.0V
Input Rise/Fall Times	3ns
Input Timing Reference Levels	1.5V
Output Reference Levels	1.5V
AC Test Load	See Figure 1 and 2

3873 tbl 07

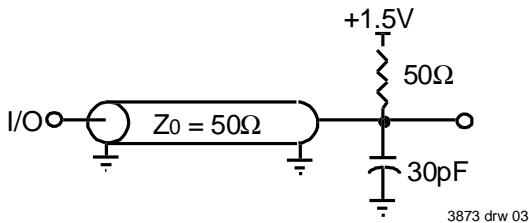

3873 drw 03

Figure 1. AC Test Load

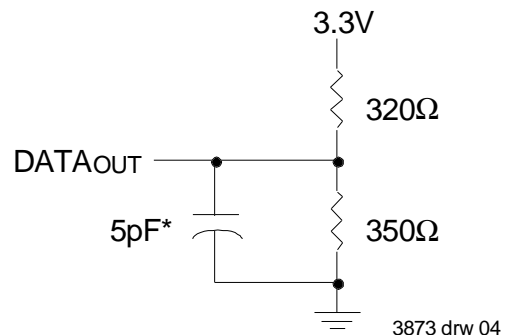

3873 drw 04

*Including jig and scope capacitance.

Figure 2. AC Test Load
 (for t_{CLZ}, t_{OLZ}, t_{CHZ}, t_{OHZ}, t_{OW}, and t_{WHZ})

AC Electrical Characteristics (VDD = Min. to Max., Commercial and Industrial Temperature Ranges)

Symbol	Parameter	71V124SA10		71V124SA12		71V124SA15		71V124SA20		Unit
		Min.	Max.	Min.	Max.	Min.	Max.	Min.	Max.	
READ CYCLE										
t _{RC}	Read Cycle Time	10	—	12	—	15	—	20	—	ns
t _{AA}	Address Access Time	—	10	—	12	—	15	—	20	ns
t _{ACS}	Chip Select Access Time	—	10	—	12	—	15	—	20	ns
t _{CLZ} ⁽¹⁾	Chip Select to Output in Low-Z	4	—	4	—	4	—	4	—	ns
t _{CHZ} ⁽¹⁾	Chip Deselect to Output in High-Z	0	5	0	6	0	7	0	8	ns
t _{OE}	Output Enable to Output Valid	—	5	—	6	—	7	—	8	ns
t _{OLZ} ⁽¹⁾	Output Enable to Output in Low-Z	0	—	0	—	0	—	0	—	ns
t _{OHZ} ⁽¹⁾	Output Disable to Output in High-Z	0	5	0	5	0	5	0	7	ns
t _{OH}	Output Hold from Address Change	4	—	4	—	4	—	4	—	ns
WRITE CYCLE										
t _{WC}	Write Cycle Time	10	—	12	—	15	—	20	—	ns
t _{AW}	Address Valid to End-of-Write	7	—	8	—	10	—	12	—	ns
t _{CW}	Chip Select to End-of-Write	7	—	8	—	10	—	12	—	ns
t _{AS}	Address Set-up Time	0	—	0	—	0	—	0	—	ns
t _{WP}	Write Pulse Width	7	—	8	—	10	—	12	—	ns
t _{WR}	Write Recovery Time	0	—	0	—	0	—	0	—	ns
t _{DW}	Data Valid to End-of-Write	5	—	6	—	7	—	9	—	ns
t _{DH}	Data Hold Time	0	—	0	—	0	—	0	—	ns
t _{OW} ⁽²⁾	Output Active from End-of-Write	3	—	3	—	3	—	4	—	ns
t _{WHZ} ⁽²⁾	Write Enable to Output in High-Z	0	5	0	5	0	5	0	8	ns

3873 tbl 08

NOTES:

1. This parameter guaranteed with the AC load (Figure 2) by device characterization, but is not production tested.

Timing Waveform of Read Cycle No. 1⁽¹⁾

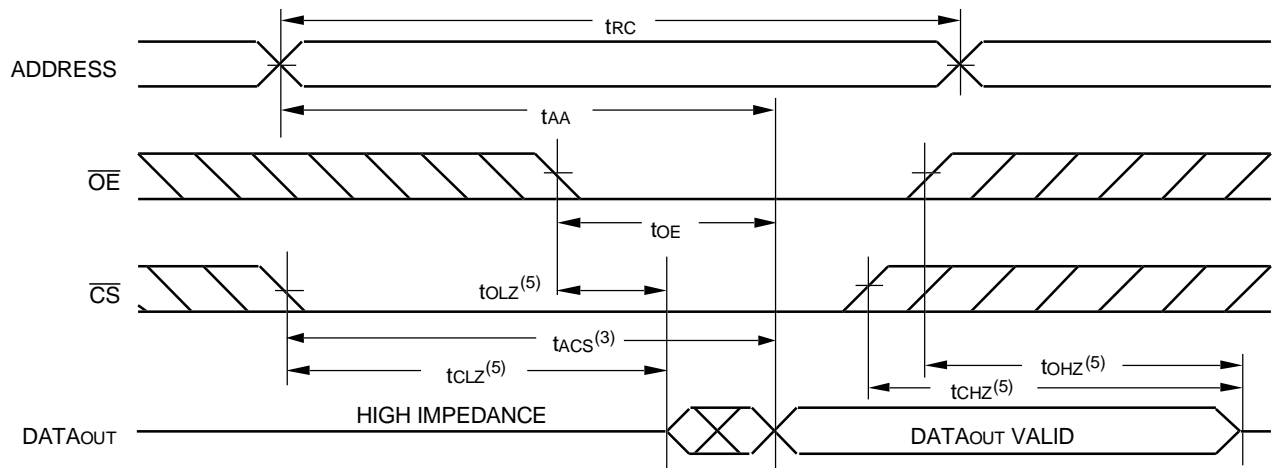

3873 drw 05

Timing Waveform of Read Cycle No. 2^(1, 2, 4)

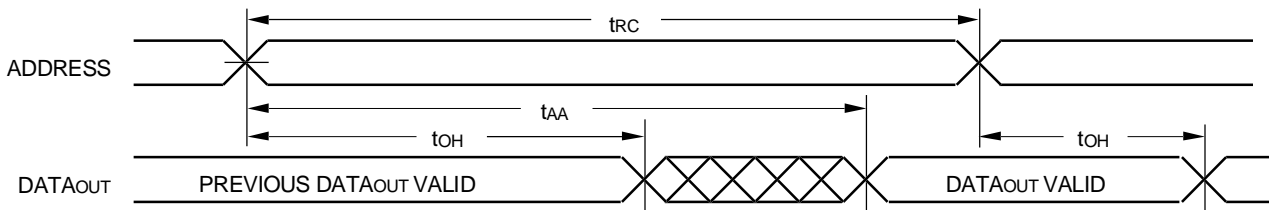

3873 drw 06

NOTES:

1. \overline{WE} is HIGH for Read Cycle.
2. Device is continuously selected, \overline{CS} is LOW.
3. Address must be valid prior to or coincident with the later of \overline{CS} transition LOW; otherwise t_{AA} is the limiting parameter.
4. \overline{OE} is LOW.
5. Transition is measured $\pm 200\text{mV}$ from steady state.

Timing Waveform of Write Cycle No. 1 (\overline{WE} Controlled Timing)^(1,2,4)

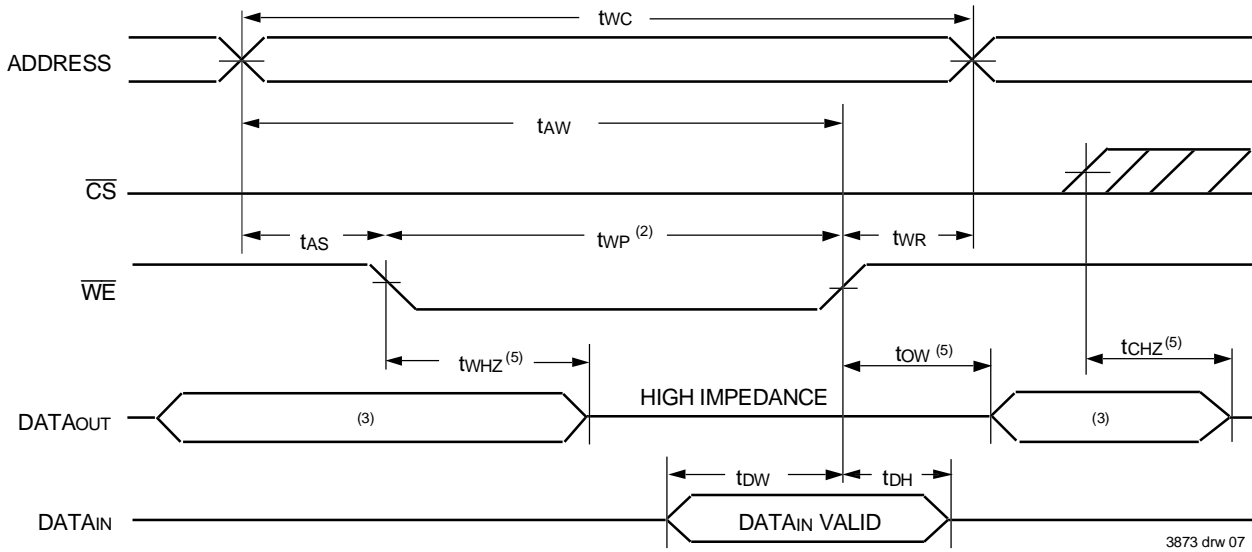

Timing Waveform of Write Cycle No. 2 (\overline{CS} Controlled Timing)^(1, 4)

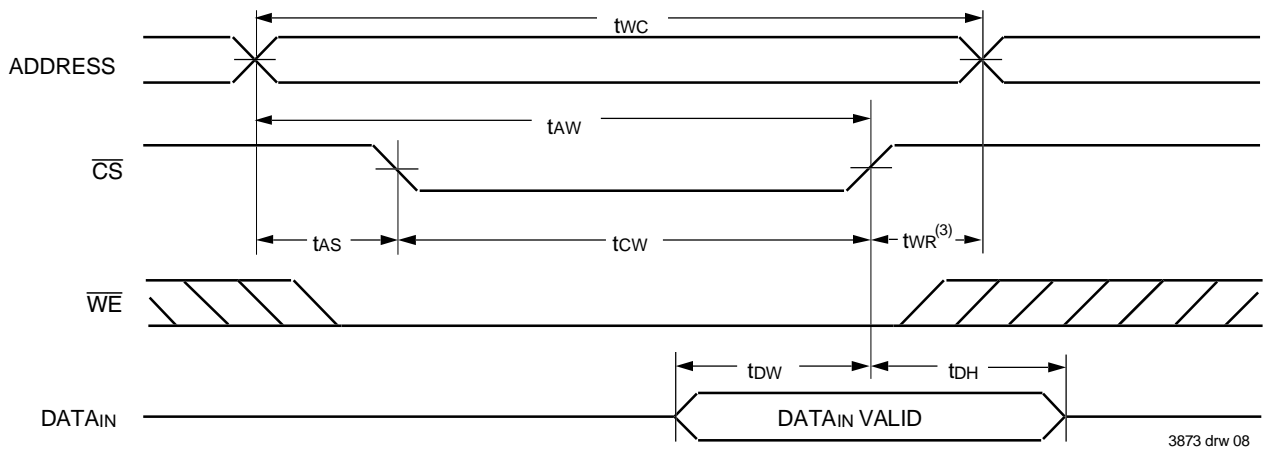

NOTES:

1. A write occurs during the overlap of a LOW \overline{CS} and a LOW \overline{WE} .
2. \overline{OE} is continuously HIGH. During a \overline{WE} controlled write cycle with \overline{OE} LOW, t_{WP} must be greater than or equal to $t_{WHZ} + t_{OW}$ to allow the I/O drivers to turn off and data to be placed on the bus for the required t_{DW} . If \overline{OE} is HIGH during a \overline{WE} controlled write cycle, this requirement does not apply and the minimum write pulse is the specified t_{WP} .
3. During this period, I/O pins are in the output state, and input signals must not be applied.
4. If the \overline{CS} LOW transition occurs simultaneously with or after the \overline{WE} LOW transition, the outputs remain in a high impedance state. \overline{CS} must be active during the t_{CW} write period.
5. Transition is measured $\pm 200mV$ from steady state.

Ordering Information

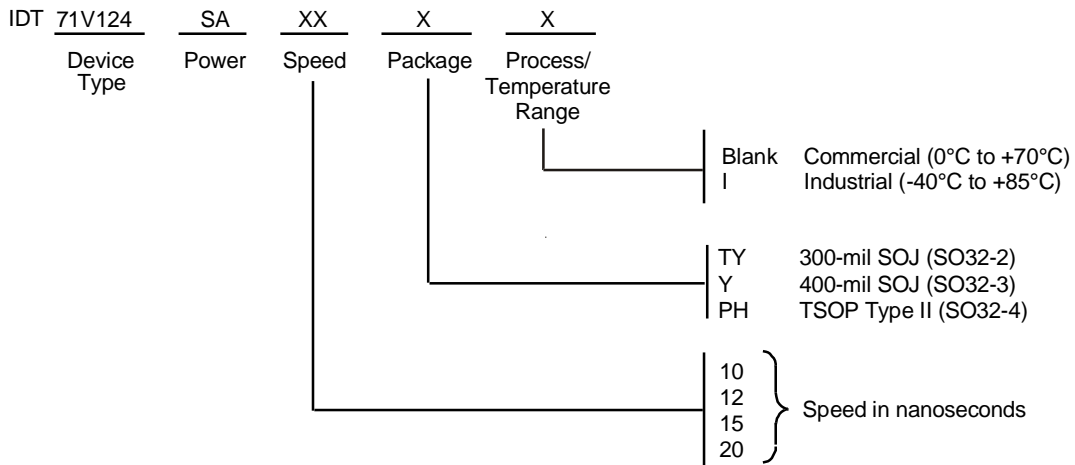

3873 drw 09

Datasheet Document History

11/22/99		Updated to new format
	Pg. 1-4, 7	Added Industrial Temperature range offerings
	Pg. 2	Added Recommended Operating Temperature and Supply Voltage table
	Pg. 6	Revised footnotes on Write Cycle No. 1 diagram
	Pg. 8	Added Datasheet Document History
08/30/00	Pg. 3	Tighten Icc and Isb
	Pg. 4	Tighten AC Characteristics toHz, tow and twhz
08/22/01	Pg. 7	Removed footnote "400-mil SOJ package only offered in 10ns and 12ns speed grade"
11/30/03	Pg. 1,3,7	Added Industrial temperature offering 10ns speed grade



CORPORATE HEADQUARTERS

2975 Stender Way
Santa Clara, CA 95054

for SALES:

800-345-7015 or 408-727-6116
fax: 408-492-8674
www.idt.com

for Tech Support:

sramhelp@idt.com
800-544-7726, x4033

The IDT logo is a registered trademark of Integrated Device Technology, Inc.

This datasheet has been downloaded from:

www.DatasheetCatalog.com

Datasheets for electronic components.



LittleDiode supplies new, hard to find or obsolete electronic components and semiconductors all over the world.

With over two million different components listed you are sure to find the part you need.

Feel free to visit us today at our online store:

LittleDiode.com

Looking forward to providing you with the best possible service.