



Integrated Device Technology, Inc.

LOW POWER 3.3V CMOS FAST SRAM 256K (32K x 8-BIT)

IDT71V256SA

FEATURES

- Ideal for high-performance processor secondary cache
- Commercial (0° to 70°C) and Industrial (-40° to 85°C) temperature options
- Fast access times:
 - Commercial: 10/12/15/20ns
 - Industrial: 15ns
- Low standby current (maximum):
 - 2mA full standby
- Small packages for space-efficient layouts:
 - 28-pin 300 mil SOJ
 - 28-pin 300 mil plastic DIP (Commercial only)
 - 28-pin TSOP Type I
- Produced with advanced high-performance CMOS technology
- Inputs and outputs are LVTTTL-compatible
- Single 3.3V(±0.3V) power supply

DESCRIPTION

The IDT71V256SA is a 262,144-bit high-speed static RAM organized as 32K x 8. It is fabricated using IDT's high-performance, high-reliability CMOS technology.

The IDT71V256SA has outstanding low power characteristics while at the same time maintaining very high performance. Address access times of as fast as 10 ns are ideal for 3.3V secondary cache in 3.3V desktop designs.

When power management logic puts the IDT71V256SA in standby mode, its very low power characteristics contribute to extended battery life. By taking \overline{CS} HIGH, the SRAM will automatically go to a low power standby mode and will remain in standby as long as \overline{CS} remains HIGH. Furthermore, under full standby mode (\overline{CS} at CMOS level, $f=0$), power consumption is guaranteed to always be less than 6.6mW and typically will be much smaller.

The IDT71V256SA is packaged in 28-pin 300 mil SOJ, 28-pin 300 mil plastic DIP, and 28-pin 300 mil TSOP Type I packaging.

FUNCTIONAL BLOCK DIAGRAM

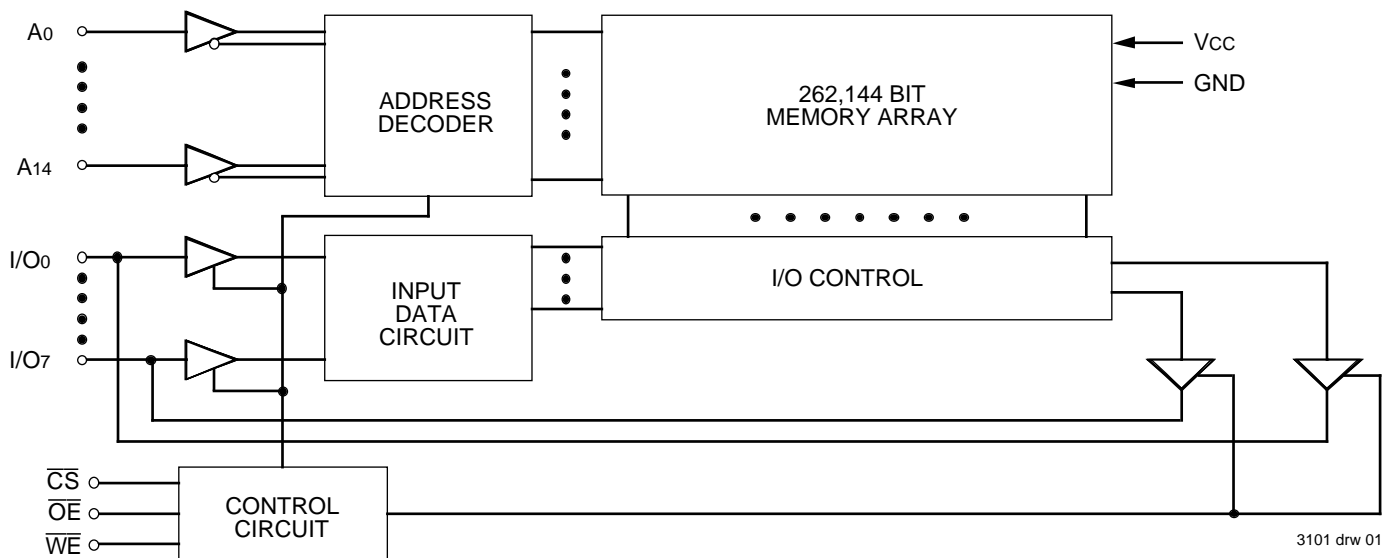

3101 drw 01

The IDT logo is a registered trademark of Integrated Device Technology, Inc.

INDUSTRIAL AND COMMERCIAL TEMPERATURE RANGES

MAY 1997

PIN CONFIGURATIONS

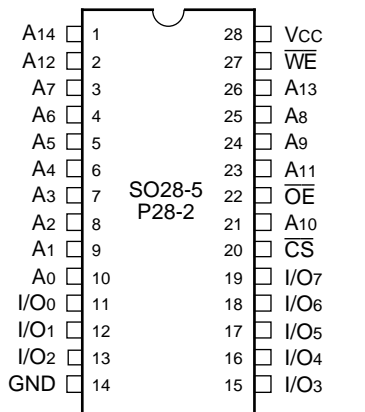

DIP/SOJ
TOP VIEW

3101 drw 02

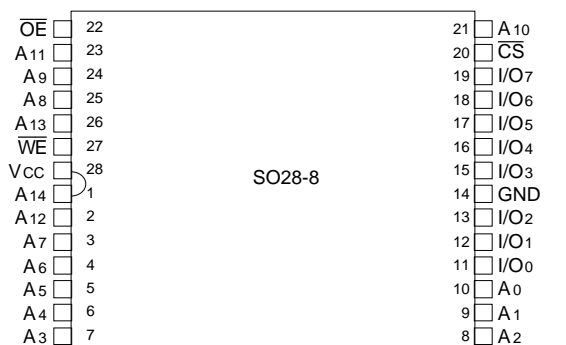

TSOP
TOP VIEW

3101 drw 11

PIN DESCRIPTIONS

Name	Description
A ₀ –A ₁₄	Addresses
I/O ₀ –I/O ₇	Data Input/Output
\overline{CS}	Chip Select
\overline{WE}	Write Enable
\overline{OE}	Output Enable
GND	Ground
V _{CC}	Power

3101 tbl 01

TRUTH TABLE⁽¹⁾

\overline{WE}	\overline{CS}	\overline{OE}	I/O	Function
X	H	X	High-Z	Standby (ISB)
X	V _H C	X	High-Z	Standby (ISB1)
H	L	H	High-Z	Output Disable
H	L	L	DOUT	Read
L	L	X	DIN	Write

NOTE:

1. H = V_{IH}, L = V_{IL}, X = Don't Care

3101 tbl 02

ABSOLUTE MAXIMUM RATINGS⁽¹⁾

Symbol	Rating	Value	Unit
V _{CC}	Supply Voltage Relative to GND	–0.5 to +4.6	V
V _{TERM} ⁽²⁾	Terminal Voltage Relative to GND	–0.5 to V _{CC} +0.5	V
T _{BIAS}	Temperature Under Bias	–55 to +125	°C
T _{STG}	Storage Temperature	–55 to +125	°C
P _T	Power Dissipation	1.0	W
I _{OUT}	DC Output Current	50	mA

NOTES:

3101 tbl 03

- Stresses greater than those listed under ABSOLUTE MAXIMUM RATINGS may cause permanent damage to the device. This is a stress rating only and functional operation of the device at these or any other conditions above those indicated in the operational sections of this specification is not implied. Exposure to absolute maximum rating conditions for extended periods may affect reliability.
- Input, Output, and I/O terminals; 4.6V maximum.

CAPACITANCE

(T_A = +25°C, f = 1.0MHz, SOJ package)

Symbol	Parameter ⁽¹⁾	Conditions	Max.	Unit
C _{IN}	Input Capacitance	V _{IN} = 3dV	6	pF
C _{OUT}	Output Capacitance	V _{OUT} = 3dV	7	pF

NOTE:

3101 tbl 04

- This parameter is determined by device characterization, but is not production tested.

RECOMMENDED OPERATING TEMPERATURE AND SUPPLY VOLTAGE

Grade	Temperature	GND	V _{CC}
Commercial	0°C to +70°C	0V	3.3V ± 0.3V
Industrial	–40°C to +85°C	0V	3.3V ± 0.3V

3101 tbl 05

RECOMMENDED DC OPERATING CONDITIONS

Symbol	Parameter	Min.	Typ.	Max.	Unit
V _{CC}	Supply Voltage	3.0	3.3	3.6	V
GND	Supply Voltage	0	0	0	V
V _{IH}	Input High Voltage - Inputs	2.0	—	5.0	V
V _{IH}	Input High Voltage - I/O	2.0	—	V _{CC} +0.3	V
V _{IL}	Input Low Voltage	–0.3 ⁽¹⁾	—	0.8	V

NOTE:

3101 tbl 06

- V_{IL} (min.) = –2.0V for pulse width less than 5ns, once per cycle.

DC ELECTRICAL CHARACTERISTICS^(1, 2)

($V_{CC} = 3.3V \pm 0.3V$, $V_{LC} = 0.2V$, $V_{HC} = V_{CC} - 0.2V$)

Symbol	Parameter	71V256SA10 ⁽³⁾	71V256SA12 ⁽³⁾	71V256SA15	71V256SA20 ⁽³⁾	Unit
I _{CC}	Dynamic Operating Current $\overline{CS} \leq V_{IL}$, Outputs Open, $V_{CC} = \text{Max.}$, $f = f_{MAX}$ ⁽²⁾	100	90	85	85	mA
I _{SB}	Standby Power Supply Current (TTL Level) $\overline{CS} = V_{IH}$, $V_{CC} = \text{Max.}$, Outputs Open, $f = f_{MAX}$ ⁽²⁾	20	20	20	20	mA
I _{SB1}	Full Standby Power Supply Current (CMOS Level) $\overline{CS} \geq V_{HC}$, $V_{CC} = \text{Max.}$, Outputs Open, $f = 0$ ⁽²⁾ , $V_{IN} \leq V_{LC}$ or $V_{IN} \geq V_{HC}$	2	2	2	2	mA

NOTES:

- All values are maximum guaranteed values.
- $f_{MAX} = 1/t_{RC}$, only address inputs cycling at f_{max} ; $f = 0$ means that no inputs are cycling.
- Commercial temperature range only.

3101 tbl 07

DC ELECTRICAL CHARACTERISTICS

$V_{CC} = 3.3V \pm 0.3V$

Symbol	Parameter	Test Condition	IDT71V256SA			Unit
			Min.	Typ.	Max.	
I _{LI}	Input Leakage Current	$V_{CC} = \text{Max.}$, $V_{IN} = \text{GND to } V_{CC}$	—	—	2	μA
I _{LO}	Output Leakage Current	$V_{CC} = \text{Max.}$, $\overline{CS} = V_{IH}$, $V_{OUT} = \text{GND to } V_{CC}$	—	—	2	μA
V _{OL}	Output Low Voltage	$I_{OL} = 8\text{mA}$, $V_{CC} = \text{Min.}$	—	—	0.4	V
V _{OH}	Output High Voltage	$I_{OH} = -4\text{mA}$, $V_{CC} = \text{Min.}$	2.4	—	—	V

3101 tbl 08

AC TEST CONDITIONS

Input Pulse Levels	GND to 3.0V
Input Rise/Fall Times	3ns
Input Timing Reference Levels	1.5V
Output Reference Levels	1.5V
AC Test Load	See Figures 1 and 2

3101 tbl 09

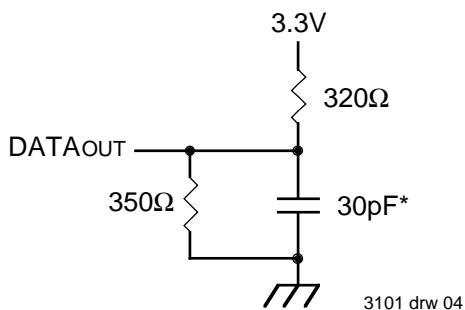

Figure 1. AC Test Load

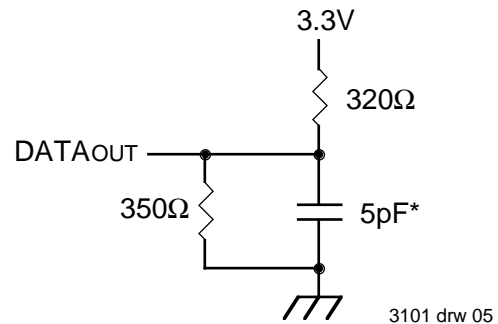

Figure 2. AC Test Load
(for t_{CLZ}, t_{OLZ}, t_{CHZ}, t_{OHZ}, t_{OW}, t_{WHZ})

*Includes scope and jig capacitances

AC ELECTRICAL CHARACTERISTICS ($V_{CC} = 3.3V \pm 0.3V$)

Symbol	Parameter	71V256SA10 ⁽²⁾		71V256SA12 ⁽²⁾		71V256SA15		71V256SA20 ⁽²⁾		Unit
		Max.	Min.	Min.	Max.	Min.	Max.	Min.	Max.	
Read Cycle										
t _{RC}	Read Cycle Time	10	—	12	—	15	—	20	—	ns
t _{AA}	Address Access Time	—	10	—	12	—	15	—	20	ns
t _{ACS}	Chip Select Access Time	—	10	—	12	—	15	—	20	ns
t _{CLZ} ⁽¹⁾	Chip Select to Output in Low-Z	5	—	5	—	5	—	5	—	ns
t _{CHZ} ⁽¹⁾	Chip Select to Output in High-Z	0	8	0	8	0	9	0	10	ns
t _{OE}	Output Enable to Output Valid	—	6	—	6	—	7	—	8	ns
t _{OLZ} ⁽¹⁾	Output Enable to Output in Low-Z	3	—	3	—	0	—	0	—	ns
t _{OHZ} ⁽¹⁾	Output Disable to Output in High-Z	2	6	2	6	0	7	0	8	ns
t _{OH}	Output Hold from Address Change	3	—	3	—	3	—	3	—	ns
Write Cycle										
t _{WC}	Write Cycle Time	10	—	12	—	15	—	20	—	ns
t _{AW}	Address Valid to End-of-Write	9	—	9	—	10	—	15	—	ns
t _{CW}	Chip Select to End-of-Write	9	—	9	—	10	—	15	—	ns
t _{AS}	Address Set-up Time	0	—	0	—	0	—	0	—	ns
t _{WP}	Write Pulse Width	9	—	9	—	10	—	15	—	ns
t _{WR}	Write Recovery Time	0	—	0	—	0	—	0	—	ns
t _{DW}	Data to Write Time Overlap	6	—	6	—	7	—	8	—	ns
t _{DH}	Data Hold from Write Time	0	—	0	—	0	—	0	—	ns
t _{OW} ⁽¹⁾	Output Active from End-of-Write	4	—	4	—	4	—	4	—	ns
t _{WHZ} ⁽¹⁾	Write Enable to Output in High-Z	1	8	1	8	1	9	1	10	ns

NOTE:

1. This parameter guaranteed with the AC test load (Figure 2) by device characterization, but is not production tested.
2. Commercial temperature range only.

3101 tbl 10

TIMING WAVEFORM OF READ CYCLE NO. 1⁽¹⁾

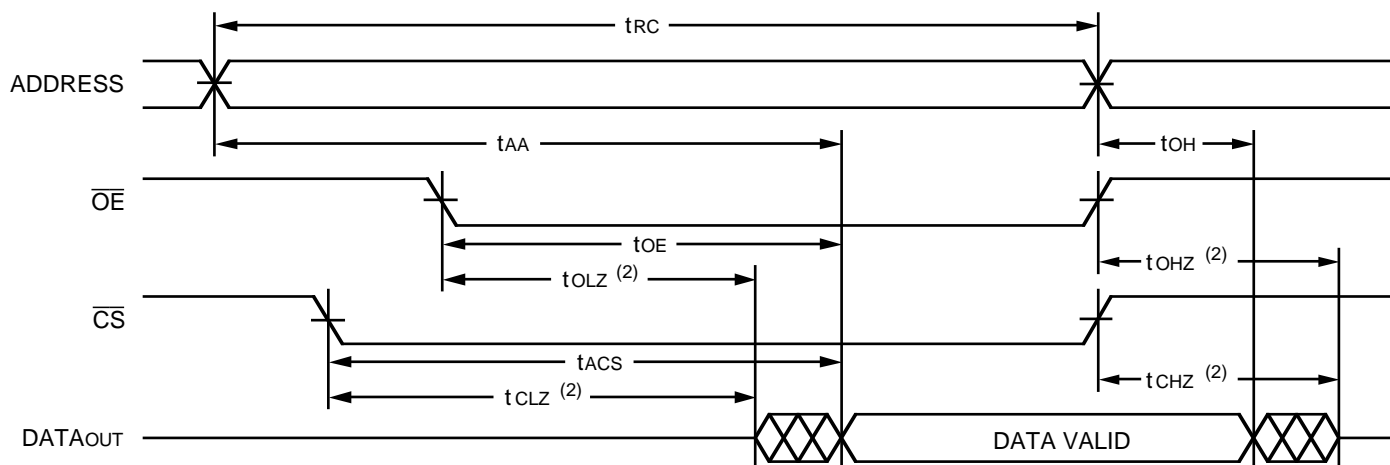

3101 drw 06

NOTES:

1. WE is HIGH for Read cycle.
2. Transition is measured $\pm 200mV$ from steady state.

TIMING WAVEFORM OF READ CYCLE NO. 2^(1, 2, 4)

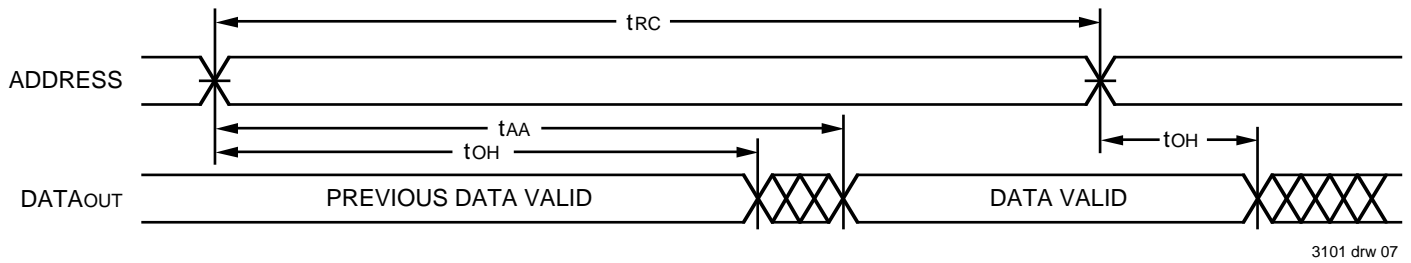

TIMING WAVEFORM OF READ CYCLE NO. 3^(1, 3, 4)

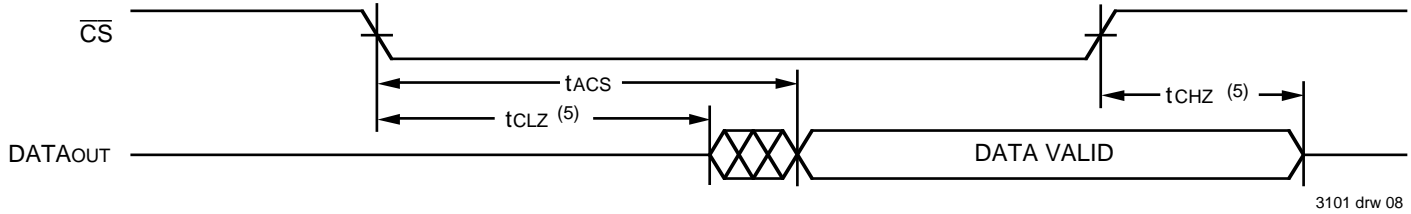

NOTES:

1. \overline{WE} is HIGH for Read cycle.
2. Device is continuously selected, \overline{CS} is LOW.
3. Address valid prior to or coincident with \overline{CS} transition LOW.
4. \overline{OE} is LOW.
5. Transition is measured $\pm 200\text{mV}$ from steady state.

TIMING WAVEFORM OF WRITE CYCLE NO. 1 (\overline{WE} CONTROLLED TIMING)^(1, 2, 3, 5, 7)

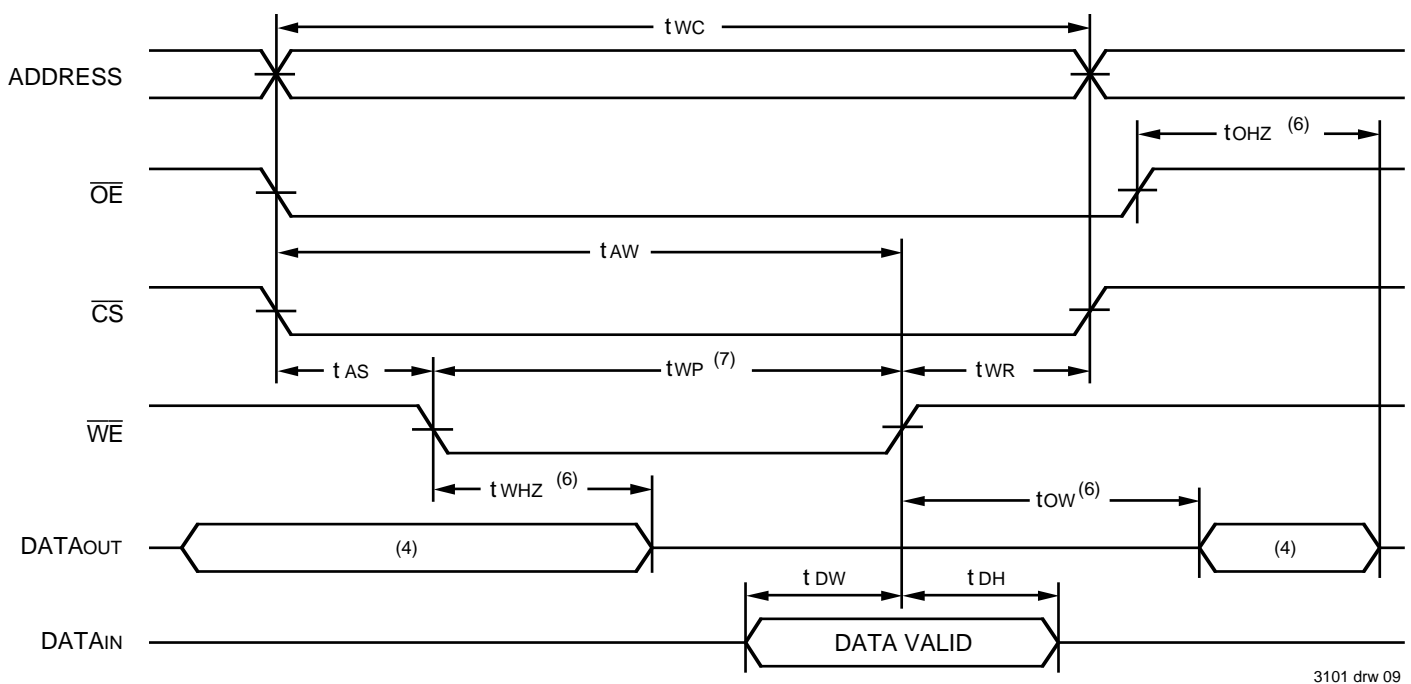

NOTES:

1. \overline{WE} or \overline{CS} must be HIGH during all address transitions.
2. A write occurs during the overlap of a LOW \overline{CS} and a LOW \overline{WE} .
3. t_{WR} is measured from the earlier of \overline{CS} or \overline{WE} going HIGH to the end of the write cycle.
4. During this period, I/O pins are in the output state so that the input signals must not be applied.
5. If the \overline{CS} LOW transition occurs simultaneously with or after the \overline{WE} LOW transition, the outputs remain in a high-impedance state.
6. Transition is measured $\pm 200\text{mV}$ from steady state.
7. If \overline{OE} is LOW during a \overline{WE} controlled write cycle, the write pulse width must be the larger of t_{WP} or $(t_{WHZ} + t_{DW})$ to allow the I/O drivers to turn off and data to be placed on the bus for the required t_{DW} . If \overline{OE} is HIGH during a \overline{WE} controlled write cycle, this requirement does not apply and the write pulse can be as short as the specified t_{WP} .

TIMING WAVEFORM OF WRITE CYCLE NO. 2 (\overline{CS} CONTROLLED TIMING)^(1, 2, 3, 4)

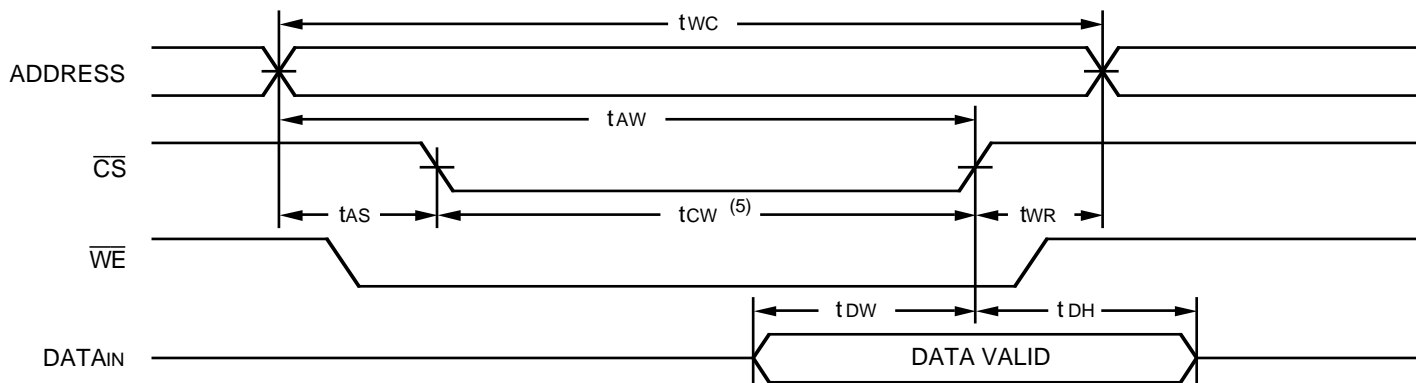

3101 drw 10

NOTES:

1. \overline{WE} or \overline{CS} must be HIGH during all address transitions.
2. A write occurs during the overlap of a LOW \overline{CS} and a LOW \overline{WE} .
3. t_{WR} is measured from the earlier of \overline{CS} or \overline{WE} going HIGH to the end of the write cycle.
4. If the \overline{CS} LOW transition occurs simultaneously with or after the \overline{WE} LOW transition, the outputs remain in a high-impedance state.
5. If \overline{OE} is LOW during a \overline{WE} controlled write cycle, the write pulse width must be the larger of t_{WP} or $(t_{WHZ} + t_{DW})$ to allow the I/O drivers to turn off and data to be placed on the bus for the required t_{DW} . If \overline{OE} is HIGH during a \overline{WE} controlled write cycle, this requirement does not apply and the write pulse can be as short as the specified t_{WP} .

ORDERING INFORMATION - COMMERCIAL

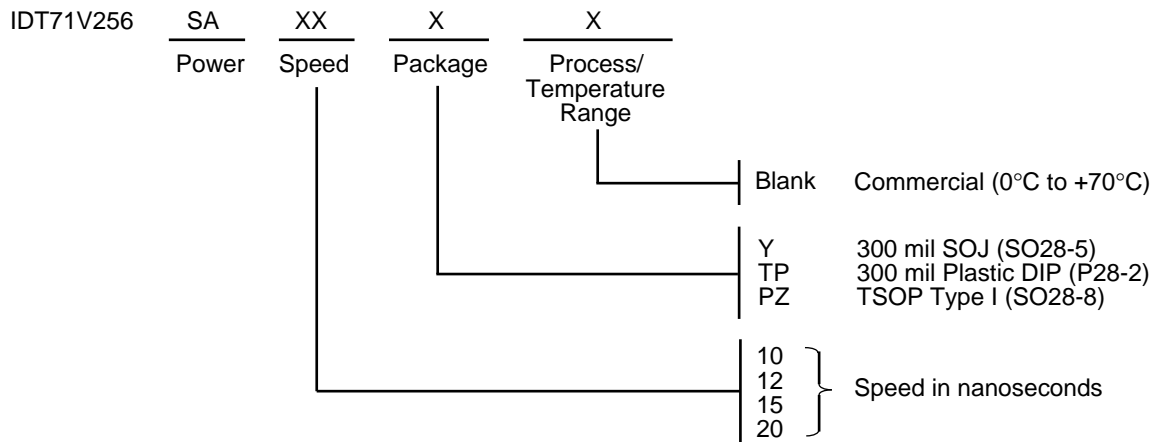

3101 drw 11

ORDERING INFORMATION - INDUSTRIAL

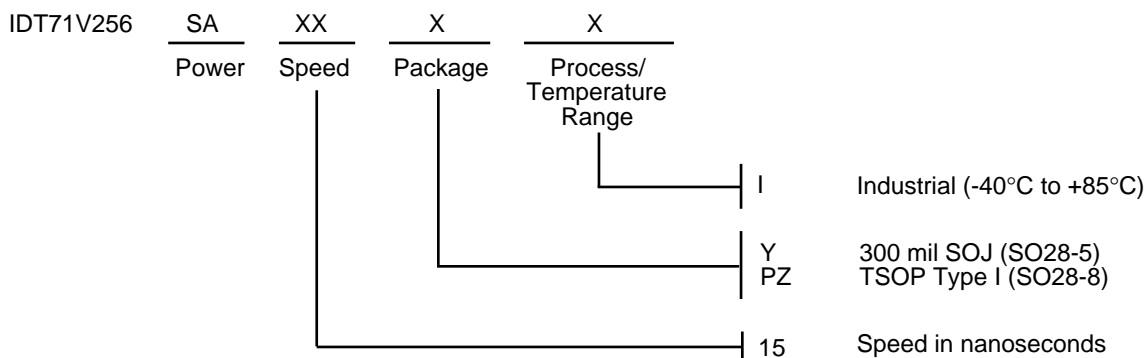

3101 drw 12

This datasheet has been downloaded from:

www.DatasheetCatalog.com

Datasheets for electronic components.



LittleDiode supplies new, hard to find or obsolete electronic components and semiconductors all over the world.

With over two million different components listed you are sure to find the part you need.

Feel free to visit us today at our online store:

LittleDiode.com

Looking forward to providing you with the best possible service.