



**64K x 32
3.3V Synchronous SRAM
Flow-Through Outputs
Burst Counter, Single Cycle Deselect**

IDT71V633

Features

- ◆ 64K x 32 memory configuration
- ◆ Supports high performance system speed
 - Commercial:*
 - 11 11ns Clock-to-Data Access (50 MHz)
 - Commercial and Industrial:*
 - 12 12ns Clock-to-Data Access (50 MHz)
- ◆ Single-cycle deselect functionality (Compatible with Micron Part # MT58LC64K32B2LG-XX)
- ◆ $\overline{\text{LBO}}$ input selects interleaved or linear burst mode
- ◆ Self-timed write cycle with global write control ($\overline{\text{GW}}$), byte write enable ($\overline{\text{BWE}}$), and byte writes ($\overline{\text{BW}}_x$)
- ◆ Power down controlled by ZZ input
- ◆ Single 3.3V power supply (+10/-5%)
- ◆ Packaged in a JEDEC Standard 100-pin rectangular plastic thin quad flatpack (TQFP).

Description

The IDT71V633 is a 3.3V high-speed 2,097,152-bit (2-Mbit) SRAM organized as 64K x 32 with full support of various processor interfaces including the Pentium™ and PowerPC™. The flow-through burst archi-

ture provides cost-effective 2-1-1-1 performance for processors up to 50 MHz.

The IDT71V633 SRAM contains write, data-input, address and control registers. There are no registers in the data output path (flow-through architecture). Internal logic allows the SRAM to generate a self-timed write based upon a decision which can be left until the extreme end of the write cycle.

The burst mode feature offers the highest level of performance to the system designer, as the IDT71V633 can provide four cycles of data for a single address presented to the SRAM. An internal burst address counter accepts the first cycle address from the processor, initiating the access sequence. The first cycle of output data will flow-through from the array after a clock-to-data access time delay from the rising clock edge of the same cycle. If burst mode operation is selected ($\overline{\text{ADV}}=\text{LOW}$), the subsequent three cycles of output data will be available to the user on the next three rising clock edges. The order of these three addresses will be defined by the internal burst counter and the $\overline{\text{LBO}}$ input pin.

The IDT71V633 SRAM utilizes IDT's high-performance 3.3V CMOS process, and is packaged in a JEDEC Standard 14mm x 20mm 100-pin thin plastic quad flatpack (TQFP).

Pin Description

A ₀ -A ₁₅	Address Inputs	Input	Synchronous
$\overline{\text{CE}}$	Chip Enable	Input	Synchronous
CS ₀ , $\overline{\text{CS}}_1$	Chips Selects	Input	Synchronous
$\overline{\text{OE}}$	Output Enable	Input	Asynchronous
$\overline{\text{GW}}$	Global Write Enable	Input	Synchronous
$\overline{\text{BWE}}$	Byte Write Enable	Input	Synchronous
$\overline{\text{BW}}_1\text{-}\overline{\text{BW}}_4$	Individual Byte Write Selects	Input	Synchronous
CLK	Clock Input	Input	N/A
$\overline{\text{ADV}}$	Burst Address Advance	Input	Synchronous
$\overline{\text{ADSC}}$	Address Status (Cache Controller)	Input	Synchronous
$\overline{\text{ADSP}}$	Address Status (Processor)	Input	Synchronous
$\overline{\text{LBO}}$	Linear / Interleaved Burst Order	Input	DC
ZZ	Sleep Mode	Input	Asynchronous
I/O ₀ -I/O ₃₁	Data Input/Output	I/O	Synchronous
V _{DD} , V _{DDQ}	Core and I/O Power Supply (3.3V)	Power	N/A
V _{SS} , V _{SSQ}	Array Ground, I/O Ground	Power	N/A

Pentium is a trademark of Intel Corp.
PowerPC is a trademark of International Business Machines, Inc.

3780 ibl 01

AUGUST 2001

Pin Definitions⁽¹⁾

Symbol	Pin Function	I/O	Active	Description
A0–A15	Address Inputs	I	N/A	Synchronous Address inputs. The address register is triggered by a combination of the rising edge of CLK and \overline{ADSC} Low or \overline{ADSP} Low and \overline{CE} Low.
\overline{ADSC}	Address Status (Cache Controller)	I	LOW	Synchronous Address Status from Cache Controller. \overline{ADSC} is an active LOW input that is used to load the address registers with new addresses. \overline{ADSC} is NOT gated by \overline{CE} .
\overline{ADSP}	Address Status (Processor)	I	LOW	Synchronous Address Status from Processor. \overline{ADSP} is an active LOW input that is used to load the address registers with new addresses. \overline{ADSP} is gated by \overline{CE} .
\overline{ADV}	Burst Address Advance	I	LOW	Synchronous Address Advance. \overline{ADV} is an active LOW input that is used to advance the internal burst counter, controlling burst access after the initial address is loaded. When this input is HIGH the burst counter is not incremented; that is, there is no address advance.
\overline{BWE}	Byte Write Enable	I	LOW	Synchronous byte write enable gates the byte write inputs $\overline{BW1}$ – $\overline{BW4}$. If \overline{BWE} is LOW at the rising edge of CLK then \overline{BWx} inputs are passed to the next stage in the circuit. A byte write can still be blocked if \overline{ADSP} is LOW at the rising edge of CLK. If \overline{ADSP} is HIGH and \overline{BWx} is LOW at the rising edge of CLK then data will be written to the SRAM. If \overline{BWE} is HIGH then the byte write inputs are blocked and only \overline{GW} can initiate a write cycle.
$\overline{BW1}$ – $\overline{BW4}$	Individual Byte Write Enables	I	LOW	Synchronous byte write enables. $\overline{BW1}$ controls I/O(7:0), $\overline{BW2}$ controls I/O(15:8), etc. Any active byte write causes all outputs to be disabled. \overline{ADSP} LOW disables all byte writes. $\overline{BW1}$ – $\overline{BW4}$ must meet specified setup and hold times with respect to CLK.
\overline{CE}	Chip Enable	I	LOW	Synchronous chip enable. \overline{CE} is used with CS_0 and \overline{CS}_1 to enable the IDT71V633. \overline{CE} also gates \overline{ADSP} .
CLK	Clock	I	N/A	This is the clock input. All timing references for the device are made with respect to this input.
CS_0	Chip Select 0	I	HIGH	Synchronous active HIGH chip select. CS_0 is used with \overline{CE} and \overline{CS}_1 to enable the chip.
\overline{CS}_1	Chip Select 1	I	LOW	Synchronous active LOW chip select. \overline{CS}_1 is used with \overline{CE} and CS_0 to enable the chip.
\overline{GW}	Global Write Enable	I	LOW	Synchronous global write enable. This input will write all four 8-bit data bytes when LOW on the rising edge of CLK. \overline{GW} supercedes individual byte write enables.
I/O0–I/O31	Data Input/Output	I/O	N/A	Synchronous data input/output (I/O) pins. Only the data input path is registered and triggered by the rising edge of CLK. Outputs are Flow-Through.
\overline{LBO}	Linear Burst	I	LOW	When \overline{LBO} is HIGH the Interleaved Order (Intel) burst sequence is selected. When \overline{LBO} is LOW the Linear (PowerPC) burst sequence is selected. \overline{LBO} has an internal pull-up resistor.
\overline{OE}	Output Enable	I	LOW	Asynchronous output enable. When \overline{OE} is HIGH the I/O pins are in a high-impedance state. When \overline{OE} is LOW the data output drivers are enabled if the chip is also selected.
VDD	Power Supply	N/A	N/A	3.3V core power supply inputs.
VDDQ	Power Supply	N/A	N/A	3.3V I/O power supply inputs.
VSS	Ground	N/A	N/A	Core ground pins.
VSSQ	Ground	N/A	N/A	I/O ground pins.
NC	No Connect	N/A	N/A	NC pins are not electrically connected to the chip.
ZZ	Sleep Mode	I	HIGH	Asynchronous sleep mode input. ZZ HIGH will gate the CLK internally and power down the IDT71V633 to its lowest power consumption level. Data retention is guaranteed in Sleep Mode. ZZ has an internal pull-down resistor.

3780 tbl 02

NOTE:

1. All synchronous inputs must meet specified setup and hold times with respect to CLK.

Functional Block Diagram

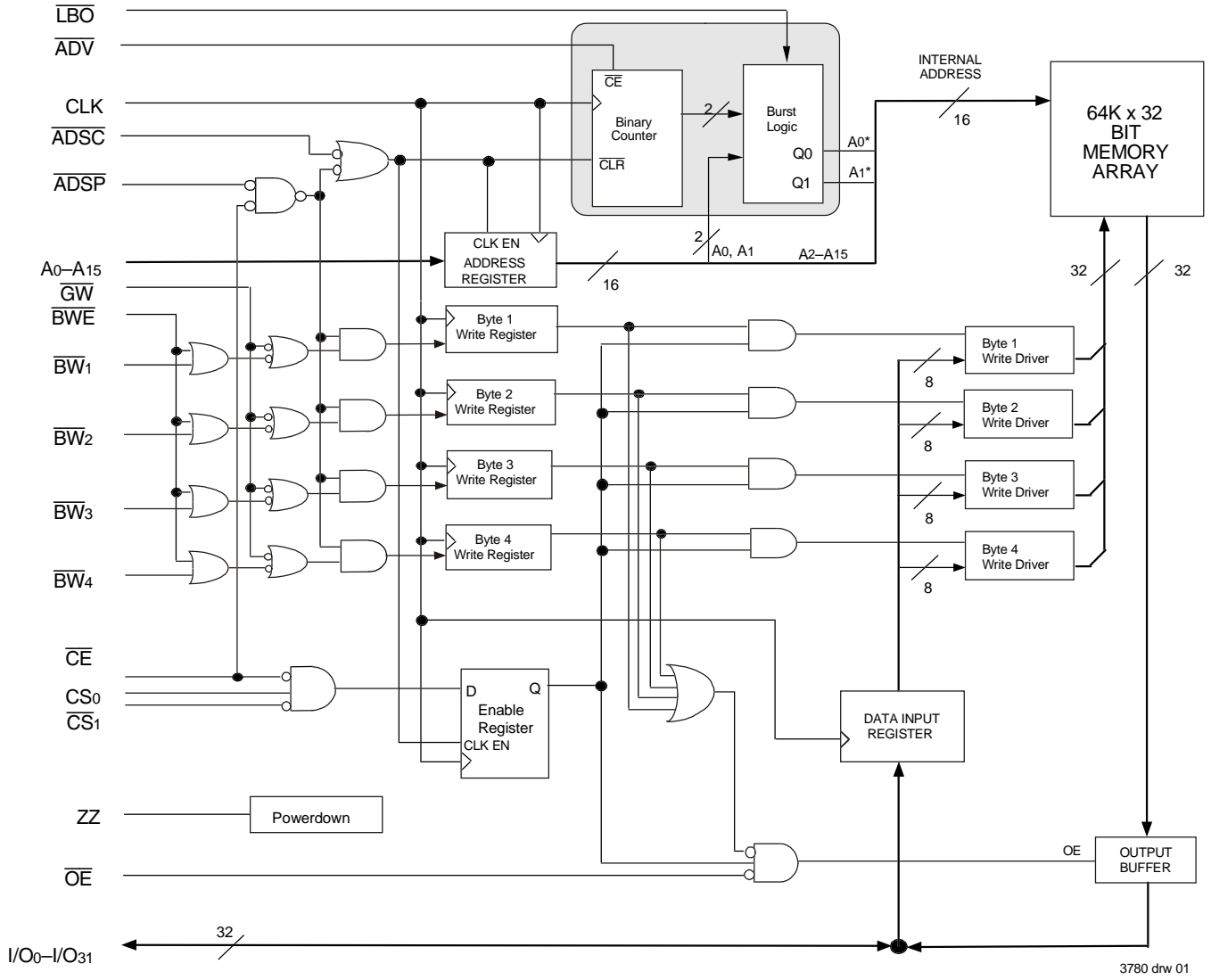

3780 drw 01

Absolute Maximum DC Ratings⁽¹⁾

Symbol	Rating	Value	Unit
V _{TERM} ⁽²⁾	Terminal Voltage with Respect to GND	-0.5 to +4.6	V
V _{TERM} ⁽³⁾	Terminal Voltage with Respect to GND	-0.5 to V _{DD} +0.5	V
T _A	Operating Temperature	0 to +70	°C
T _{BIAS}	Temperature Under Bias	-55 to +125	°C
T _{STG}	Storage Temperature	-55 to +125	°C
P _T	Power Dissipation	1.2	W
I _{OUT}	DC Output Current	50	mA

3780 tbl 05

NOTES:

- Stresses greater than those listed under ABSOLUTE MAXIMUM RATINGS may cause permanent damage to the device. This is a stress rating only and functional operation of the device at these or any other conditions above those indicated in the operational sections of this specification is not implied. Exposure to absolute maximum rating conditions for extended periods may affect reliability.
- V_{DD}, V_{DDQ} and input terminals only.
- I/O terminals.

Capacitance (T_A = +25°C, f = 1.0MHz, TQFP package)

Symbol	Parameter ⁽¹⁾	Conditions	Max.	Unit
C _{IN}	Input Capacitance	V _{IN} = 3dV	4	pF
C _{I/O}	I/O Capacitance	V _{OUT} = 3dV	8	pF

3780 tbl 06

NOTE:

- This parameter is guaranteed by device characterization, but not production tested.

Recommended Operating Temperature and Supply Voltage

Grade	Temperature	V _{SS}	V _{DD}	V _{DDQ}
Commercial	0°C to +70°C	0V	3.3V+10/-5%	3.3V+10/-5%
Industrial	-40°C to +85°C	0V	3.3V+10/-5%	3.3V+10/-5%

3780 tbl 03

Recommended DC Operating Conditions

Symbol	Parameter	Min.	Typ.	Max.	Unit
V _{DD}	Core Supply Voltage	3.135	3.3	3.63	V
V _{DDQ}	I/O Supply Voltage	3.135	3.3	3.63	V
V _{SS} , V _{SSQ}	Ground	0	0	0	V
V _{IH}	Input High Voltage	2.0 ⁽¹⁾	—	V _{DDQ} +0.3 ⁽²⁾	V
V _{IL}	Input Low Voltage	-0.5 ⁽³⁾	—	0.8	V

3780 tbl 04

NOTES:

- V_{IH} and V_{IL} as indicated is for both input and I/O pins.
- V_{IH} (max) = 6.0V for pulse width less than tcyc/2, once per cycle.
- V_{IL} (min) = -1.0V for pulse width less than tcyc/2, once per cycle.

Pin Configuration

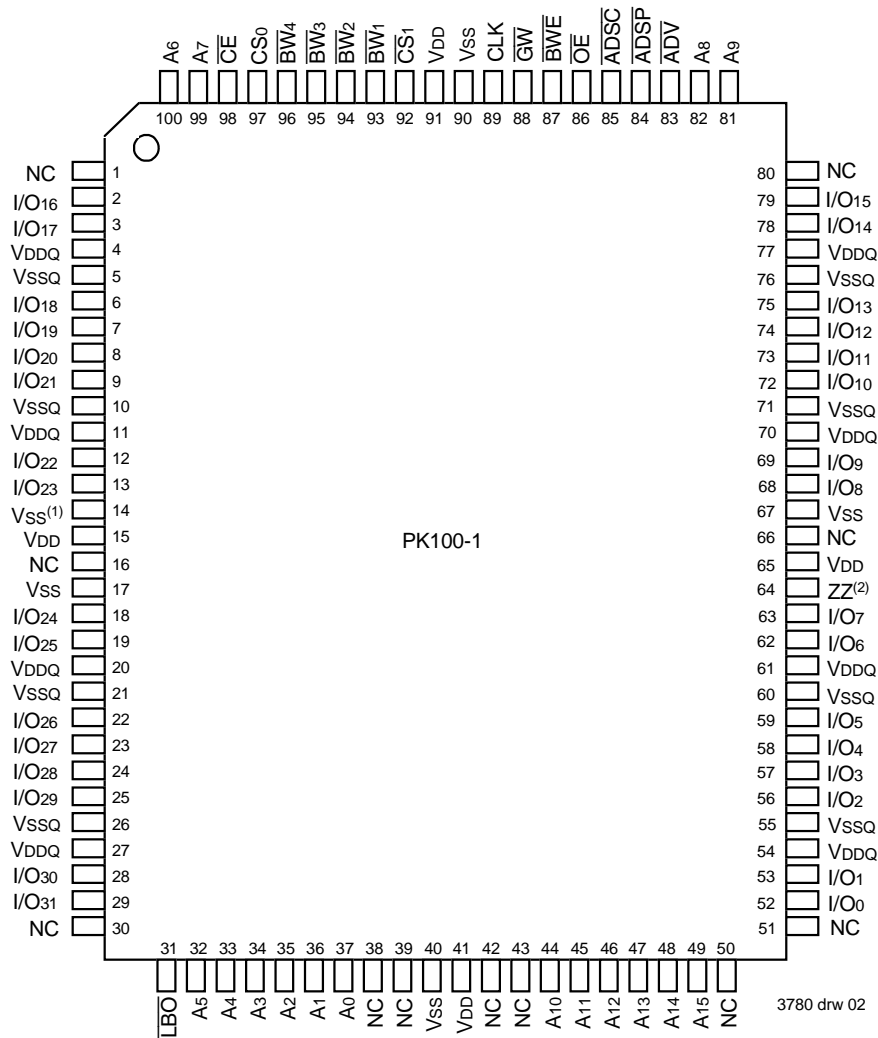

Top View TQFP

NOTES

1. Pin 14 does not have to be directly connected to Vss as long as the input voltage is $\leq V_{IL}$.
2. Pin 64 can be left unconnected and the device will always remain in active mode.

Synchronous Truth Table(1,2)

Operation	Address Used	\overline{CE}	CS_0	\overline{CS}_1	\overline{ADSP}	\overline{ADSC}	\overline{ADV}	\overline{GW}	\overline{BWE}	\overline{BW}_x	$\overline{OE}^{(3)}$	CLK	I/O
Deselected Cycle, Power Down	None	H	X	X	X	L	X	X	X	X	X	↑	Hi-Z
Deselected Cycle, Power Down	None	L	X	H	L	X	X	X	X	X	X	↑	Hi-Z
Deselected Cycle, Power Down	None	L	L	X	L	X	X	X	X	X	X	↑	Hi-Z
Deselected Cycle, Power Down	None	L	X	H	X	L	X	X	X	X	X	↑	Hi-Z
Deselected Cycle, Power Down	None	L	L	X	X	L	X	X	X	X	X	↑	Hi-Z
Read Cycle, Begin Burst	External	L	H	L	L	X	X	X	X	X	L	↑	DOUT
Read Cycle, Begin Burst	External	L	H	L	L	X	X	X	X	X	H	↑	Hi-Z
Read Cycle, Begin Burst	External	L	H	L	H	L	X	H	H	X	L	↑	DOUT
Read Cycle, Begin Burst	External	L	H	L	H	L	X	H	L	H	L	↑	DOUT
Read Cycle, Begin Burst	External	L	H	L	H	L	X	H	L	H	H	↑	Hi-Z
Write Cycle, Begin Burst	External	L	H	L	H	L	X	H	L	L	X	↑	DIN
Write Cycle, Begin Burst	External	L	H	L	H	L	X	L	X	X	X	↑	DIN
Read Cycle, Continue Burst	Next	X	X	X	H	H	L	H	H	X	L	↑	DOUT
Read Cycle, Continue Burst	Next	X	X	X	H	H	L	H	H	X	H	↑	Hi-Z
Read Cycle, Continue Burst	Next	X	X	X	H	H	L	H	X	H	L	↑	DOUT
Read Cycle, Continue Burst	Next	X	X	X	H	H	L	H	X	H	H	↑	Hi-Z
Read Cycle, Continue Burst	Next	H	X	X	X	H	L	H	H	X	L	↑	DOUT
Read Cycle, Continue Burst	Next	H	X	X	X	H	L	H	H	X	H	↑	Hi-Z
Read Cycle, Continue Burst	Next	H	X	X	X	H	L	H	X	H	L	↑	DOUT
Read Cycle, Continue Burst	Next	H	X	X	X	H	L	H	X	H	H	↑	Hi-Z
Write Cycle, Continue Burst	Next	X	X	X	H	H	L	H	L	L	X	↑	DIN
Write Cycle, Continue Burst	Next	X	X	X	H	H	L	L	X	X	X	↑	DIN
Write Cycle, Continue Burst	Next	H	X	X	X	H	L	H	L	L	X	↑	DIN
Write Cycle, Continue Burst	Next	H	X	X	X	H	L	L	X	X	X	↑	DIN
Read Cycle, Suspend Burst	Current	X	X	X	H	H	H	H	H	X	L	↑	DOUT
Read Cycle, Suspend Burst	Current	X	X	X	H	H	H	H	H	X	H	↑	Hi-Z
Read Cycle, Suspend Burst	Current	X	X	X	H	H	H	H	X	H	L	↑	DOUT
Read Cycle, Suspend Burst	Current	X	X	X	H	H	H	H	X	H	H	↑	Hi-Z
Read Cycle, Suspend Burst	Current	H	X	X	X	H	H	H	H	X	L	↑	DOUT
Read Cycle, Suspend Burst	Current	H	X	X	X	H	H	H	H	X	H	↑	Hi-Z
Read Cycle, Suspend Burst	Current	H	X	X	X	H	H	H	X	H	L	↑	DOUT
Read Cycle, Suspend Burst	Current	H	X	X	X	H	H	H	X	H	H	↑	Hi-Z
Write Cycle, Suspend Burst	Current	X	X	X	H	H	H	H	L	L	X	↑	DIN
Write Cycle, Suspend Burst	Current	X	X	X	H	H	H	L	X	X	X	↑	DIN
Write Cycle, Suspend Burst	Current	H	X	X	X	H	H	H	L	L	X	↑	DIN
Write Cycle, Suspend Burst	Current	H	X	X	X	H	H	L	X	X	X	↑	DIN

NOTES:

1. L = V_{IL} , H = V_{IH} , X = Don't Care.
2. ZZ = LOW for this table.
3. \overline{OE} is an asynchronous input.

3780 tbl 07

Synchronous Write Function Truth Table⁽¹⁾

Operation	\overline{GW}	\overline{BWE}	BW_1	BW_2	BW_3	BW_4
Read	H	H	X	X	X	X
Read	H	L	H	H	H	H
Write all Bytes	L	X	X	X	X	X
Write all Bytes	H	L	L	L	L	L
Write Byte 1 ⁽²⁾	H	L	L	H	H	H
Write Byte 2 ⁽²⁾	H	L	H	L	H	H
Write Byte 3 ⁽²⁾	H	L	H	H	L	H
Write Byte 4 ⁽²⁾	H	L	H	H	H	L

3780 tbl 08

NOTES:

1. L = V_{IL} , H = V_{IH} , X = Don't Care.
2. Multiple bytes may be selected during the same cycle.

Asynchronous Truth Table⁽¹⁾

Operation	\overline{OE}	\overline{ZZ}	I/O Status	Power
Read	L	L	Data Out (I/O ₀ –I/O ₃₁)	Active
Read	H	L	High-Z	Active
Write	X	L	High-Z — Data In (I/O ₀ –I/O ₃₁)	Active
Deselected	X	L	High-Z	Standby
Sleep Mode	X	H	High-Z	Sleep

3780 tbl 09

NOTES:

1. L = V_{IL} , H = V_{IH} , X = Don't Care.
2. Synchronous function pins must be biased appropriately to satisfy operation requirements.

Interleaved Burst Sequence Table ($\overline{LBO}=V_{DD}$)

	Sequence 1		Sequence 2		Sequence 3		Sequence 4	
	A1	A0	A1	A0	A1	A0	A1	A0
First Address	0	0	0	1	1	0	1	1
Second Address	0	1	0	0	1	1	1	0
Third Address	1	0	1	1	0	0	0	1
Fourth Address ⁽¹⁾	1	1	1	0	0	1	0	0

3780 tbl 10

NOTE:

1. Upon completion of the Burst sequence the counter wraps around to its initial state.

Linear Burst Sequence Table ($\overline{LBO}=V_{SS}$)

	Sequence 1		Sequence 2		Sequence 3		Sequence 4	
	A1	A0	A1	A0	A1	A0	A1	A0
First Address	0	0	0	1	1	0	1	1
Second Address	0	1	1	0	1	1	0	0
Third Address	1	0	1	1	0	0	0	1
Fourth Address ⁽¹⁾	1	1	0	0	0	1	1	0

3780 tbl 11

NOTE:

1. Upon completion of the Burst sequence the counter wraps around to its initial state.

DC Electrical Characteristics Over the Operating Temperature and Supply Voltage Range (V_{DD} = 3.3V +10/-5%)

Symbol	Parameter	Test Conditions	Min.	Max.	Unit
I _{LI}	Input Leakage Current	V _{DD} = Max., V _{IN} = 0V to V _{DD}	—	5	μA
I _{LI}	ZZ & $\overline{\text{LBO}}$ Input Leakage Current ⁽¹⁾	V _{DD} = Max., V _{IN} = 0V to V _{DD}	—	30	μA
I _{LO}	Output Leakage Current	$\overline{\text{CE}} \geq V_{IH}$ or $\overline{\text{OE}} \geq V_{IH}$, V _{OUT} = 0V to V _{DD} , V _{DD} = Max.	—	5	μA
V _{OL}	Output Low Voltage	I _{OL} = 5mA, V _{DD} = Min.	—	0.4	V
V _{OH}	Output High Voltage	I _{OH} = -5mA, V _{DD} = Min.	2.4	—	V

3780 tbl 12

NOTE:

1. The $\overline{\text{LBO}}$ pin will be internally pulled to V_{DD} if it is not actively driven in the application and the ZZ pin will be internally pulled to V_{SS} if not actively driven.

DC Electrical Characteristics Over the Operating Temperature and Supply Voltage Range⁽¹⁾ (V_{HD} = V_{DDQ} - 0.2V, V_{LD} = 0.2V)

Symbol	Parameter	Test Conditions	IDT71V633S11 ⁽³⁾		IDT71V633S12		Unit
			Com'l	Ind'l	Com'l	Ind'l	
I _{DD}	Operating Core Power Supply Current	Device Selected, Outputs Open, V _{DD} = Max., V _{DDQ} = Max., V _{IN} ≥ V _{IH} or ≤ V _{IL} , f = f _{MAX} ⁽²⁾	160	—	150	150	mA
I _{SB}	Standby Core Power Supply Current	Device Deselected, Outputs Open, V _{DD} = Max., V _{DDQ} = Max., V _{IN} ≥ V _{IH} or ≤ V _{IL} , f = f _{MAX} ⁽²⁾	45	—	40	40	mA
I _{SB1}	Full Standby Core Power Supply Current	Device Deselected, Outputs Open, V _{DD} = Max., V _{DDQ} = Max., V _{IN} ≥ V _{HD} or ≤ V _{LD} , f = 0 ⁽²⁾	15	—	15	15	mA
I _{ZZ}	Full Sleep Mode Core Power Supply Current	ZZ ≥ V _{HD} , V _{DD} = Max.	15	—	15	15	mA

3780 tbl 13

NOTES:

- All values are maximum guaranteed values.
- At f = f_{MAX}, inputs are cycling at the maximum frequency of read cycles of 1/t_{cy} while $\overline{\text{ADSC}}$ = LOW; f=0 means no input lines are changing.
- 0°C to +70°C temperature range only.

AC Test Loads

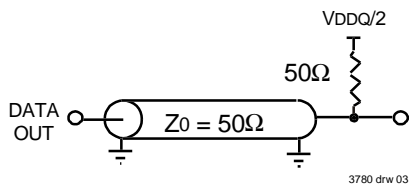
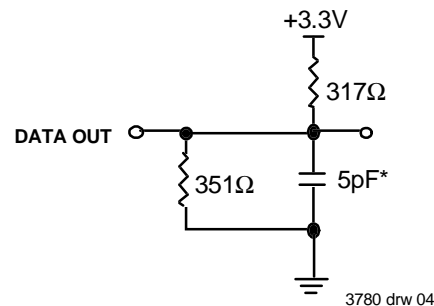

Figure 1. AC Test Load



* Including scope and jig capacitance.

Figure 2. High-Impedance Test Load (for t_{OHZ}, t_{CHZ}, t_{OLZ}, and t_{DC1})

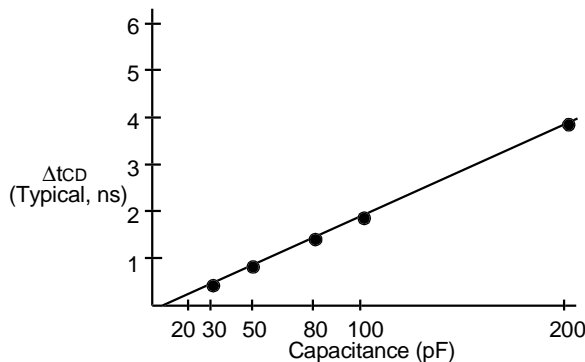

Figure 3. Lumped Capacitive Load, Typical Derating

AC Test Conditions

Input Pulse Levels	0 to 3.0V
Input Rise/Fall Times	2ns
Input Timing Reference Levels	1.5V
Output Timing Reference Levels	1.5V
AC Test Load	See Figures 1 and 2

3780 tbl 14

AC Electrical Characteristics (VDD = 3.3V +10/-5%, Commercial and Industrial Temperature Ranges)

Symbol	Parameter	71V633S11 ⁽⁶⁾		71V633S12		Unit
		Min.	Max.	Min.	Max.	
Clock Parameters						
t _{CYC}	Clock Cycle Time	20	—	20	—	ns
t _{CH} ⁽¹⁾	Clock High Pulse Width	6	—	6	—	ns
t _{CL} ⁽¹⁾	Clock Low Pulse Width	6	—	6	—	ns
Output Parameters						
t _{CD}	Clock High to Valid Data	—	11	—	12	ns
t _{CDC}	Clock High to Data Change	3	—	3	—	ns
t _{CLZ} ⁽²⁾	Clock High to Output Active	0	—	0	—	ns
t _{CHZ} ⁽²⁾	Clock High to Data High-Z	3	6	3	6	ns
t _{OE}	Output Enable Access Time	—	4	—	4	ns
t _{OLZ} ⁽²⁾	Output Enable Low to Data Active	0	—	0	—	ns
t _{OHZ} ⁽²⁾	Output Enable High to Data High-Z	—	6	—	6	ns
Setup Times						
t _{SA}	Address Setup Time	2.5	—	2.5	—	ns
t _{SS}	Address Status Setup Time	2.5	—	2.5	—	ns
t _{SD}	Data in Setup Time	2.5	—	2.5	—	ns
t _{SW}	Write Setup Time	2.5	—	2.5	—	ns
t _{SAV}	Address Advance Setup Time	2.5	—	2.5	—	ns
t _{SC}	Chip Enable/Select Setup Time	2.5	—	2.5	—	ns
Hold Times						
t _{HA}	Address Hold Time	0.5	—	0.5	—	ns
t _{HS}	Address Status Hold Time	0.5	—	0.5	—	ns
t _{HD}	Data In Hold Time	0.5	—	0.5	—	ns
t _{HW}	Write Hold Time	0.5	—	0.5	—	ns
t _{HAV}	Address Advance Hold Time	0.5	—	0.5	—	ns
t _{HC}	Chip Enable/Select Hold Time	0.5	—	0.5	—	ns
Sleep Mode and Configuration Parameters						
t _{ZZPW}	ZZ Pulse Width	100	—	100	—	ns
t _{ZZR} ⁽³⁾	ZZ Recovery Time	100	—	100	—	ns
t _{CFG} ⁽⁴⁾	Configuration Set-up Time	80	—	80	—	ns

3780 tbl 15

NOTES:

1. Measured as HIGH above 2.0V and LOW below 0.8V.
2. Transition is measured ±200mV from steady-state.
3. Device must be deselected when powered-up from sleep mode.
4. t_{CFG} is the minimum time required to configure the device based on the $\overline{\text{LBO}}$ input. $\overline{\text{LBO}}$ is a static input and must not change during normal operation.
5. 0°C to +70°C temperature range only.

Timing Waveform of Read Cycle^(1,2)

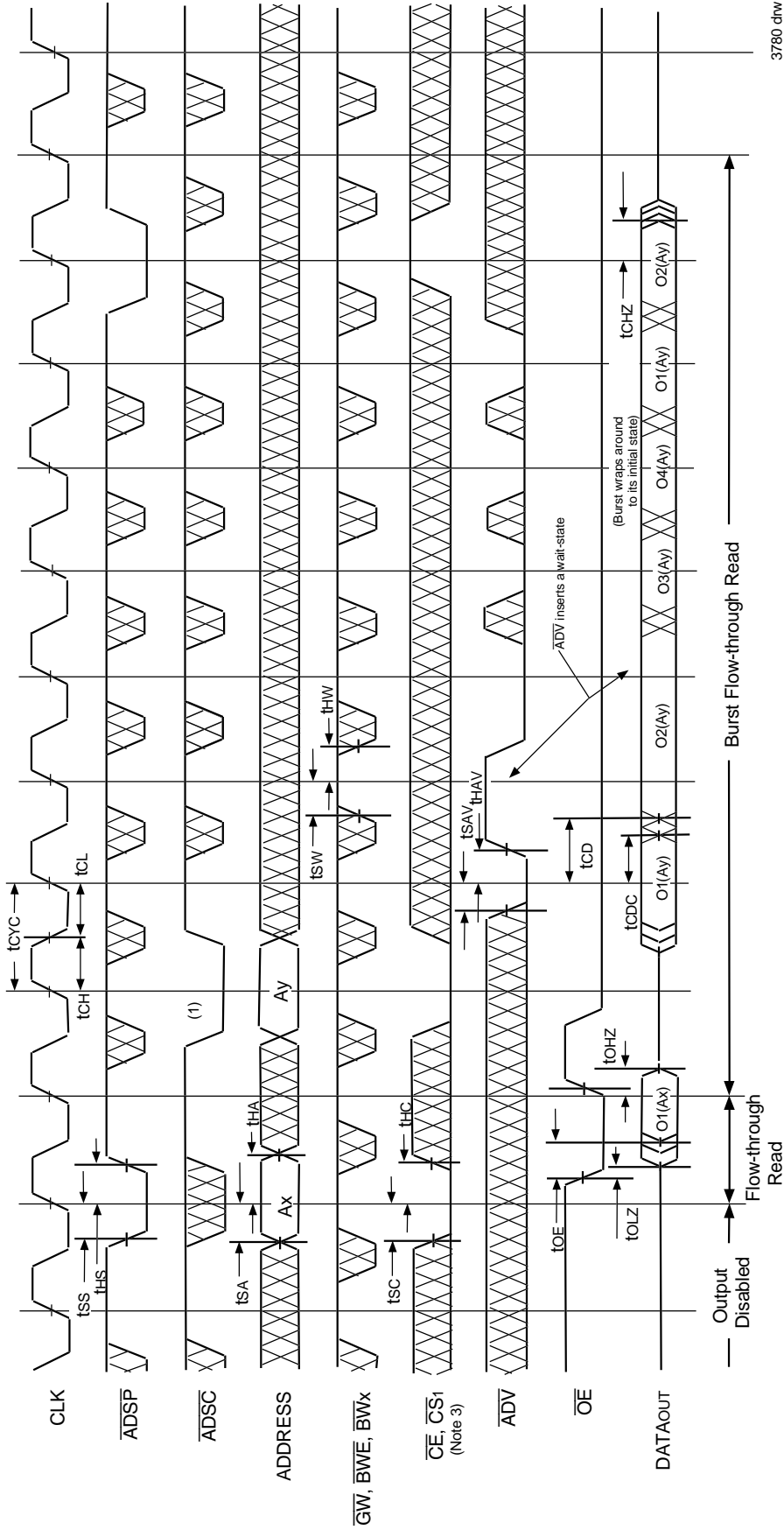

3780 dnw.06

NOTES:

1. O1 (Ax) represents the first output from the external address Ax. O1 (Ay) represents the first output from the external address Ay; O2 (Ay) represents the next output data in the burst sequence of the base address Ay, etc., where A0 and A1 are advancing for the four word burst in the sequence defined by the state of the LBO input.
2. ZZ input is LOW and LBO is Don't Care for this cycle.
3. CS0 timing transitions are identical but inverted to the CE and CS1 signals. For example, when CE and CS1 are LOW on this waveform, CS0 is HIGH.

Timing Waveform of Combined Read and Write Cycles^(1,2,3)

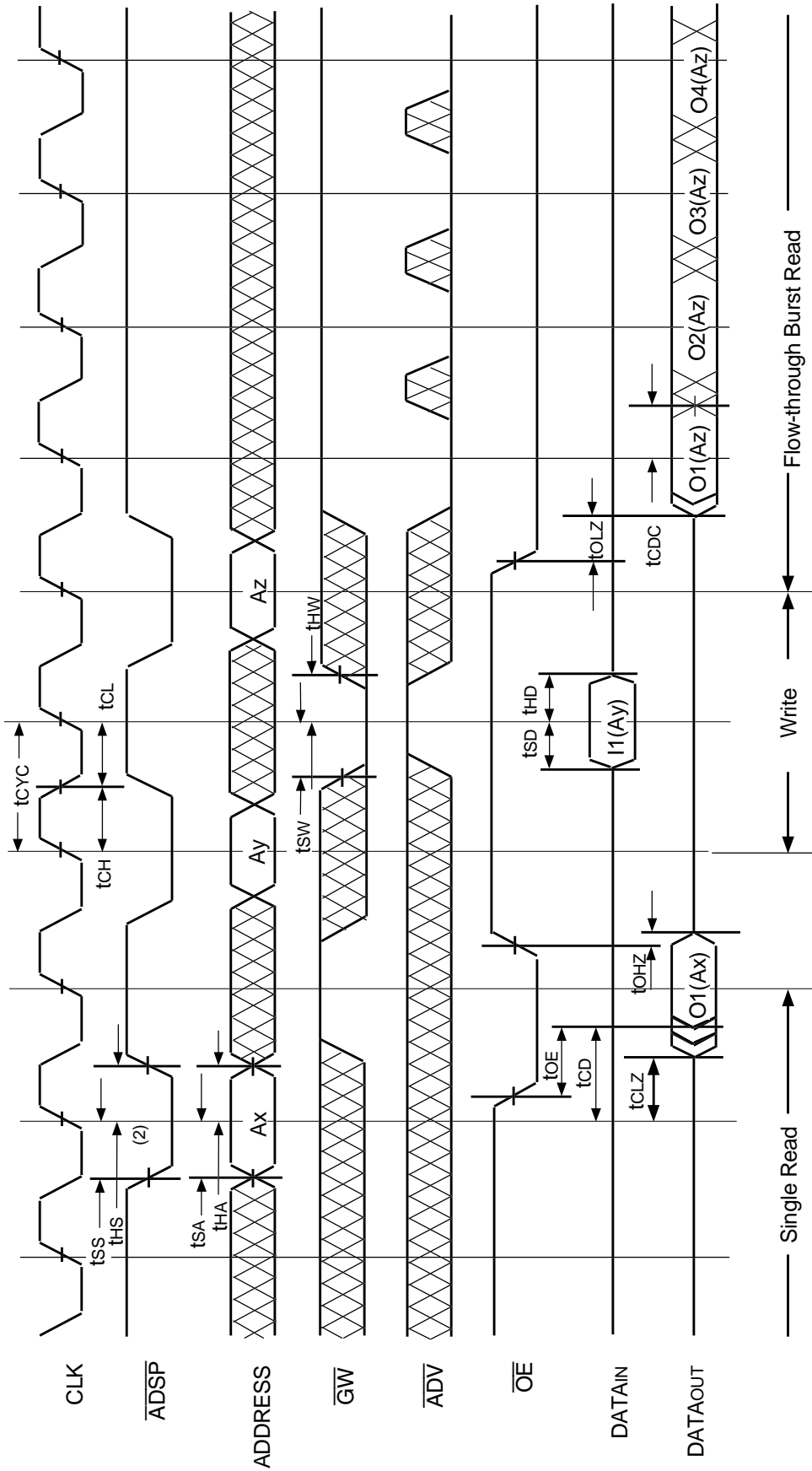

3780 drw 07

NOTES:

1. Device is selected through entire cycle; \overline{CE} and $\overline{CS1}$ are LOW, $\overline{CS0}$ is HIGH.
2. ZZ input is LOW and LBO is Don't Care for this cycle.
3. O1 (Ax) represents the first output from the external address Ax. I1 (Ay) represents the first input from the external address Ay. O1 (Az) represents the first output from the external address Az. O2 (Az) represents the next output data in the burst sequence of the base address Az, etc., where A0 and A1 are advancing for the four word burst in the sequence defined by the state of the LBO input.

Timing Waveform of Write Cycle No. 1 — $\overline{\text{GW}}$ Controlled^(1,2,3)

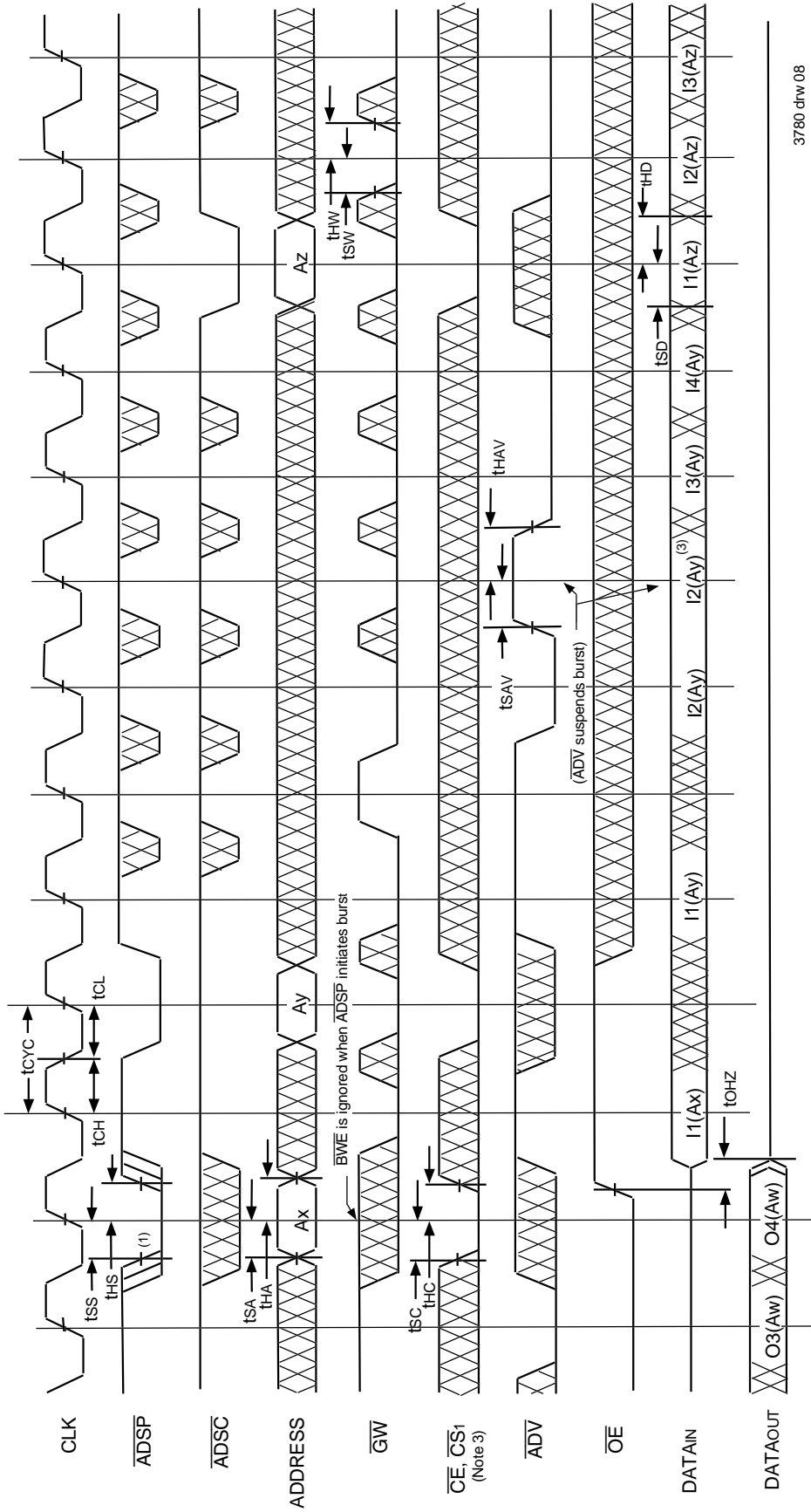

3780 drw 08

NOTES:

1. Z₀ input is LOW, $\overline{\text{BWE}}$ is HIGH, and $\overline{\text{LBO}}$ is Don't Care for this cycle.
2. O4 (Aw) represents the final output data in the burst sequence of the base address Aw. I1 (Ay) represents the first input from the external address Ay. I2 (Ay) represents the next input data in the burst sequence of the base address Ay, etc., where Ao and Ai are advancing for the four word burst in the sequence defined by the state of the LBO input. In the case of input I2(Ay) this data is valid for two cycles because $\overline{\text{ADV}}$ is high and has suspended the burst.
3. CS₀ timing transitions are identical but inverted to the CE and CS₁ signals. For example, when CE and CS₁ are LOW on this waveform, CS₀ is HIGH.

Timing Waveform of Write Cycle No. 2 — Byte Controlled^(1,2,3)

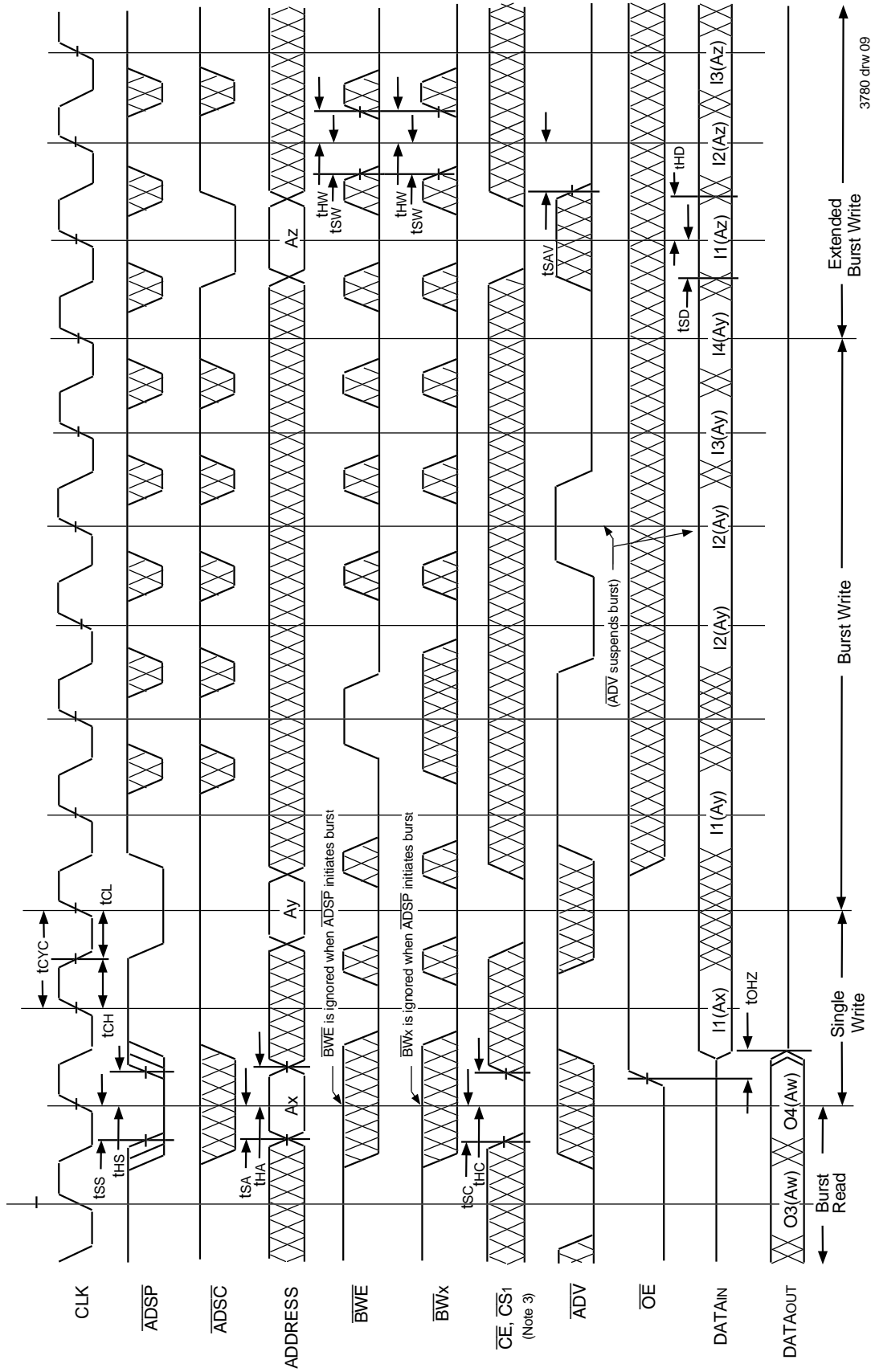

NOTES:

1. Z₀ input is LOW, $\overline{G\!W}$ is HIGH, and $\overline{L\!B\!O}$ is Don't Care for this cycle.
2. O₄ (Aw) represents the final output data in the burst sequence of the base address Aw. 11 (Ax) represents the first input from the external address Ax. 11 (Ay) represents the first input from the external address Ay. etc., where A₀ and A₁ are advancing in the sequence defined by the state of the LBO input. In the case of input 12(Ay) this data is valid for two cycles because \overline{ADV} is high and has suspended the burst.
3. CS₀ timing transitions are identical but inverted to the \overline{CE} and $\overline{CS_1}$ signals. For example, when \overline{CE} and $\overline{CS_1}$ are LOW on this waveform, CS₀ is HIGH.

3780 drw 09

Timing Waveform of Sleep (ZZ) and Power-Down Modes^(1,2,3)

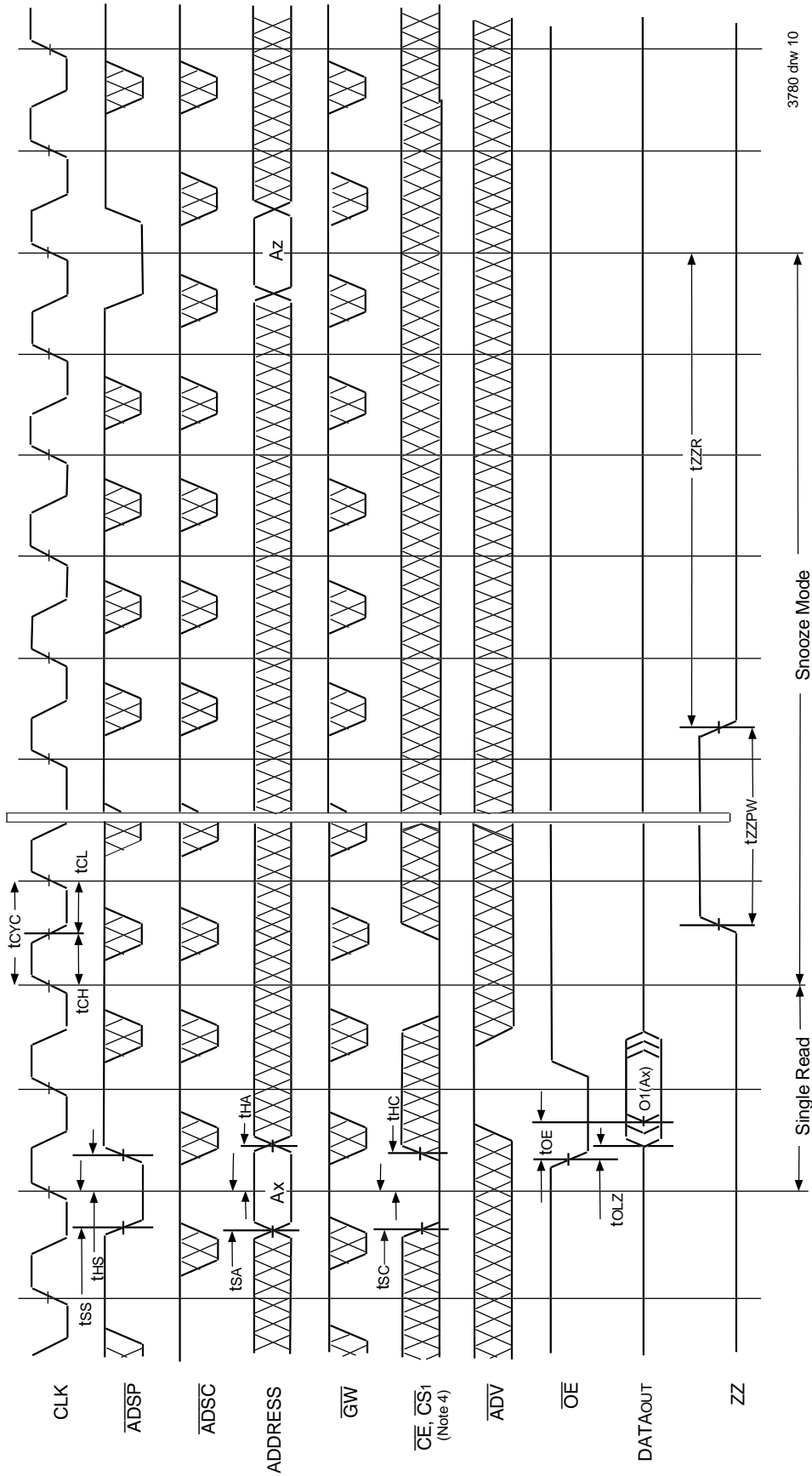

3780 dhw 10

NOTES:

1. Device must power up in deselected mode.
2. LBO input is Don't Care for this cycle.
3. It is not necessary to retain the state of the input registers throughout the Power-down cycle.
4. CS0 timing transitions are identical but inverted to the CE and CS1 signals. For example, when \overline{CE} and $\overline{CS1}$ are LOW on this waveform, CS0 is HIGH.

Non-Burst Read Cycle Timing Waveform

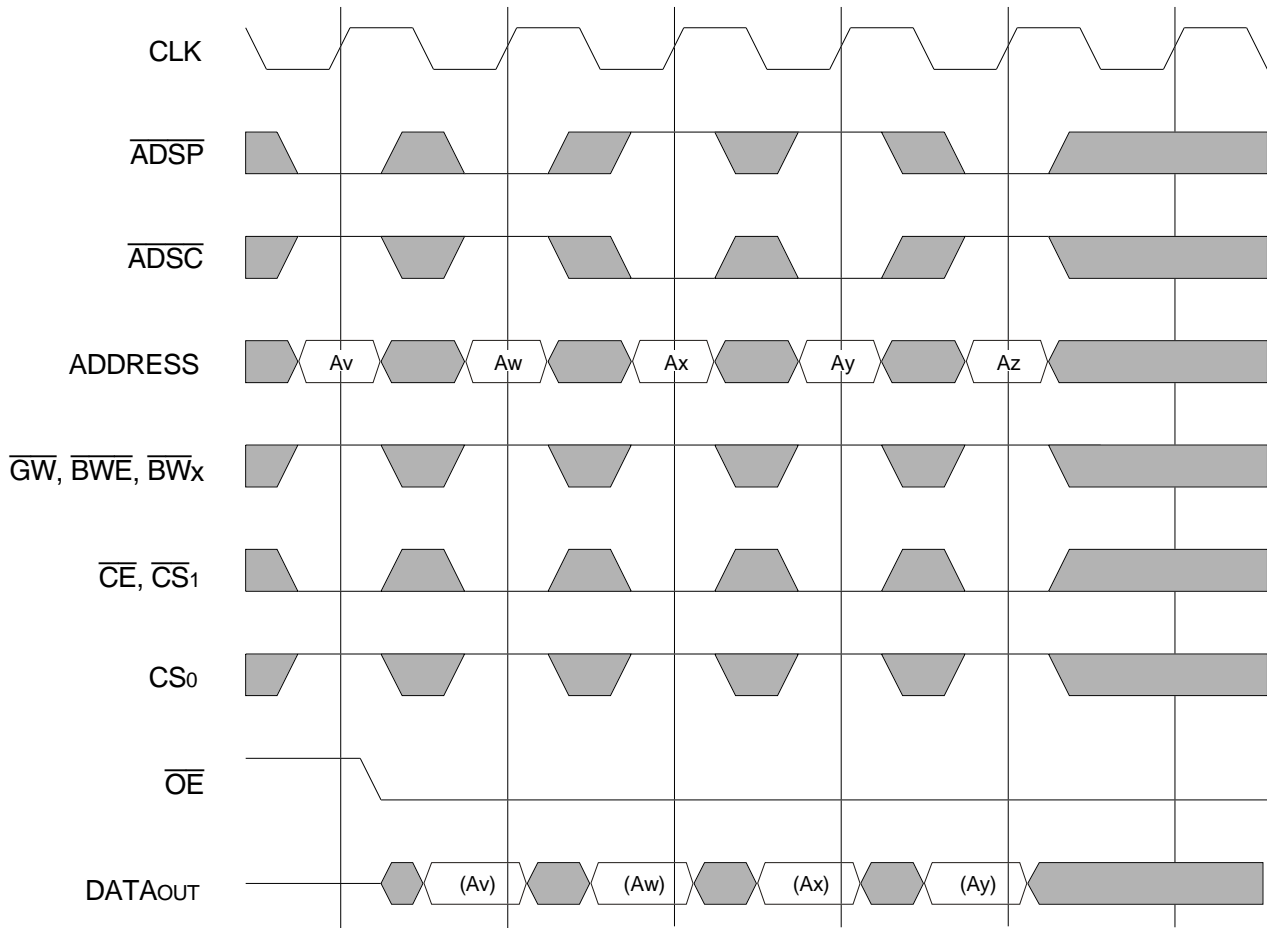

3780 drw 11

NOTES:

1. ZZ input is LOW, \overline{ADV} is HIGH, and \overline{LBO} is Don't Care for this cycle.
2. (Ax) represents the data for address Ax, etc.
3. For read cycles, \overline{ADSP} and \overline{ADSC} function identically and are therefore interchangeable.

Non-Burst Write Cycle Timing Waveform

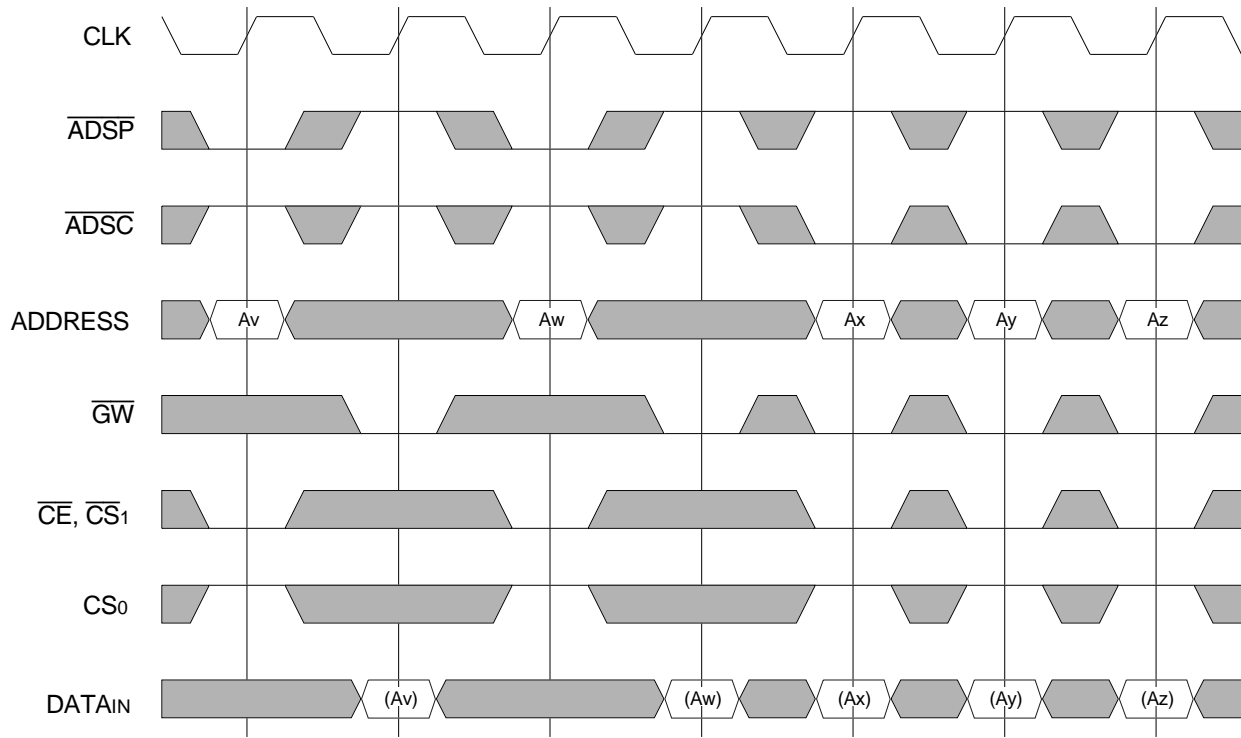

3780 drw 12

NOTES:

1. \overline{ZZ} input is LOW, \overline{ADV} and \overline{OE} are HIGH, and \overline{LBO} is Don't Care for this cycle.
2. (A_x) represents the data for address A_x , etc.
3. Although only \overline{GW} writes are shown, the functionality of \overline{BWE} and \overline{BWx} together is the same as \overline{GW} .
4. For write cycles, \overline{ADSP} and \overline{ADSC} have different limitations.

100-pin Thin Quad Plastic Flatpack (TQFP) Package Diagram Outline

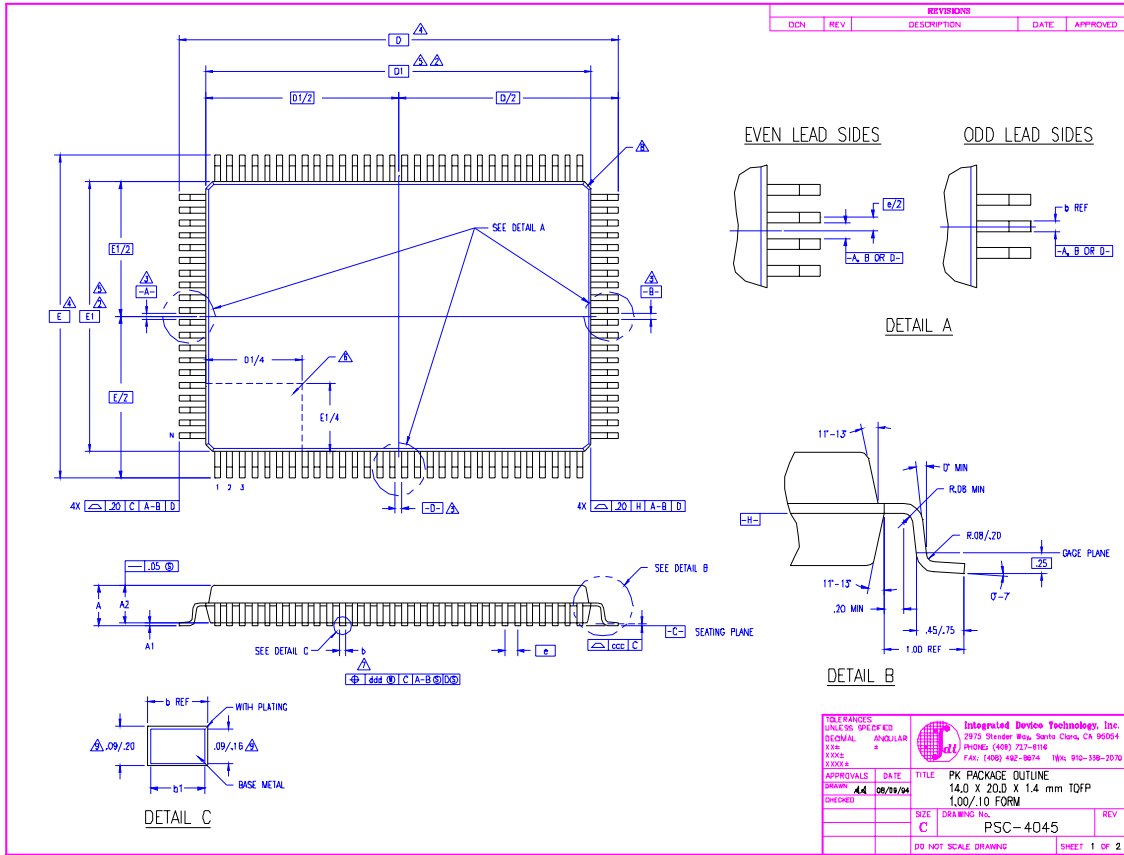

TOLERANCES
UNLESS SPECIFIED

DECIMAL ANGULAR
XXX °

INTEGRATED DEVICE TECHNOLOGY, INC.
2975 Shender Way, Santa Clara, CA 95054
PHONE: (408) 727-6116
FAX: (408) 492-8674 TEL: 910-358-2070

APPROVALS DATE TITLE
DRAWN AA 06/29/94 PK PACKAGE OUTLINE
CHECKED 14.0 X 20.0 X 1.4 mm TQFP
1.00/.10 FORM

SIZE DRAWING NO. REV
C PSC-4045

DO NOT SCALE DRAWING SHEET 1 OF 2

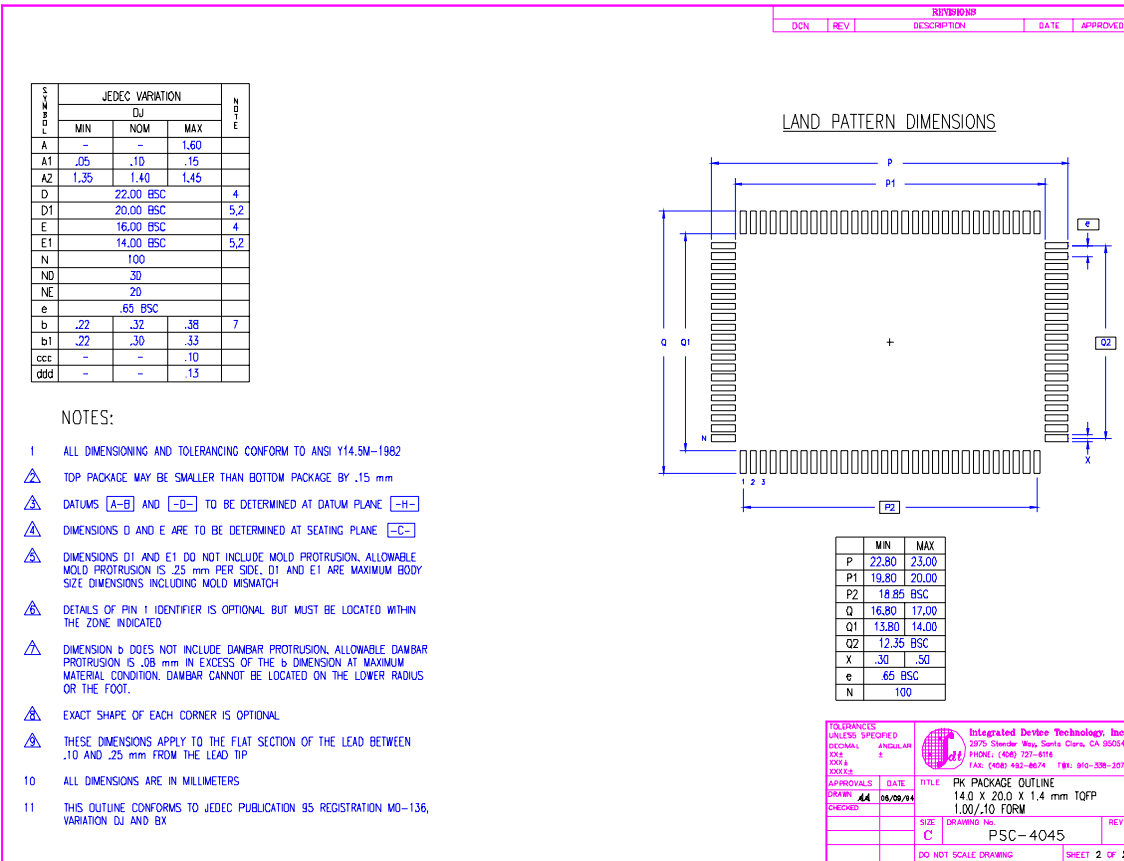

Datasheet Document History

9/9/99		Updated to new format
	Pg. 6-8	Reordered pages, updated notes
	Pg. 10-14	Updated notes
	Pg. 18	Added Datasheet Document History
9/30/99	Pg. 1, 4, 8, 9, 17	Added Industrial temperature range offering
10/8/99	Pg. 1	Corrected -12 speed
04/04/00	Pg. 17	Added 100pinTQFP Package Diagram Outline
08/09/00		Not recommended for new designs
08/17/01		Removed "Not recommended for new designs" from the background on the datasheet



CORPORATE HEADQUARTERS

2975 Stender Way
Santa Clara, CA 95054

for SALES:

800-345-7015 or 408-727-6116
fax: 408 492-8674
www.idt.com

for TECH SUPPORT:

sramhelp@idt.com
800 544-7726, x4033

The IDT logo is a registered trademark of Integrated Device Technology, Inc.



LittleDiode supplies new, hard to find or obsolete electronic components and semiconductors all over the world.

With over two million different components listed you are sure to find the part you need.

Feel free to visit us today at our online store:

LittleDiode.com

Looking forward to providing you with the best possible service.