



# FAST CMOS 16-BIT BUFFER/LINE DRIVER

## IDT74FCT162240AT/CT

### FEATURES:

- 0.5 MICRON CMOS Technology
- High-speed, low-power CMOS replacement for ABT functions
- Typical  $t_{sk(o)}$  (Output Skew) < 250ps
- Low input and output leakage  $\leq 1\mu A$  (max.)
- ESD > 2000V per MIL-STD-883, Method 3015; > 200V using machine model (C = 200pF, R = 0)
- $V_{CC} = 5V \pm 10\%$
- Balanced Output Drivers:  $\pm 24mA$
- Reduced system switching noise
- Typical  $V_{OLP}$  (Output Ground Bounce) < 0.6V at  $V_{CC} = 5V$ ,  $T_A = 25^\circ C$
- Available in SSOP and TSSOP packages

### DESCRIPTION:

The FCT162240T 16-bit buffer/line driver is built using advanced dual metal CMOS technology. These high-speed, low-power devices offer bus/backplane interface capability with improved packing density. The flow-through organization of signal pins simplifies layout. The three-state controls are designed to operate these devices in a Quad-Nibble, Dual-Byte or single 16-bit word mode. All inputs are designed with hysteresis for improved noise margin.

The FCT162240T have balanced output drive with current limiting resistors. This offers low ground bounce, minimal undershoot, and controlled output fall times—reducing the need for external series terminating resistors. The FCT162240T is a plug-in replacement for FCT16240T and 74ABT16240 for on-board interface applications.

### FUNCTIONAL BLOCK DIAGRAM

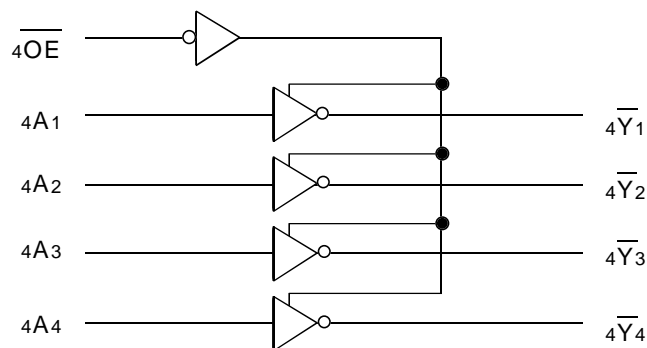
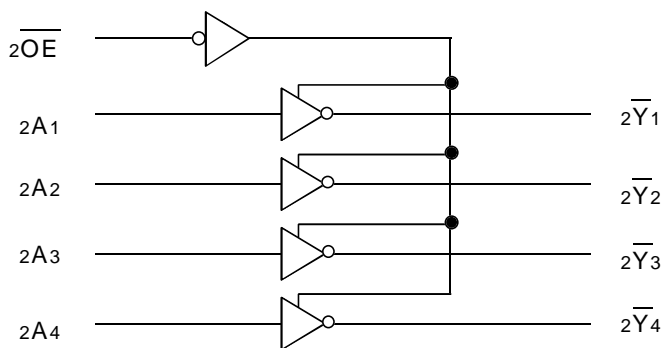
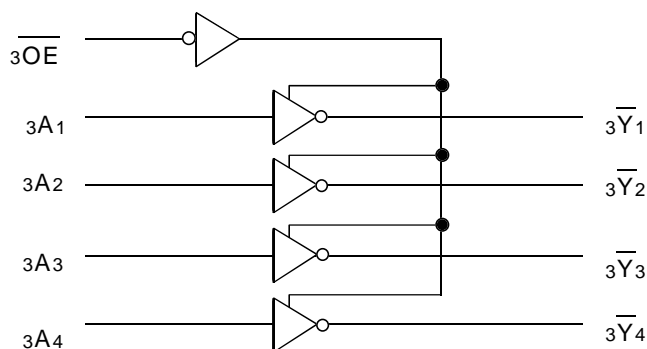
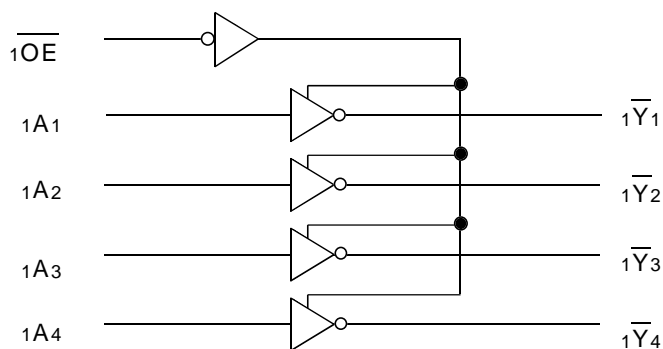

The IDT logo is a registered trademark of Integrated Device Technology, Inc.

**INDUSTRIAL TEMPERATURE RANGE**

**APRIL 2002**

## PIN CONFIGURATION

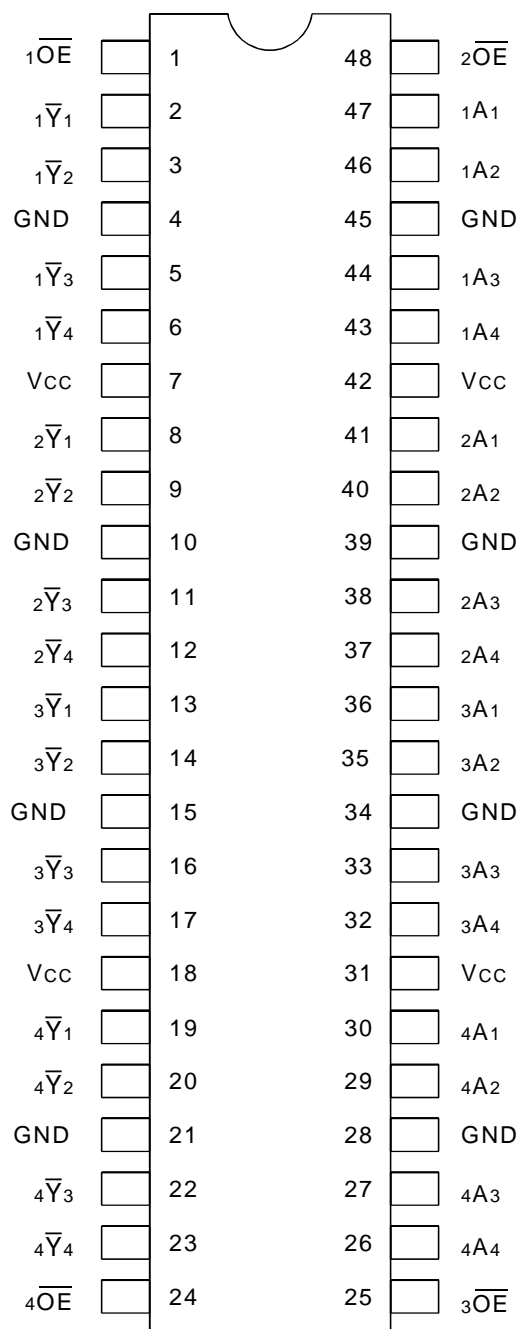

SSOP/ TSSOP  
TOP VIEW

## ABSOLUTE MAXIMUM RATINGS<sup>(1)</sup>

Symbol	Description	Max	Unit
V <sub>TERM</sub> <sup>(2)</sup>	Terminal Voltage with Respect to GND	-0.5 to +7	V
V <sub>TERM</sub> <sup>(3)</sup>	Terminal Voltage with Respect to GND	-0.5 to V <sub>CC</sub> +0.5	V
T <sub>STG</sub>	Storage Temperature	-65 to +150	°C
I <sub>OUT</sub>	DC Output Current	-60 to +120	mA

### NOTES:

- Stresses greater than those listed under ABSOLUTE MAXIMUM RATINGS may cause permanent damage to the device. This is a stress rating only and functional operation of the device at these or any other conditions above those indicated in the operational sections of this specification is not implied. Exposure to absolute maximum rating conditions for extended periods may affect reliability.
- All device terminals except FCT162XXX Output and I/O terminals.
- Output and I/O terminals terminals for FCT162XXX.

## CAPACITANCE (T<sub>A</sub> = +25°C, F = 1.0MHz)

Symbol	Parameter <sup>(1)</sup>	Conditions	Typ.	Max.	Unit
C <sub>IN</sub>	Input Capacitance	V <sub>IN</sub> = 0V	3.5	6	pF
C <sub>OUT</sub>	Output Capacitance	V <sub>OUT</sub> = 0V	3.5	8	pF

### NOTE:

- This parameter is measured at characterization but not tested.

## PIN DESCRIPTION

Pin Names	Description
x $\overline{OE}$	3-State Output Enable Inputs (Active LOW)
xAx	Data Inputs
x $\overline{Y}$ x	3-State Outputs

## FUNCTION TABLE<sup>(1)</sup>

Inputs		Outputs
x $\overline{OE}$	xAx	x $\overline{Y}$ x
L	L	H
L	H	L
H	X	Z

### NOTE:

- H = HIGH Voltage Level  
X = Don't Care  
L = LOW Voltage Level  
Z = High-Impedance

## DC ELECTRICAL CHARACTERISTICS OVER OPERATING RANGE

Following Conditions Apply Unless Otherwise Specified:

Industrial:  $T_A = -40^{\circ}\text{C}$  to  $+85^{\circ}\text{C}$ ,  $V_{CC} = 5.0\text{V} \pm 10\%$

Symbol	Parameter	Test Conditions <sup>(1)</sup>		Min.	Typ. <sup>(2)</sup>	Max.	Unit
$V_{IH}$	Input HIGH Level	Guaranteed Logic HIGH Level		2	—	—	V
$V_{IL}$	Input LOW Level	Guaranteed Logic LOW Level		—	—	0.8	V
$I_{IH}$	Input HIGH Current (Input pins) <sup>(5)</sup>	$V_{CC} = \text{Max.}$	$V_i = V_{CC}$	—	—	$\pm 1$	$\mu\text{A}$
	Input HIGH Current (I/O pins) <sup>(5)</sup>			—	—	$\pm 1$	
$I_{IL}$	Input LOW Current (Input pins) <sup>(5)</sup>		$V_i = \text{GND}$	—	—	$\pm 1$	
	Input LOW Current (I/O pins) <sup>(5)</sup>			—	—	$\pm 1$	
$I_{OZH}$	High Impedance Output Current (3-State Output pins) <sup>(5)</sup>	$V_{CC} = \text{Max.}$	$V_o = 2.7\text{V}$	—	—	$\pm 1$	$\mu\text{A}$
$I_{OZL}$			$V_o = 0.5\text{V}$	—	—	$\pm 1$	
$V_{IK}$	Clamp Diode Voltage	$V_{CC} = \text{Min.}, I_{IN} = -18\text{mA}$		—	-0.7	-1.2	V
$I_{OS}$	Short Circuit Current	$V_{CC} = \text{Max.}, V_o = \text{GND}^{(3)}$		-80	-140	-250	mA
$V_H$	Input Hysteresis	—		—	100	—	mV
$I_{CCL}$ $I_{CCH}$ $I_{CCZ}$	Quiescent Power Supply Current	$V_{CC} = \text{Max.}$ $V_{IN} = \text{GND or } V_{CC}$		—	5	500	$\mu\text{A}$

## OUTPUT DRIVE CHARACTERISTICS

Symbol	Parameter	Test Conditions <sup>(1)</sup>		Min.	Typ. <sup>(2)</sup>	Max.	Unit
$I_{ODL}$	Output LOW Current	$V_{CC} = 5\text{V}, V_{IN} = V_{IH} \text{ or } V_{IL}, V_o = 1.5\text{V}^{(3)}$		60	115	200	mA
$I_{ODH}$	Output HIGH Current	$V_{CC} = 5\text{V}, V_{IN} = V_{IH} \text{ or } V_{IL}, V_o = 1.5\text{V}^{(3)}$		-60	-115	-200	mA
$V_{OH}$	Output HIGH Voltage	$V_{CC} = \text{Min}$ $V_{IN} = V_{IH} \text{ or } V_{IL}$	$I_{OH} = -24\text{mA}$	2.4	3.3	—	V
$V_{OL}$	Output LOW Voltage	$V_{CC} = \text{Min}$ $V_{IN} = V_{IH} \text{ or } V_{IL}$	$I_{OH} = 24\text{mA}$	—	0.3	0.55	V

### NOTES:

1. For conditions shown as Min. or Max., use appropriate value specified under Electrical Characteristics for the applicable device type.
2. Typical values are at  $V_{CC} = 5.0\text{V}$ ,  $+25^{\circ}\text{C}$  ambient.
3. Not more than one output should be tested at one time. Duration of the test should not exceed one second.
4. Duration of the condition can not exceed one second.
5. This test limit for this parameter is  $\pm 5\mu\text{A}$  at  $T_A = -55^{\circ}\text{C}$ .

## POWER SUPPLY CHARACTERISTICS

Symbol	Parameter	Test Conditions <sup>(1)</sup>		Min.	Typ. <sup>(2)</sup>	Max.	Unit
$\Delta I_{CC}$	Quiescent Power Supply Current TTL Inputs HIGH	$V_{CC} = \text{Max.}$ $V_{IN} = 3.4V^{(3)}$		—	0.5	1.5	mA
$I_{CCD}$	Dynamic Power Supply Current <sup>(4)</sup>	$V_{CC} = \text{Max.}$ Outputs Open $\overline{xOE} = \text{GND}$ One Input Toggling 50% Duty Cycle	$V_{IN} = V_{CC}$ $V_{IN} = \text{GND}$	—	60	100	$\mu\text{A}/\text{MHz}$
$I_C$	Total Power Supply Current <sup>(6)</sup>	$V_{CC} = \text{Max.}$ Outputs Open $f_i = 10\text{MHz}$ 50% Duty Cycle $\overline{xOE} = \text{GND}$ One Bit Toggling	$V_{IN} = V_{CC}$ $V_{IN} = \text{GND}$	—	0.6	1.5	mA
			$V_{IN} = 3.4V$ $V_{IN} = \text{GND}$	—	0.9	2.3	
		$V_{CC} = \text{Max.}$ Outputs Open $f_i = 2.5\text{MHz}$ 50% Duty Cycle $\overline{xOE} = \text{GND}$ Sixteen Bits Toggling	$V_{IN} = V_{CC}$ $V_{IN} = \text{GND}$	—	2.4	4.5 <sup>(5)</sup>	
			$V_{IN} = 3.4V$ $V_{IN} = \text{GND}$	—	6.4	16.5 <sup>(5)</sup>	

### NOTES:

- For conditions shown as Min. or Max., use appropriate value specified under Electrical Characteristics for the applicable device type.
- Typical values are at  $V_{CC} = 5.0V$ ,  $+25^\circ\text{C}$  ambient.
- Per TTL driven input; ( $V_{IN} = 3.4V$ ). All other inputs at  $V_{CC}$  or GND.
- This parameter is not directly testable, but is derived for use in Total Power Supply Calculations.
- Values for these conditions are examples of the  $I_{CC}$  formula. These limits are guaranteed but not tested.
- $I_C = I_{QUIESCENT} + I_{INPUTS} + I_{DYNAMIC}$   
 $I_C = I_{CC} + \Delta I_{CC} \cdot D_H \cdot N_T + I_{CCD} \cdot (f_{CP} \cdot N_{CP} / 2 + f_i \cdot N_i)$   
 $I_{CC} = \text{Quiescent Current (} I_{CCL}, I_{CCH} \text{ and } I_{CCZ} \text{)}$   
 $\Delta I_{CC} = \text{Power Supply Current for a TTL High Input (} V_{IN} = 3.4V \text{)}$   
 $D_H = \text{Duty Cycle for TTL Inputs High}$   
 $N_T = \text{Number of TTL Inputs at } D_H$   
 $I_{CCD} = \text{Dynamic Current caused by an Input Transition Pair (HLH or LHL)}$   
 $f_{CP} = \text{Clock Frequency for Register Devices (Zero for Non-Register Devices)}$   
 $N_{CP} = \text{Number of Clock Inputs at } f_{CP}$   
 $f_i = \text{Input Frequency}$   
 $N_i = \text{Number of Inputs at } f_i$

## SWITCHING CHARACTERISTICS OVER OPERATING RANGE

Symbol	Parameter	Condition <sup>(1)</sup>	FCT162240AT		FCT162240CT		Unit
			Min. <sup>(2)</sup>	Max.	Min. <sup>(2)</sup>	Max.	
$t_{PLH}$	Propagation Delay	$C_L = 50\text{pF}$ $R_L = 500\Omega$	1.5	4.8	1.5	3.4	ns
$t_{PHL}$	$xAx$ to $x\bar{Y}x$						
$t_{PZH}$	Output Enable Time		1.5	6.2	1.5	4.4	ns
$t_{PZL}$							
$t_{PHZ}$	Output Disable Time		1.5	5.6	1.5	4.1	ns
$t_{PLZ}$							
$t_{SK(o)}$	Output Skew <sup>(3)</sup>	—	0.5	—	0.5	ns	

### NOTES:

- See test circuit and waveforms.
- Minimum limits are guaranteed but not tested on Propagation Delays.
- Skew between any two outputs of the same package switching in the same direction. This parameter is guaranteed by design.

## TEST CIRCUITS AND WAVEFORMS

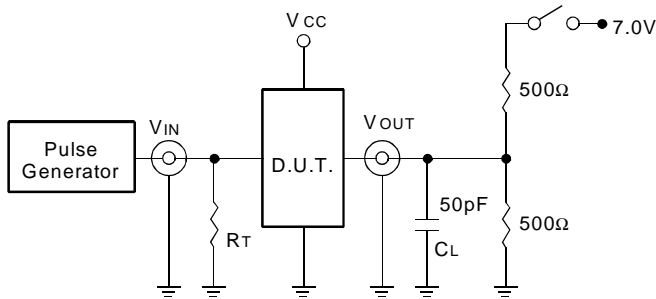

Test Circuits for All Outputs

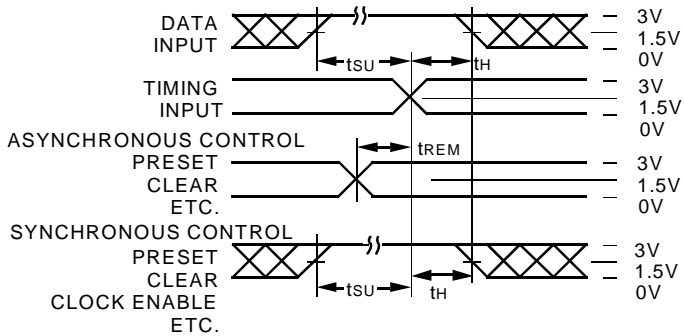

Set-Up, Hold, and Release Times

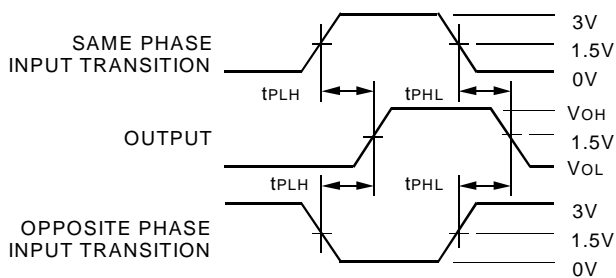

Propagation Delay

## SWITCH POSITION

Test	Switch
Open Drain Disable Low Enable Low	Closed
All Other Tests	Open

### DEFINITIONS:

$C_L$  = Load capacitance: includes jig and probe capacitance.  
 $R_T$  = Termination resistance: should be equal to  $Z_{out}$  of the Pulse Generator.

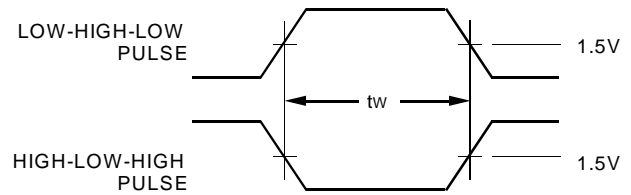

Pulse Width

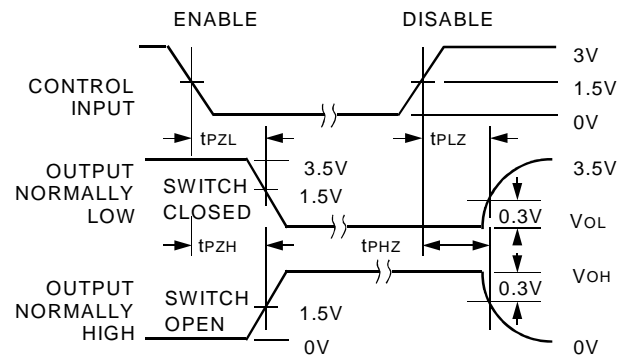

Enable and Disable Times

### NOTES:

- Diagram shown for input Control Enable-LOW and input Control Disable-HIGH.
- Pulse Generator for All Pulses: Rate  $\leq$  1.0MHz;  $t_r \leq$  2.5ns;  $t_f \leq$  2.5ns.

## ORDERING INFORMATION

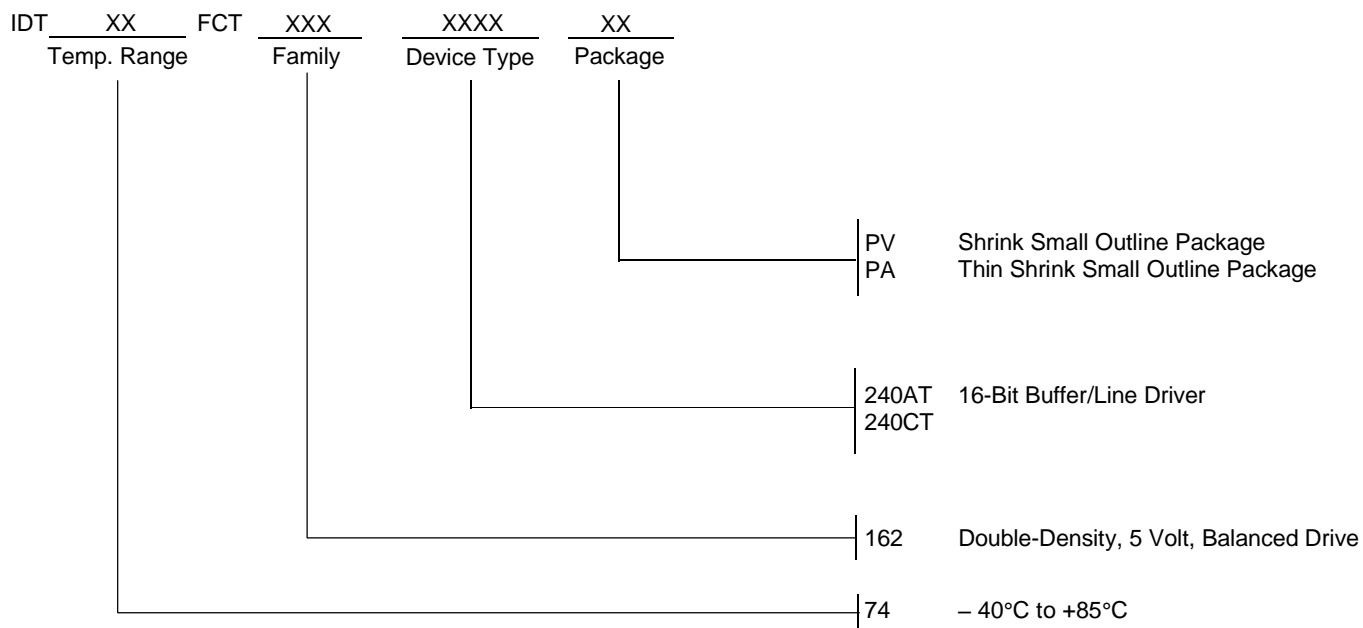

## DATA SHEET DOCUMENT HISTORY

3/26/2002 Removed standard speed grade



**CORPORATE HEADQUARTERS**  
2975 Stender Way  
Santa Clara, CA 95054

**for SALES:**  
800-345-7015 or 408-727-6116  
fax: 408-492-8674  
www.idt.com

**for Tech Support:**  
logichelp@idt.com  
(408) 654-6459



LittleDiode supplies new, hard to find or obsolete electronic components and semiconductors all over the world.

With over two million different components listed you are sure to find the part you need.

Feel free to visit us today at our online store:

[LittleDiode.com](http://LittleDiode.com)

Looking forward to providing you with the best possible service.