



FAST CMOS 16-BIT BUS TRANSCEIVER/ REGISTER (3-STATE)

IDT74FCT162646AT/CT

FEATURES:

- 0.5 MICRON CMOS Technology
- High-speed, low-power CMOS replacement for ABT functions
- Typical $t_{SK(o)}$ (Output Skew) < 250ps
- Low input and output leakage $-1\mu A$ (max.)
- ESD > 2000V per MIL-STD-883, Method 3015; > 200V using machine model (C = 200pF, R = 0)
- $V_{CC} = 5V \pm 10\%$
- Balanced Output Drivers ($\pm 24mA$)
- Reduced system switching noise
- Typical VOLP (Output Ground Bounce) < 1V at $V_{CC} = 5V$, $T_A = 25^\circ C$
- Available in SSOP, TSSOP, and TVSOP packages

DESCRIPTION:

The FCT162646T 16-bit registered transceivers are built using advanced dual metal CMOS technology. These high-speed, low-power devices are organized as two independent 8-bit bus transceivers with 3-state D-type registers. The control circuitry is organized for multiplexed transmission of data between A bus and B bus either directly or from the internal storage registers. Each 8-bit transceiver/register features direction control ($xDIR$), over-riding Output Enable control ($x\overline{OE}$) and Select lines ($xSAB$ and $xSBA$) to select either real-time data or stored data. Separate clock inputs are provided for A and B port registers. Data on the A or B data bus, or both, can be stored in the internal registers by the low-to-high transitions at the appropriate clock pins. Flow-through organization of signal pins simplifies layout. All inputs are designed with hysteresis for improved noise margin.

The FCT162646T has balanced output drive with current limiting resistors. This offers low ground bounce, minimal undershoot, and controlled output fall times—reducing the need for external series terminating resistors. The FCT162646T is a plug-in replacement for the FCT16646T and ABT16646 for on-board bus interface applications.

FUNCTIONAL BLOCK DIAGRAM

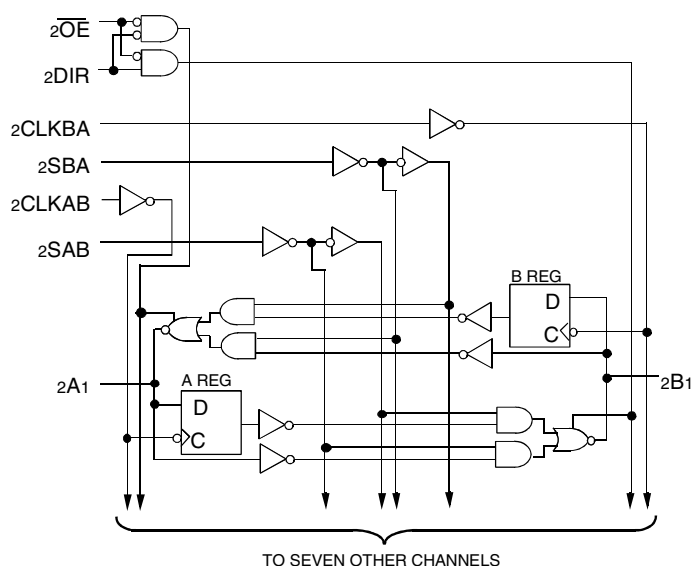
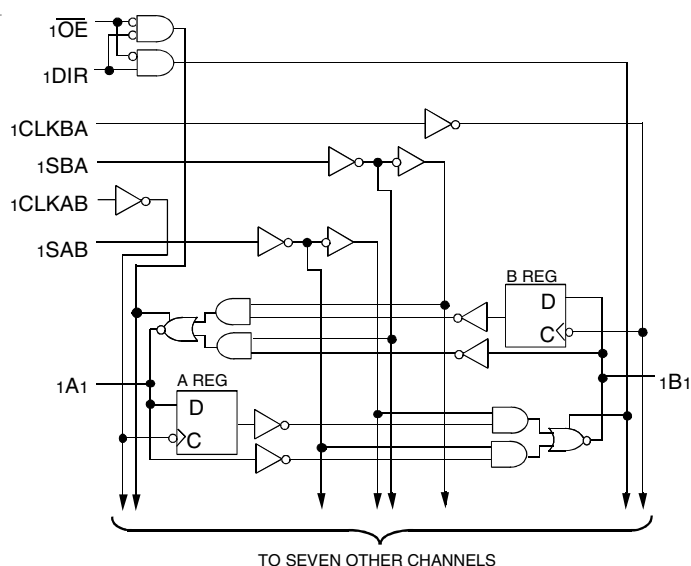

The IDT logo is a registered trademark of Integrated Device Technology, Inc.

INDUSTRIAL TEMPERATURE RANGE

APRIL 2002

PIN CONFIGURATION

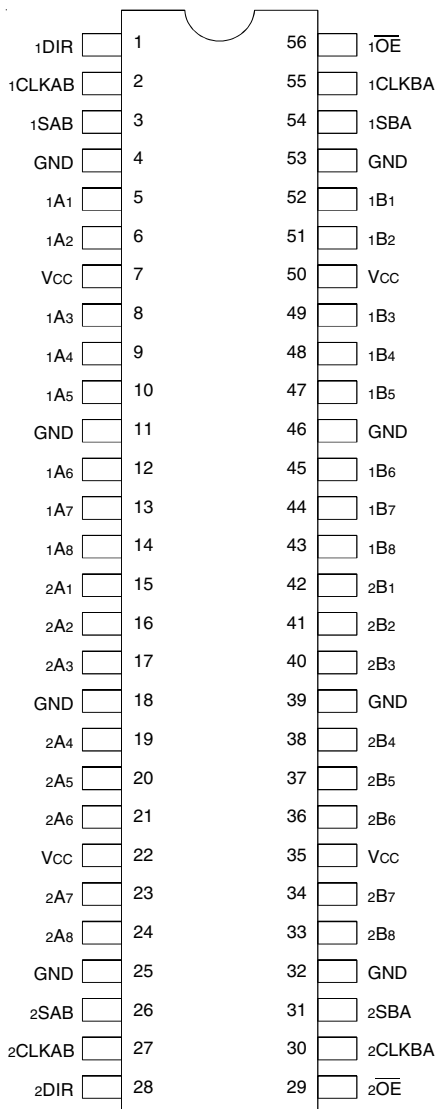

SSOP/ TSSOP/ TVSOP
TOP VIEW

ABSOLUTE MAXIMUM RATINGS⁽¹⁾

Symbol	Description	Max	Unit
VTERM ⁽²⁾	Terminal Voltage with Respect to GND	-0.5 to 7	V
VTERM ⁽³⁾	Terminal Voltage with Respect to GND	-0.5 to VCC+0.5	V
TSTG	Storage Temperature	-65 to +150	°C
IOUT	DC Output Current	-60 to +120	mA

NOTES:

- Stresses greater than those listed under ABSOLUTE MAXIMUM RATINGS may cause permanent damage to the device. This is a stress rating only and functional operation of the device at these or any other conditions above those indicated in the operational sections of this specification is not implied. Exposure to absolute maximum rating conditions for extended periods may affect reliability.
- All device terminals except FCT162XXX Output and I/O terminals.
- Output and I/O terminals for FCT162XXX.

CAPACITANCE (TA = +25°C, F = 1.0MHz)

Symbol	Parameter ⁽¹⁾	Conditions	Typ.	Max.	Unit
CIN	Input Capacitance	VIN = 0V	3.5	6	pF
C _{I/O}	I/O Capacitance	VOUT = 0V	3.5	8	pF

NOTE:

- This parameter is measured at characterization but not tested.

PIN DESCRIPTION

Pin Names	Description
xAx	Data Register A Inputs Data Register B Outputs
xBx	Data Register B Inputs Data Register A Outputs
xCLKAB, xCLKBA	Clock Pulse Inputs
xSAB, xSBA	Output Data Source Select Inputs
xDIR, xOE	Output Enable Inputs

FUNCTION TABLE⁽²⁾

Inputs						Data I/O ⁽¹⁾		Operation or Function
xOE	xDIR	xCLKAB	xCLKBA	xSAB	xSBA	xAx	xBx	
H	X	H or L	H or L	X	X	Input	Input	Isolation
H	X	↑	↑	X	X			Store A and B Data
L	L	X	X	X	L	Output	Input	Real Time B Data to A Bus
L	L	X	H or L	X	H			Stored B Data to A Bus
L	H	X	X	L	X	Input	Output	Real Time A Data to B Bus
L	H	H or L	X	H	X			Stored A Data to B Bus

NOTES:

- The data output functions may be enabled or disabled by various signals at the xOE or xDIR inputs. Data input functions are always enabled, i.e., data at the bus pins will be stored on every LOW-to-HIGH transition on the clock inputs.
- H = HIGH Voltage Level
L = LOW Voltage Level
X = Don't Care
↑ = LOW-to-HIGH Transition

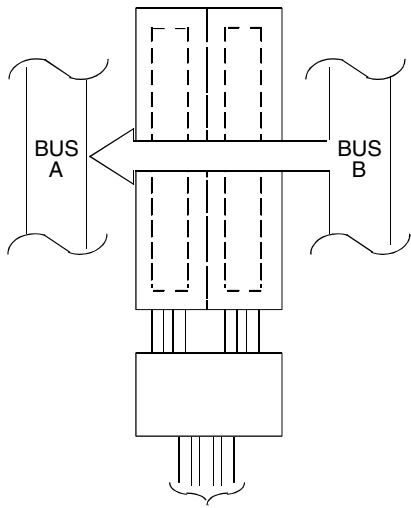

xDIR	x $\overline{\text{OE}}$	xCLKAB	xCLKBA	xSAB	xSBA
L	L	X	X	X	L

Real-Time Transfer Bus B to A

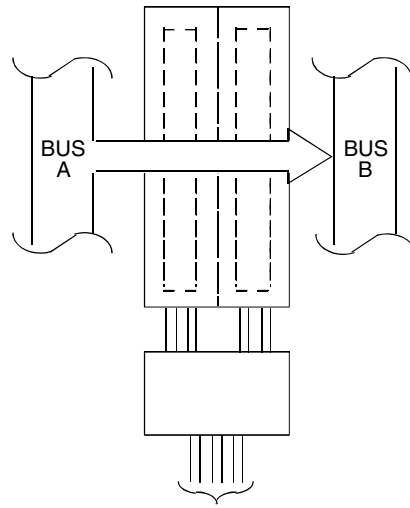

xDIR	x $\overline{\text{OE}}$	xCLKAB	xCLKBA	xSAB	xSBA
H	L	X	X	L	X

Real-Time Transfer Bus A to B

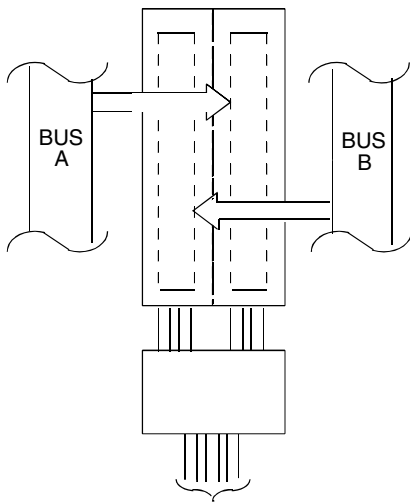

xDIR	x $\overline{\text{OE}}$	xCLKAB	xCLKBA	xSAB	xSBA
H	L	↑	X	X	X
L	L	X	↑	X	X
X	H	↑	↑	X	X

Storage From A and/or B

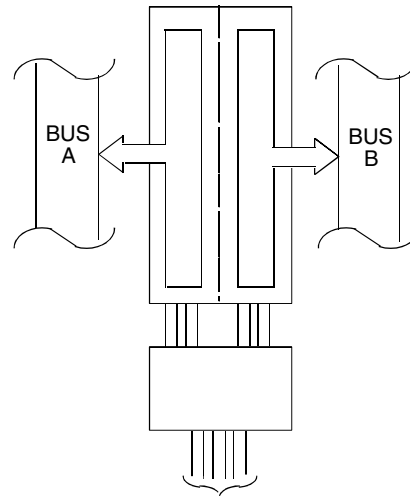

xDIR ⁽¹⁾	x $\overline{\text{OE}}$	xCLKAB	xCLKBA	xSAB	xSBA
L	L	X	H or L	X	H
H	L	H or L	X	H	X

Transfer Stored Data to A and/or B

NOTE:

1. Cannot transfer data to A bus and B bus simultaneously.

DC ELECTRICAL CHARACTERISTICS OVER OPERATING RANGE

Following Conditions Apply Unless Otherwise Specified:

Industrial: $T_A = -40^{\circ}\text{C}$ to $+85^{\circ}\text{C}$, $V_{CC} = 5.0\text{V} \pm 10\%$

Symbol	Parameter	Test Conditions ⁽¹⁾		Min.	Typ. ⁽²⁾	Max.	Unit
V_{IH}	Input HIGH Level	Guaranteed Logic HIGH Level		2	—	—	V
V_{IL}	Input LOW Level	Guaranteed Logic LOW Level		—	—	0.8	V
I_{IH}	Input HIGH Current (Input pins) ⁽⁴⁾	$V_{CC} = \text{Max.}$	$V_I = V_{CC}$	—	—	± 1	μA
	Input HIGH Current (I/O pins) ⁽⁴⁾			—	—	± 1	
I_{IL}	Input LOW Current (Input pins) ⁽⁴⁾		$V_I = \text{GND}$	—	—	± 1	
	Input LOW Current (I/O pins) ⁽⁴⁾			—	—	± 1	
I_{OZH}	High Impedance Output Current (3-State Output pins) ⁽⁴⁾	$V_{CC} = \text{Max.}$	$V_O = 2.7\text{V}$	—	—	± 1	μA
I_{OZL}			$V_O = 0.5\text{V}$	—	—	± 1	
V_{IK}	Clamp Diode Voltage	$V_{CC} = \text{Min.}, I_{IN} = -18\text{mA}$		—	-0.7	-1.2	V
I_{OS}	Short Circuit Current	$V_{CC} = \text{Max.}, V_O = \text{GND}^{(3)}$		-80	-140	-250	mA
V_H	Input Hysteresis	—		—	100	—	mV
I_{CCL} I_{CCH} I_{CCZ}	Quiescent Power Supply Current	$V_{CC} = \text{Max.}$ $V_{IN} = \text{GND or } V_{CC}$		—	5	500	μA

OUTPUT DRIVE CHARACTERISTICS

Symbol	Parameter	Test Conditions ⁽¹⁾		Min.	Typ. ⁽²⁾	Max.	Unit
I_{ODL}	Output LOW Current	$V_{CC} = 5\text{V}, V_{IN} = V_{IH} \text{ or } V_{IL}, V_O = 1.5\text{V}^{(3)}$		60	115	200	mA
I_{ODH}	Output HIGH Current	$V_{CC} = 5\text{V}, V_{IN} = V_{IH} \text{ or } V_{IL}, V_O = 1.5\text{V}^{(3)}$		-60	-115	-200	mA
V_{OH}	Output HIGH Voltage	$V_{CC} = \text{Min.}$ $V_{IN} = V_{IH} \text{ or } V_{IL}$	$I_{OH} = -24\text{mA}$	2.4	3.3	—	V
V_{OL}	Output LOW Voltage	$V_{CC} = \text{Min.}$ $V_{IN} = V_{IH} \text{ or } V_{IL}$	$I_{OL} = 24\text{mA}$	—	0.3	0.55	V

NOTES:

1. For conditions shown as Min. or Max., use appropriate value specified under Electrical Characteristics for the applicable device type.

2. Typical values are at $V_{CC} = 5.0\text{V}$, $+25^{\circ}\text{C}$ ambient.

3. Not more than one output should be shorted at one time. Duration of the test should not exceed one second.

4. The test limit for this parameter is $\pm 5\mu\text{A}$ at $T_A = -55^{\circ}\text{C}$.

POWER SUPPLY CHARACTERISTICS

Symbol	Parameter	Test Conditions ⁽¹⁾		Min.	Typ. ⁽²⁾	Max.	Unit
ΔI_{CC}	Quiescent Power Supply Current TTL Inputs HIGH	V _{CC} = Max. V _{IN} = 3.4V ⁽³⁾		—	0.5	1.5	mA
I _{CCD}	Dynamic Power Supply Current ⁽⁴⁾	V _{CC} = Max. Outputs Open xDIR = x \overline{OE} = GND One Input Toggling 50% Duty Cycle	V _{IN} = V _{CC} V _{IN} = GND	—	75	120	μ A/ MHz
I _C	Total Power Supply Current ⁽⁶⁾	V _{CC} = Max. Outputs Open f _{CP} = 10MHz (xCLKBA) 50% Duty Cycle xDIR = x \overline{OE} = GND One Bit Toggling f _i = 5MHz 50% Duty Cycle	V _{IN} = V _{CC} V _{IN} = GND	—	0.8	1.7	mA
			V _{IN} = 3.4V V _{IN} = GND	—	1.3	3.2	
		V _{CC} = Max. Outputs Open f _{CP} = 10MHz (xCLKBA) 50% Duty Cycle xDIR = x \overline{OE} = GND Sixteen Bits Toggling f _i = 2.5MHz 50% Duty Cycle	V _{IN} = V _{CC} V _{IN} = GND	—	3.8	6.5 ⁽⁵⁾	
			V _{IN} = 3.4V V _{IN} = GND	—	8.3	20 ⁽⁵⁾	

NOTES:

- For conditions shown as Min. or Max., use appropriate value specified under Electrical Characteristics for the applicable device type.
- Typical values are at V_{CC} = 5.0V, +25°C ambient.
- Per TTL driven input (V_{IN} = 3.4V). All other inputs at V_{CC} or GND.
- This parameter is not directly testable, but is derived for use in Total Power Supply Calculations.
- Values for these conditions are examples of the I_{CC} formula. These limits are guaranteed but not tested.
- I_C = I_{QUIESCENT} + I_{INPUTS} + I_{DYNAMIC}
 $I_C = I_{CC} + \Delta I_{CC} \cdot DH_{NT} + I_{CCD} (f_{CP}N_{CP}/2 + f_i N_i)$
 I_{CC} = Quiescent Current (I_{CC1}, I_{CC2} and I_{CC3})
 ΔI_{CC} = Power Supply Current for a TTL High Input (V_{IN} = 3.4V)
 DH = Duty Cycle for TTL Inputs High
 NT = Number of TTL Inputs at DH
 I_{CCD} = Dynamic Current caused by an Input Transition Pair (HLH or LHL)
 f_{CP} = Clock Frequency for Register Devices (Zero for Non-Register Devices)
 N_{CP} = Number of Clock Inputs at f_{CP}
 f_i = Input Frequency
 N_i = Number of Inputs at f_i

SWITCHING CHARACTERISTICS OVER OPERATING RANGE

Symbol	Parameter	Condition ⁽¹⁾	FCT162646AT		FCT162646CT		Unit
			Min. ⁽²⁾	Max.	Min. ⁽²⁾	Max.	
t _{PLH} t _{PHL}	Propagation Delay Bus to Bus	C _L = 50pF R _L = 500Ω	2	6.3	1.5	4.3	ns
t _{PZH} t _{PZL}	Output Enable Time xDIR or xOE to Bus		2	9.8	1.5	4.8	ns
t _{PHZ} t _{PLZ}	Output Disable Time xDIR or xOE to Bus		2	6.3	1.5	4.3	ns
t _{PLH} t _{PHL}	Propagation Delay Clock to Bus		2	6.3	1.5	3.8	ns
t _{PLH} t _{PHL}	Propagation Delay xSBA or xSAB to Bus		2	7.7	1.5	4.2	ns
t _{SU}	Set-up Time HIGH or LOW Bus to Clock		2	—	2	—	ns
t _H	Hold Time HIGH or LOW Bus to Clock		1.5	—	0	—	ns
t _W	Clock Pulse Width HIGH or LOW		5	—	3	—	ns
t _{SK(o)}	Output Skew ⁽³⁾		—	0.5	—	0.5	ns

NOTES:

1. See test circuits and waveforms.
2. Minimum limits are guaranteed but not tested on Propagation Delays.
3. Skew between any two outputs of the same package switching in the same direction. This parameter is guaranteed by design.

TEST CIRCUITS AND WAVEFORMS

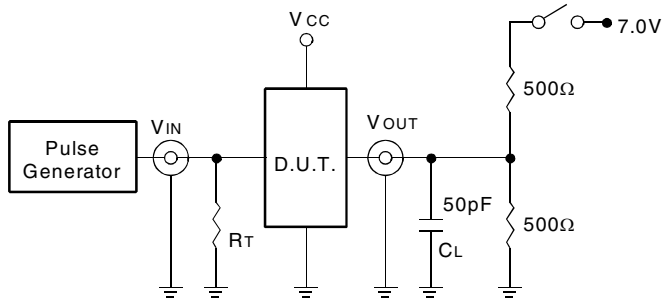

Test Circuits for All Outputs

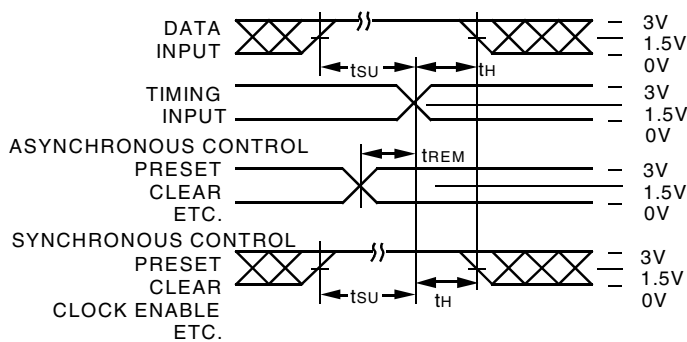

Set-up, Hold, and Release Times

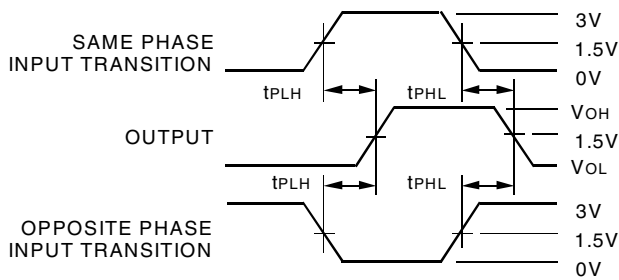

Propagation Delay

SWITCH POSITION

Test	Switch
Open Drain Disable Low Enable Low	Closed
All Other Tests	Open

DEFINITIONS:

CL = Load capacitance: includes jig and probe capacitance.

RT = Termination resistance: should be equal to ZOUT of the Pulse Generator.

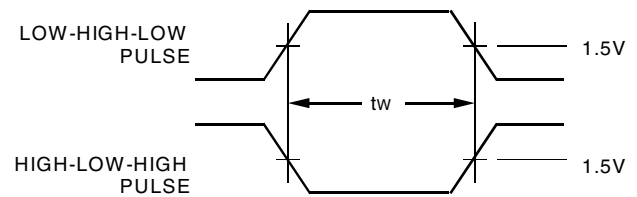

Pulse Width

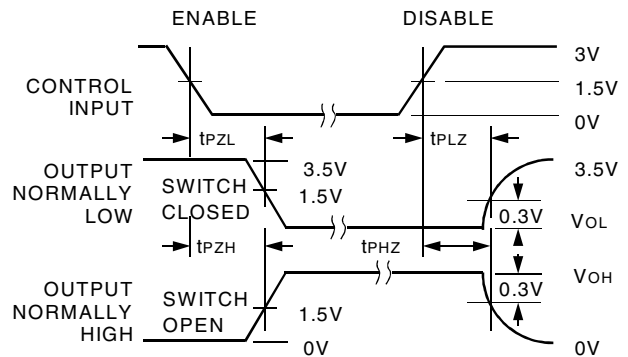

Enable and Disable Times

NOTES:

1. Diagram shown for input Control Enable-LOW and input Control Disable-HIGH.
2. Pulse Generator for All Pulses: Rate $\leq 1.0\text{MHz}$; $t_r \leq 2.5\text{ns}$; $t_f \leq 2.5\text{ns}$.

ORDERING INFORMATION

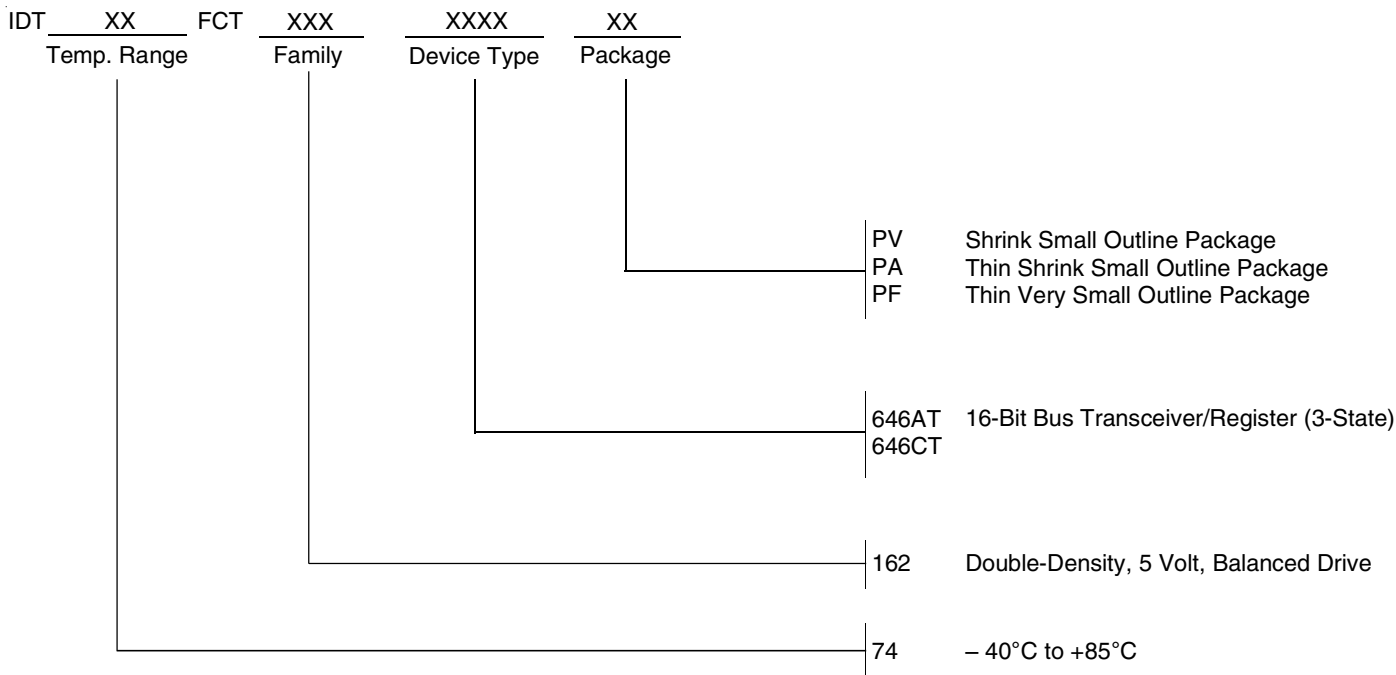

DATA SHEET DOCUMENT HISTORY

- 1/21/2002 Removed Military temp grade
- 3/28/2002 Removed standard speed grade



CORPORATE HEADQUARTERS
 2975 Stender Way
 Santa Clara, CA 95054

for SALES:
 800-345-7015 or 408-727-6116
 fax: 408-492-8674
 www.idt.com

for Tech Support:
 logichelp@idt.com
 (408) 654-6459



LittleDiode supplies new, hard to find or obsolete electronic components and semiconductors all over the world.

With over two million different components listed you are sure to find the part you need.

Feel free to visit us today at our online store:

LittleDiode.com

Looking forward to providing you with the best possible service.