



FAST CMOS 16-BIT LATCHED TRANSCEIVER

IDT74FCT16543AT/CT/ET

FEATURES:

- 0.5 MICRON CMOS Technology
- High-speed, low-power CMOS replacement for ABT functions
- Typical $t_{sk(o)}$ (Output Skew) < 250ps
- Low input and output leakage $\leq 1\mu A$ (max.)
- $V_{CC} = 5V \pm 10\%$
- High drive outputs (-32mA IOH, 64mA IOL)
- Power off disable outputs permit "live insertion"
- Typical V_{OLP} (Output Ground Bounce) < 1.0V at $V_{CC} = 5V$, $T_A = 25^\circ C$
- Available in SSOP, TSSOP, and TVSOP packages

DESCRIPTION:

The FCT16543T 16-bit latched transceivers are built using advanced dual metal CMOS technology. These high-speed, low-power devices are organized as two independent 8-bit D-type latched transceivers with separate input and output control to permit independent control of data flow in either direction. For example, the A-to-B Enable (\overline{xCEAB}) must be low in order to enter data from the A port or to output data from the B port. \overline{xLEAB} controls the latch function. When \overline{xLEAB} is low, the latches are transparent. A subsequent low-to-high transition of \overline{xLEAB} signal puts the A latches in the storage mode. \overline{xOEAB} performs output enable function on the B port. Data flow from the B port to the A port is similar but requires using \overline{xCEBA} , \overline{xLEBA} , and \overline{xOEBA} inputs. Flow-through organization of signal pins simplifies layout. All inputs are designed with hysteresis for improved noise margin.

The FCT16543T is ideally suited for driving high-capacitance loads and low-impedance backplanes. The output buffers are designed with power off disable capability to allow "live insertion" of boards when used as backplane drivers.

FUNCTIONAL BLOCK DIAGRAM

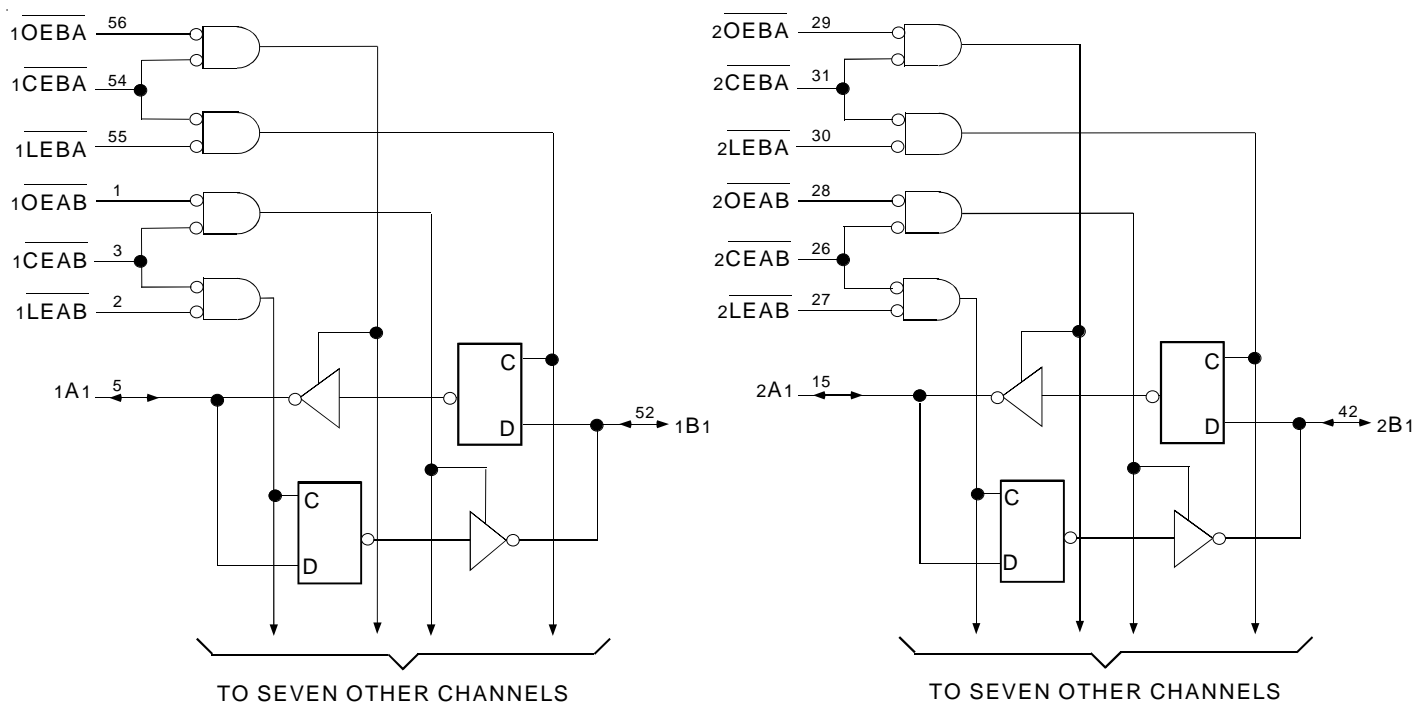

The IDT logo is a registered trademark of Integrated Device Technology, Inc.

INDUSTRIAL TEMPERATURE RANGE

JULY 2002

PIN CONFIGURATION

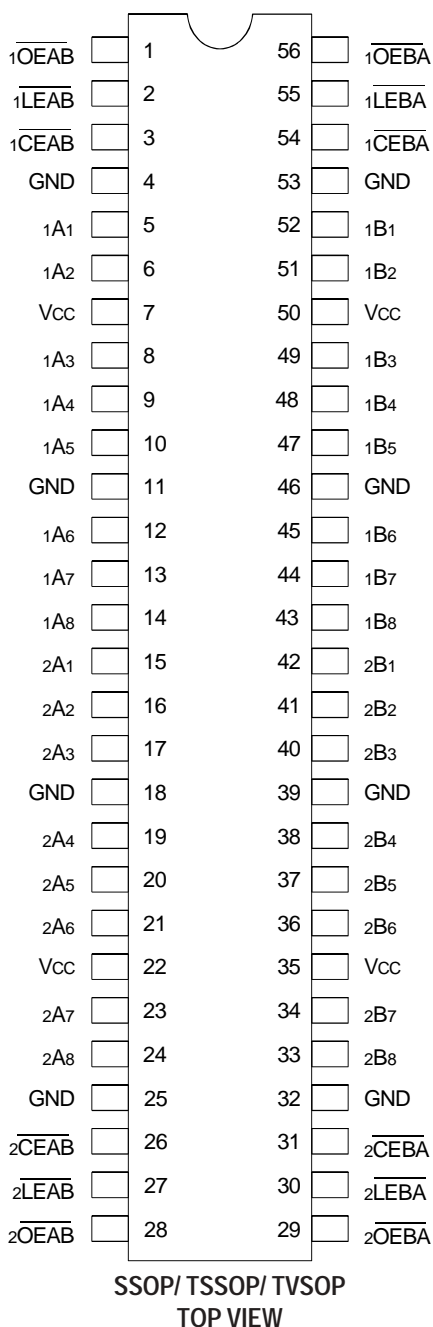

PIN DESCRIPTION

Pin Names	Description
xOEAB	A-to-B Output Enable Input (Active LOW)
xOEBĀ	B-to-A Output Enable Input (Active LOW)
xCEAB	A-to-B Enable Input (Active LOW)
xCEBĀ	B-to-A Enable Input (Active LOW)
xLEAB	A-to-B Latch Enable Input (Active LOW)
xLEBĀ	B-to-A Latch Enable Input (Active LOW)
xAx	A-to-B Data Inputs or B-to-A 3-State Outputs
xBx	B-to-A Data Inputs or A-to-B 3-State Outputs

ABSOLUTE MAXIMUM RATINGS⁽¹⁾

Symbol	Description	Max	Unit
VTERM ⁽²⁾	Terminal Voltage with Respect to GND	-0.5 to 7	V
VTERM ⁽³⁾	Terminal Voltage with Respect to GND	-0.5 to Vcc+0.5	V
TSTG	Storage Temperature	-65 to +150	°C
IOUT	DC Output Current	-60 to +120	mA

NOTES:

- Stresses greater than those listed under ABSOLUTE MAXIMUM RATINGS may cause permanent damage to the device. This is a stress rating only and functional operation of the device at these or any other conditions above those indicated in the operational sections of this specification is not implied. Exposure to absolute maximum rating conditions for extended periods may affect reliability.
- All device terminals except FCT162XXX Output and I/O terminals.
- Outputs and I/O terminals for FCT162XXX.

CAPACITANCE (TA = +25°C, f = 1.0MHz)

Symbol	Parameter ⁽¹⁾	Conditions	Typ.	Max.	Unit
CIN	Input Capacitance	VIN = 0V	3.5	6	pF
COUT	Output Capacitance	VOUT = 0V	3.5	8	pF

NOTE:

- This parameter is measured at characterization but not tested.

FUNCTION TABLE^(1, 2)

For A-to-B (Symmetric with B-to-A)

Inputs			Latch Status	Output Buffers
xCEAB	xLEAB	xOEAB	xAx to xBx	xBx
H	X	X	Storing	Z
X	H	X	Storing	X
L	L	L	Transparent	Current A Inputs
L	H	L	Storing	Previous* A Inputs
L	L	H	Transparent	Z
L	H	H	Storing	Z

NOTES:

- * Before xLEAB LOW-to-HIGH Transition
H = HIGH Voltage Level
L = LOW Voltage Level
X = Don't Care
- A-to-B data flow shown; B-to-A flow control is the same, except using xCEBĀ, xLEBĀ and xOEBĀ.

DC ELECTRICAL CHARACTERISTICS OVER OPERATING RANGE

Following Conditions Apply Unless Otherwise Specified:

Industrial: $T_A = -40^{\circ}\text{C}$ to $+85^{\circ}\text{C}$, $V_{CC} = 5.0\text{V} \pm 10\%$

Symbol	Parameter	Test Conditions ⁽¹⁾		Min.	Typ. ⁽²⁾	Max.	Unit
V_{IH}	Input HIGH Level	Guaranteed Logic HIGH Level		2	—	—	V
V_{IL}	Input LOW Level	Guaranteed Logic LOW Level		—	—	0.8	V
I_{IH}	Input HIGH Current (Input pins) ⁽⁵⁾	$V_{CC} = \text{Max.}$	$V_i = V_{CC}$	—	—	± 1	μA
	Input HIGH Current (I/O pins) ⁽⁵⁾			—	—	± 1	
I_{IL}	Input LOW Current (Input pins) ⁽⁵⁾		$V_i = \text{GND}$	—	—	± 1	
	Input LOW Current (I/O pins) ⁽⁵⁾			—	—	± 1	
I_{OZH}	High Impedance Output Current (3-State Output pins) ⁽⁵⁾	$V_{CC} = \text{Max.}$	$V_o = 2.7\text{V}$	—	—	± 1	μA
I_{OZL}			$V_o = 0.5\text{V}$	—	—	± 1	
V_{IK}	Clamp Diode Voltage	$V_{CC} = \text{Min.}, I_{IN} = -18\text{mA}$		—	-0.7	-1.2	V
I_{OS}	Short Circuit Current	$V_{CC} = \text{Max.}, V_o = \text{GND}^{(3)}$		-80	-140	-250	mA
V_H	Input Hysteresis	—		—	100	—	mV
I_{CCL}	Quiescent Power Supply Current	$V_{CC} = \text{Max}$		—	5	500	μA
I_{CCH}		$V_{IN} = \text{GND or } V_{CC}$					
I_{CCZ}							

OUTPUT DRIVE CHARACTERISTICS

Symbol	Parameter	Test Conditions ⁽¹⁾		Min.	Typ. ⁽²⁾	Max.	Unit
I_o	Output Drive Current	$V_{CC} = \text{Max.}, V_o = 2.5\text{V}^{(3)}$		-50	—	-180	mA
V_{OH}	Output HIGH Voltage	$V_{CC} = \text{Min.}$ $V_{IN} = V_{IH} \text{ or } V_{IL}$	$I_{OH} = -3\text{mA}$	2.5	3.5	—	V
			$I_{OH} = -15\text{mA}$	2.4	3.5	—	V
			$I_{OH} = -32\text{mA}^{(4)}$	2	3	—	V
V_{OL}	Output LOW Voltage	$V_{CC} = \text{Min.}$ $V_{IN} = V_{IH} \text{ or } V_{IL}$	$I_{OL} = 64\text{mA}$	—	0.2	0.55	V
I_{OFF}	Input/Output Power Off Leakage ⁽⁵⁾	$V_{CC} = 0\text{V}, V_{IN} = \text{ or } V_o \leq 4.5\text{V}$		—	—	± 1	μA

NOTES:

1. For conditions shown as Min. or Max., use appropriate value specified under Electrical Characteristics for the applicable device type.
2. Typical values are at $V_{CC} = 5.0\text{V}$, $+25^{\circ}\text{C}$ ambient.
3. Not more than one output should be shorted at one time. Duration of the test should not exceed one second.
4. Duration of the condition can not exceed one second.
5. This test limit for this parameter is $\pm 5\mu\text{A}$ at $T_A = -55^{\circ}\text{C}$.

POWER SUPPLY CHARACTERISTICS

Symbol	Parameter	Test Conditions ⁽¹⁾		Min.	Typ. ⁽²⁾	Max.	Unit
ΔI_{CC}	Quiescent Power Supply Current TTL Inputs HIGH	$V_{CC} = \text{Max.}$ $V_{IN} = 3.4V^{(3)}$		—	0.5	1.5	mA
I_{CCD}	Dynamic Power Supply Current ⁽⁴⁾	$V_{CC} = \text{Max.}$, Outputs Open \overline{xCEAB} and $\overline{xOEAB} = \text{GND}$ $\overline{xCEBA} = V_{CC}$ One Input Toggling 50% Duty Cycle	$V_{IN} = V_{CC}$ $V_{IN} = \text{GND}$	—	60	100	$\mu A / \text{MHz}$
I_C	Total Power Supply Current ⁽⁶⁾	$V_{CC} = \text{Max.}$, Outputs Open $f_i = 10\text{MHz}$ 50% Duty Cycle \overline{xLEAB} , \overline{xCEAB} and $\overline{xOEAB} = \text{GND}$ $\overline{xCEBA} = V_{CC}$ One Bit Toggling	$V_{IN} = V_{CC}$ $V_{IN} = \text{GND}$	—	0.6	1.5	mA
			$V_{IN} = 3.4V$ $V_{IN} = \text{GND}$	—	0.9	2.3	
		$V_{CC} = \text{Max.}$, Outputs Open $f_i = 2.5\text{MHz}$ 50% Duty Cycle \overline{xLEAB} , \overline{xCEAB} and $\overline{xOEAB} = \text{GND}$ $\overline{xCEBA} = V_{CC}$ Sixteen Bits Toggling	$V_{IN} = V_{CC}$ $V_{IN} = \text{GND}$	—	2.4	4.5 ⁽⁵⁾	
			$V_{IN} = 3.4V$ $V_{IN} = \text{GND}$	—	6.4	16.5 ⁽⁵⁾	

NOTES:

- For conditions shown as Max. or Min., use appropriate value specified under Electrical Characteristics for the applicable device type.
- Typical values are at $V_{CC} = 5.0V$, $+25^\circ\text{C}$ ambient.
- Per TTL driven input ($V_{IN} = 3.4V$). All other inputs at V_{CC} or GND.
- This parameter is not directly testable, but is derived for use in Total Power Supply Calculations.
- Values for these conditions are examples of the I_{CC} formula. These limits are guaranteed but not tested.
- $I_C = I_{QUIESCENT} + I_{INPUTS} + I_{DYNAMIC}$
 $I_C = I_{CC} + \Delta I_{CC} D_H N_T + I_{CCD} (f_{CP} N_{CP} / 2 + f_i N_i)$
 $I_{CC} = \text{Quiescent Current (} I_{CCL}, I_{CCH} \text{ and } I_{CCZ})$
 $\Delta I_{CC} = \text{Power Supply Current for a TTL High Input (} V_{IN} = 3.4V)$
 $D_H = \text{Duty Cycle for TTL Inputs High}$
 $N_T = \text{Number of TTL Inputs at } D_H$
 $I_{CCD} = \text{Dynamic Current Caused by an Input Transition Pair (HLH or LHL)}$
 $f_{CP} = \text{Clock Frequency for Register Devices (Zero for Non-Register Devices)}$
 $N_{CP} = \text{Number of Clock Inputs at } f_{CP}$
 $f_i = \text{Input Frequency}$
 $N_i = \text{Number of Inputs at } f_i$

SWITCHING CHARACTERISTICS OVER OPERATING RANGE

Symbol	Parameter	Condition ⁽²⁾	74FCT16543AT		74FCT16543CT		74FCT16543ET		Unit
			Min. ⁽²⁾	Max.	Min. ⁽²⁾	Max.	Min. ⁽²⁾	Max.	
t _{PLH} t _{PHL}	Propagation Delay Transparent Mode xAx to xBx or xBx to xAx	C _L = 50pF R _L = 500Ω	1.5	6.5	1.5	5.1	1.5	3.4	ns
t _{PLH} t _{PHL}	Propagation Delay xLEBA to xAx, xLEAB to xBx		1.5	8	1.5	5.6	1.5	3.7	ns
t _{PHZ} t _{PLZ}	Output Enable Time xOEBA or xOEAB to xAx or xBx xCEBA or xCEAB to xAx or xBx		1.5	9	1.5	7.8	1.5	4.8	ns
t _{PZH} t _{PZL}	Output Disable Time xOEBA or xOEAB to xAx or xBx xCEBA or xCEAB to xAx or xBx		1.5	7.5	1.5	6.5	1.5	4	ns
t _{SU}	Set-up Time HIGH or LOW xAx or xBx to xLEAB or xLEBA		2	—	2	—	1	—	ns
t _H	Hold Time HIGH or LOW xAx or xBx to xLEAB or xLEBA		2	—	2	—	1	—	ns
t _w	xLEAB or xLEBA Pulse Width LOW		4	—	4	—	3 ⁽⁴⁾	—	ns
t _{SK(o)}	Output Skew ⁽³⁾		—	0.5	—	0.5	—	0.5	ns

NOTES:

1. See test circuit and waveforms.
2. Minimum limits are guaranteed but not tested on Propagation Delays.
3. Skew between any two outputs, of the same package, switching in the same direction. This parameter is guaranteed by design.
4. This limit is guaranteed but not tested.

TEST CIRCUITS AND WAVEFORMS

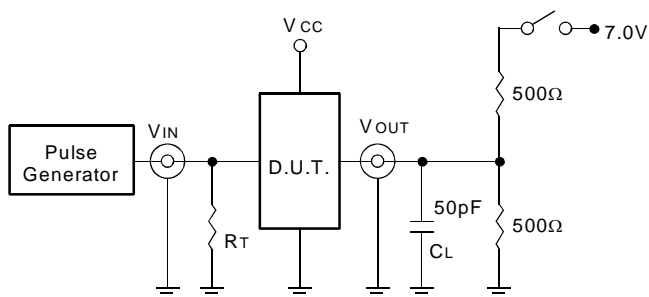

Test Circuits for All Outputs

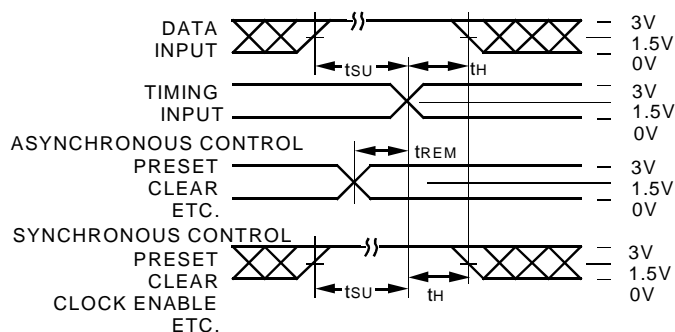

Set-up, Hold, and Release Times

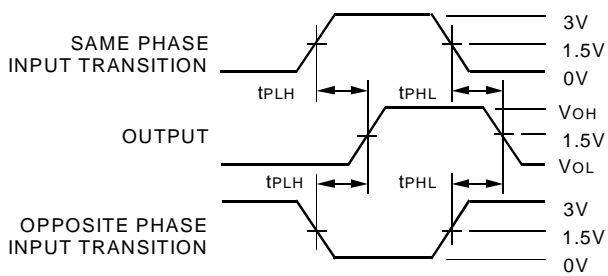

Propagation Delay

SWITCH POSITION

Test	Switch
Open Drain Disable Low Enable Low	Closed
All Other Tests	Open

DEFINITIONS:

CL = Load capacitance: includes jig and probe capacitance.
RT = Termination resistance: should be equal to ZOUT of the Pulse Generator.

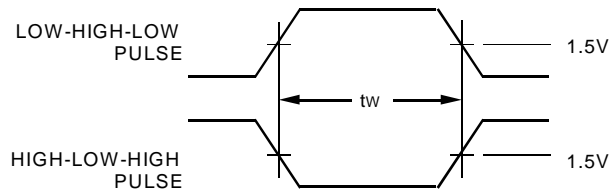

Pulse Width

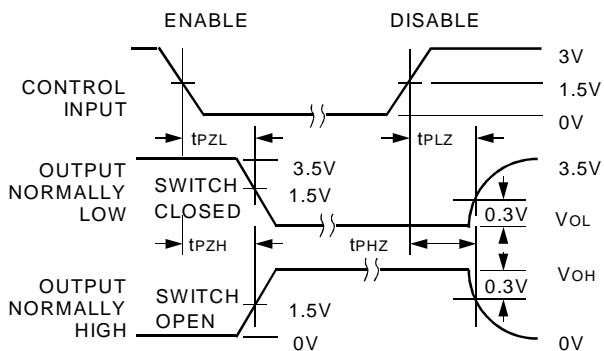

Enable and Disable Times

NOTES:

1. Diagram shown for input Control Enable-LOW and input Control Disable-HIGH.
2. Pulse Generator for All Pulses: Rate $\leq 1.0\text{MHz}$; $t_r \leq 2.5\text{ns}$; $t_r \leq 2.5\text{ns}$.

ORDERING INFORMATION

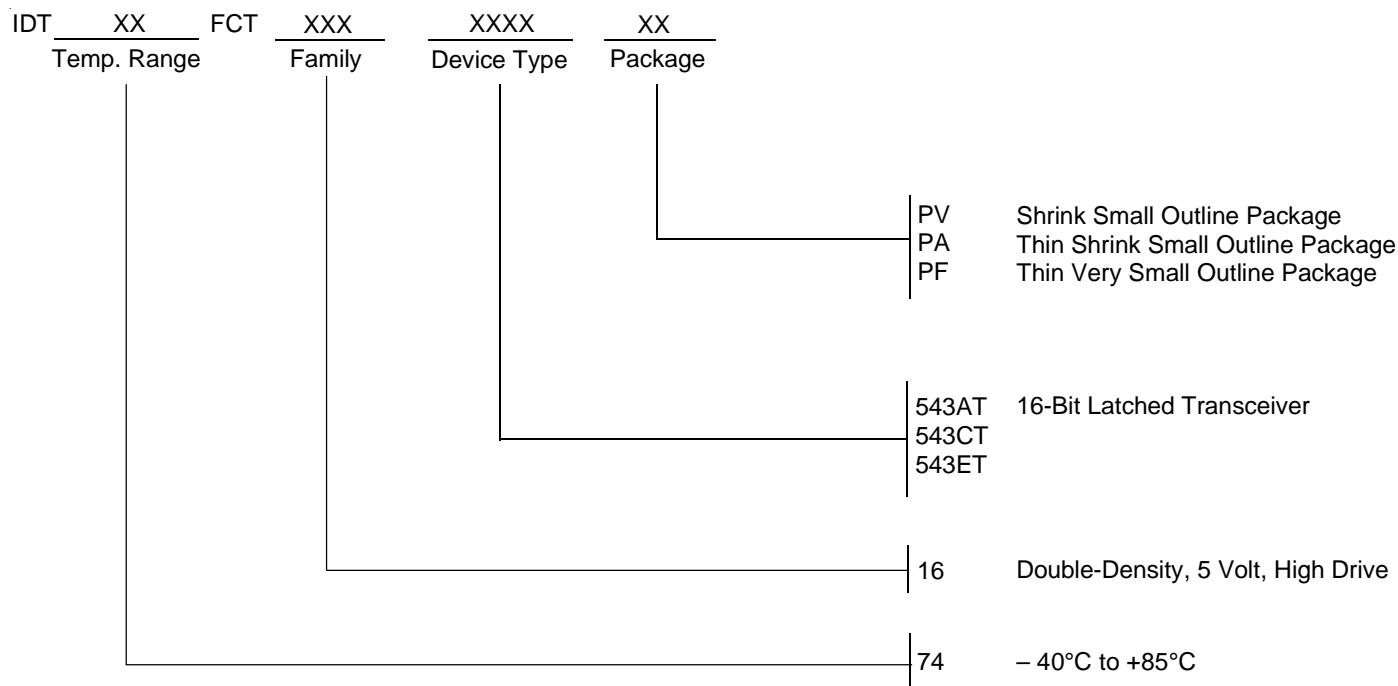

DATA SHEET DOCUMENT HISTORY

6/21/2002 Updated according to PDNs Logic-00-07 and Logic-01-04



CORPORATE HEADQUARTERS
2975 Stender Way
Santa Clara, CA 95054

for SALES:
800-345-7015 or 408-727-6116
fax: 408-492-8674
www.idt.com

for Tech Support:
logichelp@idt.com
(408) 654-6459



LittleDiode supplies new, hard to find or obsolete electronic components and semiconductors all over the world.

With over two million different components listed you are sure to find the part you need.

Feel free to visit us today at our online store:

LittleDiode.com

Looking forward to providing you with the best possible service.