



### 3.3V CMOS OCTAL TRANSPARENT D-TYPE LATCH WITH 3-STATE OUTPUTS AND 5 VOLT TOLERANT I/O

IDT74LVC573A

#### FEATURES:

- 0.5 MICRON CMOS Technology
- ESD > 2000V per MIL-STD-883, Method 3015; > 200V using machine model (C = 200pF, R = 0)
- Vcc = 3.3V ± 0.3V, Normal Range
- Vcc = 2.7V to 3.6V, Extended Range
- CMOS power levels (0.4µW typ. static)
- Rail-to-rail output swing for increased noise margin
- All inputs, outputs, and I/O are 5V tolerant
- Supports hot insertion
- Available in SOIC, SSOP, QSOP, and TSSOP packages

#### DRIVE FEATURES:

- High Output Drivers: ±24mA
- Reduced system switching noise

#### APPLICATIONS:

- 5V and 3.3V mixed voltage systems
- Data communication and telecommunication systems

#### DESCRIPTION:

The LVC573A octal transparent D-type latch is built using advanced dual metal CMOS technology. The device features 3-state outputs designed specifically for driving highly capacitive or relatively low-impedance loads, and is particularly suitable for implementing buffer registers, input-output (I/O) ports, bidirectional bus drivers, and working registers.

While the latch-enable (LE) input is high, the Q outputs follow the data (D) inputs. When LE is taken low, the Q outputs are latched at the logic levels at the D inputs.

A buffered output-enable ( $\overline{OE}$ ) input can be used to place the eight outputs in either a normal logic state (high or low logic levels) or a high-impedance state. In the high-impedance state, the outputs neither load nor drive the bus lines significantly. The high-impedance state and increased drive provide the capability to drive bus lines without interface or pullup components.  $\overline{OE}$  does not affect the internal operations of the latch. Old data can be retained or new data can be entered while the outputs are in the high-impedance state.

The LVC573A has been designed with a ±24mA output driver. This driver is capable of driving a moderate to heavy load while maintaining speed performance.

Inputs can be driven from either 3.3V or 5V devices. This feature allows the use of this device as a translator in a mixed 3.3V/5V system environment.

#### FUNCTIONAL BLOCK DIAGRAM

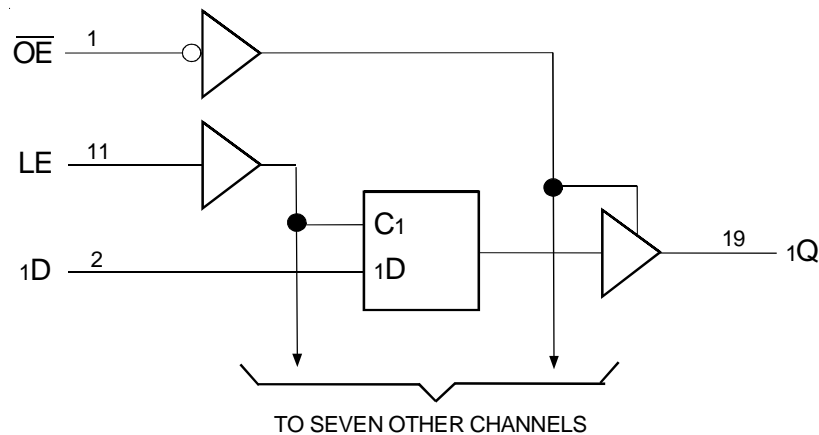

## PIN CONFIGURATION

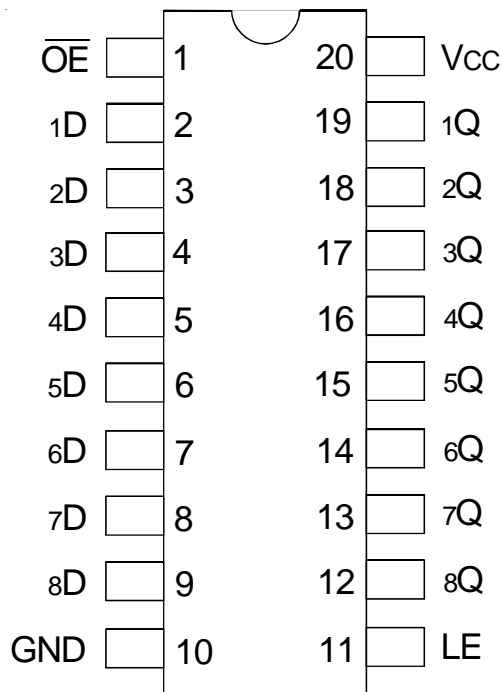

SOIC/ SSOP/ QSOP/ TSSOP  
TOP VIEW

## ABSOLUTE MAXIMUM RATINGS<sup>(1)</sup>

Symbol	Description	Max	Unit
VTERM	Terminal Voltage with Respect to GND	-0.5 to +6.5	V
TSTG	Storage Temperature	-65 to +150	°C
I <sub>OUT</sub>	DC Output Current	-50 to +50	mA
I <sub>IK</sub> I <sub>OK</sub>	Continuous Clamp Current, V <sub>I</sub> < 0 or V <sub>O</sub> < 0	-50	mA
I <sub>CC</sub> I <sub>SS</sub>	Continuous Current through each V <sub>CC</sub> or GND	±100	mA

**NOTE:**

1. Stresses greater than those listed under ABSOLUTE MAXIMUM RATINGS may cause permanent damage to the device. This is a stress rating only and functional operation of the device at these or any other conditions above those indicated in the operational sections of this specification is not implied. Exposure to absolute maximum rating conditions for extended periods may affect reliability.

## CAPACITANCE (T<sub>A</sub> = +25°C, F = 1.0MHz)

Symbol	Parameter <sup>(1)</sup>	Conditions	Typ.	Max.	Unit
C <sub>IN</sub>	Input Capacitance	V <sub>IN</sub> = 0V	4.5	6	pF
C <sub>OUT</sub>	Output Capacitance	V <sub>OUT</sub> = 0V	5.5	8	pF
C <sub>I/O</sub>	I/O Port Capacitance	V <sub>IN</sub> = 0V	6.5	8	pF

**NOTE:**

1. As applicable to the device type.

## PIN DESCRIPTION

Pin Names	Description
$\overline{OE}$	Output Enable Inputs (Active LOW)
LE	Latch Enable Input
xD	Data Inputs
xQ	3-State Data Outputs

## FUNCTION TABLE (EACH LATCH)<sup>(1)</sup>

Inputs			Outputs
xD	LE	$\overline{OE}$	xQ
H	H	L	H
L	H	L	L
X	L	L	Q <sup>(2)</sup>
X	X	H	Z

**NOTES:**

1. H = HIGH Voltage Level  
X = Don't Care  
L = LOW Voltage Level  
Z = High-Impedance
2. Output level before the indicated steady-state input conditions were established.

## DC ELECTRICAL CHARACTERISTICS OVER OPERATING RANGE

Following Conditions Apply Unless Otherwise Specified:

Operating Condition:  $T_A = -40^{\circ}\text{C}$  to  $+85^{\circ}\text{C}$

Symbol	Parameter	Test Conditions		Min.	Typ. <sup>(1)</sup>	Max.	Unit
V <sub>IH</sub>	Input HIGH Voltage Level	V <sub>CC</sub> = 2.3V to 2.7V		1.7	—	—	V
		V <sub>CC</sub> = 2.7V to 3.6V		2	—	—	
V <sub>IL</sub>	Input LOW Voltage Level	V <sub>CC</sub> = 2.3V to 2.7V		—	—	0.7	V
		V <sub>CC</sub> = 2.7V to 3.6V		—	—	0.8	
I <sub>IH</sub> I <sub>IL</sub>	Input Leakage Current	V <sub>CC</sub> = 3.6V	V <sub>I</sub> = 0 to 5.5V	—	—	±5	μA
I <sub>OZH</sub> I <sub>OZL</sub>	High Impedance Output Current (3-State Output pins)	V <sub>CC</sub> = 3.6V	V <sub>O</sub> = 0 to 5.5V	—	—	±10	μA
I <sub>OFF</sub>	Input/Output Power Off Leakage	V <sub>CC</sub> = 0V, V <sub>IN</sub> or V <sub>O</sub> ≤ 5.5V		—	—	±50	μA
V <sub>IK</sub>	Clamp Diode Voltage	V <sub>CC</sub> = 2.3V, I <sub>IN</sub> = -18mA		—	-0.7	-1.2	V
V <sub>H</sub>	Input Hysteresis	V <sub>CC</sub> = 3.3V		—	100	—	mV
I <sub>CC1</sub> I <sub>CC2</sub> I <sub>CC3</sub>	Quiescent Power Supply Current	V <sub>CC</sub> = 3.6V	V <sub>IN</sub> = GND or V <sub>CC</sub>	—	—	10	μA
			3.6 ≤ V <sub>IN</sub> ≤ 5.5V <sup>(2)</sup>	—	—	10	
ΔI <sub>CC</sub>	Quiescent Power Supply Current Variation	One input at V <sub>CC</sub> - 0.6V, other inputs at V <sub>CC</sub> or GND		—	—	500	μA

### NOTES:

- Typical values are at V<sub>CC</sub> = 3.3V, +25°C ambient.
- This applies in the disabled state only.

## OUTPUT DRIVE CHARACTERISTICS

Symbol	Parameter	Test Conditions <sup>(1)</sup>		Min.	Max.	Unit
V <sub>OH</sub>	Output HIGH Voltage	V <sub>CC</sub> = 2.3V to 3.6V	I <sub>OH</sub> = -0.1mA	V <sub>CC</sub> - 0.2	—	V
		V <sub>CC</sub> = 2.3V	I <sub>OH</sub> = -6mA	2	—	
		V <sub>CC</sub> = 2.3V	I <sub>OH</sub> = -12mA	1.7	—	
		V <sub>CC</sub> = 2.7V		2.2	—	
		V <sub>CC</sub> = 3V		2.4	—	
		V <sub>CC</sub> = 3V	I <sub>OH</sub> = -24mA	2.2	—	
V <sub>OL</sub>	Output LOW Voltage	V <sub>CC</sub> = 2.3V to 3.6V	I <sub>OL</sub> = 0.1mA	—	0.2	V
		V <sub>CC</sub> = 2.3V	I <sub>OL</sub> = 6mA	—	0.4	
			I <sub>OL</sub> = 12mA	—	0.7	
		V <sub>CC</sub> = 2.7V	I <sub>OL</sub> = 12mA	—	0.4	
		V <sub>CC</sub> = 3V	I <sub>OL</sub> = 24mA	—	0.55	

### NOTE:

- V<sub>IH</sub> and V<sub>IL</sub> must be within the min. or max. range shown in the DC ELECTRICAL CHARACTERISTICS OVER OPERATING RANGE table for the appropriate V<sub>CC</sub> range.  $T_A = -40^{\circ}\text{C}$  to  $+85^{\circ}\text{C}$ .

OPERATING CHARACTERISTICS,  $V_{CC} = 3.3V \pm 0.3V$ ,  $T_A = 25^\circ C$

Symbol	Parameter	Test Conditions	Typical	Unit
CPD	Power Dissipation Capacitance per Latch Outputs enabled	$C_L = 0pF$ , $f = 10Mhz$	37	pF
CPD	Power Dissipation Capacitance per Latch Outputs disabled		4	

SWITCHING CHARACTERISTICS<sup>(1)</sup>

Symbol	Parameter	$V_{CC} = 2.7V$		$V_{CC} = 3.3V \pm 0.3V$		Unit
		Min.	Max.	Min.	Max.	
t <sub>PLH</sub> t <sub>PHL</sub>	Propagation Delay xD to xQ	—	7.7	1.5	6.9	ns
t <sub>PLH</sub> t <sub>PHL</sub>	Propagation Delay LE to xQ	—	8.4	2	7.7	ns
t <sub>PZH</sub> t <sub>PZL</sub>	Output Enable Time $\overline{OE}$ to xQ	—	8.5	1.5	7.5	ns
t <sub>PHZ</sub> t <sub>PLZ</sub>	Output Disable Time $\overline{OE}$ to xQ	—	7	1.6	6.5	ns
t <sub>w</sub>	Pulse Duration LE HIGH	3.3	—	3.3	—	ns
t <sub>SU</sub>	Set-up Time, data before LE $\downarrow$	2	—	2	—	ns
t <sub>H</sub>	Hold Time, data after LE $\downarrow$	1.5	—	1.5	—	ns
t <sub>SK(0)</sub>	Output Skew <sup>(2)</sup>	—	—	—	1	ns

NOTES:

1. See TEST CIRCUITS AND WAVEFORMS.  $T_A = -40^\circ C$  to  $+85^\circ C$ .
2. Skew between any two outputs of the same package and switching in the same direction.

TEST CIRCUITS AND WAVEFORMS

TEST CONDITIONS

Symbol	V <sub>CC</sub> <sup>(1)</sup> =3.3V±0.3V	V <sub>CC</sub> <sup>(1)</sup> =2.7V	V <sub>CC</sub> <sup>(2)</sup> =2.5V±0.2V	Unit
V <sub>LOAD</sub>	6	6	2 x V <sub>CC</sub>	V
V <sub>IH</sub>	2.7	2.7	V <sub>CC</sub>	V
V <sub>T</sub>	1.5	1.5	V <sub>CC</sub> / 2	V
V <sub>LZ</sub>	300	300	150	mV
V <sub>HZ</sub>	300	300	150	mV
C <sub>L</sub>	50	50	30	pF

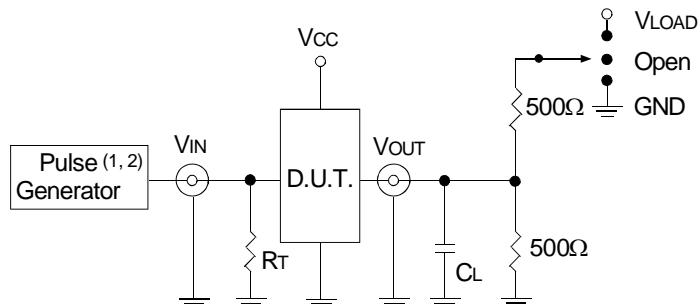

Test Circuit for All Outputs

DEFINITIONS:

C<sub>L</sub> = Load capacitance: includes jig and probe capacitance.  
R<sub>T</sub> = Termination resistance: should be equal to Z<sub>OUT</sub> of the Pulse Generator.

NOTES:

1. Pulse Generator for All Pulses: Rate ≤ 10MHz; t<sub>r</sub> ≤ 2.5ns; t<sub>r</sub> ≤ 2.5ns.
2. Pulse Generator for All Pulses: Rate ≤ 10MHz; t<sub>r</sub> ≤ 2ns; t<sub>r</sub> ≤ 2ns.

SWITCH POSITION

Test	Switch
Open Drain Disable Low Enable Low	V <sub>LOAD</sub>
Disable High Enable High	GND
All Other Tests	Open

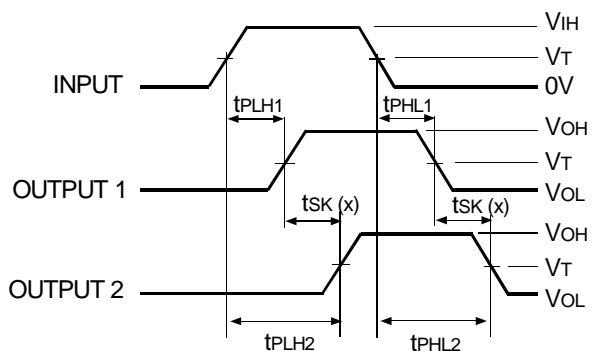

$$tsk(x) = |t_{PLH2} - t_{PLH1}| \text{ or } |t_{PHL2} - t_{PHL1}|$$

Output Skew - tsk(x)

NOTES:

1. For tsk(o) OUTPUT1 and OUTPUT2 are any two outputs.
2. For tsk(b) OUTPUT1 and OUTPUT2 are in the same bank.

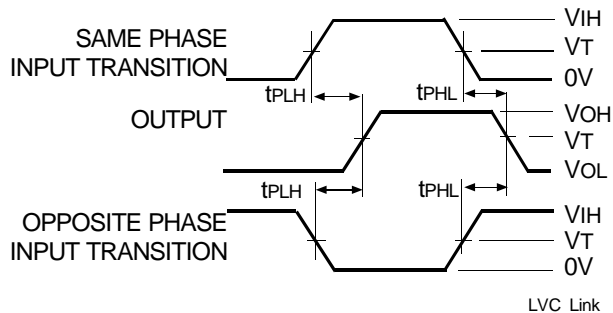

Propagation Delay

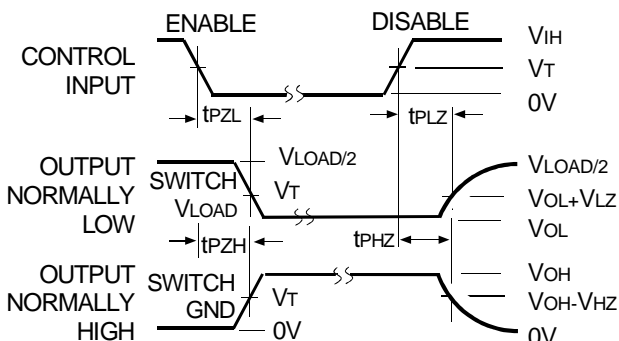

Enable and Disable Times

NOTE:

1. Diagram shown for input Control Enable-LOW and input Control Disable-HIGH.

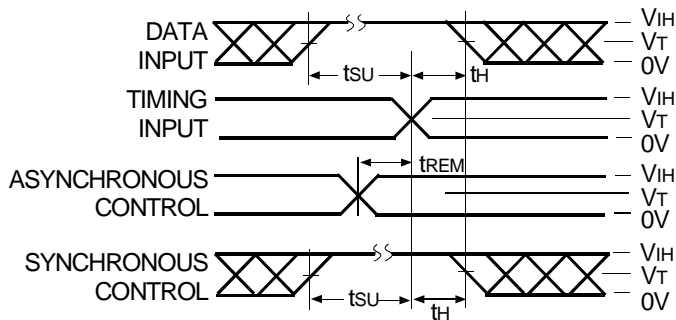

Set-up, Hold, and Release Times

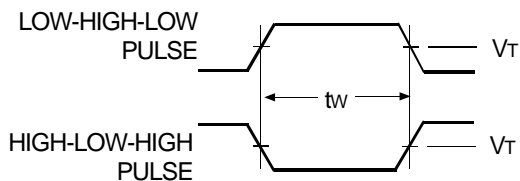

Pulse Width

**ORDERING INFORMATION**

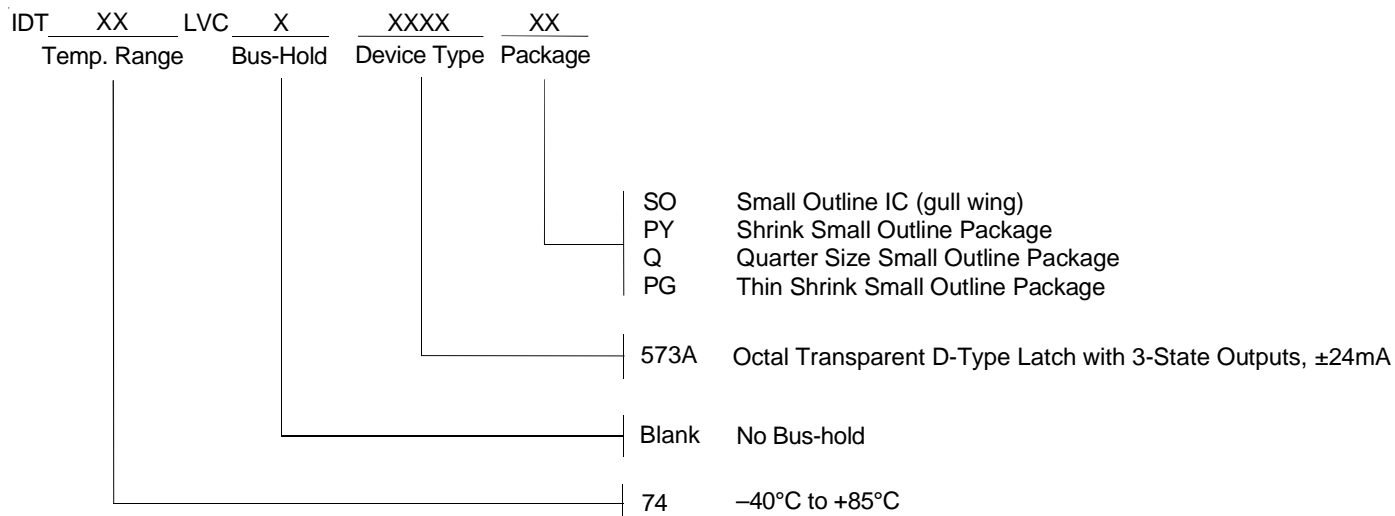

**CORPORATE HEADQUARTERS**  
 2975 Stender Way  
 Santa Clara, CA 95054

**for SALES:**  
 800-345-7015 or 408-727-6116  
 fax: 408-492-8674  
 www.idt.com

**for Tech Support:**  
 logichelp@idt.com  
 (408) 654-6459



LittleDiode supplies new, hard to find or obsolete electronic components and semiconductors all over the world.

With over two million different components listed you are sure to find the part you need.

Feel free to visit us today at our online store:

[LittleDiode.com](http://LittleDiode.com)

Looking forward to providing you with the best possible service.