

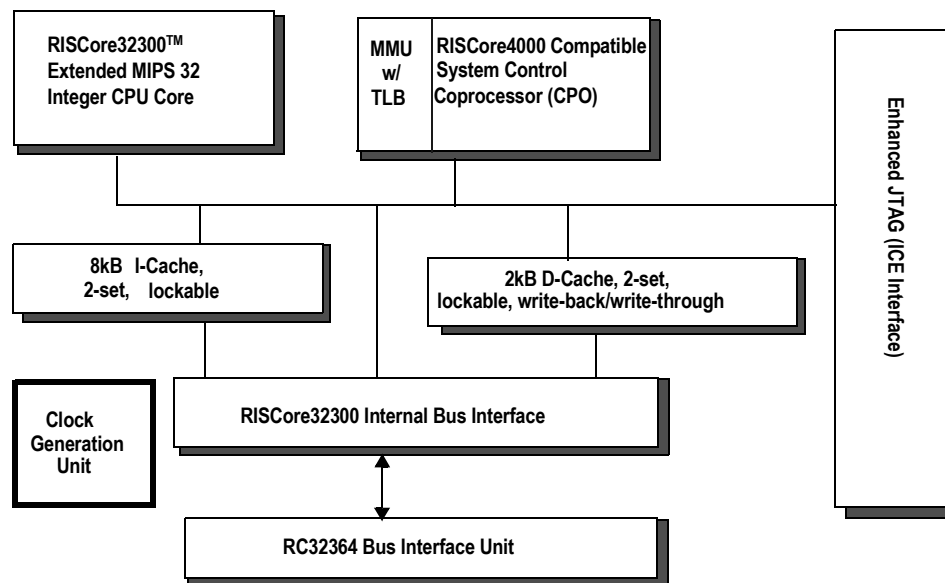

Features

- ◆ **High-performance embedded RISController™ microprocessor, based on IDT RISCore32300™ 32-bit CPU core**
 - Based on MIPS 32 RISC architecture with enhancements
 - Scalar 5-stage pipeline minimizes branch and load delays
 - 66 Million multiply accumulate (MAC) Mul-Add/second @ 133MHz
 - 100 and 133 frequencies
- ◆ **MIPS 32 (ISA) instruction set architecture**
 - MIPS IV compatible conditional move instructions
 - MIPS IV superset PREF (prefetch) instruction
 - Fast multiplier with atomic multiply-add, multiply-sub
 - Count leading zeros/ones instructions
- ◆ **Large, efficient on-chip caches**
 - Separate 8kB Instruction cache and 2kB Data cache
 - 2-way set associative
 - Write-back and write-through support on a per page basis
 - Optional cache locking with “per line” resolution, to facilitate deterministic response
 - Simultaneous instruction and data fetch in each clock cycle, sustained rate, achieves over 1 GB/sec bandwidth
- ◆ **Flexible RC4000 compatible MMU with 32-page TLB on-chip**
 - Variable page size
 - Variable number of locked entries
 - No performance penalty for address translation
- ◆ **Flexible bus interface allows simple, low-cost designs**
 - Bus interface runs at a fraction of pipeline rate
 - Programmable port-width interface (8-, 16-, 32-bit memory and I/O regions)
 - Programmable bus turnaround times (BTA)
 - Supports single data or burst transactions
- ◆ **Improved real-time support**
 - Fast interrupt decode
- ◆ **Low-power operation**
 - Active power management: powers down inactive units
 - Typical power 700mW @ 133MHz
 - Stand-by mode <300mW
- ◆ **Enhanced JTAG interface, for low-cost in-circuit emulation (ICE)**
- ◆ **MIPS architecture ensures applications software compatibility throughout the RISController series of embedded processors**
- ◆ **Industrial temperature range support**
- ◆ **3.3V operation (core and I/O)**

Block Diagram



Device Overview

Targeted to a variety of performance-hungry, cost-sensitive embedded applications, the RC32364 is a new low-powered, low-cost member of the Integrated Device Technology, Inc. (IDT) RISController Series of Embedded Microprocessors.

The RC32364 brings 64-bit performance levels to lower cost systems. High performance is achieved through the use of advanced techniques such as large on-chip two-way set-associative caches, a streamlined high-speed pipeline, high-bandwidth, and facilities such as early restart for data cache misses. Also, through IDT proprietary enhancements to the base MIPS architecture, the processor's performance, in particular applications, is further extended.

The RC32364 is the first member of a new processor family that uses IDT's proprietary RISCore32300 CPU core. The RISCore32300 core continues IDT's tradition of high-performance through high-speed pipelines, high-bandwidth caches, and architectural extensions that serve the needs of specific markets; yet the RC32364 provides these capabilities in a low-cost, high-speed 32-bit enhanced MIPS architecture core, enabling a new level of price performance.

Around the RISCore32300, the RC32364 integrates a fully RC5000 compatible memory management unit (MMU), substantial amounts of efficient cache memory, an enhanced debug capability, digital signal processing (DSP) extensions, and a low-cost system interface. The resulting device is well suited to the needs of mid-range communications equipment, xDSL equipment, and consumer devices.

Also, being upwardly software compatible with the RC3000 family, the RC32364 will serve in many of the same applications as well as support applications that require integer DSP functions.

Device Performance

RC32364 is rated at 175 dhrystone MIPS at 133MHz. The internal cache bandwidth is over 1.2 GB/sec, with external bus bandwidth of 260MB/sec. Computational performance is further enhanced by the device's DSP capability, which supports 66 Million multiply-accumulate (MAC) operations per second at 133MHz.

The **RISCore32300** uses a 5-stage pipeline, similar to the RISCore3000 and the RISCore4000 processor families. The simplicity of the pipeline enables the processor to achieve high frequency while minimizing device complexity, reducing both cost and power consumption. Because this pipeline is not sensitive to the data conflicts that slow-down super-scalar machines, an added benefit to this pipeline approach is that sustained actual performance is much closer to the theoretical maximum performance.

The **RISCore32300 integer execution unit** implements the MIPS 32 ISA. The RISCore32300 thus implements a load/store architecture with single-cycle ALU operations (logical, shift, add, subtract) and an autonomous multiply/divide unit. The 32-bit register resources include 32 general-purpose orthogonal integer registers, the HI/LO result register for the integer multiply/divide unit, and the program counter. RISCore32300 CPU core features include:

- ◆ MIPS IV prefetch operations, with various innovative hint subfields
- ◆ MIPS IV compatible conditional move instructions
- ◆ MAD, MUL and MSUB instructions added to the integer multiply units
- ◆ Two new instructions: Count Leading Ones (CLO) and Counts Leading Zeros (CLZ)

These integer unit enhancements combine to make the CPU well suited to applications that require high bandwidth, rapid computation, and/or DSP capability.

The **RISCore32300 register file** has 32 general-purpose 32-bit registers that are used for scalar integer operations and address calculation. The register file consists of two read ports and two write ports and is fully bypassed to minimize operation latency in the pipeline.

The **RISCore32300 arithmetic logic unit (ALU)** consists of the integer adder and logic unit. The adder performs address calculations in addition to arithmetic operations; the logic unit performs all of the logic and shift operations. Each unit is highly optimized and can perform an operation in a single pipeline cycle.

The RC32364 uses a dedicated **integer multiply/divide unit**, optimized for high-speed multiply and multiply-accumulate operations. Table 1 lists the repeat rate (peak issue rate of cycles until the operation can be reissued), latency (number of cycles until a result is available), and number of processor stalls (number of cycles that the CPU will always delay the pipeline) required for these operations. Each rate listed is expressed in terms of pipeline clocks.

Opcode	Operand Size	Latency	Repeat	Stall
MULT/U, MAD/U MSUB/U	16 bit	3	2	0
	32 bit	4	3	0
MUL	16 bit	3	2	1
	32 bit	4	3	2
DIV, DIVU	any	36	36	0

Table 1 RISCore32300 Integer Multiply/Divide Unit Operation Frequency

The original MIPS architecture defines that the results of a multiply or divide operation are placed in the HI and LO registers. Using the move-from-HI (MFHI) and move-from-LO (MFLO) instructions, these values can then be transferred to the general purpose register file.

As an enhancement to the original MIPS ISA, the RC32364 implements an additional multiply instruction, MUL, which specifies that multiply results bypass the LO register and be placed immediately into the primary register file. By avoiding the explicit MFLO instruction, required when using LO, and by supporting multiple destination registers, the throughput of multiply-intensive operations is increased.

Two atomic operations—multiply-add (MAD) and multiply-subtract (MSUB)—are used to perform the multiply-accumulate and multiply-subtract operations. The MAD instruction multiplies two numbers and then adds the product to the current contents of the HI and LO registers. Similarly, the MSUB instruction multiplies two operands and then subtracts the product from the HI and LO registers.

The MAD and MSUB operations are used in numerous DSP algorithms and allow the RC32364 to cost reduce systems requiring a mix of DSP and control functions.

Finally, for these operations, aggressive implementation techniques feature low latency along with pipelining to allow the issuance of new operations before a previous operation has been completed. The RC32364 also performs automatic operand size detection and implements hardware interlocks to prevent overrun, achieving high-performance with simple programming.

System Control Coprocessor (CP0)

In the MIPS architecture, the system control co-processor is responsible for the virtual-to-physical address translation and cache protocols, the exception control system, and the processor's diagnostics capability. Also, the system control co-processor (and thus the kernel software) is implementation dependent.

Although the RISC32300 implements a 32-bit ISA, the Memory Management Unit (MMU) that the RC32364 incorporates is modeled after the MMU found in the 64-bit RC5000 family and offers variable page size, enhanced cache write algorithm support, mapping of a larger portion of the virtual address space and a variable number of locked entries, relative to the traditional 32-bit R3000 style MMU.

The RC32364's translation lookaside buffer (TLB) contains 16 entries, mapping a total of 32 pages or as much as 512 MB of memory at a time.

The exception model that is implemented in the RC32364 is also consistent with that of the RC5000 family, including the treatment of kernel mode and exception processing.

The RC32364 incorporates all **system control co-processor (CP0)** registers on-chip. These registers provide the path through which the virtual memory system's address translation is controlled, exceptions are handled, and operating modes are selected (for example, kernel vs. user mode, interrupts enabled or disabled, and cache features).

In addition, the RC32364 includes registers to implement a real-time cycle counting facility, which aids in cache diagnostic testing, assists in data error detection, and facilitates software debug. Alternatively, this timer can be used as the operating system reference timer and can signal a periodic interrupt.

Operation Modes

The RC32364 supports two modes of operation: user mode and kernel mode. User mode is most often used for applications programs, and the kernel mode is typically used for handling exceptions and operating system kernel functions, including CP0 management and I/O device access.

The processor enters kernel mode at reset and when an exception is recognized. While in kernel mode, software has access to the entire address space as well as all of the CP0 registers. User mode accesses are limited to a subset of the virtual address space and can be inhibited from accessing CP0 functions.

Virtual-to-Physical Address Mapping

The RC32364's 4GB virtual address space is divided into addresses that are accessible in either kernel or user mode (kuseg) and those that are accessible only in kernel mode (kseg2:0).

Bits in a status register determine which virtual addressing mode will be used. While in user mode, the RC32364 provides a single, uniform 2GB virtual address space for the user's program. While operating in kernel mode, four distinct virtual address spaces, totalling 4GB, are simultaneously available and are differentiated by the high-order bits of the virtual address.

The RC32364 reserves a small portion of the kernel address space for on-chip resources. These resources include those used by the Enhanced JTAG unit as well as registers used to configure the system bus interface.

For fast virtual-to-physical address decoding, the RC32364 uses a fully associative **translation lookaside buffer (TLB)** that maps 32 virtual pages to their corresponding physical addresses. The TLB is organized as 16 pairs of even/odd entries mapping pages of sizes that vary from 4kBytes to 16 MBytes into the 4GB physical address space.

To assist in controlling both the amount of mapped space and the replacement characteristics of various memory regions, the RC32364 provides two mechanisms. First, the page size can be configured, on a per entry basis, to map a page size of 4kB to 16MB (in multiples of 4). A CP0 register is loaded with the mapping page size which is then entered into the TLB when a new entry is written. Thus, operating systems can provide special purpose maps; for example, a typical frame buffer can be memory mapped with only one TLB entry.

The second mechanism controls the replacement algorithm, when a TLB miss occurs. To select a TLB entry to be written with a new mapping, the RC32364 provides a random replacement algorithm; however, the processor provides a mechanism whereby a system specific number of mappings can be locked into the TLB and thus avoid being randomly replaced. This facilitates the design of real-time systems, by allowing deterministic access to critical software.

The RC32364's TLB also contains information to control the cache coherency protocol for each page. Specifically, each page has attribute bits to determine whether the coherency algorithm is uncached, non-coherent write-back, or non-coherent write-through no write-allocate.

This allows the system architect to allocate address space according to the most efficient use of bus bandwidth. For example, stack data may be accessed always as write-back, while packet data may be best accessed as write through, for later DMA out to an I/O port.

The RC32364 cache controller works in conjunction with these attributes, enabling an application to alias a region of physical memory through multiple virtual spaces. The cache controller will also ensure that regardless of which address space is used the current copy of data will be provided when referenced, and it will further guarantee that the cache is properly managed with respect to main memory.

Debug Support

To facilitate software debug, the RC32364 adds a pair of watch registers to CP0. When enabled, these registers will cause the CPU to take an exception when a “watched” address is appropriately accessed.

In addition, the RC32364 implements an Enhanced JTAG interface, which requires the inclusion of significant amounts of debug support logic on-chip, facilitating the development of low-cost in-circuit emulation equipment.

For low-cost In-Circuit Emulation, the RC32364 provides an **Enhanced JTAG interface**. This interface consists of two modes of operation: Run-Time Mode and Real-Time Mode.

The Run-Time Mode provides a standard JTAG interface for on-chip debugging, and the Real-Time Mode provides additional status pins—PCST[2:0]—which are used in conjunction with JTAG pins for Real-Time Trace information at the processor internal clock or any division of the pipeline clock.

The RC32364 implements the traditional RC4000 model of **interrupt processing**. However, this model has been enhanced to benefit real-time systems.

To speed interrupt exception decoding, the RC32364 adds a separate interrupt vector. Unlike the RC3000 family—which utilizes a single common exception vector for all exception types (including interrupts)—the RC32364 allows kernel software to enable a separate interrupt exception vector.

When enabled, this vector location speeds interrupt processing by allowing software to avoid decoding interrupts from general purpose exceptions.

Development Tools

An array of tools facilitate rapid development of RC32364-based systems, allowing a wide variety of customers to take advantage of the processor’s high-performance capabilities while maintaining short time-to-market goals.

The RC32364 incorporates an enhanced JTAG debug interface. This interface uses a small number of pins, combined with on-chip debug support logic, to enable the development of low-cost in-circuit emulators for high-speed IDT processors.

Cache Memory

To keep the RC32364’s high-performance pipeline full and operating efficiently, the RC32364 incorporates on-chip instruction and data caches that can each be accessed in a single processor cycle. Each cache has its own 32-bit data path and can be accessed in the same pipeline clock cycle.

The RC32364 incorporates a two-way set associative on-chip **Instruction Cache**. This virtually indexed, physically tagged cache is 8kB in size and parity protected. Because this cache is virtually indexed, the virtual-to-physical address translation occurs in parallel with the cache access. The tag holds a 21-bit physical address, a valid bit, lock bit, a parity bit, and the FIFO replacement bit.

For fast, single cycle data access, the RC32364 includes a 2kB on-chip **data cache** that is two-way set associative with a fixed 16-byte (four words) line size. The data cache is protected with byte parity and its tag is protected with a single parity bit. It is virtually indexed and physically tagged to allow simultaneous address translation and data cache access.

The RC32364 supports a **cache-locking** feature to critical sections of code and data into on-chip caches, to guarantee fast accesses. The implementation of cache-locking is on a “per-line” basis, enabling the system designer to maximize the efficiency of the system cache.

Writes to external memory—whether cache miss write-backs or stores to uncached or write-through addresses—use the **on-chip write buffer**. The write buffer holds a maximum of four address and data pairs. The entire buffer is used for a data cache writeback and allows the processor to proceed in parallel with a memory update.

System interfaces

The RC32364 supports a 32-bit system interface, allowing the CPU to interface with a lower cost memory system. The main features of the system interface include:

- ◆ Multiplexed address and data bus with Address Latch Enable (ALE) signal to demultiplex the A/D bus.
- ◆ Support of variable port widths, including boot device.
- ◆ Support of multiple pipeline to system clock ratios, with the CPU core frequency being derived from the input system clock.
- ◆ Incorporation of a DMA arbiter, allowing an external master control of the external bus.

The 32-bit **system address/data (A/D)** bus is used to transfer addresses and data between the RC32364 and the rest of the system. The ALE signal is provided to demultiplex the address from this bus. The DATAEN* signal indicates the data phase of the A/D bus and DT/R* indicates the direction of data flow. BE*[3:0] indicates the valid bytes on the bus. Additional ADDR[3:2] provides incremental address during burst transfers.

To indicate system interface bus activity, the RC32364 provides a cycle-in-progress (CIP*) signal. The RD* and WR* signals indicate the type of cycle in progress. And to terminate cycle in progress, the

RC32364 also provides Ack*, Retry*, and BusErr* signals. This device also provides I/D* signals, to indicate whether instructions or data is being transferred. The Last* signal is provided to indicate that the last data transfer is in progress.

The RC32364 provides six **external interrupt signals**: INT*[5:0] and a non-maskable interrupt (NMI*) signal.

To share the system interface bus, the RC32364 provides BusReq* and BusGnt* signals to interface **external DMA masters**. To allow the external master control of the external bus, a DMA arbiter is provided.

The RC32364 supports a **variable bus width interface**, enabling the CPU to operate with a mix of 8-bit, 16-bit, and 32-bit wide memories.

To indicate the width of the memory or I/O space being accessed, the RC32364 provides two output signals, Width[1:0]. The width of various address spaces is programmed using the Port Width Control Register. The RC32364's physical memory is divided into several regions, and each region's width can be programmed by using this register. Within these regions, the bus turnaround time can also be programmed.

Thus, the RC32364 can be simply mated with low-cost external memory subsystems. The large on-chip caches and the early restart serve to allow the processor to achieve high-performance even with such low-cost memory.

The RISCORE32300 offers a number of features relevant to low-power systems, including low-power design, active **power management** and power-down modes of operation. The RISCORE32300 is a static design. The RC32364 supports a WAIT instruction which is designed to signal the rest of the chip that execution and clocking should be halted, reducing system power consumption during idle periods.

Thermal Considerations

The RC32364 is a low-power CPU, consuming approximately 0.9W peak power. Thus, no special packaging considerations are required.

The RC32364 is guaranteed in a case temperature range of 0° to +85° C, for commercial temperature devices; - 40° to +85° for industrial temperature devices. The type of package, speed (power) of the device, and airflow conditions affect the equivalent ambient temperature conditions that will meet this specification.

The equivalent allowable ambient temperature, TA, can be calculated using the thermal resistance from case to ambient (θ_{CA}) of the given package. The following equation relates ambient and case temperatures:

$$T_A = T_C - P * \theta_{CA}$$

where P is the maximum power consumption at hot temperature, calculated by using the maximum ICC specification for the device.

Typical values for θ_{CA} at various airflows are shown in Table 2 Note that the RC32364 implements advanced power management, which substantially reduces the average power dissipation of the device.

Airflow (ft/min)	θ_{CA}					
	0	200	400	600	800	1000
144 TQFP	27	22	20	17	15	14

Table 2 Thermal Resistance (θ_{CA}) at Various Airflows

Revision History

August 1999: Changed references from MIPS-II to MIPS 32. Changed references from MIPS-IV to MIPS 64. Changed values in Clock Parameters Table, System Interface Parameters Table, and Power Consumption Table. Deleted Several Timing Diagrams. Added JTAG Timing Diagram.

Jan. 12, 2000: Corrected information regarding the TRST* signal in Table 3. TRST* requires an external pull-down on the board.

April 4, 2000: Adjusted values for DCLK in the System Interface Parameters table. Added Power Curves.

June 20, 2000: Changed times for the Data Output Hold, TDO Output Delay Time, and TPC Output Delay Time parameters in the System Interface Parameters table. Revised values for PCST Output Delay Time in System Interface Parameters table.

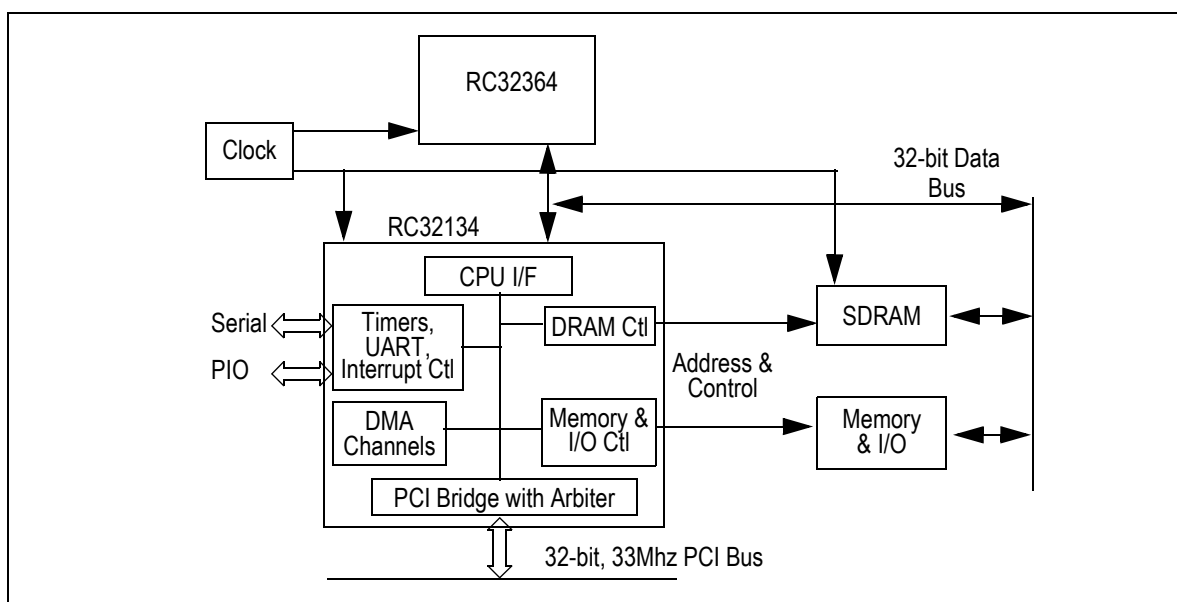

Figure 1 System Block Diagram

Pin Description Table

The following is a list of the system interface pins available on the RC32364. Pin names ending with an asterisk (*) are active when low.

Pin	Type	Description																														
System Interface																																
AD(31:4)	I/O	Addr(31:4)/Data(31:4) High-order multiplexed address and data bits. Regardless of system byte ordering, AD(31) is the MSB of the address.																														
AD(3:0)	I/O	Size(3:0)/Data(3:0) Valid sizes for the RC32364 are as follows: <table border="1" style="margin: 10px auto;"> <thead> <tr> <th>Size(3)</th> <th>Size(2)</th> <th>Size(1)</th> <th>Size(0)</th> <th>Transfer Width</th> </tr> </thead> <tbody> <tr> <td>0</td> <td>0</td> <td>0</td> <td>0</td> <td>16 bytes</td> </tr> <tr> <td>0</td> <td>0</td> <td>0</td> <td>1</td> <td>1 byte</td> </tr> <tr> <td>0</td> <td>0</td> <td>1</td> <td>0</td> <td>2 bytes</td> </tr> <tr> <td>0</td> <td>0</td> <td>1</td> <td>1</td> <td>3 bytes</td> </tr> <tr> <td>0</td> <td>1</td> <td>0</td> <td>0</td> <td>4 bytes</td> </tr> </tbody> </table> <p>Other encodings allow future generations to service other transfer sizes. During the data phase, AD[3:0] represents the Data(3:0).</p>	Size(3)	Size(2)	Size(1)	Size(0)	Transfer Width	0	0	0	0	16 bytes	0	0	0	1	1 byte	0	0	1	0	2 bytes	0	0	1	1	3 bytes	0	1	0	0	4 bytes
Size(3)	Size(2)	Size(1)	Size(0)	Transfer Width																												
0	0	0	0	16 bytes																												
0	0	0	1	1 byte																												
0	0	1	0	2 bytes																												
0	0	1	1	3 bytes																												
0	1	0	0	4 bytes																												
Addr(3:2)	O	Addr(3:2) Non-multiplexed address lines. These serve as the word within block address for cache refills (Addr(3:2)). The word within block address bits count in a sub-block ordering.																														
ALE	O	Address Latch Enable. This signal provides set-up and hold times around the address phase of the AD bus.																														
ADS*	O	Address Strobe This active-low signal indicates valid address and the start of a new bus transaction. The processor asserts ADS* for the entire address cycle. This is the inverse of the ALE signal.																														

Table 3 System Interface Pin Descriptions (Page 1 of 4)

Pin	Type	Description																									
Width(1:0)	0	<p>Bus Width Indicates the Physical Memory/IO data bus size as follows:</p> <table border="1"> <thead> <tr> <th>Width(1)</th> <th>Width(0)</th> <th>Port Width</th> </tr> </thead> <tbody> <tr> <td>0</td> <td>0</td> <td>8 bits</td> </tr> <tr> <td>0</td> <td>1</td> <td>16 bits</td> </tr> <tr> <td>1</td> <td>0</td> <td>32 bits</td> </tr> <tr> <td>1</td> <td>1</td> <td>Reserved</td> </tr> </tbody> </table>	Width(1)	Width(0)	Port Width	0	0	8 bits	0	1	16 bits	1	0	32 bits	1	1	Reserved										
Width(1)	Width(0)	Port Width																									
0	0	8 bits																									
0	1	16 bits																									
1	0	32 bits																									
1	1	Reserved																									
BE*(3:0)	0	<p>ByteEnables(3:0)/Addr(1:0) Indicates which byte lanes are expected to participate in the transfer.</p> <table border="1"> <thead> <tr> <th colspan="5">Byte Lanes Enabled In Data Transfer</th> </tr> <tr> <th>Port Width</th> <th>BE(3)</th> <th>BE(2)</th> <th>BE(1)</th> <th>BE(0)</th> </tr> </thead> <tbody> <tr> <td>32-bit</td> <td>Used</td> <td>Used</td> <td>Used</td> <td>Used</td> </tr> <tr> <td>16-bit</td> <td>Byte High Enable</td> <td>Not Used</td> <td>Address Bit 1 (A1)</td> <td>Byte Low Enable</td> </tr> <tr> <td>8-bit</td> <td>Not Used (Driven High)</td> <td>Not Used (Driven High)</td> <td>Address Bit 1 (A1)</td> <td>Address Bit 0 (A0)</td> </tr> </tbody> </table>	Byte Lanes Enabled In Data Transfer					Port Width	BE(3)	BE(2)	BE(1)	BE(0)	32-bit	Used	Used	Used	Used	16-bit	Byte High Enable	Not Used	Address Bit 1 (A1)	Byte Low Enable	8-bit	Not Used (Driven High)	Not Used (Driven High)	Address Bit 1 (A1)	Address Bit 0 (A0)
Byte Lanes Enabled In Data Transfer																											
Port Width	BE(3)	BE(2)	BE(1)	BE(0)																							
32-bit	Used	Used	Used	Used																							
16-bit	Byte High Enable	Not Used	Address Bit 1 (A1)	Byte Low Enable																							
8-bit	Not Used (Driven High)	Not Used (Driven High)	Address Bit 1 (A1)	Address Bit 0 (A0)																							
CIP*	0	<p>Cycle-in-progress Denotes that a cycle is in progress. Asserted in the address phase and continue asserted until the ACK* for the last data is sampled.</p>																									
I/D*	0	<p>I/D* Indicates that the current cycle is for an instruction (active high) or data (active low) transaction.</p>																									
Rd*	0	<p>Read This active-low signal indicates that the current transaction is a read.</p>																									
Wr*	0	<p>Write This active-low signal indicates that the current cycle transaction is a write.</p>																									
DataEn*	0	<p>Data Enable This active-low signal indicates that the AD bus is in data cycle. DEN* is asserted after the address cycle (starting of data cycle), and deasserted at the end of the last data cycle.</p>																									
DT/R*	0	<p>Data Transmit/Receive This active-low signal indicates the current cycle transaction of data direction. "High" is for a write cycle and "Low" is for a read cycle.</p>																									
Ack*	1	<p>Acknowledge Receiving Data On read transactions, this signal indicates to the RC32364 that the memory system has placed valid data on the A/D bus, and that the processor may move the data into the on-chip Read Buffer. On a write transaction, this indicates to the RC32364 that the memory system has accepted the data on the A/D bus.</p>																									
Last*	0	<p>Last Data This active-low output is used to indicate the last data phase of a transfer.</p>																									

Handshake Interface

BusErr*	1	<p>Bus Error Indicates that a bus error has occurred.</p>
---------	---	---

Table 3 System Interface Pin Descriptions (Page 2 of 4)

Pin	Type	Description
Retry*	I	Retry Indicates that the current bus cycle must be terminated. Retry* is ignored after acceptance of the first data during a read cycle. During a write, Retry* is recognized in all data cycles.

Initialization Interface

ColdReset*	I	ColdReset This active-low signal is used for power-on reset.
Reset*	I	Reset This active-low signal is used for both power-on and warm reset.

DMA Interface

BusReq*	I	Bus Request This active-low signal is an input to the processor that is used to request mastership of the external interface bus. Mastership is granted according to the assertion of this input, taken back based on its negation.
BusGnt*	I/O	Bus Grant/ModeBit(5) This active-low signal is an output from the processor and is used to indicate that the CPU has relinquished mastership of the external interface bus. BusGnt* goes low initially for at least 2 clocks to indicate that the CPU has relinquished mastership of the external interface bus. After going low, BusGnt* returns high, either when the CPU makes an internal request for the bus or after BusReq* is de-asserted. During the power-on reset (Cold Reset), BusGnt* is an input, ModeBit(5).

Interrupt Interface

NMI*	I	Non-Maskable Interrupt NMI is falling edge sensitive and an asynchronous signal.
Int*(5:0)	I	Interrupt/ModeBit(9:6) These interrupt inputs are active low to the CPU. During power-on, Int*(3:0) serves as ModeBit(9:6).

Debug Emulator Interface

TCK	I	Testclock An input test clock, used to shift into or out of the Boundary-Scan register cells. TCK is independent of the system and the processor clock with nominal 50% duty cycle.
TDI/DINT*	I	TDI/DINT* On the rising edge of TCK, serial input data are shifted into either the Instruction or Data register, depending on the TAP controller state. During Real Mode, this input is used as an interrupt line to stop the debug unit from Real Time mode and return the debug unit back to Run Time Mode (standard JTAG). Requires an external pull-up on the board.
TDO/TPC	O	TDO/TPC The TDO is serial data shifted out from instruction or data register on the falling edge of TCK. When no data is shifted out, the TDO is tri-stated. During Real Time Mode, this signal provides a non-sequential program counter at the processor clock or at a division of processor clock.
TMS	I	TMS The logic signal received at the TMS input is decoded by the TAP controller to control test operation. TMS is sampled on the rising edge of the TCK. Requires an external pull-up on the board.
TRST*	I	TRST* The TRST* pin is an active-low signal for asynchronous reset of the debug unit, independent of the processor logic. Requires an external pull-down on the board.
DCLK	O	DCLK Processor Clock. During Real Time Mode, this signal is used to capture address and data from the TDO signal at the processor clock speed or any division of the internal pipeline.

Table 3 System Interface Pin Descriptions (Page 3 of 4)

Pin	Type	Description
PCST(2:0)	I/O	PCST(2:0)/ModeBit(2:0) PC Trace Status Information 111 (STL) Pipe line Stall 110 (JMP) Branch/Jump forms with PC output 101 (BRT) Branch/Jump forms with no PC output 100 (EXP) Exception generated with an exception vector code output 011 (SEQ) Sequential performance 010 (TST) Trace is outputted at pipeline stall time 001 (TSQ) Trace trigger output at performance time 000 (DBM) Run Debug Mode During power-on reset (cold reset), PCST(2:0) serves as ModeBit(2:0).
PCST(4:3)	I/O	PCST(4:3)/ModeBit(4:3) PC Trace Status Information. Reserved Pins for future expansion. During power-on reset, PCST(4:3) serves as ModeBit(4:3).
DebugBoot	I	DebugBoot The Debug Boot input is used during reset and forces the CPU core to take a debug exception at the end of the reset sequence instead of a reset exception. This enables the CPU to boot from the ICE probe without having the external memory working. This input signal is level sensitive and is not latched internally. This signal will also set the JtagBrk bit in the JTAG_Control_Register[12].

Clock/Control Interface

MasterClk	I	MasterClock This input clock is the bus clock. The core frequency is derived by multiplying this clock up.
VccP	I	VccP Quiet Vcc for PLL.
VssP	I	VssP Quiet Vss for PLL.
Vcc I/O	I	Supply voltage for output buffers.
Vcc Core	I	Supply voltage for internal logic.
Vss	I	Ground.

Table 3 System Interface Pin Descriptions (Page 4 of 4)

Logic Diagram

Figure 2 illustrates the direction and functional groupings for the processor signals of the RC32364.

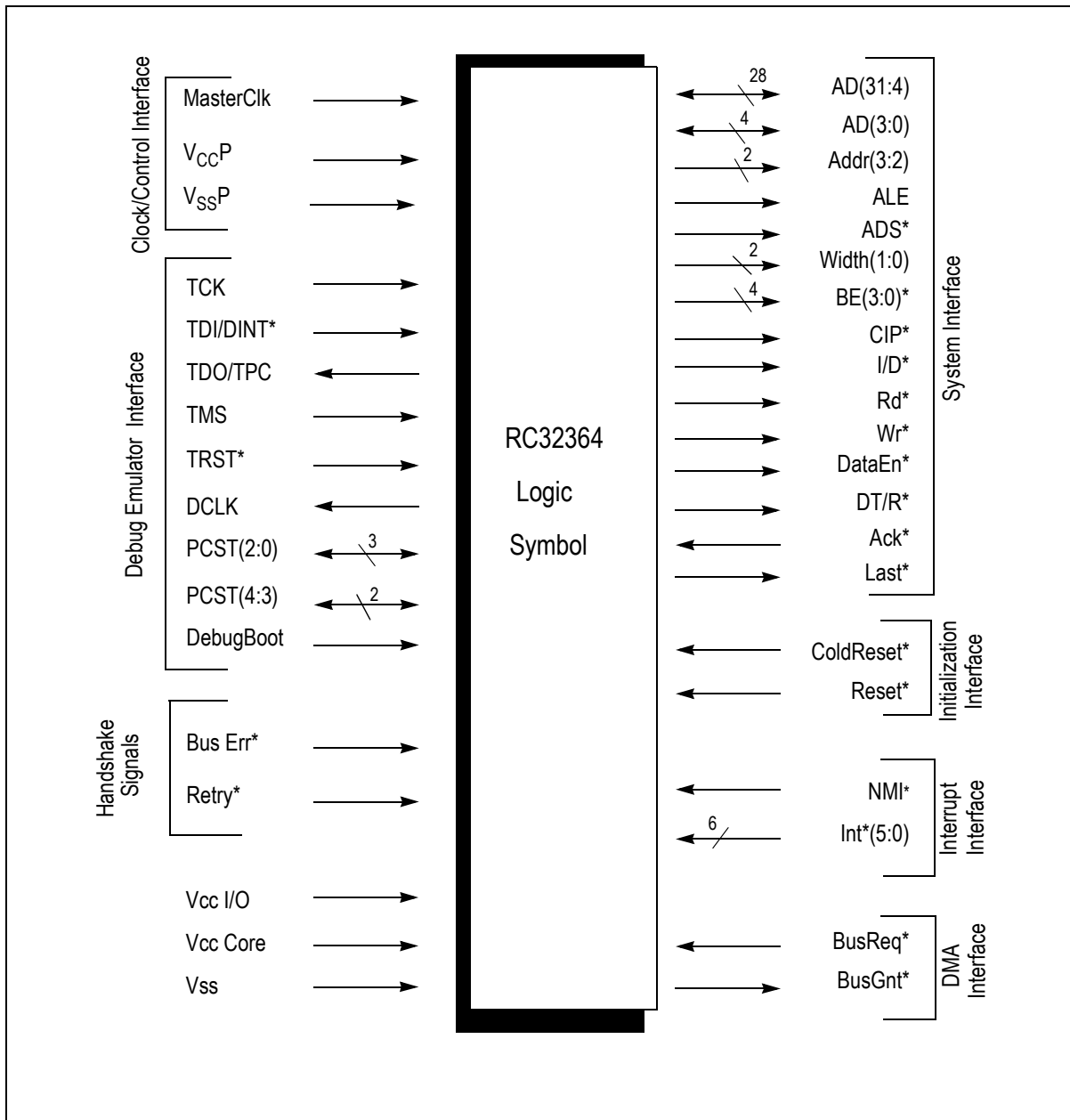

Figure 2 Logic Diagram for RC32364

RC32364 144-pin TQFP Package Pin-Out

Note that the asterisk (*) identifies an active-low pin. For maximum flexibility and future design compatibility, N.C. pins should be left floating.

Pin	Function	Pin	Function	Pin	Function	Pin	Function
1	Vcc I/O	37	NC	73	NC	109	NC
2	Vss	38	NC	74	NC	110	CIP*
3	TRST*	39	NC	75	NC	111	AD28
4	TDO/TPC*	40	NC	76	ADS*	112	Vss
5	TMS	41	Addr3	77	AD16	113	Vcc I/O
6	Vcc I/O	42	Vcc I/O	78	Vss	114	AD3
7	Vss	43	Vss	79	Vcc I/O	115	AD27
8	TCK	44	AD10	80	AD15	116	DataEn*
9	TDI/DINT*	45	ADDR2	81	I/D*	117	AD4
10	DebugBoot	46	BusReq*	82	VssP	118	Vss
11	PCST4	47	AD11	83	VccP	119	Vcc I/O
12	Vcc Core	48	Vcc I/O	84	NC	120	AD26
13	Vss	49	Vss	85	NC	121	AD5
14	PCST3	50	AD20	86	NC	122	DT/R*
15	NMI*	51	BE3	87	NC	123	AD25
16	INT0*	52	ColdReset*	88	MasterClk	124	Vss
17	PCST2	53	BusGNT*	89	Vss	125	Vcc Core
18	Vcc I/O	54	AD12	90	Vcc I/O	126	AD6
19	Vss	55	Vcc Core	91	AD31	127	AD24
20	DClk	56	Vss	92	AD0	128	AD7
21	INT1*	57	AD19	93	Ack*	129	AD23
22	Vcc Core	58	BE2	94	ALE	130	Vss
23	INT2*	59	Width1	95	Vss	131	Vcc I/O
24	Reset*	60	AD13	96	Vcc Core	132	AD8
25	Vcc Core	61	Vcc I/O	97	AD30	133	Vss
26	Vss	62	Vss	98	AD1	134	AD22
27	Wr*	63	AD18	99	Vcc Core	135	AD9
28	Rd*	64	BE1	100	BusErr*	136	Vss
29	PCST1	65	Width0	101	Retry*	137	Vcc I/O
30	INT3*	66	AD14	102	AD29	138	AD21
31	Vcc I/O	67	Vcc I/O	103	Vss	139	NC
32	Vss	68	Vss	104	Vcc I/O	140	NC
33	INT4*	69	AD17	105	AD2	141	NC
34	PCST0	70	BE0	106	Last*	142	Vss
35	INT5*	71	NC	107	NC	143	NC
36	NC	72	NC	108	NC	144	NC

Absolute Maximum Ratings

Note: Stresses greater than those listed under ABSOLUTE MAXIMUM RATINGS may cause permanent damage to the device. This is a stress rating only and functional operation of the device at these or any other conditions above those indicated in the operational sections of this specification is not implied. Exposure to absolute maximum rating conditions for extended periods may affect reliability.

Symbol	Rating	RC32364 3.3V±5%	RC32364 3.3V±5%	Unit
		Commercial	Industrial	
V _{TERM}	Terminal Voltage with respect to GND	-0.5 ¹ to 4.0	-0.5 ¹ to 4.0	V
T _C	Operating Temperature(case)	0 to +85	-40 to +85	°C
T _{BIAS}	Case Temperature Under Bias	-55 to +125	-55 to +125	°C
T _{STG}	Storage Temperature	-55 to +125	-55 to +125	°C
I _{IN}	DC Input Current	20 ²	20 ²	mA
I _{OUT}	DC Output Current	50 ³	50 ³	mA

¹ V_{IN} minimum = -2.0V for pulse width less than 15ns. V_{IN} should not exceed V_{CC} +0.5 Volts.

² When V_{IN} < 0V or V_{IN} > V_{CC}

³ Not more than one output should be shorted at a time. Duration of the short should not exceed 30 seconds.

Recommended Operation Temperature and Supply Voltage

Grade	Temperature	Gnd	RC32364 V _{CC} Core & V _{CC} I/O
Commercial	0°C to +85°C (Case)	0V	3.3V±5%
Industrial	-40°C + 85°C (Case)	0V	3.3V±5%

AC Electrical Characteristics — Commercial/Industrial Temperature Ranges—RC32364

V_{CC} Core & V_{CC} I/O = 3.3V ± 5%; T_{Case} = 0°C to +85°C Commercial, T_{Case} = -40°C to +85°C Industrial

Clock Parameters—RC32364

Note: Operation of the RC32364 is only guaranteed with the Phase Lock Loop enabled

Parameter	Symbol	Test Conditions	RC32364 100MHz		RC32364 133MHz		Units
			Min	Max	Min	Max	
Pipeline clock frequency	PClk		80	100	80	133	MHz
MasterClock HIGH	t _{MCHIGH}	Transition ≤ 2ns	6	—	5	—	ns
MasterClock LOW	t _{MLOW}	Transition ≤ 2ns	6	—	5	—	ns
MasterClock Frequency	—	—	10	50	10	67	MHz
MasterClock Period	t _{MCP}	—	20	100	15	100	ns
Clock Jitter for MasterClock ¹	t _{JitterIn} ¹	—	—	±250	—	±250	ps
MasterClock Rise Time ²	t _{MCRise}	—	—	3	—	3	ns
MasterClock Fall Time ²	t _{MCFall}	—	—	3	—	3	ns
JTAG Clock Period	t _{TCK}	—	100	—	100	—	ns
JTAG Clock High and Low Time	t _{TCKLOW} , t _{TCKHIGH}	—	40	—	40	—	ns
JTAG Clock Fall and Rise Time	t _{TCKFall} , t _{TCKRise}	—	—	3	—	3	ns

¹ Guaranteed by design

² Rise and Fall times are measured between 10% and 90%.

System Interface Parameters—RC32364

Parameter	Symbol	Test Conditions	RC32364 100MHz		RC32364 133MHz		Units
			Min	Max	Min	Max	
Data Output	$t_{DO} = \text{Max}$		—	6	—	6	ns
Data Output Hold	t_{DOH}		0.7	—	0.7	—	ns
Data Output for ALE	t_{DOA}		—	6	—	6	ns
Data Setup	t_{DS}	$t_{rise} = 2\text{ns}$ $t_{fall} = 2\text{ns}$	3	—	3	—	ns
Data Setup Special: Ack, Retry, BusErr	t_{DSS}		6	—	5	—	ns
Data Hold	t_{DH}		0.5	—	0.5	—	ns
JTAG Clock Period	t_{TCK}, t_3		100	—	100	—	ns
DCLK Clock Period	t_{DCK}, t_{11}		12.5	—	12.5	—	ns
DCLK High, Low Time	$t_{DCK \text{ High}}, t_9$ $t_{DCK \text{ Low}}, t_{10}$		2.5	—	2.5	—	ns
DCLK Rise, Fall Time	$t_{DCK \text{ Rise}}, t_{15}$ $t_{DCK \text{ Fall}}, t_{15}$		—	3.5	—	3.5	ns
TDO Output Delay Time	t_{TDODO}, t_4		—	6	—	6	ns
TDI Input Setup Time	t_{TDIS}, t_5		4	—	4	—	ns
TDI Input Hold Time	t_{TDIH}, t_6		2	—	2	—	ns
TPC Output Delay Time	t_{TPCDO}, t_8		-1	6	-1	6	ns
PCST Output Delay Time	t_{PCSTDO}, t_7		-1	6	-1	6	ns
TRST* Low Time	$t_{TRSTLow}, t_{12}$		100	—	100	—	ns
TRST* Removal Time	t_{TRSTR}, t_{13}		3	—	3	—	ns

DC Electrical Characteristics — Commercial/Industrial Temperature Ranges—RC32364

V_{CC} Core & V_{CC} I/O = $3.3V \pm 5\%$; $T_{Case} = 0^\circ\text{C}$ to $+85^\circ\text{C}$ Commercial, $T_{Case} = -40^\circ\text{C}$ to $+85^\circ\text{C}$ Industrial

Parameter	RC32364 100MHz		RC32364 133MHz		Conditions
	Min	Max	Min	Max	
V_{OL}	—	0.1V	—	0.1V	$ I_{OUT} = 20\mu\text{A}$
V_{OH}	$V_{CC} - 0.1V$	—	$V_{CC} - 0.1V$	—	
V_{OL}	—	0.4V	—	0.4V	$ I_{OUT} = 4\text{mA}$
V_{OH}	2.4V	—	2.4V	—	
V_{IL}	-0.5V	$0.2V_{CC}$	-0.5V	$0.2V_{CC}$	—
V_{IH}	$0.7V_{CC}$	$V_{CC} + 0.3V$	$0.7V_{CC}$	$V_{CC} + 0.3V$	—
C_{IN}	—	10pF	—	10pF	—
C_{OUT}	—	10pF	—	10pF	—
I/O_{LEAK}	—	20 μA	—	20 μA	Input/Output Leakage

Output Loading For AC Testing

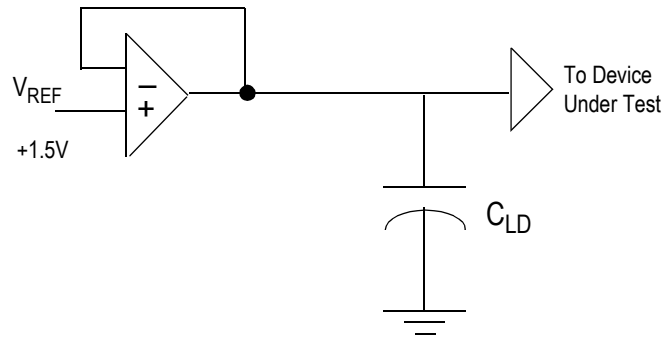

Figure 3 Output Loading for AC Testing

Signal	C _{ld}
All Signals	50 pF

Power Consumption — RC32364

Parameter		RC32364 100MHz		RC32364 133MHz		Conditions
		Typical	Maximum	Typical	Maximum	
System Condition:		100/50MHz		133/67MHz		—
I _{CC}	standby ¹	50mA	90mA	50mA	90mA	C _L = 50pF T _C = 25°C V _{CC} core & V _{CC} I/O = 3.65V
	active	160mA	180mA	200mA	250mA	C _L = 50pF T _C = 25°C V _{CC} core, V _{CC} I/O = 3.65V
P	power dissipation	0.58W	0.6W	0.7Watt	0.9	C _L = 50pF T _C = 25°C V _{CC} core, V _{CC} I/O = 3.65V

¹. Executing wait instruction

Capacitive Load Deration — RC32364

Parameter	Symbol	Test Conditions	100MHz		133MHz		Units
			Min	Max	Min	Max	
Load Derate	C _{LD}	—	—	2	—	2	ns/25pF

Power Curves

The following two graphs contain power curves that show power consumption at various bus frequencies.

Note: Only pipeline frequencies that are integer multiples (2x, 3x, etc.) of bus frequencies are supported.

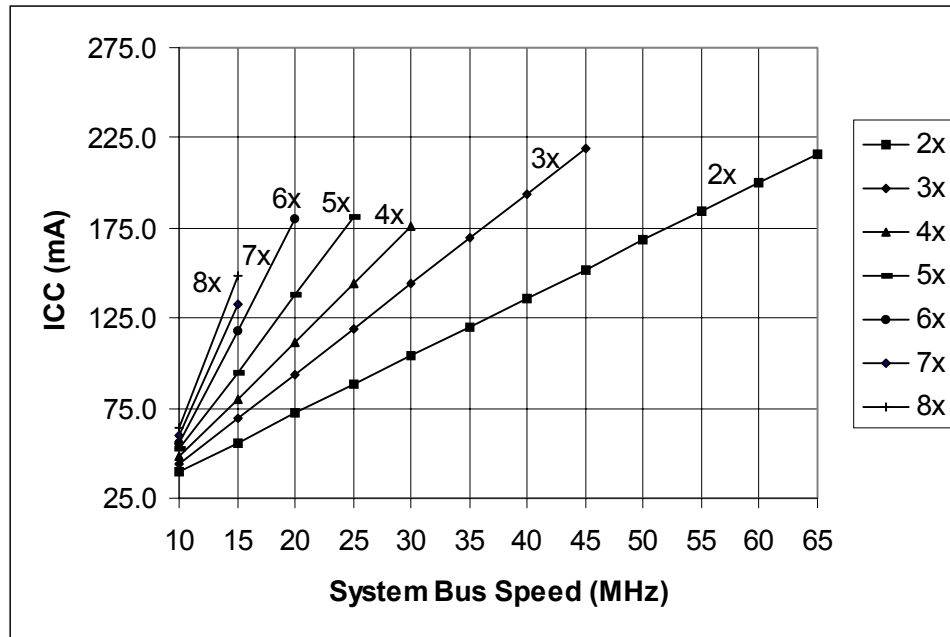

Figure 4 Typical Power Usage - RC32364

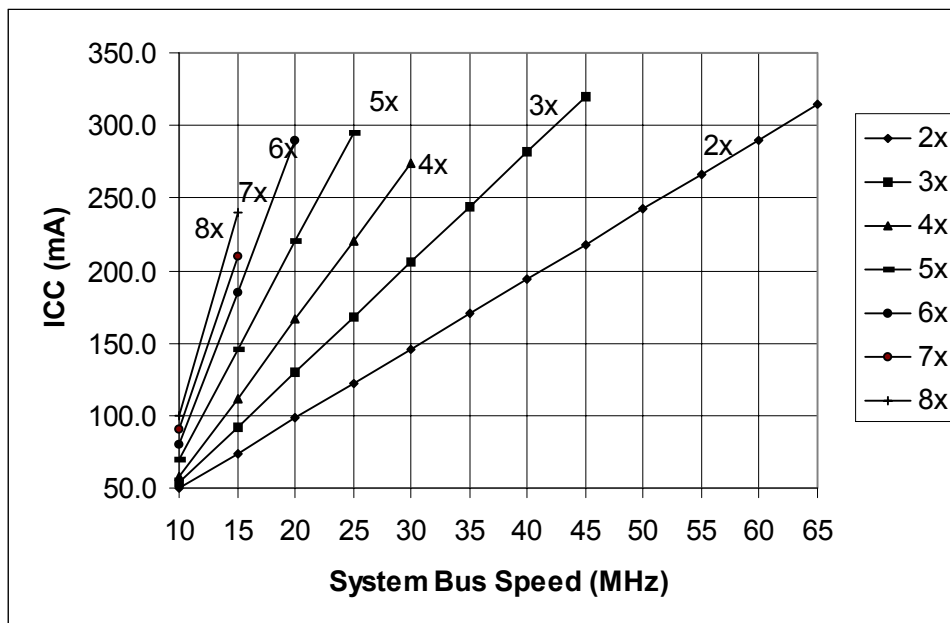

Figure 5 Maximum Power Usage - RC32364

Timing Characteristics — RC32364

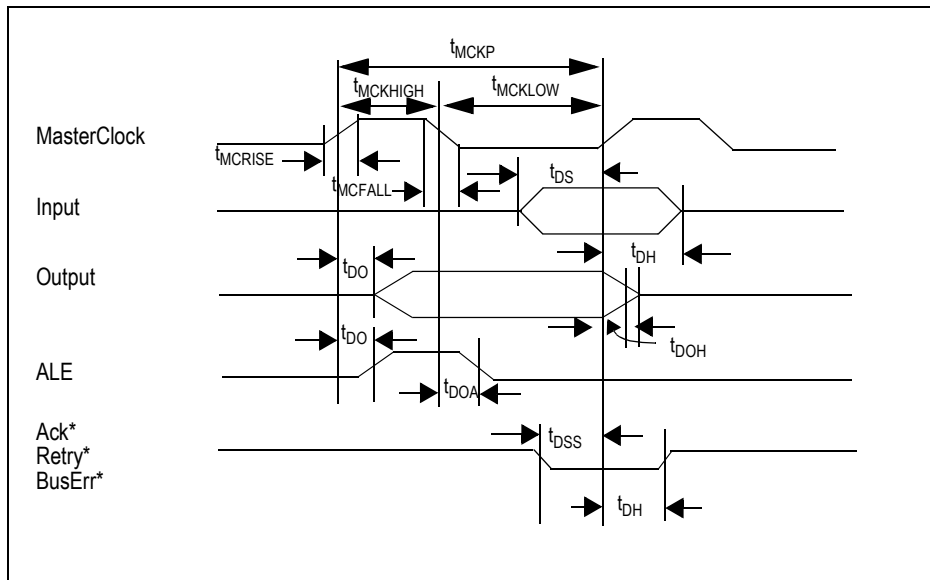

Figure 6 System Clocks Data Setup, Output, and Hold timing

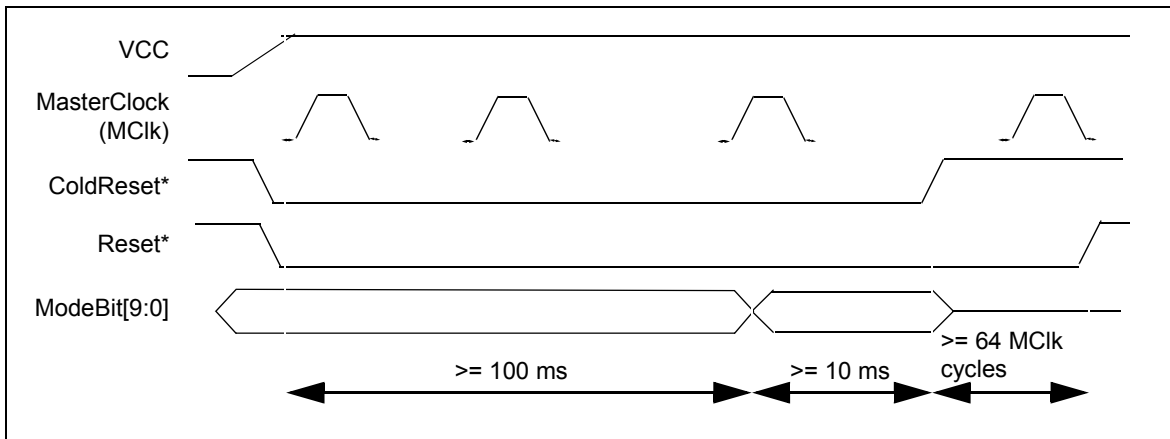

Figure 7 Mode Configuration Interface Reset Sequence

Standard JTAG Timing

Figure 8 represents the timing diagram for the EJTAG interface signals.

The standard JTAG connector is a 10-pin connector providing 5 signal and 5 ground pins. For Enhanced JTAG, a 24-pin connector has been chosen providing 12 signal pins and 12 ground pins. This guarantees the elimination of noise problems by incorporating a signal-ground type arrangement.

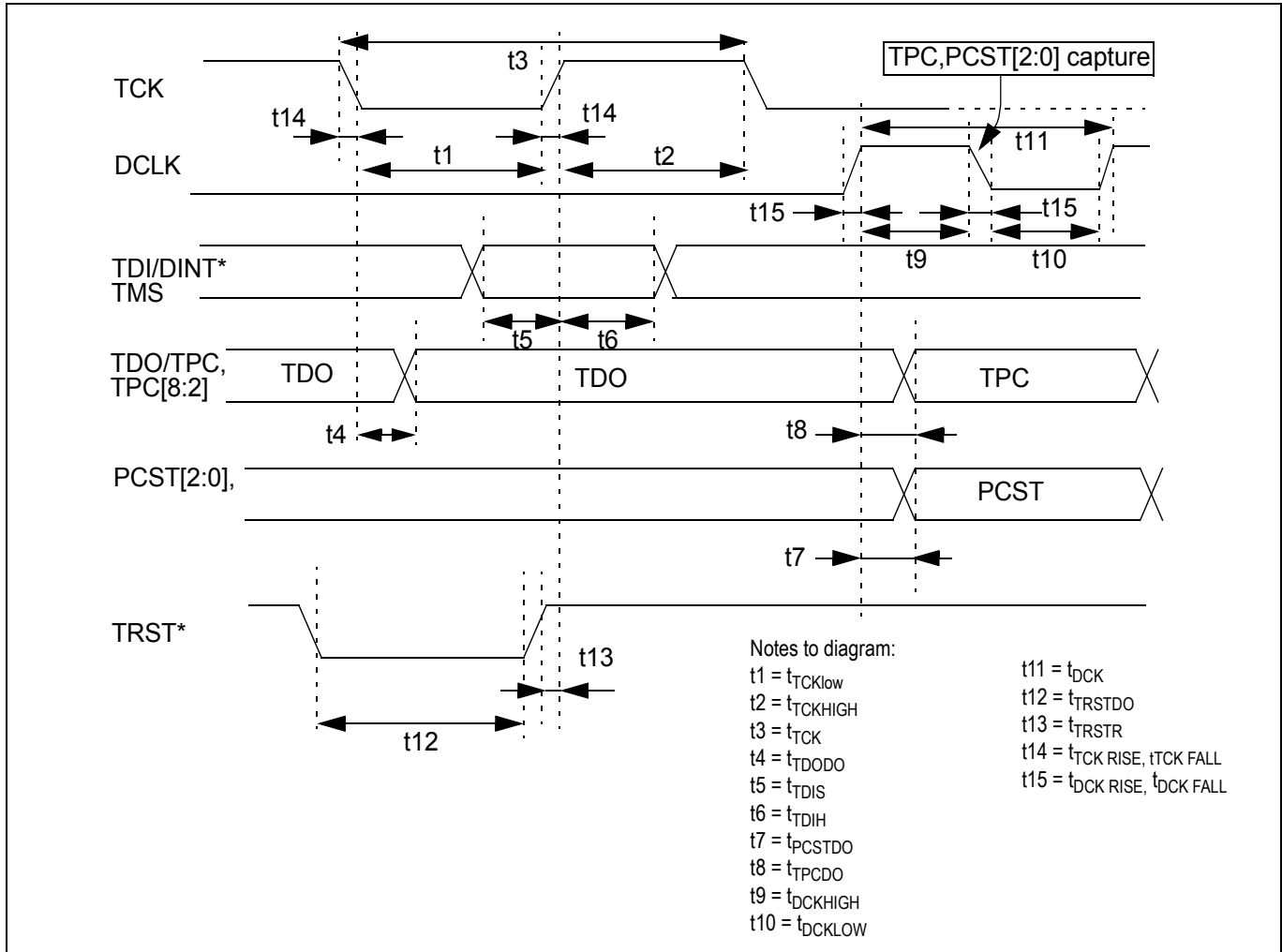

Figure 8 Standard JTAG timing

Table 4 shows the pin numbering for the Standard EJTAG (EJT) connector. All the even numbered pins are connected to GROUND. The two right-hand most columns show the target signal direction and the recommended termination at the target. Target termination resistors may be internal to the chip or external on the board.

PIN	SIGNAL	TARGET I/O	TERMINATION ¹
1	TRST* (optional)	Input	10 k Ω pull-down resistor
3	TDI/DINT*	Input	10 k Ω pull-up resistor
5	TDO/TPC	Output	33 Ω series resistor
7	TMS	Input	10 k Ω pull-up resistor
9	TCK	Input	10 k Ω pull-up resistor ²
11	RST*	Input	10 k Ω pull-up resistor
13	PCST[0]	Output	33 Ω series
15	PCST[1]	Output	33 Ω series
17	PCST[2]	Output	33 Ω series
19	DCLK	Output	33 Ω series
21	Debugboot	Input	10 k Ω pull-down resistor
23	VIO	Input	Must be connected to the VCC IO supply of the device.

Table 4 Pin Numbering of the JTAG and EJTAG Target Connector

¹. The value of the series resistor may depend on the actual PCB layout situation.

². TCK pull-up resistor is not required according to the JTAG (IEEE1149) standard. It is indicated here to prevent a floating CMOS input when the EJTAG connector is unconnected.

RC32364 Package Drawing — 144-pin TQFP

(Note: The RC32364 is available in a 144-pin thin quad flat pack (TQFP) package.)

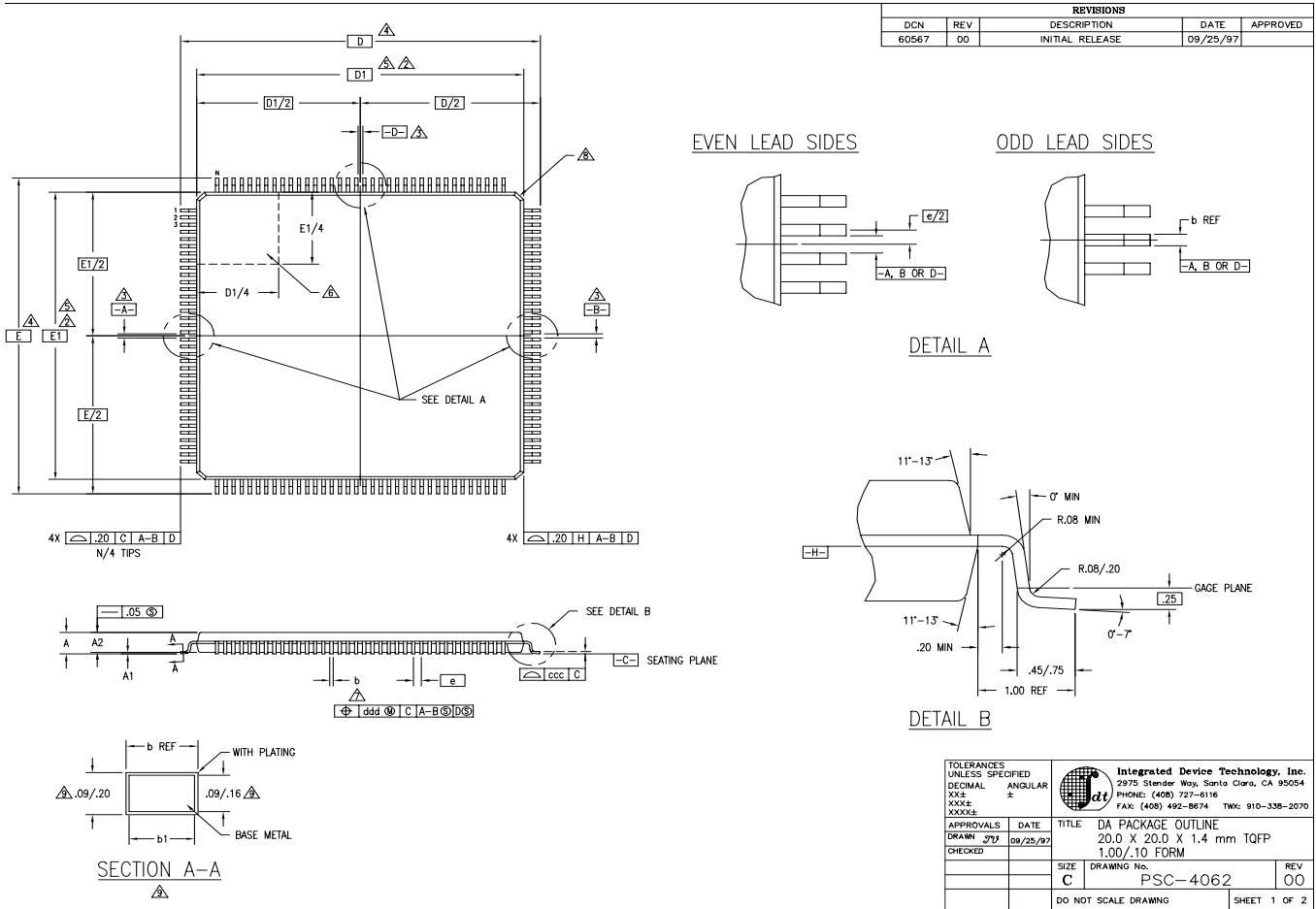

REVISIONS				
DCN	REV	DESCRIPTION	DATE	APPROVED
60567	00	INITIAL RELEASE	09/25/97	

TOLERANCES UNLESS SPECIFIED		Integrated Device Technology, Inc. 2975 Stender Way, Santa Clara, CA 95054 PHONE: (408) 727-0116 FAX: (408) 492-8674 TWX: 910-338-2070
DECIMAL	ANGULAR	
XXX±	±	
APPROVALS	DATE	TITLE
DRAWN 379	09/25/97	DA PACKAGE OUTLINE
CHECKED		20.0 X 20.0 X 1.4 mm TQFP
		1.00/.10 FORM
SIZE	DRAWING No.	REV
C	PSC-4062	00
DO NOT SCALE DRAWING		SHEET 1 OF 2

RC32364 Package Drawing — Page Two

REVISIONS				
DCN	REV	DESCRIPTION	DATE	APPROVED
60567	00	INITIAL RELEASE	09/25/97	

SYMBOL	JEDEC VARIATION			NOTE
	BFB			
	MIN	NOM	MAX	
A	-	-	1.60	
A1	.05	-	.15	
A2	1.35	1.40	1.45	
D	22.00 BSC			4
D1	20.00 BSC			5,2
E	22.00 BSC			4
E1	20.00 BSC			5,2
N	144			
e	.50 BSC			
b	.17	-	.27	7
b1	.17	.20	.23	
ddd	-	-	.08	

NOTES:

- 1 ALL DIMENSIONING AND TOLERANCING CONFORM TO ANSI Y14.5M-1982
- ⚠ TOP PACKAGE MAY BE SMALLER THAN BOTTOM PACKAGE BY .15 mm
- ⚠ DATUMS [A-B] AND [-D-] TO BE DETERMINED AT DATUM PLANE [-H-]
- ⚠ DIMENSIONS D AND E ARE TO BE DETERMINED AT SEATING PLANE [-C-]
- ⚠ DIMENSIONS D1 AND E1 DO NOT INCLUDE MOLD PROTRUSION. ALLOWABLE MOLD PROTRUSION IS .25 mm PER SIDE. D1 AND E1 ARE BODY SIZE DIMENSIONS INCLUDING MOLD MISMATCH
- ⚠ DETAIL OF PIN 1 IDENTIFIER IS OPTIONAL BUT MUST BE LOCATED WITHIN THE ZONE INDICATED
- ⚠ DIMENSION b DOES NOT INCLUDE DAMBAR PROTRUSION. ALLOWABLE DAMBAR PROTRUSION IS .08 mm IN EXCESS OF THE b DIMENSION AT MAXIMUM MATERIAL CONDITION. DAMBAR CANNOT BE LOCATED ON THE LOWER RADIUS OR THE FOOT.
- ⚠ EXACT SHAPE OF EACH CORNER IS OPTIONAL
- ⚠ THESE DIMENSIONS APPLY TO THE FLAT SECTION OF THE LEAD BETWEEN .10 AND .25 mm FROM THE LEAD TIP
- 10 ALL DIMENSIONS ARE IN MILLIMETERS
- 11 THIS OUTLINE CONFORMS TO JEDEC PUBLICATION 95 REGISTRATION MS-026, VARIATION BFB

LAND PATTERN DIMENSIONS

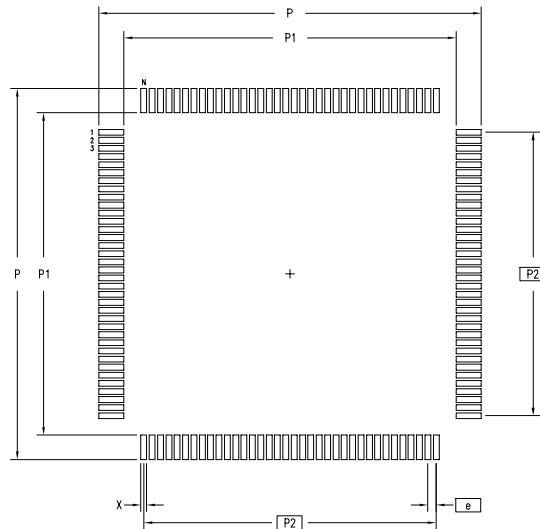

	MIN	MAX
P	22.80	23.00
P1	19.80	20.00
P2	17.50 BSC	
X	.30	.40
e	.50 BSC	
N	144	

TOLERANCES UNLESS SPECIFIED		 Integrated Device Technology, Inc. 2975 Steiner Way, Santa Clara, CA 95054 PHONE: (408) 727-6116 FAX: (408) 492-8674 TWX: 910-338-2070
DECIMAL	ANGULAR	
XXX±	±	
XXXX±		
APPROVALS	DATE	TITLE
DRAWN 377	09/25/97	DA PACKAGE OUTLINE
CHECKED		20.0 X 20.0 X 1.4 mm TQFP
		1.00/10 FORM
SIZE	DRAWING No.	REV
C	PSC-4062	00
DO NOT SCALE DRAWING		SHEET 2 OF 2

Ordering Information

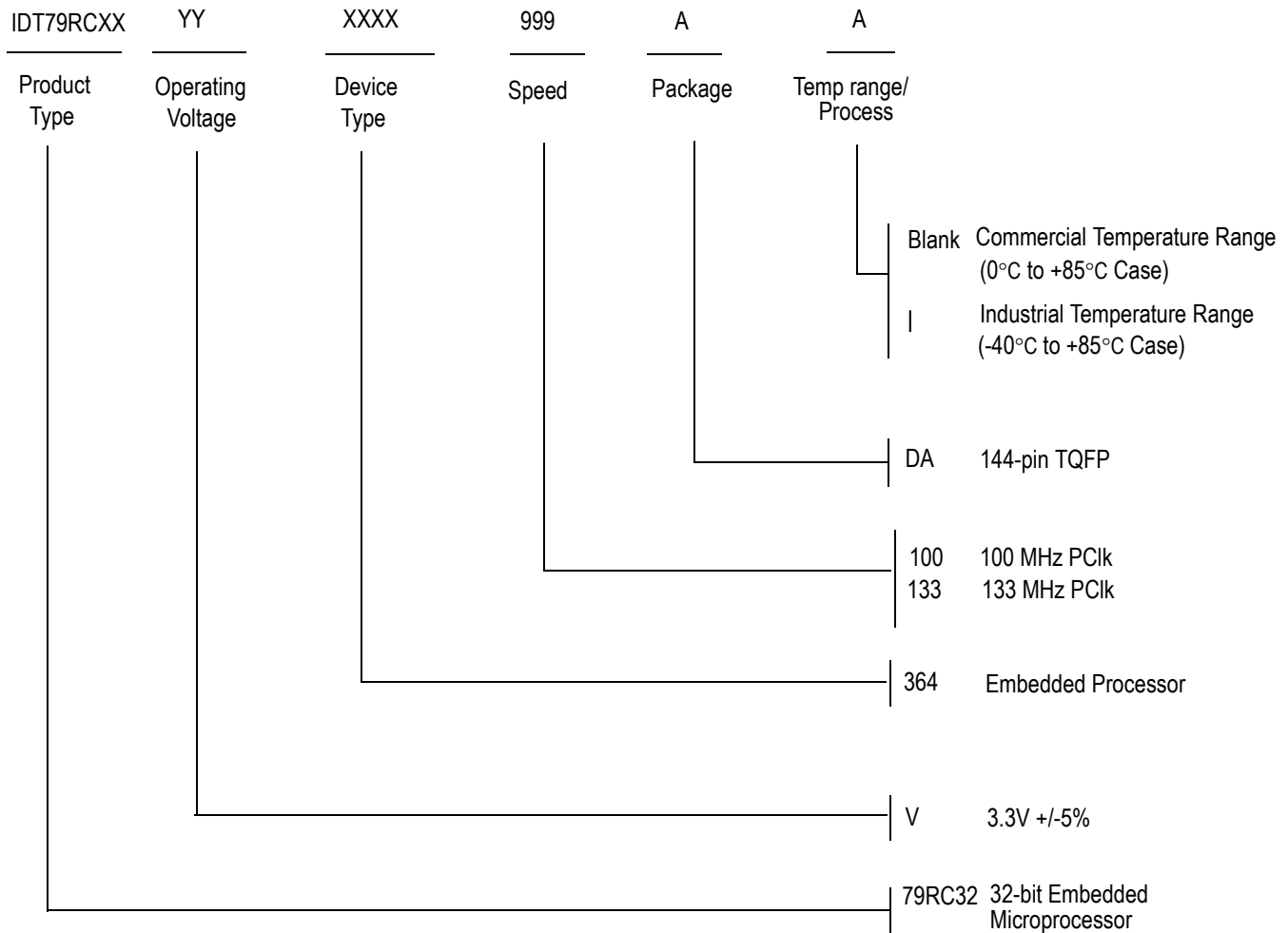

Valid Combinations

IDT79RC32V364 - 100,133 DA
IDT79RC32V364 - 100,133 DAI

TQFP package, Commercial Temperature
TQFP package, Industrial Temperature



CORPORATE HEADQUARTERS
2975 Stender Way
Santa Clara, CA 95054

for SALES:
800-345-7015 or 408-727-6116
fax: 408-330-1748
www.idt.com

for Tech Support:
email: rischelp@idt.com
phone: 408-492-8208

The IDT logo is a registered trademark of Integrated Device Technology, Inc.



LittleDiode supplies new, hard to find or obsolete electronic components and semiconductors all over the world.

With over two million different components listed you are sure to find the part you need.

Feel free to visit us today at our online store:

LittleDiode.com

Looking forward to providing you with the best possible service.