

**OBSOLETE PRODUCT
POSSIBLE SUBSTITUTE PRODUCT
DG408, DG508A, HI-0508(A)**

April 1999

8-Channel CMOS Analog Multiplexer

Features

- Ultra Low Leakage - $I_{D(OFF)} \leq 100\mu A$ (Typ)
- $r_{DS(ON)} < 400\Omega$ Over Full Signal and Temperature Range
- Power Supply Quiescent Current Less Than $100\mu A$
- $\pm 14V$ Analog Signal Range
- No SCR Latchup
- Break-Before-Make Switching
- Binary Address Control (3 Address Inputs Control 8 Channels)
- TTL and CMOS Compatible Strobe Control
- Pin Compatible with DG508A, HI-508 and ADG508A
- Internal Diode in Series with V_+ for Fault Protection

Description

The IH6108 is a CMOS 1-of-8 multiplexer. The part is a plug-in replacement for the DG508A. Three-line decoding is used so that the 8 channels can be controlled by 3 Address inputs; additionally a fourth input is provided for use as a system enable. When the ENABLE input is high (5V), a channel is selected by the three Address inputs, and when low (0V) all channels are off. The 3 Address inputs are TTL and CMOS logic compatible, with a "1" corresponding to any voltage greater than 2.4V.

Part Number Information

PART NUMBER	TEMP. RANGE (°C)	PACKAGE	PKG. NO.
IH6108MJE	-55 to 125	16 Ld CERDIP	F16.3
IH6108MJE/883B	-55 to 125	16 Ld CERDIP	F16.3
IH6108CJE	0 to 70	16 Ld CERDIP	F16.3
IH6108CPE	0 to 70	16 Ld PDIP	E16.3

Pinout

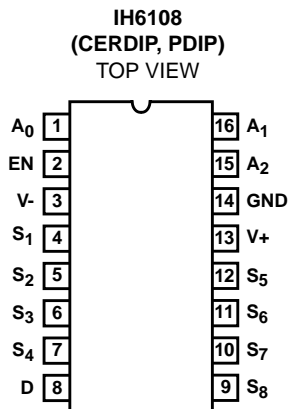

Functional Diagram

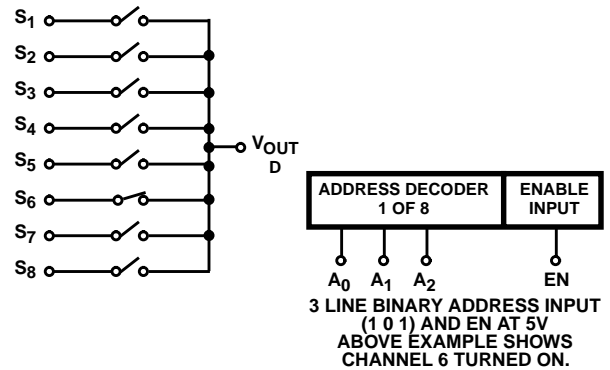

TRUTH TABLE

A ₂	A ₁	A ₀	EN	ON SWITCH
x	x	x	0	None
0	0	0	1	1
0	0	1	1	2
0	1	0	1	3
0	1	1	1	4
1	0	0	1	5
1	0	1	1	6
1	1	0	1	7
1	1	1	1	8

NOTE: A₀, A₁, A₂
Logic "1" = $V_{AH} \geq 2.4V$, $V_{ENH} \geq 4.5V$
Logic "0" = $V_{AL} \leq 0.8V$.

IH6108

Absolute Maximum Ratings

V_{IN} (A, EN) to Ground	-15V to 15V
V_S or V_D to V_+	0V, -36V
V_S to V_D to V_-	0V, 36V
V_+ to Ground	18V
V_- to Ground	-18V
Current (Any Terminal)	30mA
Current (Analog Source or Drain)	20mA

Thermal Information

Thermal Resistance (Typical, Note 1)	θ_{JA} (°C/W)	θ_{JC} (°C/W)
PDIP Package	100	N/A
CERDIP Package	75	20
Maximum Junction Temperature (Hermetic Package)	175°C	
Maximum Junction Temperature (Plastic Package)	150°C	
Maximum Storage Temperature Range	-65°C to 150°C	
Maximum Lead Temperature (Soldering 10s)	300°C	

Operating Conditions

Temperature Range

C Suffix	0°C to 70°C
M Suffix	-55°C to 125°C

CAUTION: Stresses above those listed in "Absolute Maximum Ratings" may cause permanent damage to the device. This is a stress only rating and operation of the device at these or any other conditions above those indicated in the operational sections of this specification is not implied.

NOTE:

- θ_{JA} is measured with the component mounted on an evaluation PC board in free air.

CAUTION: Stresses above those listed in "Absolute Maximum Ratings" may cause permanent damage to the device. This is a stress only rating and operation of the device at these or any other conditions above those indicated in the operational sections of this specification is not implied.

Electrical Specifications $V_+ = 15V$, $V_- = -15V$, $V_{EN} = +5V$, Ground = 0V, Unless Otherwise Specified, (Note 4)

PARAMETER	MEASURED TERMINAL	NO TESTS PER TEMP	TYP 25°C	TEST CONDITIONS	M SUFFIX (°C)			C SUFFIX (°C)			UNITS
					-55	25	125	0	25	70	
SWITCH											
$r_{DS(ON)}$	S to D	8	180	$V_D = +10V$, $I_S = -1.0mA$ Sequence Each Switch On $V_{AL} = 0.8V$, $V_{AH} = 2.4V$	300	300	400	350	350	450	Ω
		8	150	$V_D = -10V$, $I_S = -1.0mA$ Sequence Each Switch On $V_{AL} = 0.8V$, $V_{AH} = 2.4V$	300	300	400	350	350	450	Ω
$\Delta r_{DS(ON)}$			20	$\Delta r_{DS(ON)} = \frac{r_{DS(ON)MAX} - r_{DS(ON)MIN}}{r_{DS(ON)AVG}}$ $V_S = \pm 10V$	-	-	-	-	-	-	%
$I_{S(OFF)}$	S	8	0.002	$V_S = 10V$, $V_D = -10V$	-	± 0.5	± 50	-	± 1	± 50	nA
		8	0.002	$V_S = -10V$, $V_D = 10V$, $V_{EN} = 0.8V$	-	± 0.5	± 50	-	± 1	± 50	nA
$I_{D(OFF)}$	D	1	0.03	$V_D = 10V$, $V_S = -10V$, $V_{EN} = 0.8V$	-	± 2	± 100	-	± 5	± 100	nA
		1	0.03	$V_D = -10V$, $V_S = 10V$, $V_{EN} = 0.8V$	-	± 2	± 100	-	± 5	± 100	nA
$I_{D(ON)}$	D	8	0.1	$V_{S(ALL)} = V_D = 10V$, Sequence Each Switch On $V_{AL} = 0.8V$, $V_{AH} = 2.4V$	-	± 2	± 100	-	± 5	± 100	nA
		8	0.1	$V_{S(ALL)} = V_D = -10V$, Sequence Each Switch On $V_{AL} = 0.8V$, $V_{AH} = 2.4V$	-	± 2	± 100	-	± 5	± 100	nA
INPUT											
$I_{AN(ON)}$ or $I_{A(on)}$	A ₀ , A ₁ , or A ₂ Inputs A ₀ , A ₁ , A ₂	3	0.01	$V_A = 0V$	-	-10	-30	-	-10	-30	μA
$I_{AN(OFF)}$ $I_{A(off)}$		3	0.01	$V_A = 14V$	-	10	30	-	10	30	μA
I_A		3	0.01	$V_{EN} = 5V$, All $V_A = 0V$ (Address Pins)	-	-10	-30	-	-10	-30	μA
	EN	1	0.01	$V_{EN} = 0V$, All $V_A = 0V$ (Address Pins)	-	-10	-30	-	-10	-30	μA

IH6108

Electrical Specifications $V_+ = 15V$, $V_- = -15V$, $V_{EN} = +5V$, Ground = 0V, Unless Otherwise Specified, (Note 4) (Continued)

PARAMETER	MEASURED TERMINAL	NO TESTS PER TEMP	TYP 25°C	TEST CONDITIONS	M SUFFIX (°C)			C SUFFIX (°C)			UNITS
					-55	25	125	0	25	70	
DYNAMIC											
$t_{\text{TRANSITION}}$	D		0.3	See Figure 1	-	1	-	-	-	-	μs
t_{OPEN}	D		0.2	See Figure 2	-	-	-	-	-	-	μs
$t_{\text{ON(EN)}}$	D		0.6	See Figure 3	-	1.5	-	-	-	-	μs
$t_{\text{OFF(EN)}}$	D		0.4	See Figure 3	-	1	-	-	-	-	μs
"OFF" Isolation	D		60	$V_{\text{EN}} = 0V$, $R_L = 200\Omega$, $C_L = 3pF$, $V_S = 3V_{\text{RMS}}$, $f = 500\text{kHz}$	-	-	-	-	-	-	dB
$C_{\text{S(OFF)}}$	S		5	$V_S = 0V$, $V_{\text{EN}} = 0V$, $f = 140\text{kHz}$ to 1MHz	-	-	-	-	-	-	pF
$C_{\text{D(OFF)}}$	D		25	$V_D = 0V$, $V_{\text{EN}} = 0V$, $f = 140\text{kHz}$ to 1MHz	-	-	-	-	-	-	pF
$C_{\text{DS(OFF)}}$	D to S		1	$V_S = 0V$, $V_D = 0V$, $V_{\text{EN}} = 0V$, $f = 140\text{kHz}$ to 1MHz	-	-	-	-	-	-	pF
SUPPLY											
Positive Supply Current	V_+	1	40	$V_{\text{EN}} = 5V$, All $V_A = 0V$ or 5V	-	-	200	-	-	1000	μA
Negative Supply Current	V_-	1	2	$V_{\text{EN}} = 5V$, All $V_A = 0V$ or 5V	-	-	100	-	-	1000	μA
Positive Standby Current	V_+	1	1	$V_{\text{EN}} = 0V$, All $V_A = 0V$ or 5V	-	-	100	-	-	1000	μA
Negative Standby Current	V_-	1	1	$V_{\text{EN}} = 0V$, All $V_A = 0V$ or 5V	-	-	100	-	-	1000	μA

NOTE:

- See "Enable Input Strobing Levels", in Application Section.

Switching Information

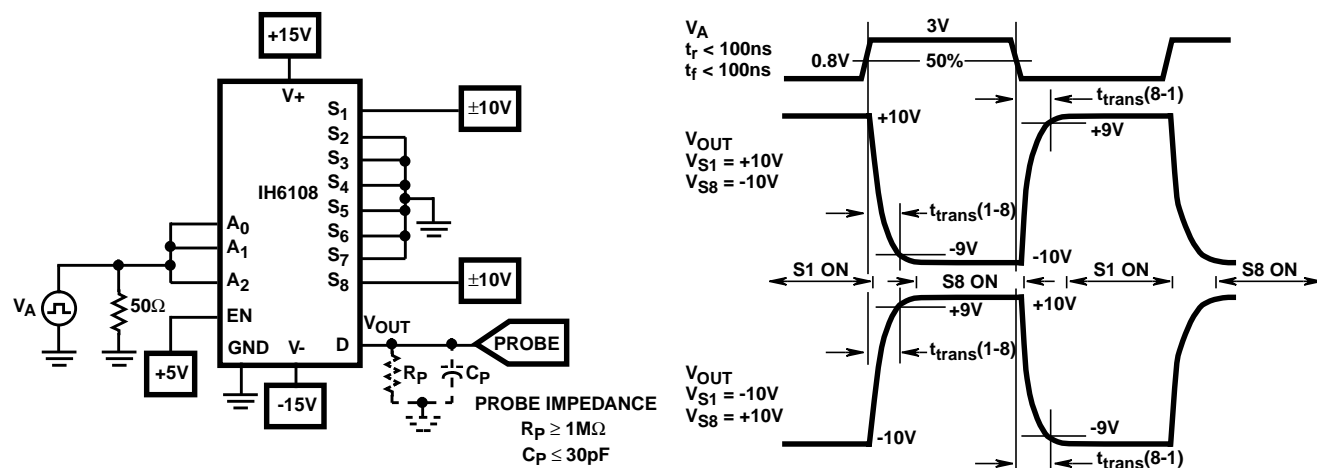

FIGURE 1. $t_{\text{TRANSITION}}$ SWITCHING TEST CIRCUIT AND WAVEFORMS

Switching Information (Continued)

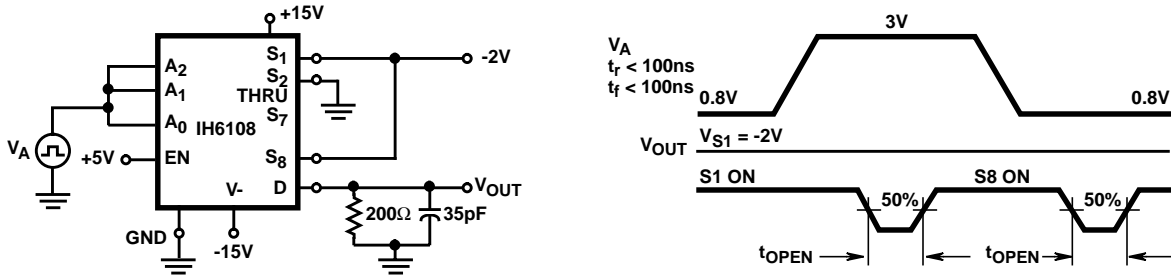

FIGURE 2. t_{OPEN} (BREAK-BEFORE-MAKE) SWITCHING TEST CIRCUIT AND WAVEFORMS

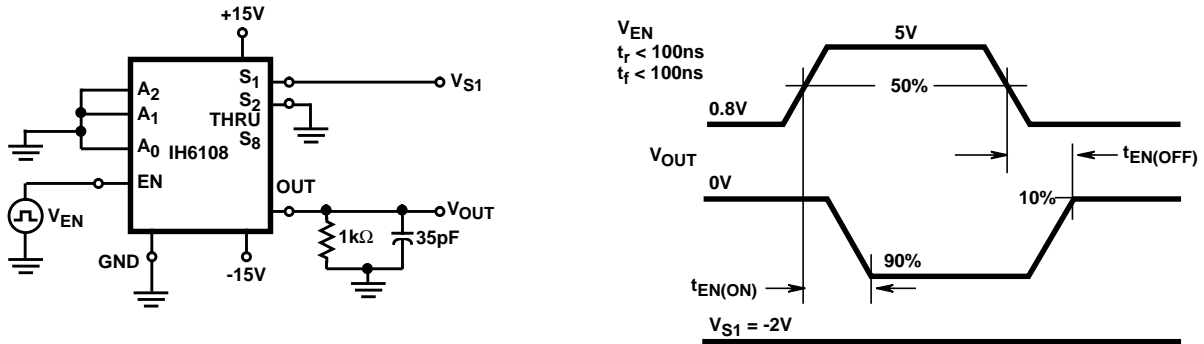

FIGURE 3. t_{ON} AND t_{OFF} SWITCHING TEST CIRCUIT AND WAVEFORMS

IH6108 Application Information

ENABLE Input Strobing Levels

The ENABLE input on the IH6108 requires a minimum of +4.5V to trigger to the “1” state and a maximum of +0.8V to trigger to the “0” state. If the ENABLE input is being driven from TTL logic, a pull-up resistor of 1k to 3kΩ is required from the gate output to +5V supply. (See Figure 4.)

When the EN input is driven from CMOS logic, no pullup is necessary, see Figure 5.

The supply voltage of the CD4009 affects the switching speed of the IH6108; the same is true for TTL supply voltage levels. The following chart shows the effect, on t_{trans} for a supply varying from +4.5V to +5.5V.

CMOS OR TTL SUPPLY VOLTAGE	TYPICAL T_{TRANS} AT 25°C
+4.5V	400ns
+4.75V	300ns
+5.00V	250ns
+5.25V	200ns
+5.50V	175ns

The throughput rate can therefore be maximized by using a +5V to +5.5V supply for the ENABLE Strobe Logic.

The examples shown in Figures 4 and 5 deal with ENABLE strobing when expansion to more than eight channels is required. In these cases the EN terminal acts as a fourth address input. If eight channels or less are being multiplexed, the EN terminal can be directly connected to +5V logic supply to enable the IH6108 at all times.

Using the IH6108 with Supplies Other Than ±15V

The IH6108 can be used with power supplies ranging from ±6V to ±16V. The switch $r_{DS(ON)}$ will increase as the supply voltages decrease, however, the multiplexer error term (the product of leakage times $r_{DS(ON)}$) will remain approximately constant since leakage decreases as the supply voltages are reduced.

Caution must be taken to ensure that the enable (EN) voltage is at least 0.7V below V_+ at all times. If this is not done, the Address input strobing levels will not function properly. This may be achieved quite simply by connecting EN (pin 2) to V_+ (pin 13) via a silicon diode as shown in Figure 6. When using this type of configuration, a further requirement must be met: the strobe levels of A0 and A1 must be within 2.5V of the EN voltage in order to define a binary “1” state. For the case shown in Figure 6 the EN voltage is 11.3V which means that logic high at A0 and A1 is +8.8V (logic low continues to be 0.8V). In this configuration the IH6108 cannot be driven by TTL (+5V) or CMOS (+5V) logic. It can be driven by TTL open collector logic or CMOS logic with +12V supplies.

If the logic and the IH6108 have common supplies, the EN pin should again be connected to the supply through a silicon diode. In this case, tying EN to the logic supply directly will not work since it violates the 0.7V differential voltage required between V_+ and EN, (See Figure 7). A 1μF capacitor can be placed across the diode to minimize switching glitches.

IH6108

Switching Information

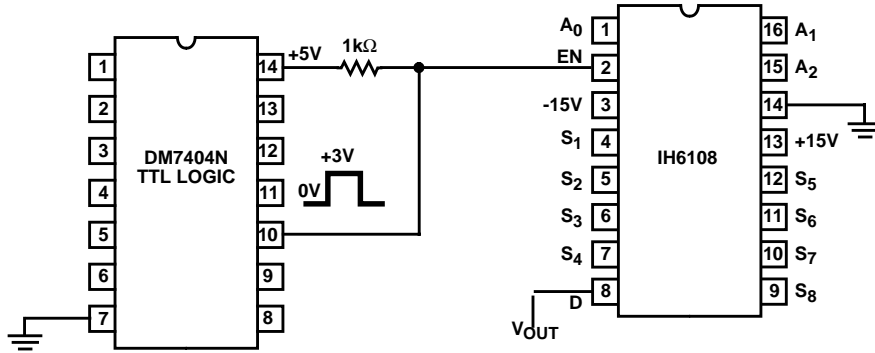

FIGURE 4. ENABLE INPUT STROBING FROM TTL LOGIC

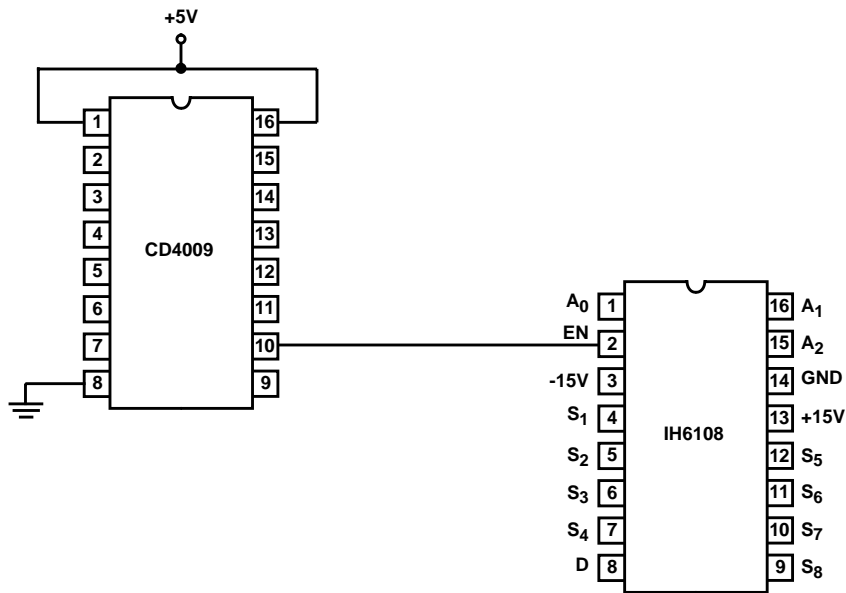

FIGURE 5. ENABLE INPUT DRIVEN FROM CMOS LOGIC

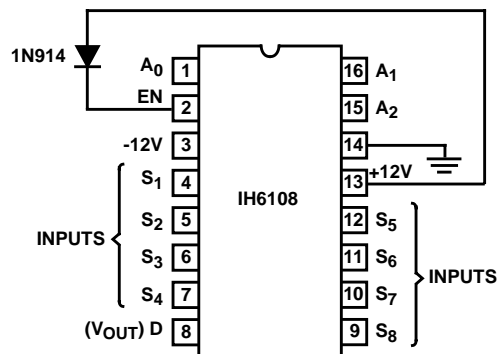

FIGURE 6. IH6108 CONNECTION DIAGRAM FOR LESS THAN $\pm 15V$ SUPPLY OPERATION

Switching Information (Continued)

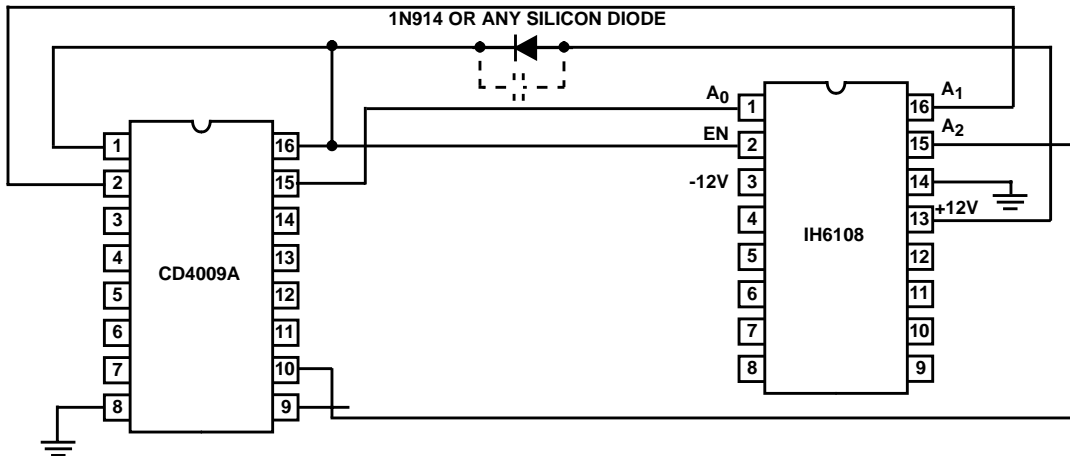

FIGURE 7. IH6108 CONNECTION DIAGRAM WITH ENABLE INPUT STROBING FOR LESS THAN ±15V SUPPLY OPERATION

Peak-to-Peak Signal Handling Capability

The IH6108 can handle input signals up to ±14V (actually -15V to +14.3V because of the input protection diode) when using the ±15V supplies.

The electrical specifications of the IH6108 are guaranteed for ±10V signals, but the specifications have very minor changes for ±14V signals. The notable changes are slightly lower $r_{DS(ON)}$ and slightly higher leakages.

TRUTH TABLE

A ₃	A ₂	A ₁	A ₀	ON SWITCH
0	0	0	0	S1
0	0	0	1	S2
0	0	1	0	S3
0	0	1	1	S4
0	1	0	0	S5
0	1	0	1	S6
0	1	1	0	S7
0	1	1	1	S8
1	0	0	0	S9
1	0	0	1	S10
1	0	1	0	S11
1	0	1	1	S12
1	1	0	0	S13
1	1	0	1	S14
1	1	1	0	S15
1	1	1	1	S16

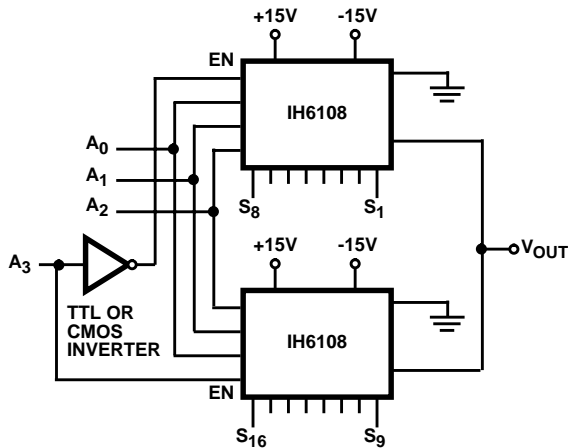

NOTE: TTL inverter must have pullup resistor to +5V to drive EN input.

FIGURE 8. 1 OF 16 CHANNEL MULTIPLEXER USING TWO IH6108s. OVERVOLTAGE PROTECTION IS MAINTAINED BETWEEN ALL CHANNELS, AS IS BREAK-BEFORE-MAKE SWITCHING.

IH6108

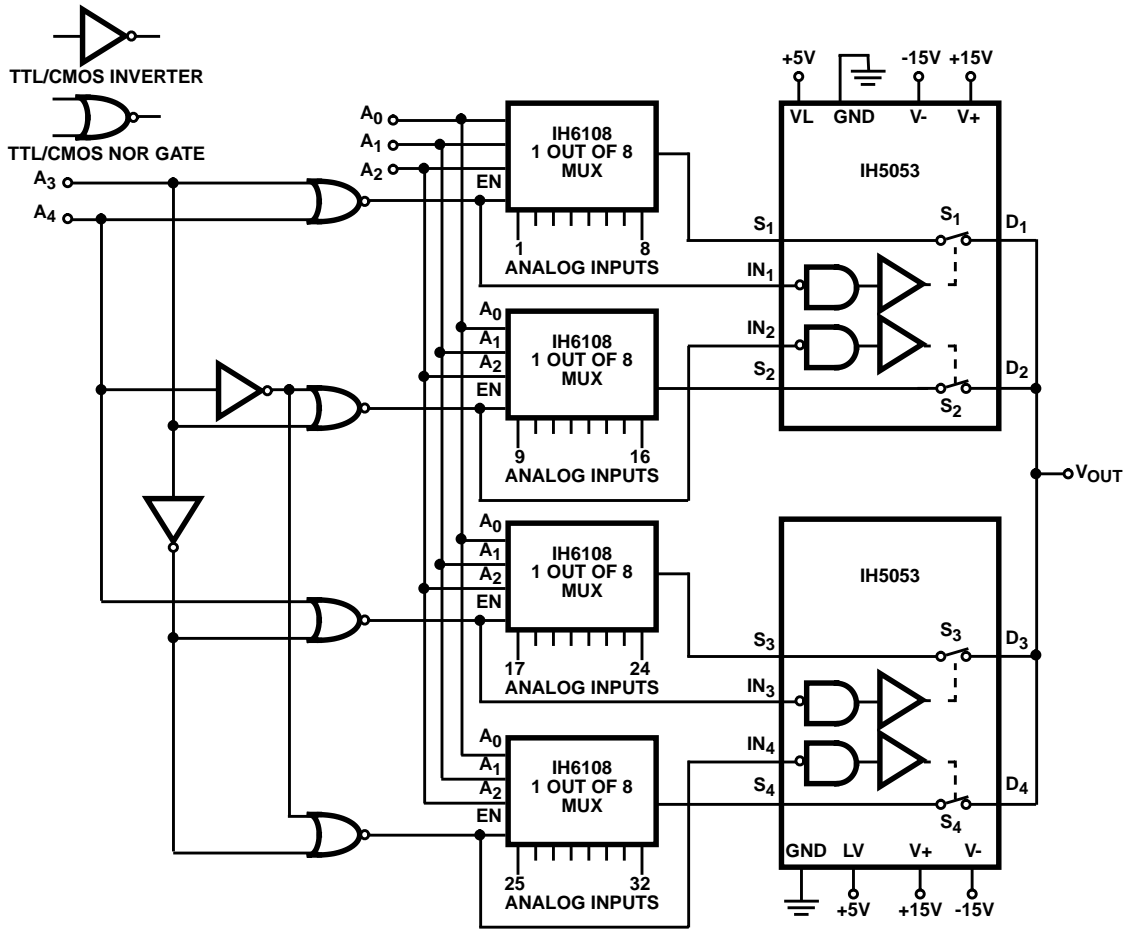

TRUTH TABLE

A ₄	A ₃	A ₂	A ₁	A ₀	ON SWITCH
0	0	0	0	0	S1
0	0	0	0	1	S2
0	0	0	1	0	S3
0	0	0	1	1	S4
0	0	1	0	0	S5
0	0	1	0	1	S6
0	0	1	1	0	S7
0	0	1	1	1	S8
0	1	0	0	0	S9
0	1	0	0	1	S10
0	1	0	1	0	S11
0	1	0	1	1	S12
0	1	1	0	0	S13
0	1	1	0	1	S14
0	1	1	1	0	S15
0	1	1	1	1	S16

TRUTH TABLE

A ₄	A ₃	A ₂	A ₁	A ₀	ON SWITCH
1	0	0	0	0	S17
1	0	0	0	1	S18
1	0	0	1	0	S19
1	0	0	1	1	S20
1	0	1	0	0	S21
1	0	1	0	1	S22
1	0	1	1	0	S23
1	0	1	1	1	S24
1	1	0	0	0	S25
1	1	0	0	1	S26
1	1	0	1	0	S27
1	1	0	1	1	S28
1	1	1	0	0	S29
1	1	1	0	1	S30
1	1	1	1	0	S31
1	1	1	1	1	S32

NOTE: TTL inverter must have pullup resistor to +5V to drive EN input.

FIGURE 9. 1 OF 32 CHANNEL MULTIPLEXER USING FOUR IH6108s, AND TWO IH5053s AS A SUBMULTIPLEXER

Schematic Diagram

- 1) A_0' OR $\overline{A_0}$
- 2) A_1' OR $\overline{A_1}$
- 3) A_2' OR $\overline{A_2}$

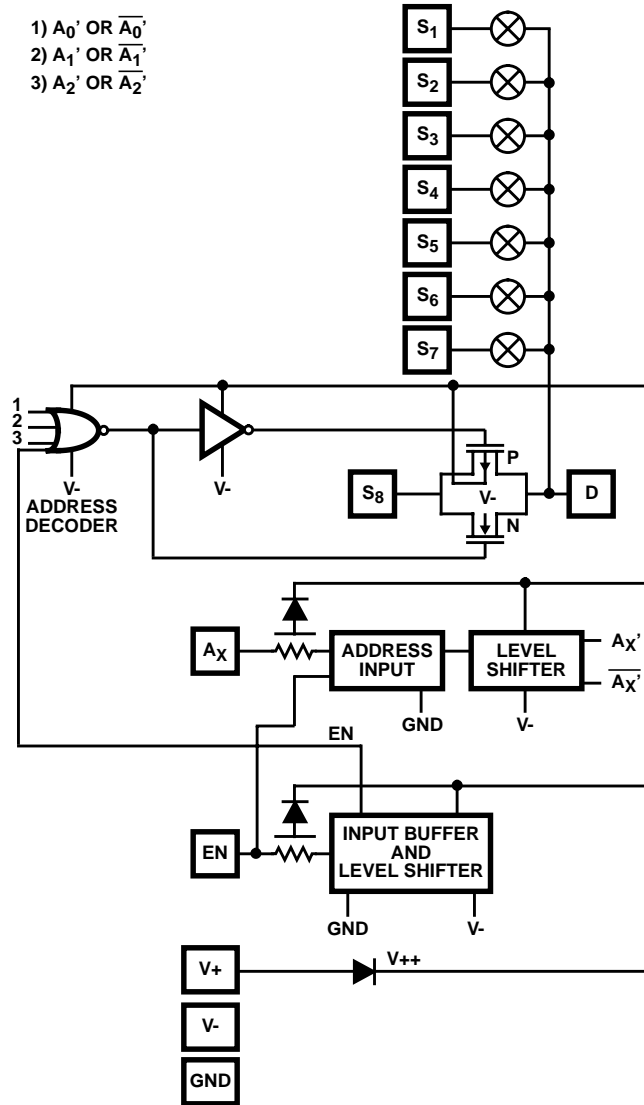

FIGURE 10. IH6108 SCHEMATIC DIAGRAM

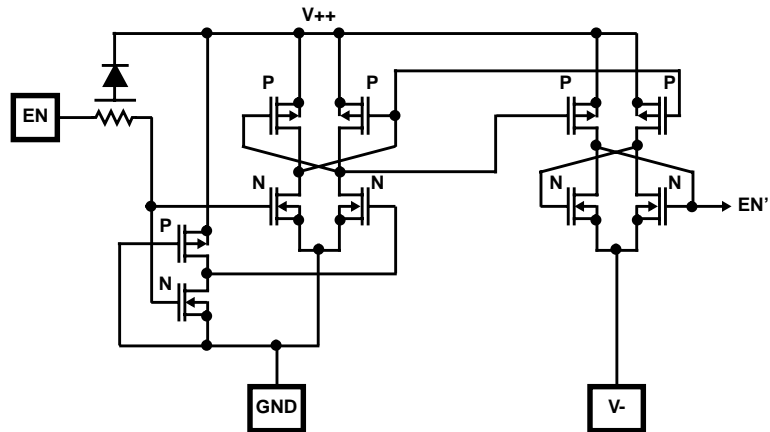

FIGURE 11. ENABLE INPUT AND LEVEL SHIFTER

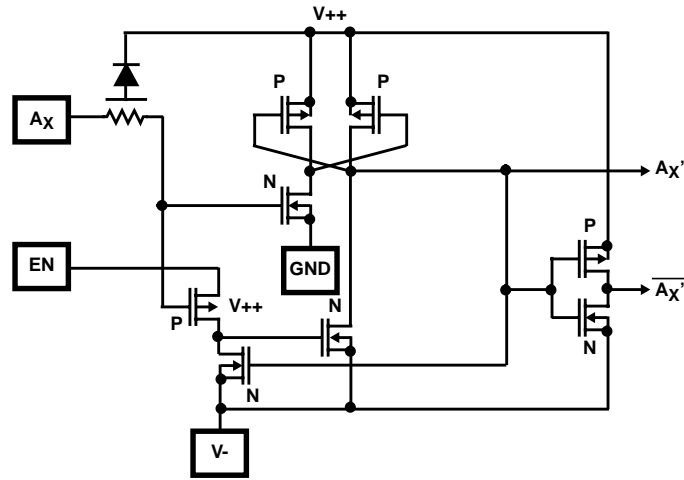

FIGURE 12. ADDRESS INPUT AND LEVEL SHIFTER

This datasheet has been downloaded from:

www.DatasheetCatalog.com

Datasheets for electronic components.



LittleDiode supplies new, hard to find or obsolete electronic components and semiconductors all over the world.

With over two million different components listed you are sure to find the part you need.

Feel free to visit us today at our online store:

LittleDiode.com

Looking forward to providing you with the best possible service.