

Optocoupler, Phototriac Output, Low Input Current

Features

- 400 and 600 V Blocking Voltage
- 5.0 mA Maximum Trigger Current
- Isolation Test Voltage, 5300 V_{RMS}, t = 1.0 sec.
- Isolation Materials per UL94
- Pin Compatible with Optocouplers
 - IL440-1 MOC 3051
 - IL440-2 MOC 3052
 - IL440-3 MOC3053
 - IL440-4 MOC 3021
 - IL440-5 MOC 3022
 - IL440-6 MOC 3023
- Lead-free component
- Component in accordance to RoHS 2002/95/EC and WEEE 2002/96/EC

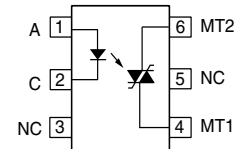
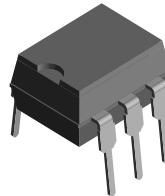

1179035



Agency Approvals

- UL1577, File No. E52744 System Code H or J, Double Protection
- CSA 93751
- DIN EN 60747-5-2 (VDE0884)
DIN EN 60747-5-5 pending
Available with Option 1
- BABT/ BSI IEC60950 IEC60065

Applications

High Current Triac Driver
Solid State Relay
Switch Small AC Loads

Description

The IL440 consists of a GaAs infrared emitter optically coupled to a silicon planar triac chip with a non-zero crossing network. The two semiconductors are assembled in a 6 pin dual-in-line plastic package. The output detector IL440-1, 2, 3 is capable of blocking up to 600 volts which permits control of off-line voltages up to 240 VAC. The IL440 can handle currents up to 100 mA RMS.

Order Information

Part	Remarks
IL440-1	15 mA I _{FT} , 600 V V _{DRM} , DIP-6
IL440-2	10 mA I _{FT} , 600 V V _{DRM} , DIP-6
IL440-3	5.0 mA I _{FT} , 600 V V _{DRM} , DIP-6
IL440-4	15 mA I _{FT} , 400 V V _{DRM} , DIP-6
IL440-5	10 mA I _{FT} , 400 V V _{DRM} , DIP-6
IL440-6	5.0 mA I _{FT} , 400 V V _{DRM} , DIP-6
IL440-1X009	15 mA I _{FT} , 600 V V _{DRM} , SMD-6 (option 9)
IL440-2X006	10 mA I _{FT} , 600 V V _{DRM} , DIP-6 400 mil (option 6)
IL440-3X007	5.0 mA I _{FT} , 600 V V _{DRM} , SMD-6 (option 7)
IL440-3X009	5.0 mA I _{FT} , 600 V V _{DRM} , SMD-6 (option 9)
IL440-4X007	15 mA I _{FT} , 400 V V _{DRM} , SMD-6 (option 7)
IL440-4X009	15 mA I _{FT} , 400 V V _{DRM} , SMD-6 (option 9)
IL440-5X006	10 mA I _{FT} , 400 V V _{DRM} , DIP-6 400 mil (option 6)
IL440-5X009	10 mA I _{FT} , 400 V V _{DRM} , SMD-6 (option 9)
IL440-6X006	5.0 mA I _{FT} , 400 V V _{DRM} , DIP-6 400 mil (option 6)
IL440-6X007	5.0 mA I _{FT} , 400 V V _{DRM} , SMD-6 (option 7)
IL440-6X009	5.0 mA I _{FT} , 400 V V _{DRM} , SMD-6 (option 9)

For additional information on the available options refer to Option Information.

Absolute Maximum Ratings

$T_{amb} = 25\text{ °C}$, unless otherwise specified

Stresses in excess of the absolute Maximum Ratings can cause permanent damage to the device. Functional operation of the device is not implied at these or any other conditions in excess of those given in the operational sections of this document. Exposure to absolute Maximum Rating for extended periods of the time can adversely affect reliability.

Input

Parameter	Test condition	Symbol	Value	Unit
Reverse voltage		V_R	5.0	V
Forward current		I_F	60	mA
Surge current	P.W. < 10 μ s	I_{FSM}	3.0	A
Power dissipation		P_{diss}	100	mW
Junction temperature		T_j	100	°C

Output

Parameter	Test condition	Part	Symbol	Value	Unit
Peak off-state voltage		IL440-1	V_{DRM}	600	V
		IL440-2	V_{DRM}	600	V
		IL440-3	V_{DRM}	600	V
		IL440-4	V_{DRM}	400	V
		IL440-5	V_{DRM}	400	V
		IL440-6	V_{DRM}	400	V
On-state RMS current			$I_{D(RMS)}$	100	mA
Peak surge current	$t_p \leq 10\text{ ms}$		I_{FSM}	1.2	A
Peak on-state current	$t_p/T = 0.01 \leq 100\ \mu$ s		I_{DRM}	2.0	A
Power dissipation			P_{diss}	300	mW
Junction temperature			T_j	125	°C

Coupler

Parameter	Test condition	Symbol	Value	Unit
Isolation voltage, 1.0 sec., per Standard Climate 23 °C/50 % RH, DIN 50014		V_{ISO}	5300	V_{RMS}
Creepage			≥ 7.0	mm
Clearance			≥ 7.0	mm
Isolation resistance	$V_{IO} = 500\text{ V}, T_{amb} = 25\text{ °C}$	R_{IO}	$\geq 10^{12}$	Ω
	$V_{IO} = 500\text{ V}, T_{amb} = 100\text{ °C}$	R_{IO}	$\geq 10^{11}$	Ω
Total power dissipation		P_{tot}	330	mW
Storage temperature range		T_{stg}	- 55 to + 125	°C
Ambient temperature		T_{amb}	- 40 to + 100	°C
Junction temperature		T_j	100	°C
Lead soldering temperature	2.0 mm from case, $t < 10\text{ s}$	T_{sld}	260	°C

Electrical Characteristics

$T_{amb} = 25\text{ }^{\circ}\text{C}$, unless otherwise specified

Minimum and maximum values are testing requirements. Typical values are characteristics of the device and are the result of engineering evaluation. Typical values are for information only and are not part of the testing requirements.

Input

Parameter	Test condition	Symbol	Min	Typ.	Max	Unit
Forward voltage	$I_F = 50\text{ mA}$	V_F		1.25		V
Reverse voltage	$I_R = 10\text{ }\mu\text{A}$	V_R	5.0			V
Junction capacitance	$V_R = 0\text{ V}$, $f = 1.0\text{ MHz}$	C_j		50		pF

Output

Off- state output terminal voltage (see Table 1.)

Parameter	Test condition	Symbol	Min	Typ.	Max	Unit
Peak on-state voltage	$I_{TM} = 100\text{ mA}$, $I_{FT} = 30\text{ mA}$	V_{TM}		1.5	3.0	V
Critical rate of rise of off-state voltage	$I_F = 0$, $V_S = 240\text{ V}_{RMS}$	dV_{cr}/dt		50		V/ μs
	$I_F = 30\text{ mA}$, $V_S = 60\text{ V}_{RMS}$	dV_{crq}/dt	0.13	0.25		V/ μs

I_{FT} and Blocking Voltage Selection¹⁾

Bin number	BV (Volts) Max @ $I_{DRM} = 500\text{ nA}$	I_{FT} Max @ $V_T = 6\text{ V}$, $R_L = 150\text{ }\Omega$
IL440-1	600	15
IL440-2	600	10
IL440-3	600	5.0
IL440-4	400	15
IL440-5	400	10
IL440-6	400	5.0

¹⁾ Test voltage must be applied within dV/dt rating of $0.13\text{ V}/\mu\text{sec}$.

Coupler

Parameter	Test condition	Symbol	Min	Typ.	Max	Unit
Holding current	$I_F \geq 10\text{ mA}$, $V_S \geq 3.0\text{ V}$	I_H		1.0		mA

Maximum Safety Ratings

(according to DIN EN 60747-5-2(VDE0884)/ DIN EN 60747-5-5 pending) see figure 1

This optocoupler is suitable for safe electrical isolation only within the safety ratings.

Compliance with the safety ratings shall be ensured by means of suitable protective circuits.

Input

The device is used for protective separation against electrical shock within the maximum safety ratings. This must be ensured by protective circuits in the applications.

Parameter	Test condition	Symbol	Min	Typ.	Max	Unit
Forward voltage		$I_{S, INPUT}$			130	mA

Output

Parameter	Test condition	Symbol	Min	Typ.	Max	Unit
Power dissipation		$P_{S, OUTPUT}$			300	mW

Package Dimensions in Inches (mm)

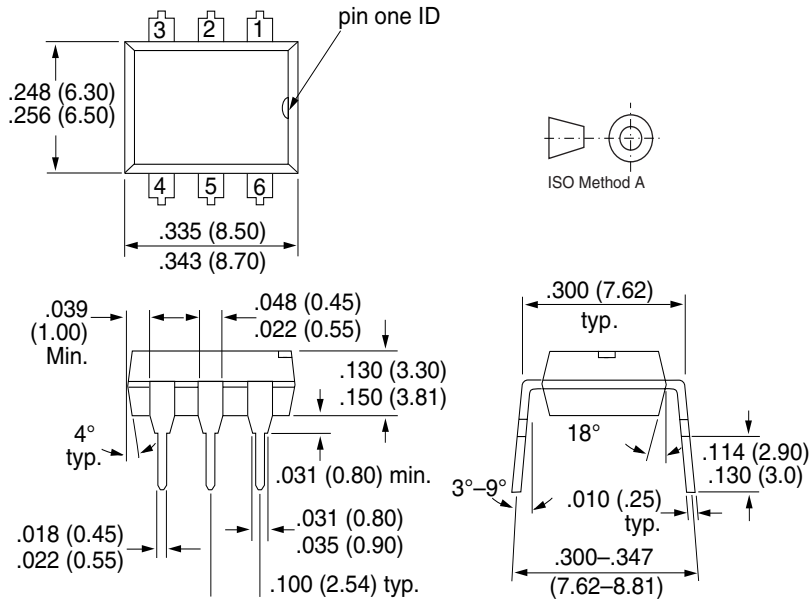

i178004

Option 6

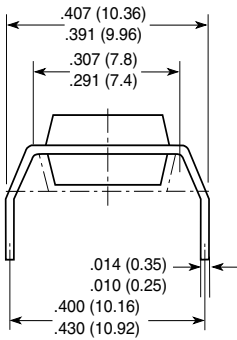

Option 7

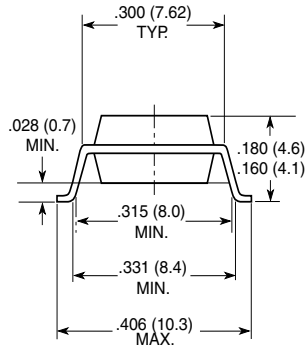

Option 9

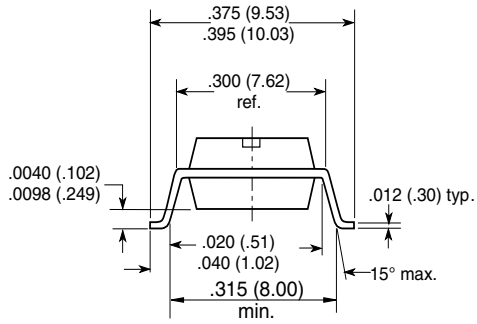

18450

Ozone Depleting Substances Policy Statement

It is the policy of Vishay Semiconductor GmbH to

1. Meet all present and future national and international statutory requirements.
2. Regularly and continuously improve the performance of our products, processes, distribution and operating systems with respect to their impact on the health and safety of our employees and the public, as well as their impact on the environment.

It is particular concern to control or eliminate releases of those substances into the atmosphere which are known as ozone depleting substances (ODSs).

The Montreal Protocol (1987) and its London Amendments (1990) intend to severely restrict the use of ODSs and forbid their use within the next ten years. Various national and international initiatives are pressing for an earlier ban on these substances.

Vishay Semiconductor GmbH has been able to use its policy of continuous improvements to eliminate the use of ODSs listed in the following documents.

1. Annex A, B and list of transitional substances of the Montreal Protocol and the London Amendments respectively
2. Class I and II ozone depleting substances in the Clean Air Act Amendments of 1990 by the Environmental Protection Agency (EPA) in the USA
3. Council Decision 88/540/EEC and 91/690/EEC Annex A, B and C (transitional substances) respectively.

Vishay Semiconductor GmbH can certify that our semiconductors are not manufactured with ozone depleting substances and do not contain such substances.

We reserve the right to make changes to improve technical design and may do so without further notice.

Parameters can vary in different applications. All operating parameters must be validated for each customer application by the customer. Should the buyer use Vishay Semiconductors products for any unintended or unauthorized application, the buyer shall indemnify Vishay Semiconductors against all claims, costs, damages, and expenses, arising out of, directly or indirectly, any claim of personal damage, injury or death associated with such unintended or unauthorized use.

Vishay Semiconductor GmbH, P.O.B. 3535, D-74025 Heilbronn, Germany
Telephone: 49 (0)7131 67 2831, Fax number: 49 (0)7131 67 2423



LittleDiode supplies new, hard to find or obsolete electronic components and semiconductors all over the world.

With over two million different components listed you are sure to find the part you need.

Feel free to visit us today at our online store:

LittleDiode.com

Looking forward to providing you with the best possible service.