

## POWER MANAGEMENT

### μP Power Supply Supervisor with Battery Backup Switch

The IMP690A/IMP692A/IMP802L/IMP802M/IMP805L simplify power supply monitoring and control in microprocessor systems. Each circuit implements four functions: Reset control, watchdog monitoring, battery-backup switching and power-failure monitoring. In addition to microprocessor reset under powerup and power-down conditions, these devices provide battery-backup switching to maintain control in power-loss and brown-out situations. Additional monitoring capabilities can provide an early warning of unregulated power-supply loss before the voltage regulator drops out. The important features of these four functions are:

- a) 1.6 second watchdog timer to keep microprocessor responsive
- b) 4.40V or 4.65V V<sub>CC</sub> threshold for microprocessor reset at power-up and power-down
- c) SPDT (single-pole, double-throw) PMOS switch connects backup power to RAM if V<sub>CC</sub> fails
- d) 1.25V threshold detector for power loss or general purpose voltage monitoring

While these features are pin-compatible with the industry standard power-supply supervisors offered by Maxim, the IMP devices are superior replacements and can reduce power requirements by 70 percent when compared to Maxim MAX690/MAX692A/MAX802L/MAX802M/MAX805L devices. Short-circuit and thermal protection have also been added.

The IMP690A/IMP802L/IMP805L generate a reset pulse when the supply voltage drops below 4.65V, and the IMP692A/IMP802M generate a reset below 4.40V. The IMP802L/IMP802M have power-fail accuracy to ±2%. The IMP805L is the same as the IMP690A except that RESET is provided instead of RESET.

### Block Diagrams

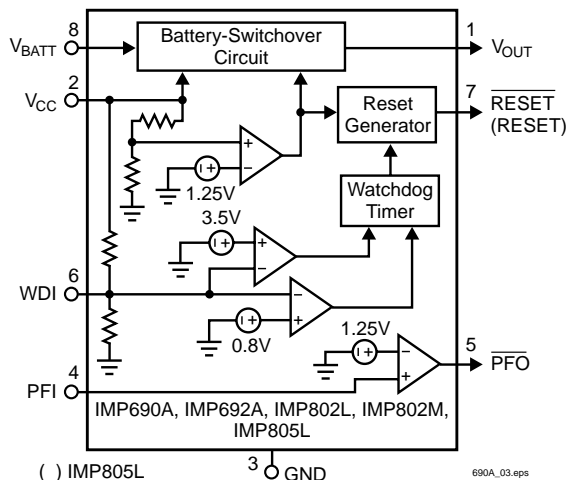

### Key Features

- ◆ Design improvement over Maxim MAX690A/692A/802L/802M/805L
  - 70% lower current than Maxim: 100μA maximum
  - RESET Operation to 1.1V
- ◆ Two precision supply-voltage monitor options
  - 4.65V (IMP690A/802L/805L)
  - 4.40V (IMP692A/802M)
- ◆ Battery-backup power switch on-chip
- ◆ Watchdog timer: 1.6 second timeout
- ◆ Power failure/low battery detection
- ◆ Short-circuit protection and thermal limiting
- ◆ Small 8-pin SO package
- ◆ No external components
- ◆ Specified over full temperature range

### Applications

- ◆ Embedded control systems
- ◆ Battery-operated systems
- ◆ Intelligent instruments
- ◆ Wireless communication systems
- ◆ PDAs and handheld equipment
- ◆ μP/μC power supply monitoring

### Typical Application

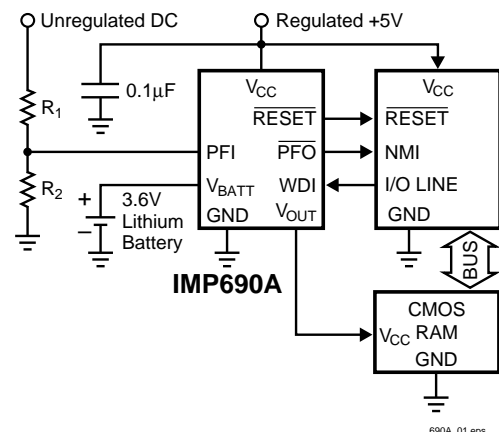

## Pin Configuration

### Plastic/CerDip/SO

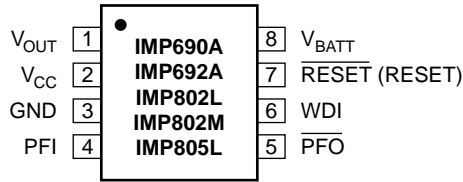

( ) IMP805L

690A\_02.eps

## Ordering Information

Part Number	Reset Threshold (V)	Temperature Range	Pins-Package
<b>IMP690A</b>			
IMP690ACPA	4.5 to 4.75	0°C to +70°C	8-Plastic DIP
IMP690ACSA	4.5 to 4.75	0°C to +70°C	8-SO
IMP690AC/D	4.5 to 4.75	25°C	DICE
IMP690AEPA		-40°C to +85°C	8-Plastic DIP
IMP690AESA	4.5 to 4.75	-40°C to +85°C	8-SO
IMP690AMJA	4.5 to 4.75	Contact Factory	8-CerDIP
<b>IMP692A</b>			
IMP692ACPA	4.25 to 4.50	0°C to +70°C	8-Plastic DIP
IMP692ACSA	4.25 to 4.50	0°C to +70°C	8-SO
IMP692AC/D	4.25 to 4.50	25°C	DICE
IMP692AEPA	4.25 to 4.50	-40°C to +85°C	8-Plastic DIP
IMP692AESA	4.25 to 4.50	-40°C to +85°C	8-SO
IMP692AMJA	4.25 to 4.50	Contact Factory	8-CerDIP
<b>IMP802L</b>			
IMP802LCPA	4.5 to 4.75	0°C to +70°C	8-Plastic DIP
IMP802LCSA	4.5 to 4.75	0°C to +70°C	8-SO
IMP802LEPA	4.5 to 4.75	-40°C to +85°C	8-Plastic DIP
IMP802LESA	4.5 to 4.75	-40°C to +85°C	8-SO
<b>IMP802M</b>			
IMP802MCPA	4.25 to 4.50	0°C to +70°C	8-Plastic DIP
IMP802MCSA	4.25 to 4.50	0°C to +70°C	8-SO
IMP802MEPA	4.25 to 4.50	-40°C to +85°C	8-Plastic DIP
IMP802MESA	4.25 to 4.50	-40°C to +85°C	8-SO
<b>IMP805L</b>			
IMP805LCPA	4.5 to 4.75	0°C to +70°C	8-Plastic DIP
IMP805LCSA	4.5 to 4.75	0°C to +70°C	8-SO
IMP805LC/D	4.5 to 4.75	25°C	DICE
IMP805LEPA	4.5 to 4.75	-40°C to +85°C	8-Plastic DIP
IMP805LESA	4.5 to 4.75	-40°C to +85°C	8-SO
IMP805LMJA	4.5 to 4.75	Contact Factory	8-CerDIP

## Pin Description

Pin Number		Name	Function
IMP690A/IMP692A IMP802L/IMP802M	IMP805L		
1	1	V <sub>OUT</sub>	Voltage supply for RAM. When V <sub>CC</sub> is above the reset threshold, V <sub>OUT</sub> connects to V <sub>CC</sub> through a P-channel MOS device. If V <sub>CC</sub> falls below the reset threshold, this output will be connected to the backup supply at V <sub>BATT</sub> (or V <sub>CC</sub> , whichever is higher) through the MOS switch to provide continuous power to the CMOS RAM.
2	2	V <sub>CC</sub>	+5V power supply input
3	3	GND	Ground
4	4	PFI	Power failure monitor input. PFI is connected to the internal power fail comparator which is referenced to 1.25V. The power fail output (PFO) is active LOW but remains HIGH if PFI is above 1.25V. If this feature is unused, the PFI pin should be connected to GND or V <sub>OUT</sub> .
5	5	PFO	Power-fail output. PFO is active LOW whenever the PFI pin is less than 1.25V.
6	6	WDI	Watchdog input. The WDI input monitors microprocessor activity. An internal timer is reset with each transition of the WDI input. If WDI is held HIGH or LOW for longer than the watchdog timeout period, typically 1.6 seconds, RESET (or RESET) is asserted for the reset pulse width time, t <sub>RS</sub> , of 140ms, minimum.
7	—	RESET	Active-LOW reset output. When triggered by V <sub>CC</sub> falling below the reset threshold or by watchdog timer timeout, RESET (or RESET) pulses low for the reset pulse width, t <sub>RS</sub> , typically 200ms. It will remain low if V <sub>CC</sub> is below the reset threshold (4.65V in the IMP690A/IMP802L and 4.4V in the IMP692A/IMP802L) and remains low for 200ms after V <sub>CC</sub> rise above the reset threshold.
—	7	RESET	Active-HIGH reset output. The inverse of RESET.
8	8	V <sub>BATT</sub>	Auxiliary power or backup-battery input. V <sub>BATT</sub> should be connected to GND if the function is not used. This input has about 40mV of hysteresis to prevent rapid toggling between V <sub>CC</sub> and V <sub>BATT</sub> .

## Absolute Maximum Ratings

### Pin Terminal Voltage with Respect to Ground

V <sub>CC</sub>	−0.3V to 6.0V
V <sub>BATT</sub>	−0.3V to 6.0V
All Other Inputs*	−0.3V to (V <sub>CC</sub> + 0.3V)

Input Current at V<sub>CC</sub> . . . . . 200mA

Input Current at V<sub>BATT</sub> . . . . . 50mA

Input Current at GND . . . . . 20mA

### Output Current:

V <sub>OUT</sub>	Short circuit protected
All Other Inputs	20mA
Rate of Rise: V <sub>BATT</sub> and V <sub>CC</sub>	100V/μs

### Continuous Power Dissipation

Plastic DIP (derate 9mW/°C above 70°C) . . . 800mW

SO (derate 5.9mW/°C above 70°C) . . . . . 500mW

CerDIP (derate 8mW/°C above 70°C) . . . . . 650mW

Operating Temperature Range (C Devices) . . . 0°C to 70°C

Operating Temperature Range (E Devices) . . . −40°C to 85°C

Storage Temperature Range . . . . . −65°C to 160°C

Lead Temperature Soldering, (10 sec) . . . . . 300°C

\* The input voltage limits on PFI and WDI may be exceeded if the current is limited to less than 10mA

These are stress ratings only and functional operation is not implied. Exposure to absolute maximum ratings for prolonged time periods may affect device reliability.

## Electrical Characteristics

Unless otherwise noted  $V_{CC} = 4.75V$  to  $5.5V$  for the IMP690A/IMP802L/IMP805L and  $V_{CC} = 4.5V$  to  $5.5V$  for the IMP692A/IMP802M;  $V_{BATT} = 2.8V$ ; and  $T_A = T_{MIN}$  to  $T_{MAX}$ .

Parameter	Symbol	Conditions	Min	Typ	Max	Units
$V_{CC}$ , $V_{BATT}$ Voltage Range (Note 1)		IMP69_AC, IMP802_C	1.1		5.5	V
		IMP805LC	1.1		5.5	
		IMP69_AE, IMP802_E	1.1		5.5	
Supply Current Excluding $I_{OUT}$	$I_S$	IMP69_AC, IMP802_C		35	100	$\mu A$
		IMP69_AE, IMP802_E, IMP805LE		35	100	
$I_{SUPPLY}$ in Battery-Backup Mode (Excluding $I_{OUT}$ )		$V_{CC} = 0V$ , $V_{BATT} = 2.8V$	$T_A = 25^\circ C$ $T_A = T_{MIN}$ to $T_{MAX}$		1.0 5.0	$\mu A$
$V_{BATT}$ Standby Current (Note 2)		$5.5V > V_{CC} > V_{BATT} - 0.2V$	$T_A = 25^\circ C$ $T_A = T_{MIN}$ to $T_{MAX}$	-0.1 -1.0		0.02 0.02 $\mu A$
$V_{OUT}$ Output		$I_{OUT} = 5mA$	$V_{CC} - 0.025$	$V_{CC} - 0.010$		V
		$I_{OUT} = 50mA$	$V_{CC} - 0.25$	$V_{CC} - 0.10$		
$V_{OUT}$ in Battery-Backup Mode		$I_{OUT} = 250\mu A$ , $V_{CC} < V_{BATT} - 0.2V$	$V_{BATT} - 0.1$	$V_{BATT} - 0.001$		V
Battery Switch Threshold, $V_{CC}$ to $V_{BATT}$		$V_{CC} < V_{RT}$	Power-up Power-down		20 -20	
					40	
Battery Switchover Hysteresis				40		mV
Reset Threshold	$V_{RT}$	IMP690A/802L/805L	4.50	4.65	4.75	V
		IMP692A, IMP802M	4.25	4.40	4.50	
		IMP802L, $T_A = 25^\circ C$ , $V_{CC}$ falling	4.55		4.70	
		IMP802M, $T_A = 25^\circ C$ , $V_{CC}$ falling	4.30		4.45	
Reset Threshold Hysteresis				40		mV
Reset Pulse Width	$t_{RS}$		140	200	280	ms
Reset Output Voltage		$I_{SOURCE} = 800\mu A$	$V_{CC} - 1.5$		0.4 0.3 0.3	V
		$I_{SINK} = 3.2mA$				
		IMP69_AC, IMP802_C, $V_{CC} = 1.0V$ , $I_{SINK} = 50\mu A$				
		IMP69_AE, IMP802_E, $V_{CC} = 1.2V$ , $I_{SINK} = 100\mu A$	0.8 0.9			
		IMP805LC, $I_{SOURCE} = 4\mu A$ , $V_{CC} = 1.1V$				
		IMP805LE, $I_{SOURCE} = 4\mu A$ , $V_{CC} = 1.2V$	$V_{CC} - 1.5$			
		IMP805L, $I_{SOURCE} = 800\mu A$				
IMP805L, $I_{SINK} = 3.2mA$	0.4					
Watchdog Timeout	$t_{WD}$		1.00	1.60	2.25	sec
WDI Pulse Width	$t_{WP}$	$V_{IL} = 0.4V$ , $V_{IH} = 0.8V_{CC}$	50			ns
WDI Input Current		WDI = $V_{CC}$		50	150	$\mu A$
		WDI = 0V	-150	-50		
WDI Input Threshold (Note 3)		$V_{CC} = 5V$ , Logic LOW			0.8	V
		$V_{CC} = 5V$ , Logic HIGH	3.5			
PFI Input Threshold		IMP69_A, IMP805L, $V_{CC} = 5V$	1.20	1.25	1.30	V
		IMP802_C/E, $V_{CC} = 5V$	1.225	1.250	1.275	
PFI Input Current			-25	0.01	25	nA
PFO Output Voltage		$I_{SOURCE} = 800\mu A$	$V_{CC} - 1.5$		0.4	V
		$I_{SINK} = 3.2mA$				

Notes: 1. If  $V_{CC}$  or  $V_{BATT}$  is 0V, the other must be greater than 2.0V.

2. Battery charging-current is "-". Battery discharge-current is "+".

3. WDI is guaranteed to be in an intermediate level state if WDI is floating and  $V_{CC}$  is within the operating voltage range. WDI input impedance is  $50k\Omega$ . WDI is biased to  $0.3V_{CC}$ .

## Application Information

### Reset Output

It is important to initialize a microprocessor to a known state in response to specific events that could create code execution errors and “lock-up”. The reset output of these supervisory circuits send a reset pulse to the microprocessor in response to power-up, power-down/power-loss or a watchdog time-out. The reset pulse width,  $t_{RS}$ , is typically around 200ms and is LOW for the IMP690A, IMP692A, IMP802 and HIGH for the IMP805L.

Power-up reset occurs when a rising  $V_{CC}$  reaches the reset threshold,  $V_{RT}$ , forcing a reset condition in which the reset output is asserted in the appropriate logic state for the duration of  $t_{RS}$ . Figure 2 shows the reset pin timing.

Power-loss or “brown-out” reset occurs when  $V_{CC}$  dips below the reset threshold resulting in a reset assertion for the duration of  $t_{RS}$ . The reset signal remains asserted as long as  $V_{CC}$  is between  $V_{RT}$  and 1.1V, the lowest  $V_{CC}$  for which these devices can provide a guaranteed logic-low output. To ensure logic inputs connected to the IMP690A/692A/802 RESET pin are in a known state when  $V_{CC}$  is under 1.1V, a 100k $\Omega$  pull-down resistor at RESET is needed: the logic-high IMP805L will need a pull-up resistor to  $V_{CC}$ .

A Watchdog time-out reset occurs when a logic “1” or logic “0” is continuously applied to the WDI pin for more than 1.6 seconds. After the duration of the reset interval, the watchdog timer starts a new 1.6 second timing interval; the microprocessor must service the watchdog input by changing states or by floating the WDI pin before this interval is finished. If the WDI pin is held either HIGH or LOW, a reset pulse will be triggered every 1.8 seconds (the 1.6 second timing interval plus the reset pulse width  $t_{RS}$ ).

### Microprocessor Interface.

The IMP690 has logic-LOW RESET output while the IMP805 has an inverted logic-HIGH RESET output. Microprocessors with bi-directional reset pins (69HC11 for example) can pose a problem when the supervisory circuit and the microprocessor output pins attempt to go to opposite logic states. The problem can be resolved by placing a 4.7k $\Omega$  resistor between the RESET output and the microprocessor reset pin. This is shown in Figure 3. Since the series resistor limits drive capabilities, the reset signal to other devices should be buffered.

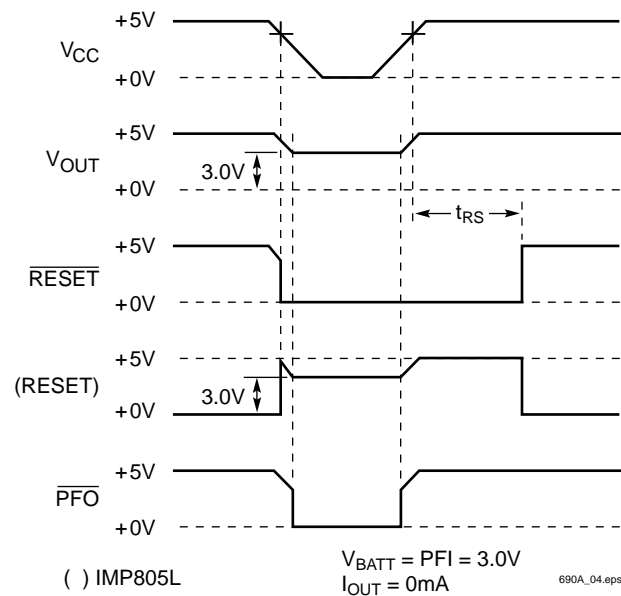

Figure 2. Timing Diagram

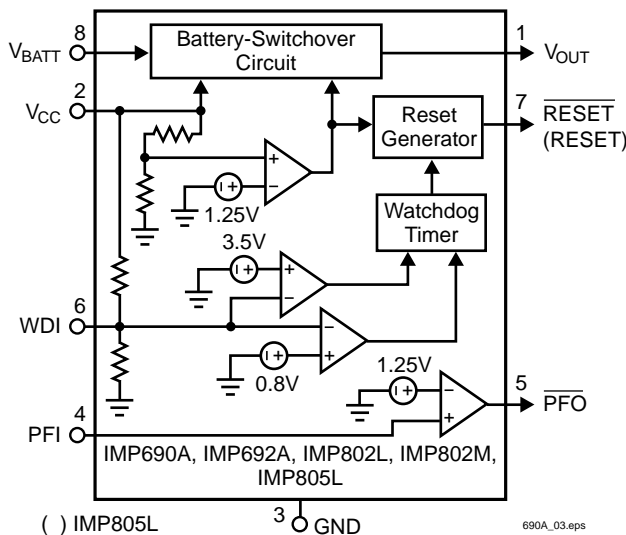

Figure 1. Block Diagram

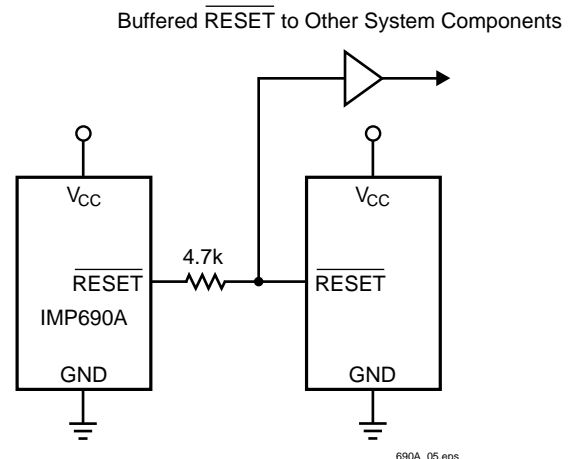

Figure 3. Interfacing with bi-directional microprocessor reset inputs

## Application Information

### Watchdog Input

As discussed in the Reset section, the Watchdog Input is used to monitor microprocessor activity. It can be used to insure that the microprocessor is in a continually responsive state by requiring that the WDI pin be toggled every second. If the WDI pin is not toggled within the 1.6 second window (minimum  $t_{WD} + t_{RS}$ ), a reset pulse will be asserted to return the microprocessor to the initial start-up state. Pulses as short as 50ns can be applied to the WDI pin. If this feature is not used, the WDI pin should be open-circuited or the logic placed into a high-impedance state to allow the pin to float.

### Backup-Battery Switchover

A power loss can be made less severe if the system RAM contents are preserved. This is achieved in the IMP690/692/802/805 by switching from the failed  $V_{CC}$  to an alternate power source connected at  $V_{BATT}$  when  $V_{CC}$  is less than the reset threshold voltage ( $V_{CC} < V_{RT}$ ), and  $V_{CC}$  is less than  $V_{BATT}$ . The  $V_{OUT}$  pin is normally connected to  $V_{CC}$  through a  $2\Omega$  PMOS switch but a brown-out or loss of  $V_{CC}$  will cause a switchover to  $V_{BATT}$  by means of a  $20\Omega$  PMOS switch. Although both conditions ( $V_{CC} < V_{RT}$  and  $V_{CC} < V_{BATT}$ ) must occur for the switchover to  $V_{BATT}$  to occur,  $V_{OUT}$  will be switched back to  $V_{CC}$  when  $V_{CC}$  exceeds  $V_{RT}$  irrespective of the voltage at  $V_{BATT}$ . It should be noted that an internal device diode (D1 in Figure 4) will be forward biased if  $V_{BATT}$  exceeds  $V_{CC}$  by more than a diode drop when  $V_{CC}$  is switched to  $V_{OUT}$ . Because of this it is recommended that  $V_{BATT}$  be no greater than  $V_{RT} + 0.6V$ .

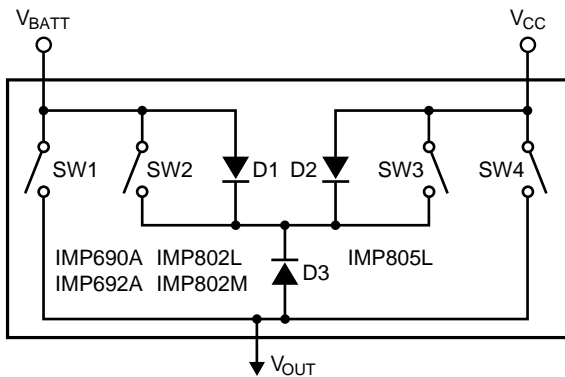

CONDITION	SW1/SW2	SW3/SW4
$V_{CC} >$ Reset Threshold	Open	Closed
$V_{CC} <$ Reset Threshold and $V_{CC} > V_{BATT}$	Open	Closed
$V_{CC} <$ Reset Threshold and $V_{CC} < V_{BATT}$	Closed	Open

IMP690A/IMP802L/IMP805L Reset Threshold = 4.65V  
 IMP692A/IMP802M Reset Threshold = 4.4V

690A\_06.eps

Figure 4. Internal device configuration of battery switchover function

Table 1. Pin Connections in Battery Backup Mode

Pin	Connection
$V_{OUT}$	Connected to $V_{BATT}$ through internal PMOS switch
$V_{BATT}$	Connected to $V_{OUT}$
PFI	Disabled
$\overline{PFO}$	Logic-LOW
$\overline{RESET}$	Logic LOW (except on IMP805 where it is HIGH)
WDI	Watchdog timer disabled

During the backup power mode, the internal circuitry of the supervisory circuit draws power from the battery supply. While  $V_{CC}$  is still alive, the comparator circuits remain alive and the current drawn by the device is typically  $35\mu A$ . When  $V_{CC}$  drops more than 1.1V below  $V_{BATT}$ , the internal switchover comparator, the PFI comparator and WDI comparator will shut off, reducing the quiescent current drawn by the IC to less than  $1\mu A$ .

### Backup Power Sources - Batteries

Battery voltage selection is important to insure that the battery does not discharge through the parasitic device diode D1 (see Figure 4) when  $V_{CC}$  is less than  $V_{BATT}$  and  $V_{CC} > V_{RT}$ .

Table 2. Maximum Battery Voltages

Part No.	MAXIMUM Battery Voltage
IMP690A	4.80
IMP802L	4.80
IMP805L	4.80
IMP692A	4.55
IMP802M	4.55

Although most batteries that meet the requirements of Table 2 are acceptable, lithium batteries are very effective backup source due to their high-energy density and very low self-discharge rates.

### Battery Replacement while Powered

Batteries can be replaced even when the device is in a powered state as long as  $V_{CC}$  remains above the reset threshold voltage  $V_{RT}$ . In the IMP devices, a floating  $V_{BATT}$  pin will not cause a power-supply switchover as can occur in some other supervisory circuits. If  $V_{BATT}$  is not used, the pin should be grounded.

## Application Information

### Backup Power Sources - SuperCap™

Capacitor storage, with very high values of capacitance, can be used as a back-up power source instead of batteries. SuperCap™ are capacitors with capacities in the fractional farad range. A 0.1 farad SuperCap™ would provide a useful backup power source. Like the battery supply, it is important that the capacitor voltage remain below the maximum voltages shown in *Table 2*. Although the circuit of *Figure 5* shows the most simple way to connect the SuperCap™, this circuit cannot insure that an overvoltage condition will not occur since the capacitor will ultimately charge up to  $V_{CC}$ . To insure that an overvoltage condition does not occur, the circuit of *Figure 6* is preferred. In this circuit configuration, the diode-resistor pair clamps the capacitor voltage at one diode-drop below  $V_{CC}$ .  $V_{CC}$  itself should be regulated within  $\pm 5\%$  of 5V for the IMP692A/802M or within  $\pm 10\%$  of 5V for the IMP690A/802L/805L to insure that the storage capacitor does not achieve an overvoltage state.

Note: SuperCap™ is a trademark of Baknor Industries

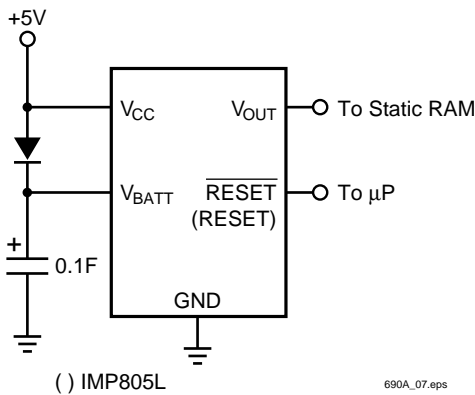

Figure 5. Capacitor as a backup power source

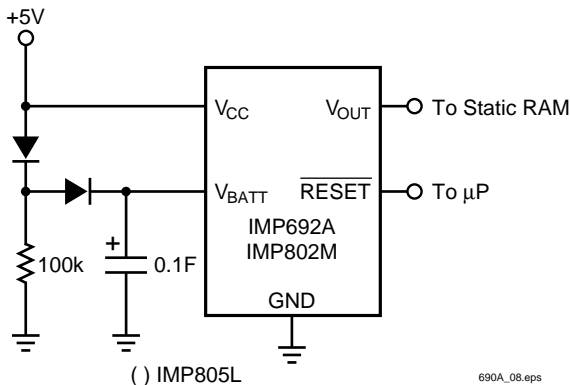

Figure 6. Capacitor as back-up Power Source - Voltage clamped to 0.5V below  $V_{CC}$

### Operation Without a Backup Power Source

When operating without a back-up power source, the  $V_{BATT}$  pin should be connected to GND and  $V_{OUT}$  should be connected to  $V_{CC}$  since power source switchover will not occur. Connecting  $V_{OUT}$  to  $V_{CC}$  eliminates the voltage drop due to the ON-resistance of the PMOS switch.

### Power-Fail Comparator

The Power Fail feature is an independent voltage monitoring function that can be used for any number of monitoring activities. The PFI function can provide an early sensing of power supply failure by sensing the voltage of the unregulated DC ahead of the regulated supply sensing seen by the backup-battery switchover circuitry.

The PFI pin is compared to a 1.25V internal reference. If the voltage at the PFI pin is less than this reference voltage, the  $\overline{PFO}$  pin goes low. By sensing the voltage of the raw DC power supply, the microprocessor system can prepare for imminent power-loss, especially if the battery backup supply is not enabled. The input voltage at the PFI pin results from a simple resistor voltage divider as shown in *Figure 7*.

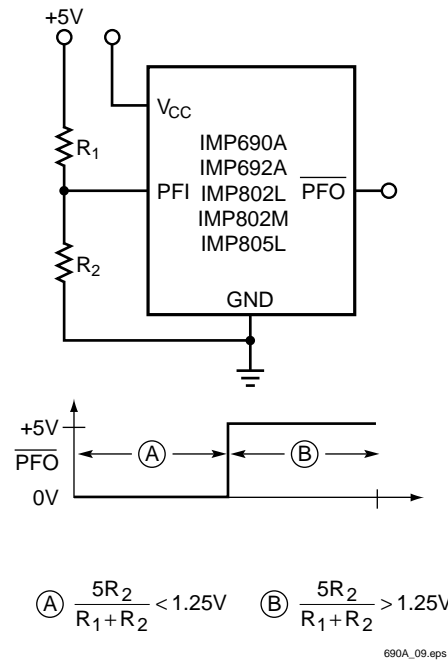

Figure 7. Simple Voltage divider sets PFI trip point

## Application Information

### Power Fail Hysteresis

A noise margin can be added to the simple monitoring circuit of Figure 7 by adding positive feedback from the  $\overline{\text{PFO}}$  pin. The circuit of Figure 8 adds this positive “latching” effect by means of an additional resistor R3 connected between  $\overline{\text{PFO}}$  and PFI which helps in pulling PFI in the direction of  $\overline{\text{PFO}}$  and eliminating an indecision at the trip point. Resistor R3 is normally about 10 times higher in resistance than R2 to keep the hysteresis band reasonable and should be larger than 10kΩ to avoid excessive loading on the  $\overline{\text{PFO}}$  pin. The calculations for the correct values of resistors to set the hysteresis thresholds are given in Figure 8. A capacitor can be added to offer additional noise rejection by low-pass filtering.

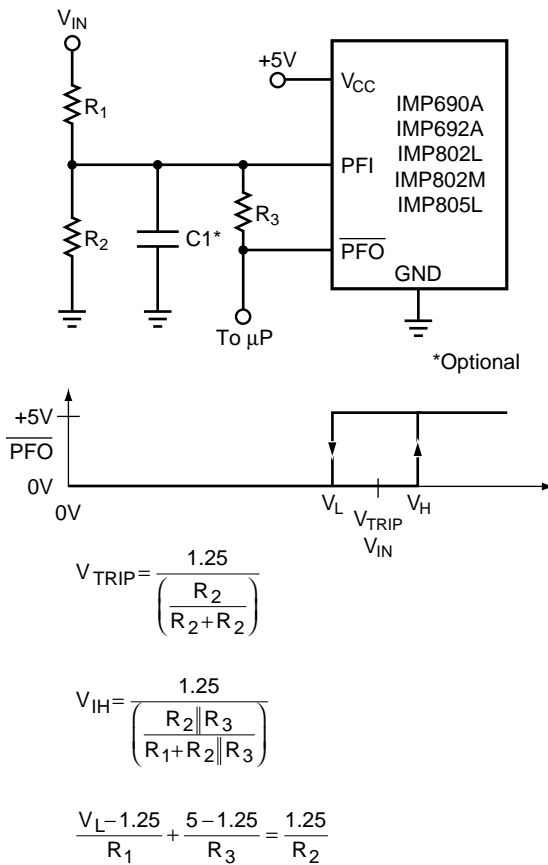

Figure 8. Hysteresis added to PFI pin

### Monitoring Capabilities of the Power-Fail Input

Although designed for power supply failure monitoring, the PFI pin can be used for monitoring any voltage condition that can be scaled by means of a resistive divider. An example is the negative power supply monitor configured in Figure 9. In this case a good negative supply will hold the PFI pin below 1.25V and the  $\overline{\text{PFO}}$  pin will be at a logic “0”. As the negative voltage declines, the voltage at the PFI pin will rise until it exceeds 1.25V and the  $\overline{\text{PFO}}$  pin will go to a logic “1”.

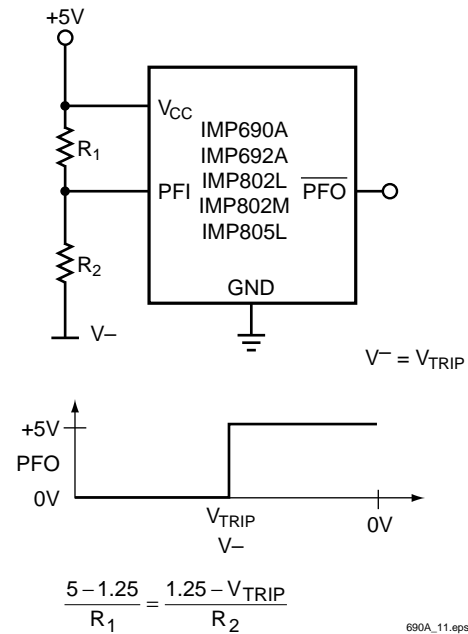
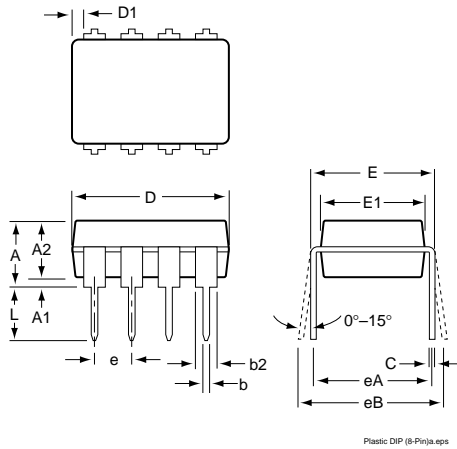

Figure 9. Using PFI to monitor negative supply voltage

## Package Dimensions

### Plastic DIP (8-Pin)



### CerDIP (8-Pin)

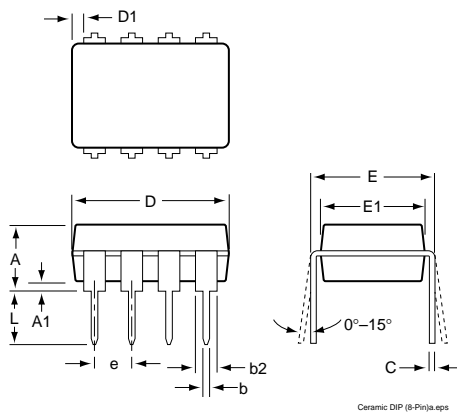

### SO (8-Pin)

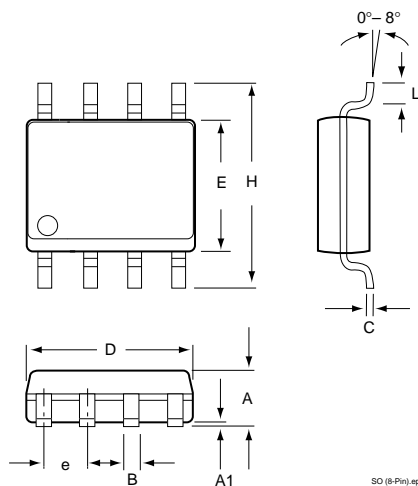

	Inches		Millimeters	
	Min	Max	Min	Max
<b>Plastic DIP (8-Pin)*</b>				
A	—	0.210	—	5.33
A1	0.015	—	0.38	—
A2	0.115	0.195	2.92	4.95
b	0.014	0.022	0.36	0.56
b2	0.045	0.070	1.14	1.78
b3	0.030	0.045	0.80	1.14
D	0.355	0.400	9.02	10.16
D1	0.005	—	0.13	—
E	0.300	0.325	7.62	8.26
E1	0.240	0.280	6.10	7.11
e	0.100	—	2.54	
eA	0.300	—	7.62	
eB	—	0.430	—	10.92
eC	—	0.060	—	—
L	0.115	0.150	2.92	3.81
<b>CerDIP (8-Pin)</b>				
A	—	0.200	—	5.08
A1	0.015	0.070	0.38	1.78
b	0.014	0.023	0.36	0.58
b2	0.038	0.065	0.97	1.65
C	0.008	0.015	0.20	0.38
D	—	0.405	—	10.29
D1	0.005	—	0.13	—
E	0.290	0.320	7.37	8.13
E1	0.220	0.310	5.59	7.87
e	0.100		2.54	
L	0.125	0.200	3.18	5.08
<b>SO (8-Pin)**</b>				
A	0.053	0.069	1.35	1.75
A1	0.004	0.010	0.10	0.25
B	0.013	0.020	0.33	0.51
C	0.007	0.010	0.19	0.25
e	0.050		1.27	
E	0.150	0.157	3.80	4.00
H	0.228	0.244	5.80	6.20
L	0.016	0.050	0.40	1.27
D	0.189	0.197	4.80	5.00

\* JEDEC Drawing MS-001BA

\*\* JEDEC Drawing MS-012AA



IMP, Inc.  
Corporate Headquarters  
2830 N. First Street  
San Jose, CA 95134-2071  
Tel: 408-432-9100  
Tel: 800-438-3722  
Fax: 408-434-0335  
Fax-on-Demand: 1-800-249-1614 (USA)  
Fax-on-Demand: 1-303-575-6156 (International)  
e-mail: [info@impinc.com](mailto:info@impinc.com)  
<http://www.impweb.com>

The IMP logo is a registered trademark of IMP, Inc.  
All other company and product names are trademarks of their respective owners.

© 1998 IMP, Inc.  
Printed in USA  
Preliminary  
Part No.: IMP 690A  
Document Number: IMP690A-2-9/98



LittleDiode supplies new, hard to find or obsolete electronic components and semiconductors all over the world.

With over two million different components listed you are sure to find the part you need.

Feel free to visit us today at our online store:

[LittleDiode.com](http://LittleDiode.com)

Looking forward to providing you with the best possible service.