

POWER MANAGEMENT

High-Voltage EL Lamp Driver

The IMP803 is an Electroluminescent (EL) lamp driver with the four EL lamp driving functions on-chip. These are the switch-mode power supply, its high-frequency oscillator, the high-voltage H-bridge lamp driver and its low-frequency oscillator. The IMP803 drives EL lamps of up to 30nF capacitance to high brightness; EL lamps with capacitances greater than 30nF can be driven, but will be lower in light output. The typical regulated output voltage that is applied to the EL lamp is 180V peak-to-peak. The circuit requires few external components, a single inductor, single diode, two capacitors and three resistors. Two of these resistors set the frequency for two internal oscillators.

The IMP803 operates over a 2.0V to 6.5V supply voltage range. A regulated, low-power source can supply the low quiescent current of the IMP803. The inductor may be driven from an independent, unregulated supply voltage in dual supply applications.

An internal circuit shuts down the switching regulator when the lamp drive voltage reaches 180V peak-to-peak. This conserves power and extends battery life.

The IMP803 is available in MicroSO and SO-8 packages and in die or wafer form.

Key Features

- ◆ Low Power: 420µA typical V_{DD} current
- ◆ Wide operating voltage range - from 2.0V to 6.5V
- ◆ 180V peak-to-peak typical AC output voltage
- ◆ Large output load capability - drive lamps with more than 30nF capacitance
- ◆ Adjustable output lamp frequency for control of lamp color, lamp life, and power consumption
- ◆ Adjustable converter frequency to minimize power consumption
- ◆ Device can be Enabled/Disabled
- ◆ Low quiescent current – 20nA (disabled)
- ◆ High-Voltage CMOS Process
- ◆ MicroSO package option

Applications

- ◆ GPS units/Pagers/Cellular phones
- ◆ PDAs/Handheld computers
- ◆ Safety illumination
- ◆ Portable instrumentation
- ◆ Battery-operated displays
- ◆ LCD modules
- ◆ Toys

Block Diagram

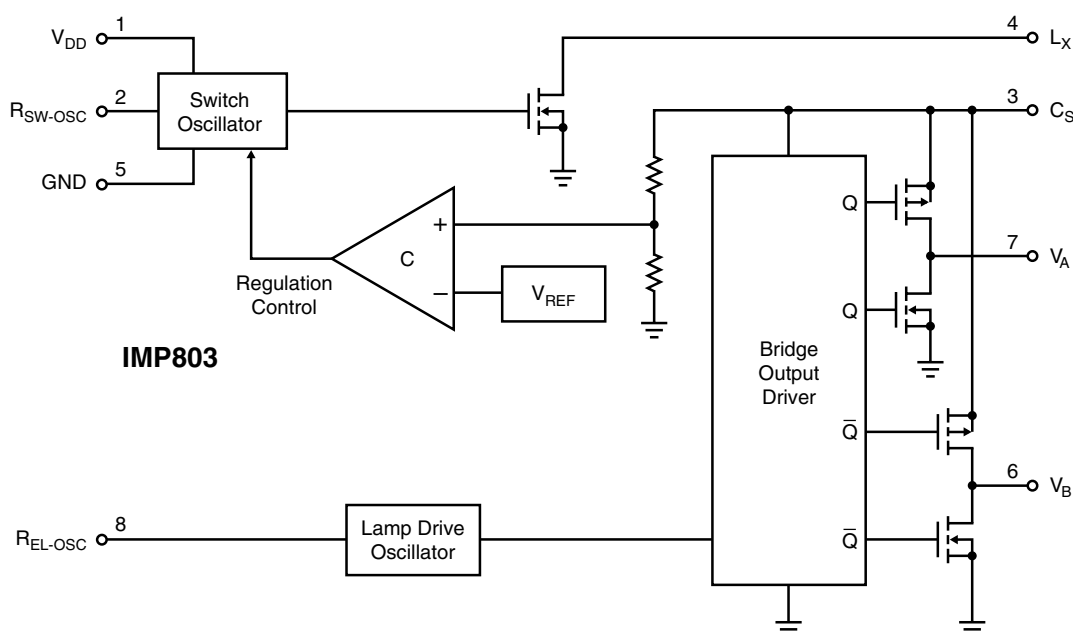

Pin Configuration

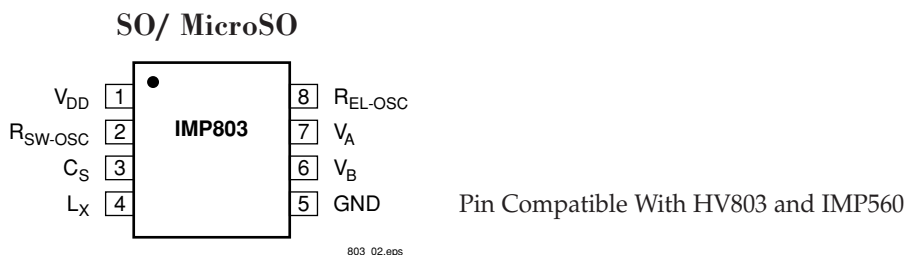

Ordering Information

Part Number	Input Voltage	Regulated Output Voltage	Temperature Range	Pins-Package
IMP803LG	2.0V to 6.5V	Yes	-40°C to +85°C	8-SO
IMP803IMA	2.0V to 6.5V	Yes	-40°C to +85°C	8-MicroSO
IMP803SX*	2.0V to 6.5V	Yes	25°C	Dice
IMP803/D1**	2.0V to 6.5V	Yes	25°C	Dice

* Disable pad not active

** Disable pad active

Add /T to ordering part number for Tape and Reel.

Absolute Maximum Ratings

V_{DD} , $V_{RSW-OSC}$ and $V_{REL-OSC}$	-0.5V to +7.0V
V_{CS} , L_X	-0.5V to +120V
Operating Temperature Range	-40°C to +85°C
Storage Temperature Range	-65°C to +150°C
Power Dissipation (SO)	400mW
Power Dissipation (MicroSO)	300mW
V_A , V_B	-0.5V to V_{CS} (pin 3)

Note: All voltages are referenced to GND.

These are stress ratings only and functional operation is not implied. Exposure to absolute maximum ratings for prolonged time periods may affect device reliability.

Electrical Characteristics

Unless otherwise noted, $V_{DD} = 3.0V$, $R_{SW} = 750k\Omega$, $R_{EL} = 2.0M\Omega$, and $T_A = 25^\circ C$.

Parameter	Symbol	Conditions	Min	Typ	Max	Units
ON-resistance of MOS Switch	$R_{DS(ON)}$	$I = 100mA$		3.5	8	Ω
Output Voltage Regulation	V_{CS}	$V_{DD} = 2.0$ to $6.5V$	80	90	100	V
Output Voltage Peak-to-peak (in regulation)	$V_A - V_B$	$V_{DD} = 2.0$ to $6.5V$	160	180	200	V
Quiescent V_{DD} Supply Current, Disabled	I_{DDQ}	$V_{RSW-OSC} < 100mV$		20	200	nA
Input Current at V_{DD} Pin	I_{DD}	$V_{DD} = 3.0V$, See Figure 1		420	700	μA
Input Current at V_{DD} Pin	I_{DD}	$V_{DD} = 5.0V$, See Figure 2		500	750	μA
Input Current: I_{DD} Plus Inductor Current	I_{IN}	$V_{DD} = 3.0V$, See Figure 1		20	31	mA
Output Voltage at V_{CS}	V_{CS}	$V_{DD} = 3.0V$, See Figure 1	60	74	100	V
V_{A-B} Output Drive Frequency	f_{EL}	$V_{DD} = 3.0V$, See Figure 1	300	370	430	Hz
Switching Frequency	f_{SW}	$V_{DD} = 3.0V$, See Figure 1	50	70	90	kHz
Switching Duty Cycle	D_{SW}	$V_{DD} = 3.0V$, See Figure 1		88		%

Typical Characteristics

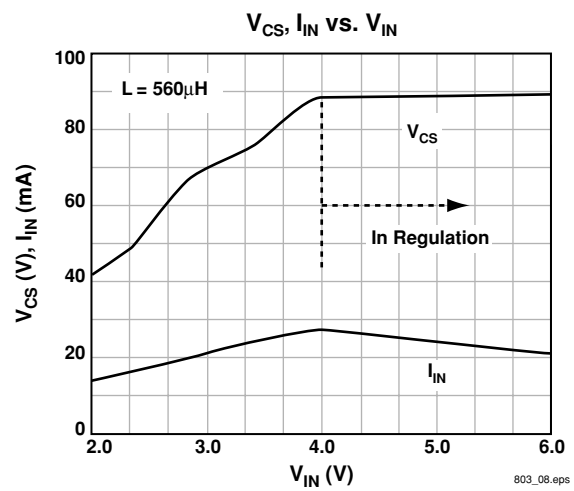
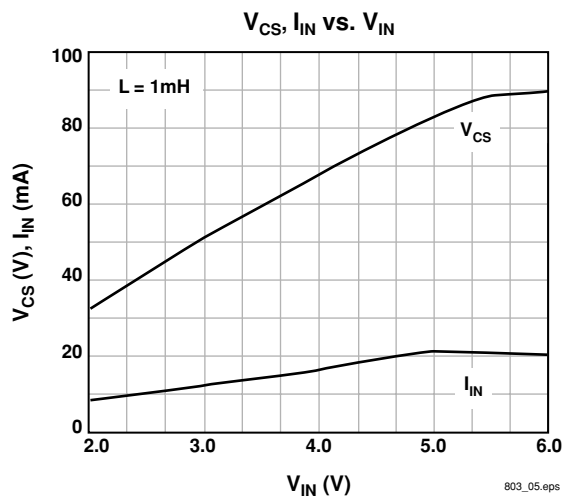
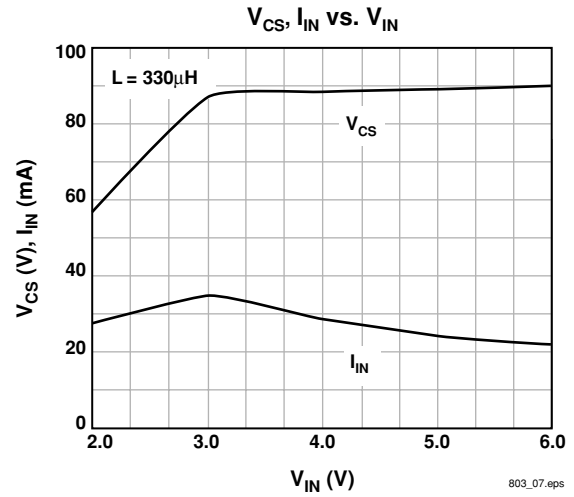
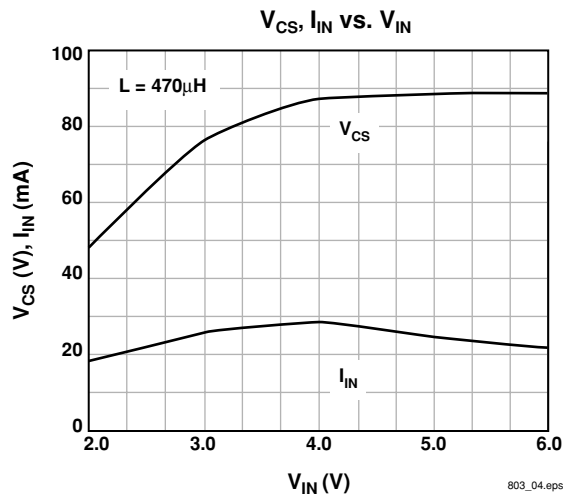
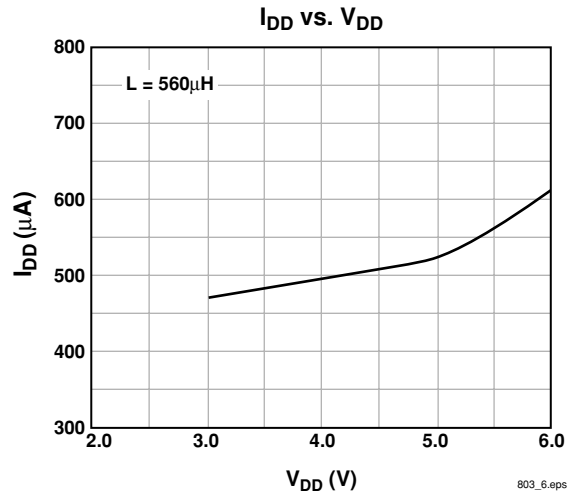
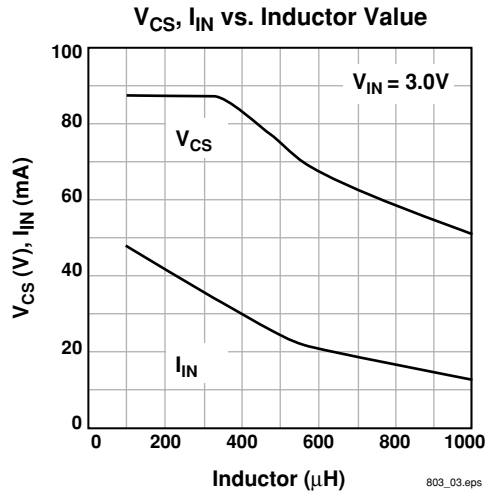

Pin Descriptions

Pin Number	Name	Function
1	V_{DD}	Positive voltage supply for the IMP803. Inductor L may be connected here or to a separate unregulated supply.
2	R_{SW-OSC}	Switch-mode resistor pin. Switching frequency is determined by an external resistor, R_{SW} .
3	C_S	Boost converter storage capacitor. The voltage across the EL lamp is equal to twice the voltage at C_S .
4	L_X	Connection to flyback inductance, L.
5	GND	Ground pin.
6	V_B	EL lamp drive. The lamp is connected in a high-voltage bridge circuit with V_B providing the complementary connection to V_A . The peak-to-peak AC voltage across the EL lamp is thus two times V_{CS} .
7	V_A	EL lamp drive. (See above)
8	R_{EL-OSC}	The EL lamp oscillator frequency setting pin. The oscillator frequency is controlled by external resistor R_{EL} .

External Components

External Component	Description and Selection Guide
Diode	Catch diode. A fast reverse recovery diode, with $BV > 100$, such as a 1N4148.
Capacitor C_S	This is the high voltage capacitor that stores the inductive energy transferred through the catch diode. A 100 volt capacitor between 10nF and 100nF is recommended.
Resistor R_{EL}	The EL lamp oscillator frequency setting resistor. This resistor, connected between the R_{EL-OSC} pin and V_{DD} , provides an oscillator frequency inversely proportional to R_{EL} ; as R_{EL} increases, the EL lamp frequency decreases along with the current drawn by the lamp. Lamp color is also determined by this frequency. A 2M Ω resistor between the R_{EL-OSC} pin and the V_{DD} supply results in a lamp frequency around 350Hz; a 1M Ω resistor will give ≈ 700 Hz.
Resistor R_{SW}	Switching Oscillator frequency setting resistor. The switching oscillator resistor is connected between the R_{SW-OSC} pin and the V_{DD} supply. The switching frequency is inversely proportional to the resistor value, dropping as the resistance increases.
Inductor L	The inductor provides the voltage boost needed by means of inductive “flyback”. The internal MOSFET switch alternately opens and closes the ground connection for the inductor at the L_X pin. When this internal switch opens, the inductor potential will forward-bias the catch diode and the current will pass through the storage capacitor C_S , charging it to a high voltage. Smaller inductors are preferred to prevent saturation. As the value of the inductor increases (and the series DC resistance of the inductor decreases), the switching frequency set by R_{SW} should be increased to prevent saturation. In general, smaller value inductors that can handle more current are more desirable when larger area EL lamps must be driven.
Lamp, R_{CL}	An external resistor (R_{CL}) in series with the lamp will protect the output drivers from high transient currents during lamp commutation.

High Voltages Present

The IMP803 generates high voltages and caution should be exercised.

Application Information

Test and Application Circuit, 3.0V

Figure 1 shows the IMP803 configured to drive a 3-square-inch EL lamp, represented as a 10nF capacitor. With a 3.0V input, the EL lamp will be driven to moderate brightness.

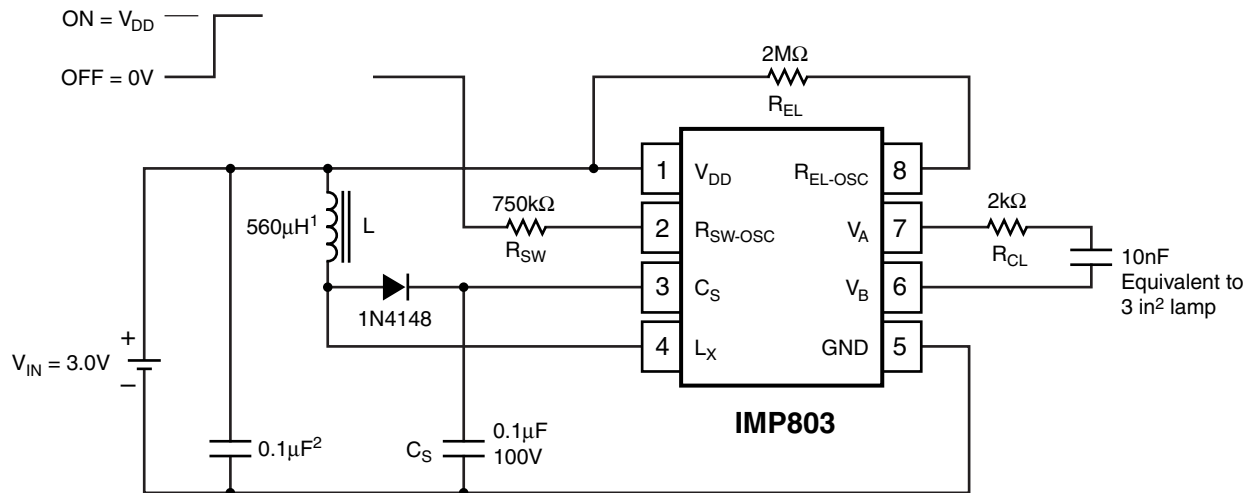

Note:

1. Murata part # LQH4N561K04 (DC resistance <math>< 14.5 \Omega</math>)
2. Larger values may be required depending upon supply impedance.

803_09.eps

Figure 1. 3.0V Application

Test and Application Circuit, 5.0V

Figure 2 shows a 5.0V input application driving a 6-square-inch EL lamp.

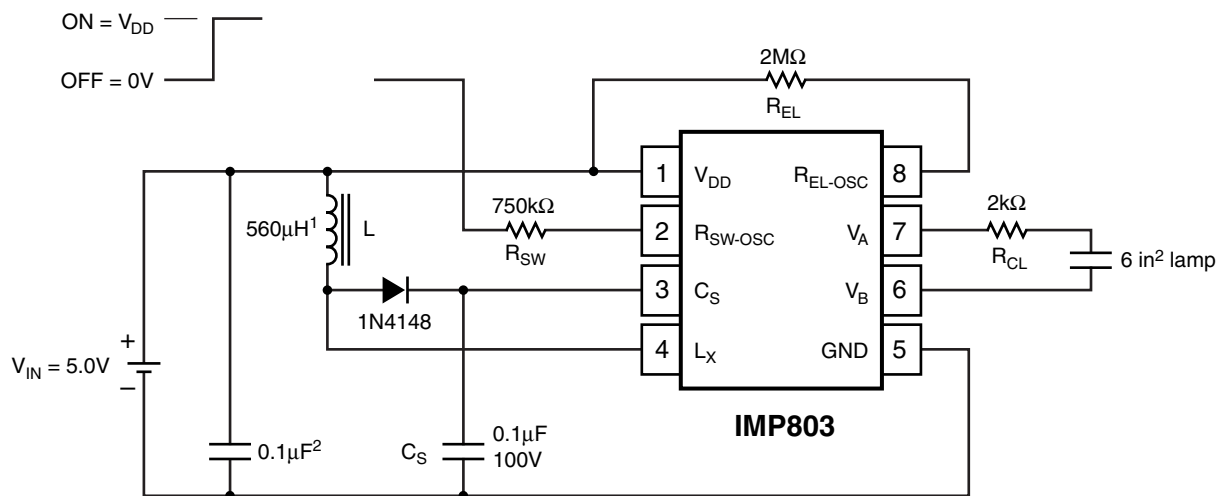

Note:

1. Murata part # LQH4N561K04 (DC resistance <math>< 14.5 \Omega</math>)
2. Larger values may be required depending upon supply impedance.

803_10.eps

Figure 2. 5.0V Application

Test and Application Circuit, 6.0V

At higher input voltage levels, the IMP803 will drive large EL lamps. Figure 3 shows a 6.0V circuit configuration that will drive a 10 square-inch lamp.

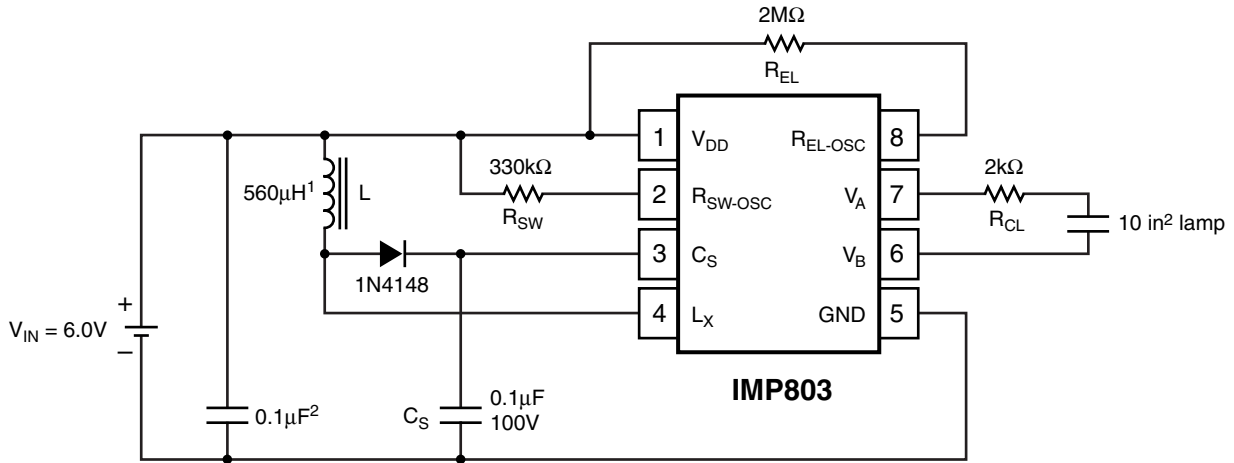

Note:
 1. Murata part # LQH4N561K04 (DC resistance <math><14.5 \Omega</math>)
 2. Larger values may be required depending upon supply impedance.

803_11.eps

Figure 3. 6.0V Application

Enable/Disable Operation

Figure 4 shows that the IMP803 can be enabled via a logic gate that connects R_{SW} to V_{DD} , and disabled by connecting it to ground.

Enable/Disable Table	
R_{SW} Connection	IMP803 State
V_{DD}	Enabled
GND	Disabled

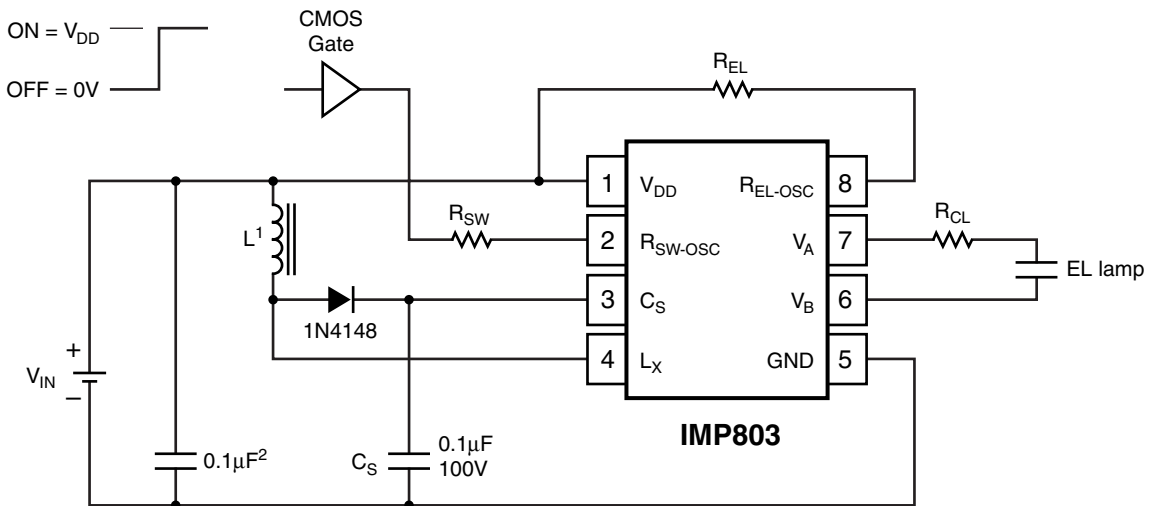

Note:
 1. Murata part # LQH4N561K04 (DC resistance <math><14.5 \Omega</math>)
 2. Larger values may be required depending upon supply impedance.

803_12.eps

Figure 4. Enable/Disable Operation

Dual Supply Operation with 1.5V Battery

The IMP803 can also operate from a single battery cell when a regulated voltage higher than 2.0V is also available. This dual supply configuration, shown in *Figure 5*, uses the regulated voltage to operate the IMP803 while the energy for the high-voltage boost circuit comes from the battery.

The circuit of *Figure 5* thus allows operation with batteries that are below the 2V minimum specification or above the 6.0V maximum operating voltage.

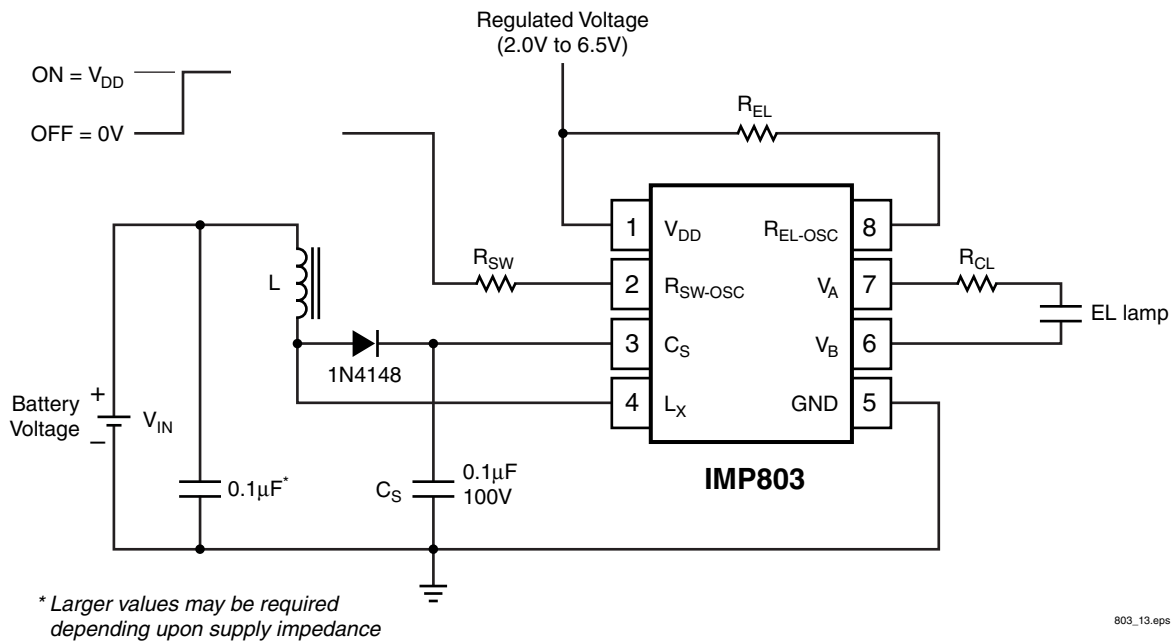

Figure 5. Dual Supply Operation

Switch Resistance

The IMP803 inductor switch resistance is typically below 3.5Ω, as shown in *Figure 6*.

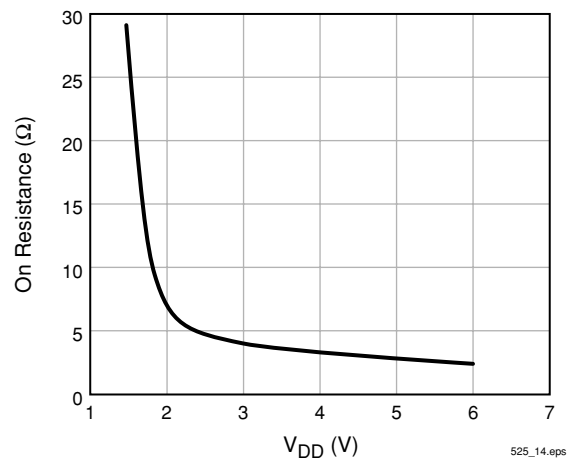
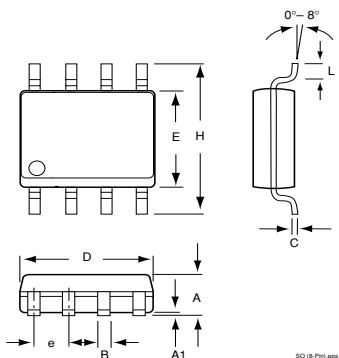

Figure 6. Boost Switch On Resistance

Package Dimensions

SO (8-Pin)



MicroSO (8-Pin)

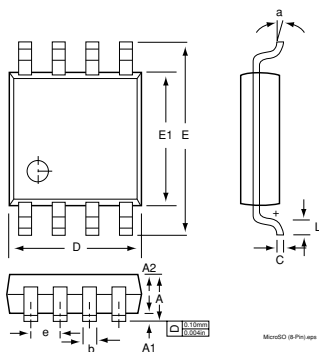

	Inches		Millimeters	
	Min	Max	Min	Max
SO (8-Pin)*				
A	0.053	0.069	1.35	1.75
A1	0.004	0.010	0.10	0.25
B	0.013	0.020	0.33	0.51
C	0.007	0.010	0.19	0.25
e	0.050		1.27	
E	0.150	0.157	3.80	4.00
H	0.228	0.244	5.80	6.20
L	0.016	0.050	0.40	1.27
D	0.189	0.197	4.80	2.00
MicroSO (8-Pin)**				
A	—	0.0433	—	1.10
A1	0.0020	0.0059	0.050	0.15
A2	0.0295	0.0374	0.75	0.95
b	0.0098	0.0157	0.25	0.40
C	0.0051	0.0091	0.13	0.23
D	0.1142	0.1220	2.90	3.10
e	0.0256 BSC		0.65 BSC	
E	0.193 BSC		4.90 BSC	
E1	0.1142	0.1220	2.90	3.10
L	0.0157	0.0276	0.40	0.70
a	0°	6°	0°	6°

* JEDEC Drawing MS-012AA

** JEDEC Drawing MO-187AA

803_01.at3



IMP, Inc.
 Corporate Headquarters
 2830 N. First Street
 San Jose, CA 95134-2071
 Tel: 408-432-9100
 Fax: 408-434-0335
 e-mail: info@impinc.com
 http://www.impweb.com

The IMP logo is a registered trademark of IMP, Inc.
 All other company and product names are trademarks of their respective owners.

© 2000 IMP, Inc.
 Printed in USA
 Publication #: 2006
 Revision: B
 Issue Date: 07/11/00
 Type: Product



LittleDiode supplies new, hard to find or obsolete electronic components and semiconductors all over the world.

With over two million different components listed you are sure to find the part you need.

Feel free to visit us today at our online store:

LittleDiode.com

Looking forward to providing you with the best possible service.