

INA125

INSTRUMENTATION AMPLIFIER With Precision Voltage Reference

FEATURES

- **LOW QUIESCENT CURRENT:** 460µA
- **PRECISION VOLTAGE REFERENCE:**
1.24V, 2.5V, 5V or 10V
- **SLEEP MODE**
- **LOW OFFSET VOLTAGE:** 250µV max
- **LOW OFFSET DRIFT:** 2µV/°C max
- **LOW INPUT BIAS CURRENT:** 20nA max
- **HIGH CMR:** 100dB min
- **LOW NOISE:** 38nV/√Hz at f = 1kHz
- **INPUT PROTECTION TO ±40V**
- **WIDE SUPPLY RANGE**
Single Supply: 2.7V to 36V
Dual Supply: ±1.35V to ±18V
- **16-PIN DIP AND SO-16 SOIC PACKAGES**

DESCRIPTION

The INA125 is a low power, high accuracy instrumentation amplifier with a precision voltage reference. It provides complete bridge excitation and precision differential-input amplification on a single integrated circuit.

A single external resistor sets any gain from 4 to 10,000. The INA125 is laser-trimmed for low offset voltage (250µV), low offset drift (2µV/°C), and high common-mode rejection (100dB at G = 100). It operates on single (+2.7V to +36V) or dual (±1.35V to ±18V) supplies.

The voltage reference is externally adjustable with pin-selectable voltages of 2.5V, 5V, or 10V, allowing use with a variety of transducers. The reference voltage is accurate to ±0.5% (max) with ±35ppm/°C drift (max). Sleep mode allows shutdown and duty cycle operation to save power.

The INA125 is available in 16-pin plastic DIP and SO-16 surface-mount packages and is specified for the -40°C to +85°C industrial temperature range.

APPLICATIONS

- **PRESSURE AND TEMPERATURE BRIDGE AMPLIFIERS**
- **INDUSTRIAL PROCESS CONTROL**
- **FACTORY AUTOMATION**
- **MULTI-CHANNEL DATA ACQUISITION**
- **BATTERY OPERATED SYSTEMS**
- **GENERAL PURPOSE INSTRUMENTATION**

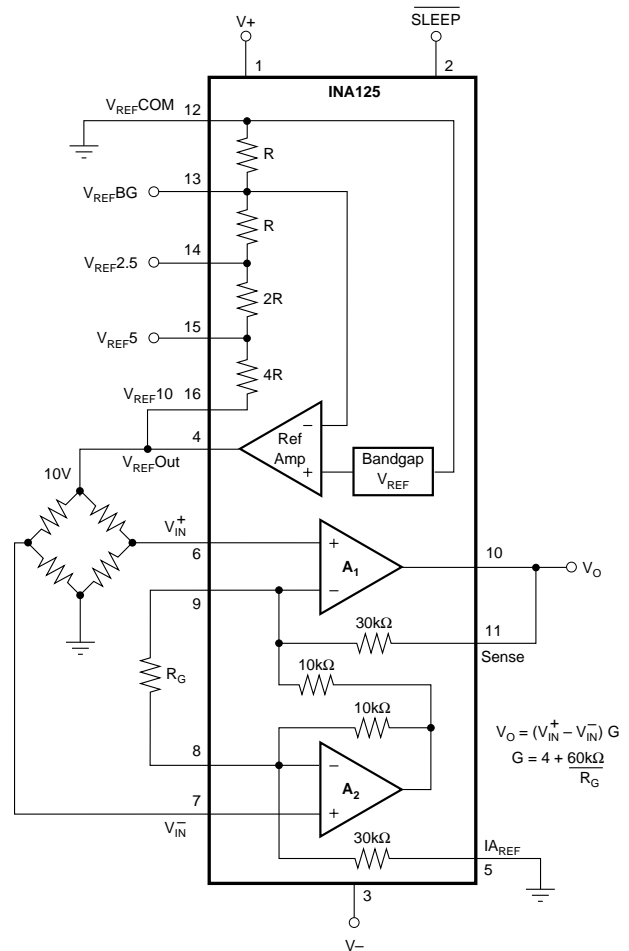

SPECIFICATIONS: $V_S = \pm 15V$

At $T_A = +25^\circ C$, $V_S = \pm 15V$, I_A common = $0V$, V_{REF} common = $0V$, and $R_L = 10k\Omega$, unless otherwise noted.

PARAMETER	CONDITIONS	INA125P, U			INA125PA, UA			UNITS	
		MIN	TYP	MAX	MIN	TYP	MAX		
INPUT									
Offset Voltage, RTI	$V_S = \pm 1.35V$ to $\pm 18V$, $G = 4$		± 50	± 250		*	± 500	μV	
Initial vs Temperature			± 0.25	± 2		*	± 5	$\mu V/^\circ C$	
vs Power Supply			± 3	± 20		*	± 50	$\mu V/V$	
Long-Term Stability				± 0.2		*		$\mu V/mo$	
Impedance, Differential				$10^{11} \parallel 2$		*		$\Omega \parallel pF$	
Common-Mode			$10^{11} \parallel 9$		*		$\Omega \parallel pF$		
Safe Input Voltage			See Text	± 40		*		V	
Input Voltage Range	$V_{CM} = -10.7V$ to $+10.2V$					*			
Common-Mode Rejection		$G = 4$	78	84	72	*		dB	
		$G = 10$	86	94	80	*		dB	
		$G = 100$	100	114	90	*		dB	
	$G = 500$	100	114	90	*		dB		
BIAS CURRENT	$V_{CM} = 0V$		10	25		*	50	nA	
vs Temperature			± 60			*		$pA/^\circ C$	
Offset Current			± 0.5	± 2.5		*	± 5	nA	
vs Temperature			± 0.5			*		$pA/^\circ C$	
NOISE, RTI	$R_S = 0\Omega$					*		nV/\sqrt{Hz}	
Voltage Noise, $f = 10Hz$			40			*		nV/\sqrt{Hz}	
$f = 100Hz$			38			*		nV/\sqrt{Hz}	
$f = 1kHz$			38			*		nV/\sqrt{Hz}	
$f = 0.1Hz$ to $10Hz$			0.8			*		$\mu Vp-p$	
Current Noise, $f = 10Hz$			170			*		fA/\sqrt{Hz}	
$f = 1kHz$			56			*		fA/\sqrt{Hz}	
$f = 0.1Hz$ to $10Hz$			5			*		$pAp-p$	
GAIN									
Gain Equation	$V_O = -14V$ to $+13.3V$	4	$4 + 60k\Omega/R_G$	10,000	*	*	*	V/V	
Range of Gain		$G = 4$		± 0.01	± 0.075		*	± 0.1	%
Gain Error		$G = 10$		± 0.03	± 0.3		*	± 0.5	%
		$G = 100$		± 0.05	± 0.5		*	± 1	%
		$G = 500$		± 0.1			*		%
Gain vs Temperature	$G = 4$		± 1	± 15		*	*	$ppm/^\circ C$	
	$G > 4^{(1)}$		± 25	± 100		*	*	$ppm/^\circ C$	
Nonlinearity	$V_O = -14V$ to $+13.3V$					*			
		$G = 4$		± 0.0004	± 0.002		*	± 0.004	% of FS
		$G = 10$		± 0.0004	± 0.002		*	± 0.004	% of FS
		$G = 100$		± 0.001	± 0.01		*	*	% of FS
	$G = 500$		± 0.002			*		% of FS	
OUTPUT									
Voltage: Positive		$(V+) - 1.7$	$(V+) - 0.9$		*	*		V	
Negative		$(V-) + 1$	$(V-) + 0.4$		*	*		V	
Load Capacitance Stability			1000		*	*		pF	
Short-Circuit Current			$-9/+12$		*	*		mA	
VOLTAGE REFERENCE	$V_{REF} = +2.5V, +5V, +10V$								
Accuracy		$I_L = 0$		± 0.15	± 0.5		*	± 1	%
vs Temperature		$I_L = 0$		± 18	± 35		*	± 100	$ppm/^\circ C$
vs Power Supply, $V+$		$V+ = (V_{REF} + 1.25V)$ to $+36V$		± 20	± 50		*	± 100	ppm/V
vs Load		$I_L = 0$ to $5mA$		3	75		*	*	ppm/mA
Dropout Voltage, $(V+) - V_{REF}^{(2)}$		Ref Load = $2k\Omega$	1.25	1		*	*		V
Bandgap Voltage Reference				1.24		*	*		V
Accuracy		$I_L = 0$		± 0.5		*	*		%
vs Temperature	$I_L = 0$		± 18		*	*		$ppm/^\circ C$	

The information provided herein is believed to be reliable; however, BURR-BROWN assumes no responsibility for inaccuracies or omissions. BURR-BROWN assumes no responsibility for the use of this information, and all use of such information shall be entirely at the user's own risk. Prices and specifications are subject to change without notice. No patent rights or licenses to any of the circuits described herein are implied or granted to any third party. BURR-BROWN does not authorize or warrant any BURR-BROWN product for use in life support devices and/or systems.

SPECIFICATIONS: $V_S = \pm 15V$ (CONT)

At $T_A = +25^\circ C$, $V_S = \pm 15V$, I_A common = 0V, V_{REF} common = 0V, and $R_L = 10k\Omega$, unless otherwise noted.

PARAMETER CONDITIONS		INA125P, U			INA125PA, UA			UNITS
		MIN	TYP	MAX	MIN	TYP	MAX	
FREQUENCY RESPONSE Bandwidth, -3dB	G = 4		150			*		kHz
	G = 10		45			*		kHz
	G = 100		4.5			*		kHz
	G = 500		0.9			*		kHz
Slew Rate	G = 4, 10V Step		0.2			*		V/ μs
Settling Time, 0.01%	G = 4, 10V Step		60			*		μs
	G = 10, 10V Step		83			*		μs
	G = 100, 10V Step		375			*		μs
Overload Recovery	G = 500, 10V Step		1700			*		μs
	50% Overdrive		5			*		μs
POWER SUPPLY Specified Operating Voltage			± 15			*		V
Specified Voltage Range		± 1.35		± 18	*		*	V
Quiescent Current, Positive	$I_O = I_{REF} = 0mA$		460	525		*	*	μA
	$I_O = I_{REF} = 0mA$		-280	-325		*	*	μA
Reference Ground Current ⁽³⁾			180			*	*	μA
Sleep Current ($V_{SLEEP} \leq 100mV$)	$R_L = 10k\Omega$, Ref Load = 2k Ω		± 1	± 25		*	*	μA
SLEEP MODE PIN⁽⁴⁾ V_{IH} (Logic high input voltage)		+2.7		V+	*		*	V
V_{IL} (Logic low input voltage)		0		+0.1	*		*	V
I_{IH} (Logic high input current)			15			*		μA
I_{IL} (Logic low input current)			0			*		μA
Wake-up Time ⁽⁵⁾			150			*		μs
TEMPERATURE RANGE Specification Range		-40		+85	*		*	$^\circ C$
Operation Range		-55		+125	*		*	$^\circ C$
Storage Range		-55		+125	*		*	$^\circ C$
Thermal Resistance, θ_{JA}								
16-Pin DIP			80			*		$^\circ C/W$
SO-16 Surface-Mount			100			*		$^\circ C/W$

* Specification same as INA125P, U.

NOTES: (1) Temperature coefficient of the "Internal Resistor" in the gain equation. Does not include TCR of gain-setting resistor, R_G . (2) Dropout voltage is the positive supply voltage minus the reference voltage that produces a 1% decrease in reference voltage. (3) V_{REFCOM} pin. (4) Voltage measured with respect to Reference Common. Logic low input selects Sleep mode. (5) I_A and Reference, see Typical Performance Curves.

SPECIFICATIONS: $V_S = +5V$

At $T_A = +25^\circ C$, $V_S = +5V$, I_A common at $V_S/2$, V_{REF} common = $V_S/2$, $V_{CM} = V_S/2$, and $R_L = 10k\Omega$ to $V_S/2$, unless otherwise noted.

PARAMETER	CONDITIONS	INA125P, U			INA125PA, UA			UNITS
		MIN	TYP	MAX	MIN	TYP	MAX	
INPUT Offset Voltage, RTI Initial	$V_S = +2.7V$ to $+36V$		± 75	± 500		*	± 750	μV
vs Temperature			± 0.25			*		$\mu V/^\circ C$
vs Power Supply			3	20		*	50	$\mu V/V$
Input Voltage Range	$V_{CM} = +1.1V$ to $+3.6V$		See Text			*		
Common-Mode Rejection		G = 4	78	84	72	*		dB
		G = 10	86	94	80	*		dB
		G = 100	100	114	90	*		dB
		G = 500	100	114	90	*		dB
GAIN Gain Error	$V_O = +0.3V$ to $+3.8V$ G = 4		± 0.01			*		%
OUTPUT Voltage, Positive		(V+)-1.2	(V+)-0.8		*	*		V
Negative		(V-)+0.3	(V-)+0.15		*	*		V
POWER SUPPLY Specified Operating Voltage			+5			*		V
Operating Voltage Range		+2.7		+36	*		*	V
Quiescent Current	$I_O = I_{REF} = 0mA$		460	525		*	*	μA
Sleep Current ($V_{SLEEP} \leq 100mV$)	$R_L = 10k\Omega$, Ref Load = 2k Ω		± 1	± 25		*	*	μA

* Specification same as INA125P, U.

PIN CONFIGURATION

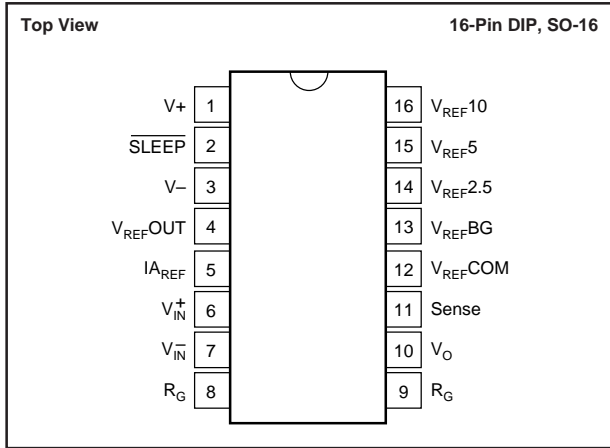

ABSOLUTE MAXIMUM RATINGS⁽¹⁾

Power Supply Voltage, V+ to V-	36V
Input Signal Voltage	±40V
Output Short Circuit	Continuous
Operating Temperature	-55°C to +125°C
Storage Temperature	-55°C to +125°C
Lead Temperature (soldering, 10s)	+300°C

NOTE: Stresses above these ratings may cause permanent damage.

PACKAGE INFORMATION

PRODUCT	PACKAGE	PACKAGE DRAWING NUMBER ⁽¹⁾
INA125PA	16-Pin Plastic DIP	180
INA125P	16-Pin Plastic DIP	180
INA125UA	SO-16 Surface-Mount	265
INA125U	SO-16 Surface-Mount	265

NOTES: (1) For detailed drawing and dimension table, please see end of data sheet, or Appendix C of Burr-Brown IC Data Book.

ELECTROSTATIC DISCHARGE SENSITIVITY

This integrated circuit can be damaged by ESD. Burr-Brown recommends that all integrated circuits be handled with appropriate precautions. Failure to observe proper handling and installation procedures can cause damage.

ESD damage can range from subtle performance degradation to complete device failure. Precision integrated circuits may be more susceptible to damage because very small parametric changes could cause the device not to meet its published specifications.

TYPICAL PERFORMANCE CURVES

At $T_A = +25^\circ\text{C}$ and $V_S = \pm 15\text{V}$, unless otherwise noted.

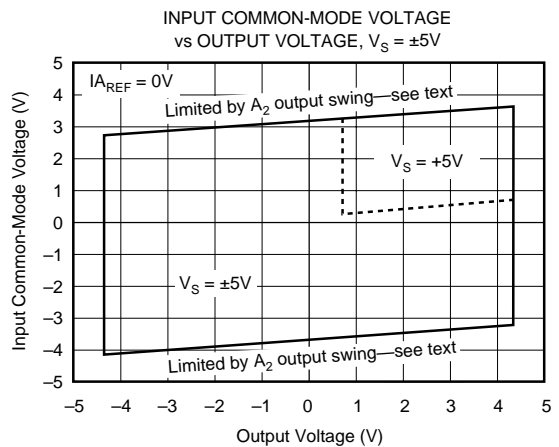
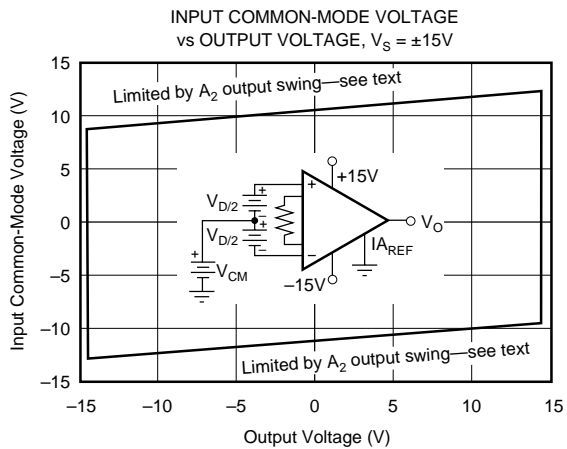
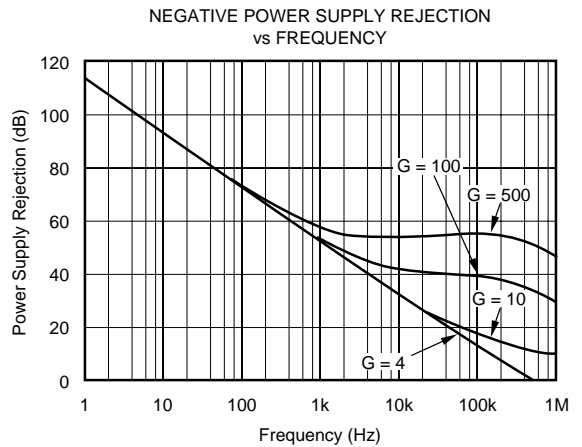
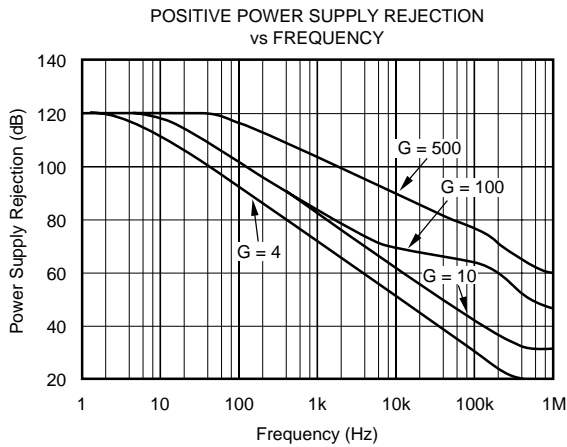
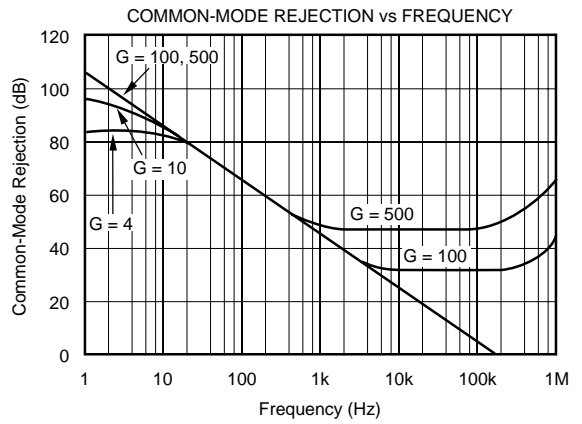
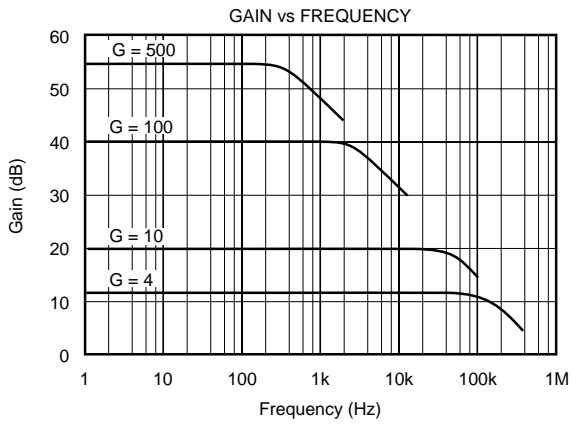

TYPICAL PERFORMANCE CURVES (CONT)

At $T_A = +25^\circ\text{C}$ and $V_S = \pm 15\text{V}$, unless otherwise noted.

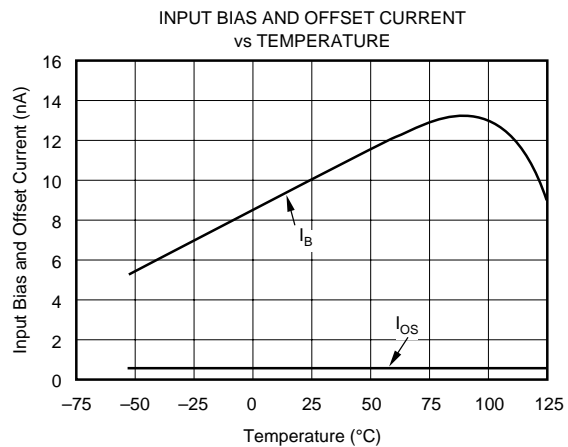
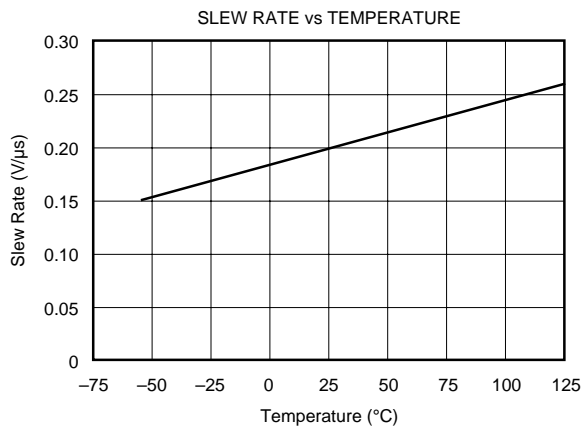
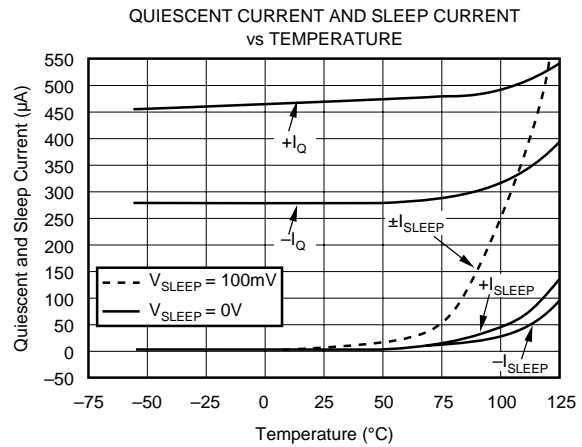
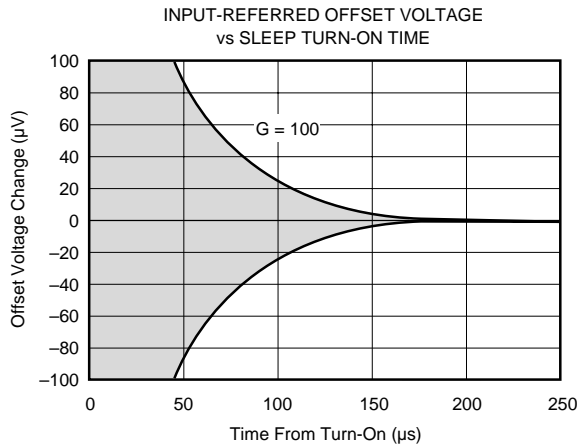
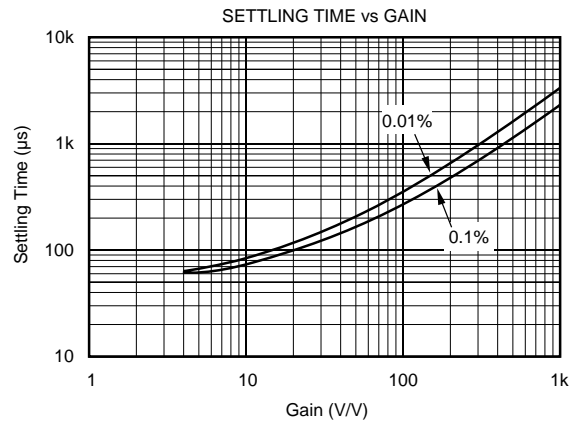
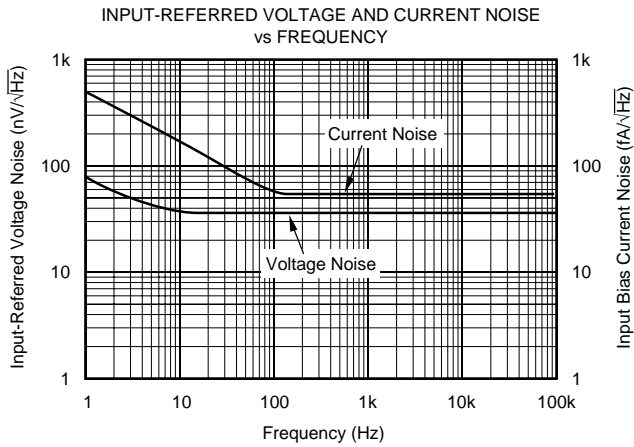

TYPICAL PERFORMANCE CURVES (CONT)

At $T_A = +25^\circ\text{C}$ and $V_S = \pm 15\text{V}$, unless otherwise noted.

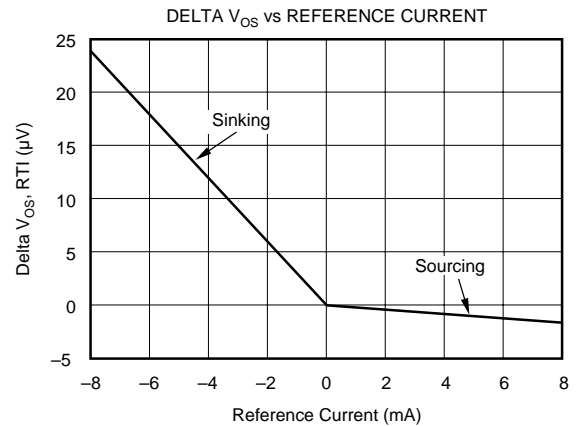
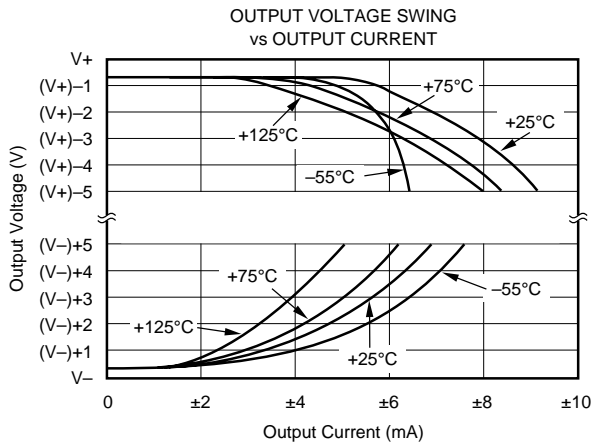
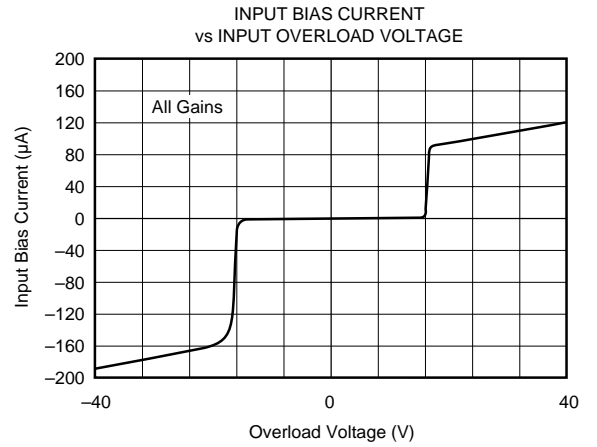
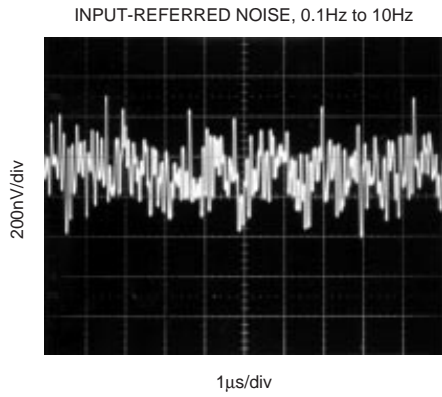
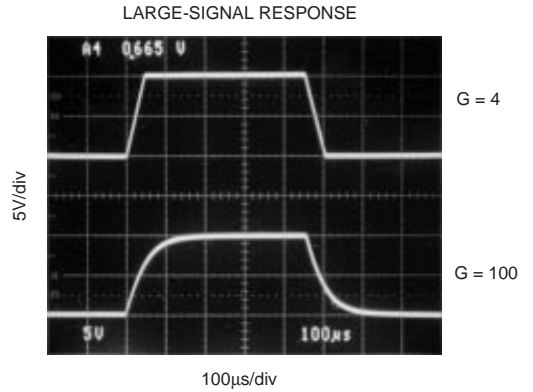
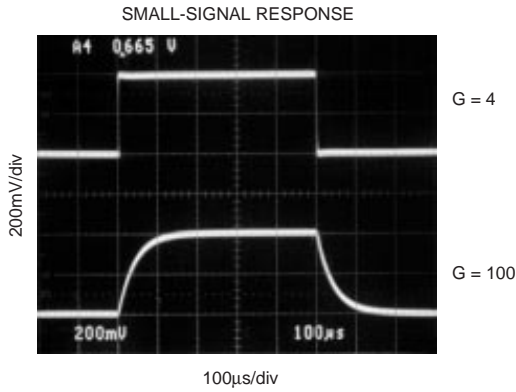

TYPICAL PERFORMANCE CURVES (CONT)

At $T_A = +25^\circ\text{C}$ and $V_S = \pm 15\text{V}$, unless otherwise noted.

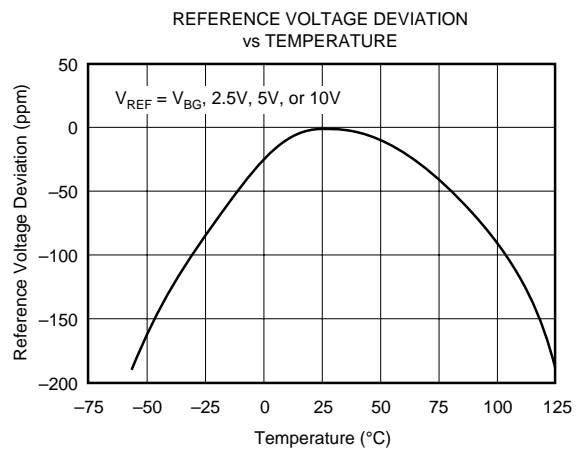
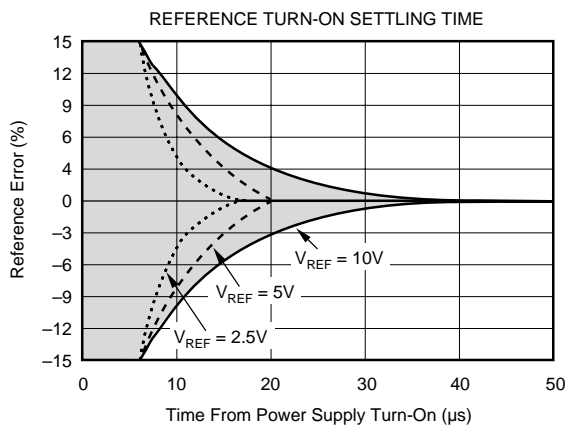
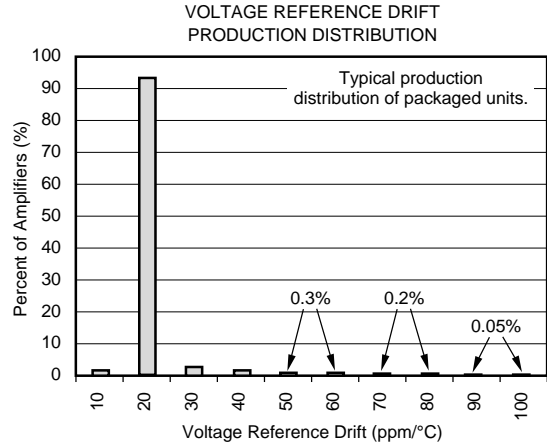
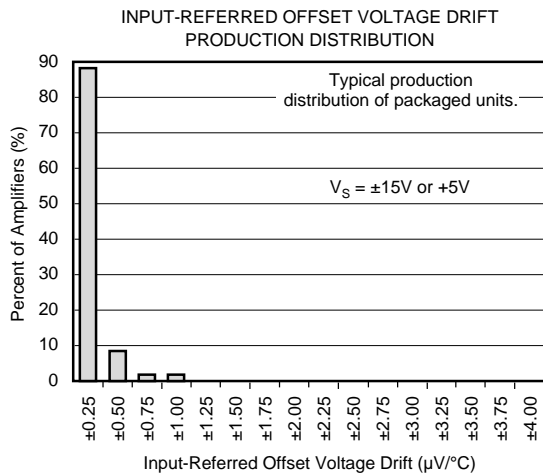
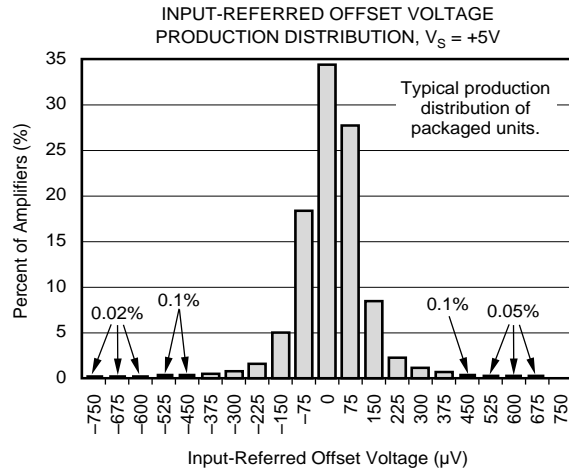
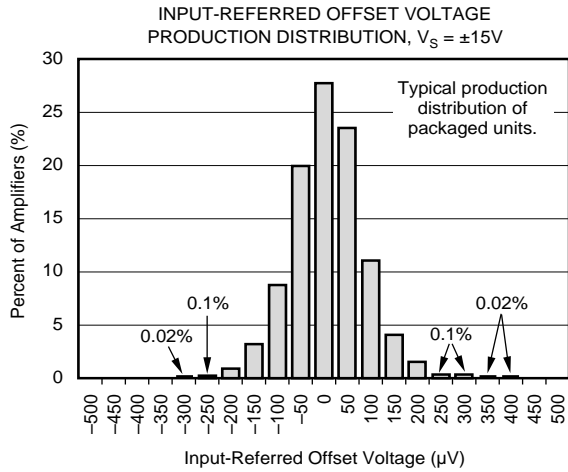

TYPICAL PERFORMANCE CURVES (CONT)

At $T_A = +25^\circ\text{C}$ and $V_S = \pm 15\text{V}$, unless otherwise noted.

0.1Hz to 10Hz REFERENCE NOISE
 $V_{REF} = 2.5\text{V}$, $C_L = 100\text{pF}$

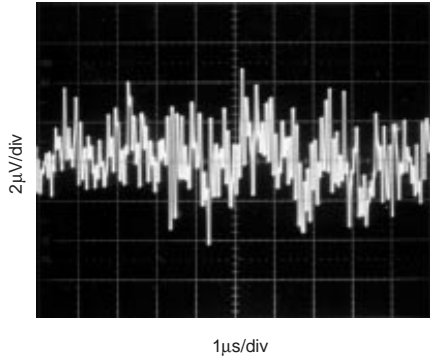

REFERENCE TRANSIENT RESPONSE
 $V_{REF} = 2.5\text{V}$, $C_L = 100\text{pF}$

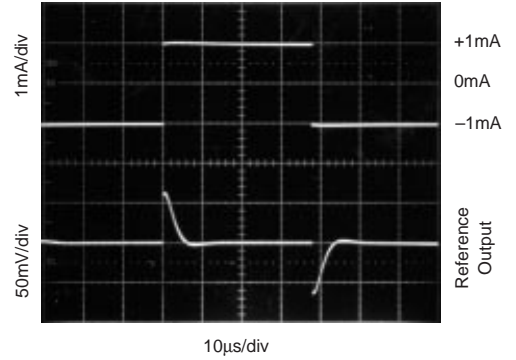

POSITIVE REFERENCE AC LINE REJECTION
 vs FREQUENCY

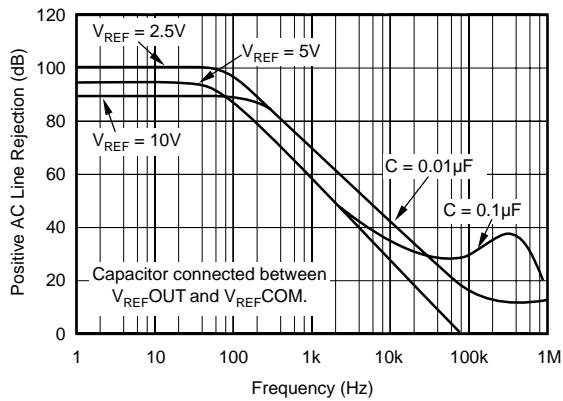

NEGATIVE REFERENCE AC LINE REJECTION
 vs FREQUENCY

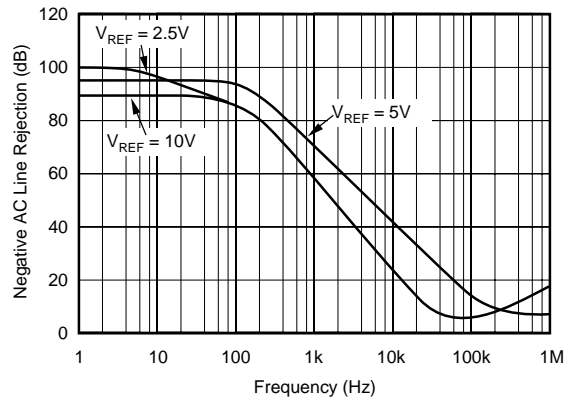

APPLICATION INFORMATION

Figure 1 shows the basic connections required for operation of the INA125. Applications with noisy or high impedance power supplies may require decoupling capacitors close to the device pins as shown.

The output is referred to the instrumentation amplifier reference (I_{A_REF}) terminal which is normally grounded. This must be a low impedance connection to assure good common-mode rejection. A resistance of 12Ω in series with the I_{A_REF} pin will cause a typical device to degrade to approximately 80dB CMR ($G = 4$).

Connecting V_{REF_OUT} (pin 4) to one of the four available reference voltage pins (V_{REF_BG} , $V_{REF_2.5}$, V_{REF_5} , or V_{REF_10}) provides an accurate voltage source for bridge applications.

For example, in Figure 1 V_{REF_OUT} is connected to V_{REF_10} thus supplying 10V to the bridge. It is recommended that V_{REF_OUT} be connected to one of the reference voltage pins even when the reference is not being utilized to avoid saturating the reference amplifier. Driving the $SLEEP$ pin LOW puts the INA125 in a shutdown mode.

SETTING THE GAIN

Gain of the INA125 is set by connecting a single external resistor, R_G , between pins 8 and 9:

$$G = 4 + \frac{60k\Omega}{R_G} \quad (1)$$

Commonly used gains and R_G resistor values are shown in Figure 1.

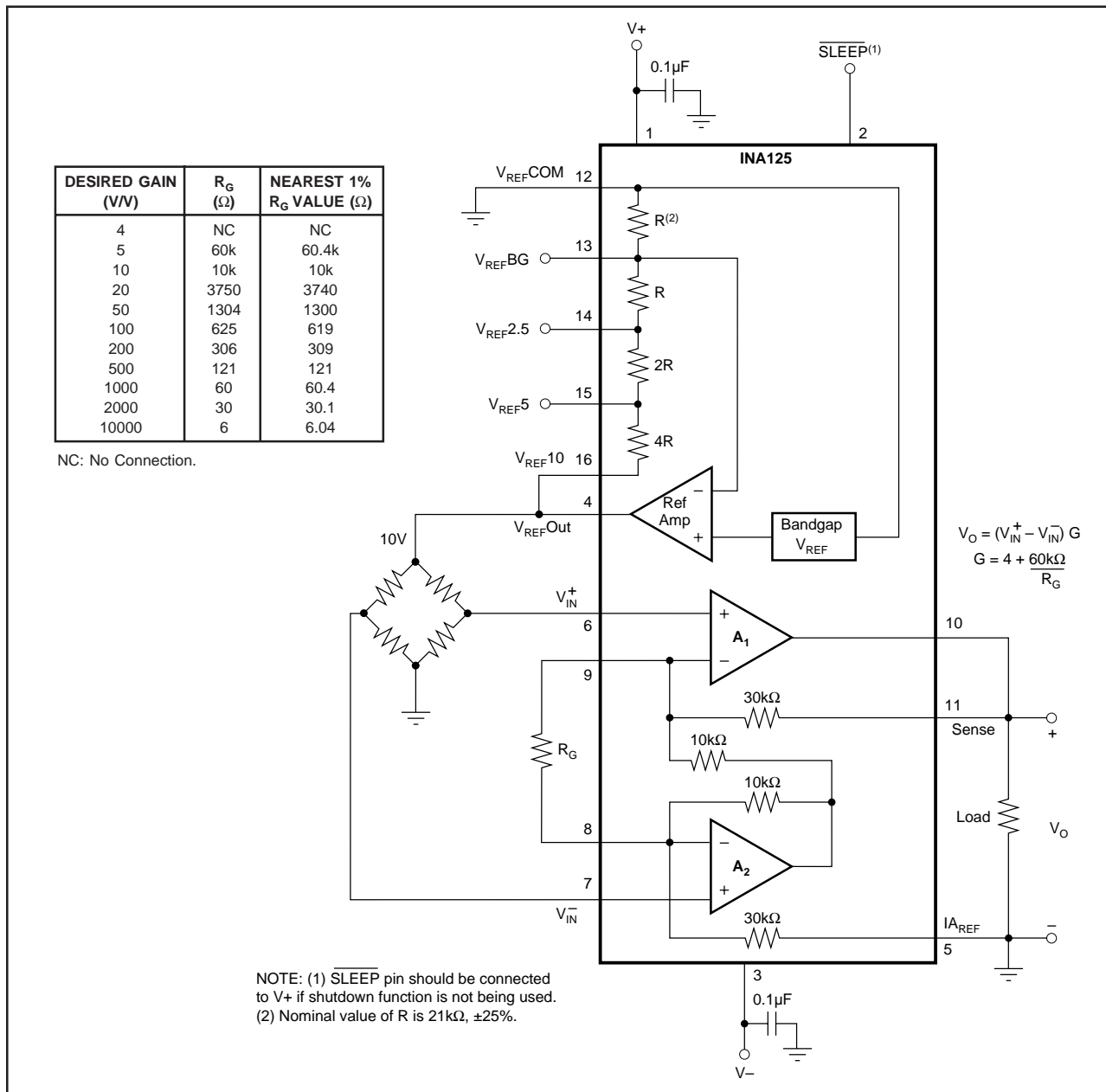

FIGURE 1. Basic Connections.

The 60kΩ term in equation 1 comes from the internal metal film resistors which are laser trimmed to accurate absolute values. The accuracy and temperature coefficient of these resistors are included in the gain accuracy and drift specifications of the INA125.

The stability and temperature drift of the external gain setting resistor, R_G , also affects gain. R_G 's contribution to gain accuracy and drift can be directly inferred from the gain equation (1). Low resistor values required for high gain can make wiring resistance important. Sockets add to the wiring resistance, which will contribute additional gain error (possibly an unstable gain error) in gains of approximately 100 or greater.

OFFSET TRIMMING

The INA125 is laser trimmed for low offset voltage and offset voltage drift. Most applications require no external offset adjustment. Figure 2 shows an optional circuit for trimming the output offset voltage. The voltage applied to the $I_{A_{REF}}$ terminal is added to the output signal. The op amp buffer is used to provide low impedance at the $I_{A_{REF}}$ terminal to preserve good common-mode rejection.

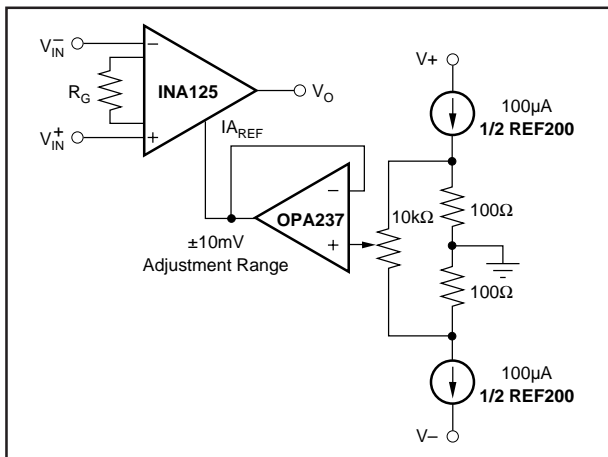

FIGURE 2. Optional Trimming of Output Offset Voltage.

INPUT BIAS CURRENT RETURN

The input impedance of the INA125 is extremely high—approximately $10^{11}\Omega$. However, a path must be provided for the input bias current of both inputs. This input bias current flows out of the device and is approximately 10nA. High input impedance means that this input bias current changes very little with varying input voltage.

Input circuitry must provide a path for this input bias current for proper operation. Figure 3 shows various provisions for an input bias current path. Without a bias current path, the inputs will float to a potential which exceeds the common-mode range, and the input amplifiers will saturate.

If the differential source resistance is low, the bias current return path can be connected to one input (see the thermocouple example in Figure 3). With higher source impedance, using two equal resistors provides a balanced input with possible advantages of lower input offset voltage due to bias current and better high frequency common-mode rejection.

INPUT COMMON-MODE RANGE

The input common-mode range of the INA125 is shown in the typical performance curves. The common-mode range is limited on the negative side by the output voltage swing of A_2 , an internal circuit node that cannot be measured on an external pin. The output voltage of A_2 can be expressed as:

$$V_{O2} = 1.3V_{IN}^- - (V_{IN}^+ - V_{IN}^-) (10k\Omega/R_G)$$

(voltages referred to $I_{A_{REF}}$ terminal, pin 5)

The internal op amp A_2 is identical to A_1 . Its output swing is limited to approximately 0.8V from the positive supply and 0.25V from the negative supply. When the input common-mode range is exceeded (A_2 's output is saturated), A_1 can still be in linear operation, responding to changes in the non-inverting input voltage. The output voltage, however, will be invalid.

PRECISION VOLTAGE REFERENCE

The on-board precision voltage reference provides an accurate voltage source for bridge and other transducer applications or ratiometric conversion with analog-to-digital converters. A reference output of 2.5V, 5V or 10V is available by connecting V_{REFOUT} (pin 4) to one of the V_{REF} pins ($V_{REF2.5}$, V_{REF5} , or V_{REF10}). Reference voltages are laser-trimmed for low initial error and low temperature drift. Connecting V_{REFOUT} to V_{REFBG} (pin 13) produces the bandgap reference voltage ($1.24V \pm 0.5\%$) at the reference output.

Positive supply voltage must be 1.25V above the desired reference voltage. For example, with $V_+ = 2.7V$, only the 1.24V reference (V_{REFBG}) can be used. If using dual supplies V_{REFCOM} can be connected to V_- , increasing the

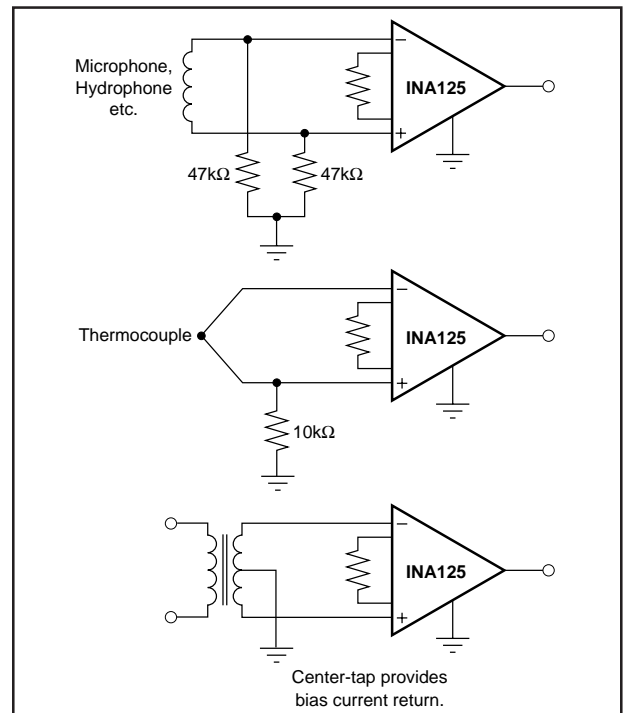

FIGURE 3. Providing an Input Common-Mode Current Path.

amount of supply voltage headroom available to the reference. Approximately $180\mu\text{A}$ flows out of the V_{REFCOM} terminal, therefore, it is recommended that it be connected through a low impedance path to sensor common to avoid possible ground loop problems.

Reference noise is proportional to the reference voltage selected. With $V_{\text{REF}} = 2.5\text{V}$, 0.1Hz to 10Hz peak-to-peak noise is approximately $9\mu\text{Vp-p}$. Noise increases to $36\mu\text{Vp-p}$ for the 10V reference. Output drive capability of the voltage reference is improved by connecting a transistor as shown in Figure 4. The external transistor also serves to remove power from the INA125.

Internal resistors that set the voltage reference output are ratio-trimmed for accurate output voltages ($\pm 0.5\%$ max). The absolute resistance values, however, may vary $\pm 25\%$. Adjustment of the reference output voltage with an external resistor is not recommended because the required resistor value is uncertain.

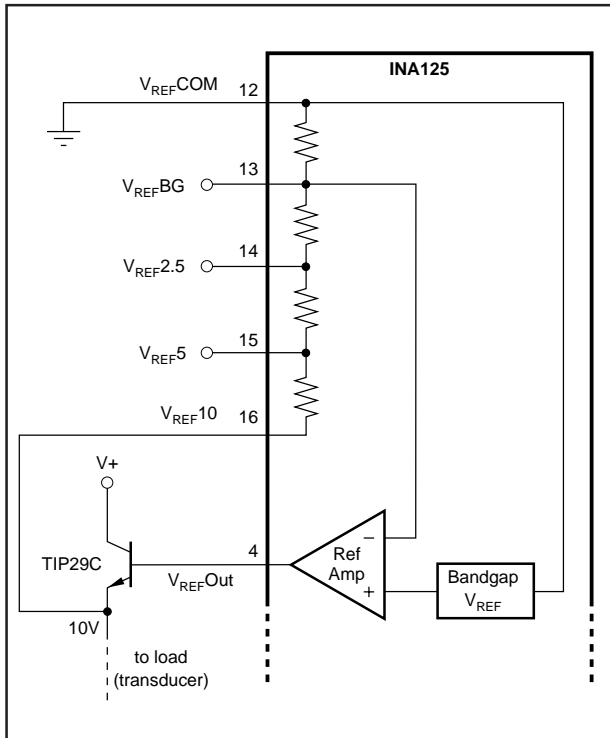

FIGURE 4. Reference Current Boost.

SHUTDOWN

The INA125 has a shutdown option. When the $\overline{\text{SLEEP}}$ pin is LOW (100mV or less), the supply current drops to approximately $1\mu\text{A}$ and output impedance becomes approximately $80\text{k}\Omega$. Best performance is achieved with CMOS logic. To maintain low sleep current at high temperatures, V_{SLEEP} should be as close to 0V as possible. This should not be a problem if using CMOS logic unless the CMOS gate is driving other currents. Refer to the typical performance curve, “Sleep Current vs Temperature.”

A transition region exists when V_{SLEEP} is between 400mV and 2.7V (with respect to V_{REFCOM}) where the output is unpredictable. Operation in this region is not recommended. The INA125 achieves high accuracy quickly following wake-up ($V_{\text{SLEEP}} \geq 2.7\text{V}$). See the typical performance curve “Input-Referred Offset Voltage vs Sleep Turn-on Time.” If shutdown is not being used, connect the $\overline{\text{SLEEP}}$ pin to $V+$.

LOW VOLTAGE OPERATION

The INA125 can be operated on power supplies as low as $\pm 1.35\text{V}$. Performance remains excellent with power supplies ranging from $\pm 1.35\text{V}$ to $\pm 18\text{V}$. Most parameters vary only slightly throughout this supply voltage range—see typical performance curves. Operation at very low supply voltage requires careful attention to ensure that the common-mode voltage remains within its linear range. See “Input Common-Mode Voltage Range.” As previously mentioned, when using the on-board reference with low supply voltages, it may be necessary to connect V_{REFCOM} to $V-$ to ensure $V_S - V_{\text{REF}} \geq 1.25\text{V}$.

SINGLE SUPPLY OPERATION

The INA125 can be used on single power supplies of +2.7V to +36V. Figure 5 shows a basic single supply circuit. The I_{AREF} , V_{REFCOM} , and $V-$ terminals are connected to ground. Zero differential input voltage will demand an output voltage of 0V (ground). When the load is referred to ground as shown, actual output voltage swing is limited to approximately 150mV above ground. The typical performance curve “Output Voltage Swing vs Output Current” shows how the output swing varies with output current.

With single supply operation, careful attention should be paid to input common-mode range, output voltage swing of both op amps, and the voltage applied to the I_{AREF} terminal. $V_{\text{IN+}}$ and $V_{\text{IN-}}$ must both be 1V above ground for linear operation. You cannot, for instance, connect the inverting input to ground and measure a voltage connected to the non-inverting input.

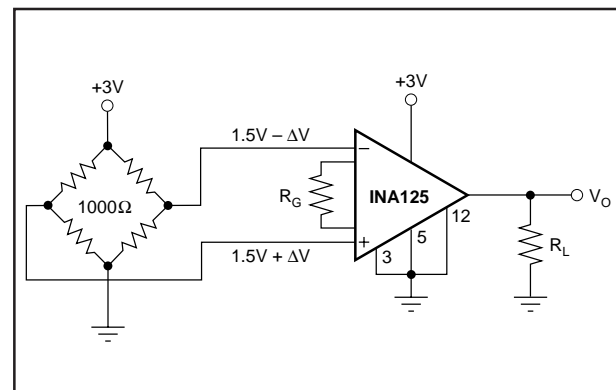

FIGURE 5. Single Supply Bridge Amplifier.

INPUT PROTECTION

The inputs of the INA125 are individually protected for voltage up to $\pm 40\text{V}$. For example, a condition of -40V on one input and $+40\text{V}$ on the other input will not cause damage. Internal circuitry on each input provides low series impedance under normal signal conditions. To provide equivalent protection, series input resistors would contribute

excessive noise. If the input is overloaded, the protection circuitry limits the input current to a safe value of approximately $120\mu\text{A}$ to $190\mu\text{A}$. The typical performance curve "Input Bias Current vs Input Overload Voltage" shows this input current limit behavior. The inputs are protected even if the power supplies are disconnected or turned off.

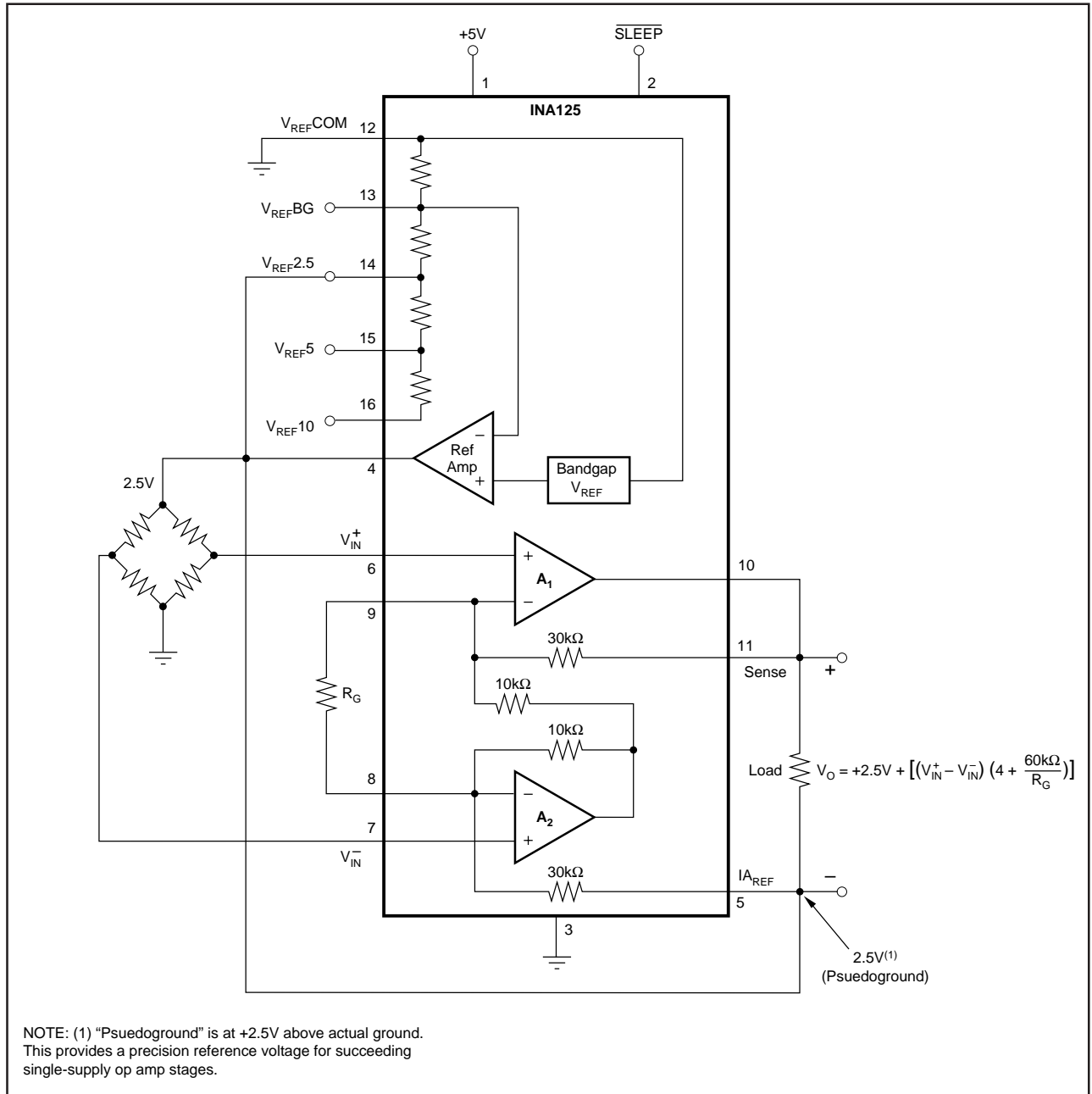

FIGURE 6. Pseudoground Bridge Measurement, 5V Single Supply.

This datasheet has been downloaded from:

www.DatasheetCatalog.com

Datasheets for electronic components.



LittleDiode supplies new, hard to find or obsolete electronic components and semiconductors all over the world.

With over two million different components listed you are sure to find the part you need.

Feel free to visit us today at our online store:

LittleDiode.com

Looking forward to providing you with the best possible service.