

**INA126**  
**INA2126**

## MicroPOWER INSTRUMENTATION AMPLIFIER

### Single and Dual Versions

#### FEATURES

- **LOW QUIESCENT CURRENT:** 175µA/chan.
- **WIDE SUPPLY RANGE:** ±1.35V to ±18V
- **LOW OFFSET VOLTAGE:** 250µV max
- **LOW OFFSET DRIFT:** 3µV/°C max
- **LOW NOISE:** 35nV/√Hz
- **LOW INPUT BIAS CURRENT:** 25nA max
- **8-PIN DIP, SO-8, MSOP-8 SURFACE-MOUNT**  
**DUAL: 16-Pin DIP, SO-16, SSOP-16**

#### APPLICATIONS

- **INDUSTRIAL SENSOR AMPLIFIER:**  
Bridge, RTD, Thermocouple
- **PHYSIOLOGICAL AMPLIFIER:**  
ECG, EEG, EMG
- **MULTI-CHANNEL DATA ACQUISITION**
- **PORTABLE, BATTERY OPERATED SYSTEMS**

#### DESCRIPTION

The INA126 and INA2126 are precision instrumentation amplifiers for accurate, low noise differential signal acquisition. Their two-op-amp design provides excellent performance with very low quiescent current (175µA/chan.). This, combined with wide operating voltage range of ±1.35V to ±18V, makes them ideal for portable instrumentation and data acquisition systems.

Gain can be set from 5V/V to 10000V/V with a single external resistor. Laser trimmed input circuitry provides low offset voltage (250µV max), low offset voltage drift (3µV/°C max) and excellent common-mode rejection.

Single version package options include 8-pin plastic DIP, SO-8 surface mount, and fine-pitch MSOP-8 surface-mount. Dual version is available in the space-saving SSOP-16 fine-pitch surface mount, SO-16, and 16-pin DIP. All are specified for the -40°C to +85°C industrial temperature range.

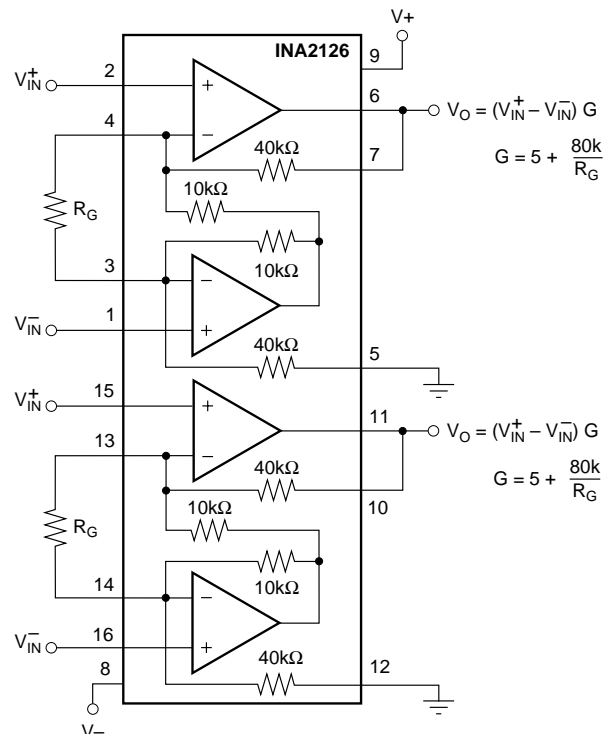
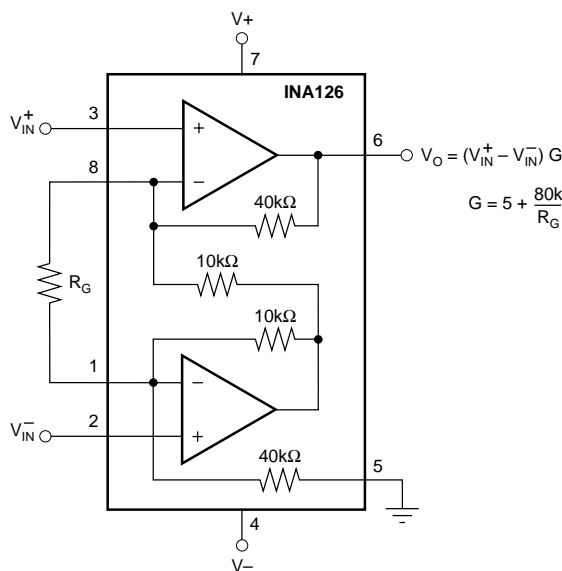

International Airport Industrial Park • Mailing Address: PO Box 11400, Tucson, AZ 85734 • Street Address: 6730 S. Tucson Blvd., Tucson, AZ 85706 • Tel: (520) 746-1111 • Twx: 910-952-1111  
Internet: <http://www.burr-brown.com/> • FAXLine: (800) 548-6133 (US/Canada Only) • Cable: BBRCORP • Telex: 066-6491 • FAX: (520) 889-1510 • Immediate Product Info: (800) 548-6132

# SPECIFICATIONS

At  $T_A = +25^\circ\text{C}$ ,  $V_S = \pm 15\text{V}$ ,  $R_L = 25\text{k}\Omega$ , unless otherwise noted.

PARAMETER	CONDITIONS	INA126P, U, E INA2126P, U, E			INA126PA, UA, EA INA2126PA, UA, EA			UNITS
		MIN	TYP	MAX	MIN	TYP	MAX	
<b>INPUT</b>								
Offset Voltage, RTI vs Temperature	$V_S = \pm 1.35\text{V to } \pm 18\text{V}$		$\pm 100$	$\pm 250$		$\pm 150$	$\pm 500$	$\mu\text{V}$
vs Power Supply (PSRR)			$\pm 0.5$	$\pm 3$		*	$\pm 5$	$\mu\text{V}/^\circ\text{C}$
Input Impedance				5	15		*	50
Safe Input Voltage	$R_S = 0$	$(V^-) - 0.5$						$\Omega \parallel \text{pF}$
	$R_S = 1\text{k}\Omega$	$(V^-) - 10$						V
Common-Mode Voltage Range	$V_O = 0\text{V}$	$\pm 11.25$	$\pm 11.5$	$(V^+) + 0.5$	*	*	*	V
Channel Separation (dual)	$G = 5, \text{dc}$		130	$(V^+) + 10$	*	*	*	dB
Common-Mode Rejection INA2126U (dual SO-16)	$R_S = 0, V_{CM} = \pm 11.25\text{V}$	83	94		74	90		dB
		80	94					dB
<b>INPUT BIAS CURRENT</b>								
vs Temperature			-10	-25		*	-50	nA
Offset Current			$\pm 30$			*		$\text{pA}/^\circ\text{C}$
vs Temperature			$\pm 0.5$	$\pm 2$		*	$\pm 5$	nA
			$\pm 10$			*		$\text{pA}/^\circ\text{C}$
<b>GAIN</b>								
Gain Equation			$G = 5 \text{ to } 10\text{k}$			*		V/V
Gain Error	$V_O = \pm 14\text{V}, G = 5$		$G = 5 + 80\text{k}\Omega/R_G$			*		V/V
vs Temperature	$G = 5$		$\pm 0.02$	$\pm 0.1$		*	$\pm 0.18$	%
Gain Error	$V_O = \pm 12\text{V}, G = 100$		$\pm 2$	$\pm 10$		*	*	$\text{ppm}/^\circ\text{C}$
vs Temperature	$G = 100$		$\pm 0.2$	$\pm 0.5$		*	$\pm 1$	%
Nonlinearity	$G = 100, V_O = \pm 14\text{V}$		$\pm 25$	$\pm 100$		*	*	$\text{ppm}/^\circ\text{C}$
			$\pm 0.002$	$\pm 0.012$		*	*	%
<b>NOISE</b>								
Voltage Noise, $f = 1\text{kHz}$			35			*		$\text{nV}/\sqrt{\text{Hz}}$
$f = 100\text{Hz}$			35			*		$\text{nV}/\sqrt{\text{Hz}}$
$f = 10\text{Hz}$			45			*		$\text{nV}/\sqrt{\text{Hz}}$
$f_B = 0.1\text{Hz to } 10\text{Hz}$			0.7			*		$\mu\text{Vp-p}$
Current Noise, $f = 1\text{kHz}$			60			*		$\text{fA}/\sqrt{\text{Hz}}$
$f_B = 0.1\text{Hz to } 10\text{Hz}$			2			*		$\text{pAp-p}$
<b>OUTPUT</b>								
Voltage, Positive	$R_L = 25\text{k}\Omega$	$(V^+) - 0.9$	$(V^+) - 0.75$		*	*		V
Negative	$R_L = 25\text{k}\Omega$	$(V^-) + 0.95$	$(V^-) + 0.8$		*	*		V
Short-Circuit Current	Short-Circuit to Ground		$+10/-5$			*		mA
Capacitive Load Drive			1000			*		pF
<b>FREQUENCY RESPONSE</b>								
Bandwidth, -3dB	$G = 5$		200			*		kHz
	$G = 100$		9			*		kHz
	$G = 500$		1.8			*		kHz
Slew Rate	$V_O = \pm 10\text{V}, G = 5$		0.4			*		$\text{V}/\mu\text{s}$
Settling Time, 0.01%	10V Step, $G = 5$		30			*		$\mu\text{s}$
	10V Step, $G = 100$		160			*		$\mu\text{s}$
	10V Step, $G = 500$		1500			*		$\mu\text{s}$
Overload Recovery	50% Input Overload		4			*		$\mu\text{s}$
<b>POWER SUPPLY</b>								
Voltage Range		$\pm 1.35$	$\pm 15$	$\pm 18$	*	*	*	V
Current (per channel)	$I_O = 0$		$\pm 175$	$\pm 200$		*	*	$\mu\text{A}$
<b>TEMPERATURE RANGE</b>								
Specification Range		-40		+85	*		*	$^\circ\text{C}$
Operation Range		-55		+125	*		*	$^\circ\text{C}$
Storage Range		-55		+125	*		*	$^\circ\text{C}$
Thermal Resistance, $\theta_{JA}$								
8-Pin DIP			100			*		$^\circ\text{C}/\text{W}$
SO-8 Surface-Mount			150			*		$^\circ\text{C}/\text{W}$
MSOP-8 Surface-Mount			200			*		$^\circ\text{C}/\text{W}$
16-Pin DIP (dual)			80			*		$^\circ\text{C}/\text{W}$
SO-16 (dual)			100			*		$^\circ\text{C}/\text{W}$
SSOP-16 (dual)			100			*		$^\circ\text{C}/\text{W}$

\* Specification same as INA126P, INA126U, INA126E; INA2126P, INA2126U, INA2126E.

The information provided herein is believed to be reliable; however, BURR-BROWN assumes no responsibility for inaccuracies or omissions. BURR-BROWN assumes no responsibility for the use of this information, and all use of such information shall be entirely at the user's own risk. Prices and specifications are subject to change without notice. No patent rights or licenses to any of the circuits described herein are implied or granted to any third party. BURR-BROWN does not authorize or warrant any BURR-BROWN product for use in life support devices and/or systems.



## PIN CONFIGURATION (Single)

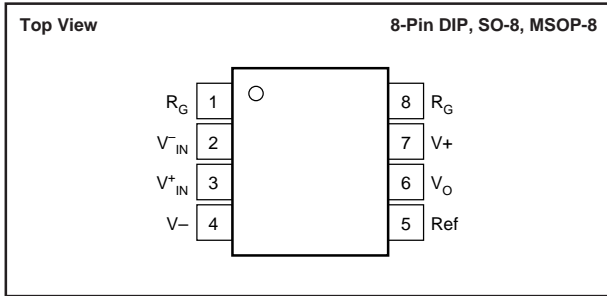

## ABSOLUTE MAXIMUM RATINGS<sup>(1)</sup>

Power Supply Voltage, $V_+$ to $V_-$ .....	36V
Input Signal Voltage <sup>(2)</sup> .....	$(V_-)-0.7$ to $(V_+)+0.7V$
Input Signal Current <sup>(2)</sup> .....	10mA
Output Short Circuit .....	Continuous
Operating Temperature .....	$-55^\circ\text{C}$ to $+125^\circ\text{C}$
Storage Temperature .....	$-55^\circ\text{C}$ to $+125^\circ\text{C}$
Lead Temperature (soldering, 10s) .....	$+300^\circ\text{C}$

NOTES: (1) Stresses above these ratings may cause permanent damage.  
 (2) Input signal voltage is limited by internal diodes connected to power supplies. See text.

## ELECTROSTATIC DISCHARGE SENSITIVITY

This integrated circuit can be damaged by ESD. Burr-Brown recommends that all integrated circuits be handled with appropriate precautions. Failure to observe proper handling and installation procedures can cause damage.

ESD damage can range from subtle performance degradation to complete device failure. Precision integrated circuits may be more susceptible to damage because very small parametric changes could cause the device not to meet its published specifications.

## PIN CONFIGURATION (Dual)

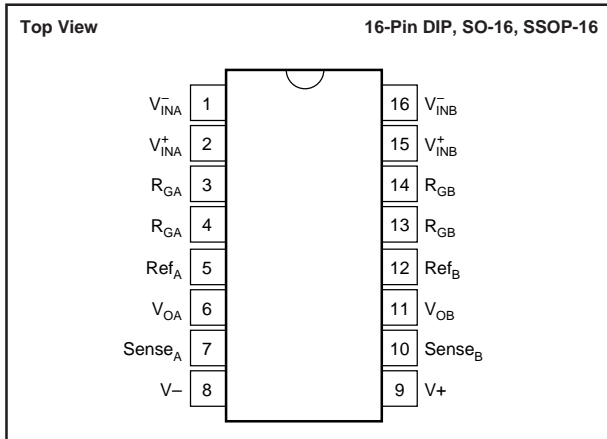

## PACKAGE INFORMATION

PRODUCT	PACKAGE	PACKAGE DRAWING NUMBER <sup>(1)</sup>	PACKAGE MARKING	ORDERING NUMBER	TRANSPORT MEDIA
<b>Single</b>					
INA126PA	8-Pin DIP	006	INA126PA	INA126PA	Rails
INA126P	8-Pin DIP	006	INA126P	INA126P	Rails
INA126UA	SO-8	182	INA126UA	INA126UA	Rails or Reel
INA126U	SO-8	182	INA126U	INA126U	Rails or Reel
INA126EA <sup>(2)</sup>	MSOP-8	337	A26 <sup>(3)</sup>	INA126EA-250	Reel Only
"	"	"	"	INA126EA-2500	"
INA126E <sup>(2)</sup>	MSOP-8	337	A26 <sup>(3)</sup>	INA126E-250	Reel Only
"	"	"	"	INA126E-2500	"
<b>Dual</b>					
INA2126PA	16-Pin DIP	180	INA2126PA	INA2126PA	Rails
INA2126P	16-Pin DIP	180	INA2126P	INA2126P	Rails
INA2126UA	SO-16	265	INA2126UA	INA2126UA	Rails
INA2126U	SO-16	265	INA2126U	INA2126U	Rails
INA2126EA <sup>(2)</sup>	SSOP-16	322	INA2126EA	INA2126EA-250	Reel Only
"	"	"	"	INA2126EA-2500	"
INA2126E <sup>(2)</sup>	SSOP-16	322	INA2126E	INA2126E-250	Reel Only
"	"	"	"	INA2126E-2500	"

NOTES: (1) For detailed drawing and dimension table, see end of data sheet, or Appendix C of Burr-Brown IC Data Book. (2) MSOP-8 and SSOP-16 packages are available only on 250 or 2500 piece reels. (3) Grade designation is marked on reel.

# TYPICAL PERFORMANCE CURVES

At  $T_A = +25^\circ\text{C}$  and  $V_S = \pm 15\text{V}$ , unless otherwise noted.

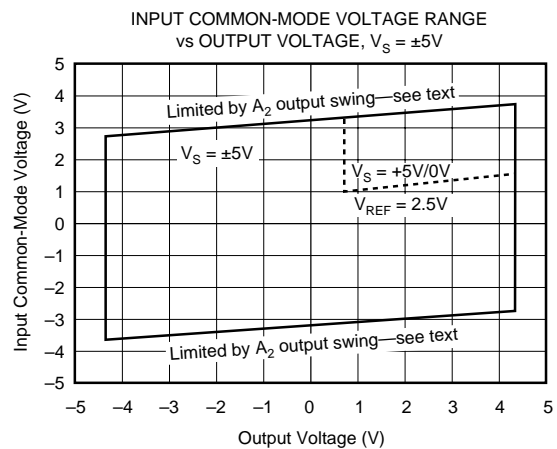
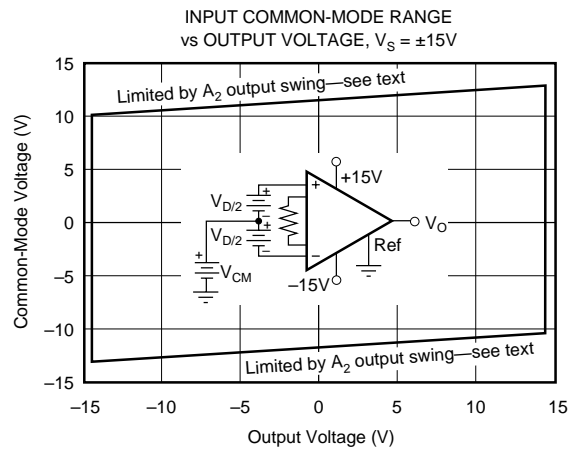
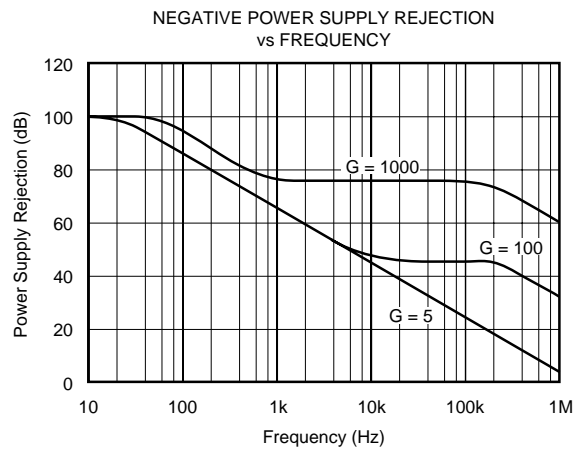
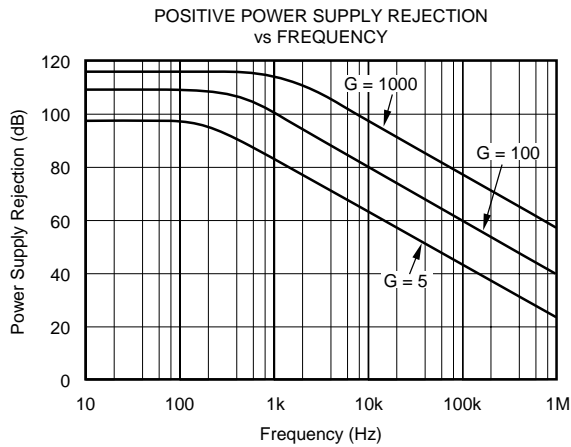
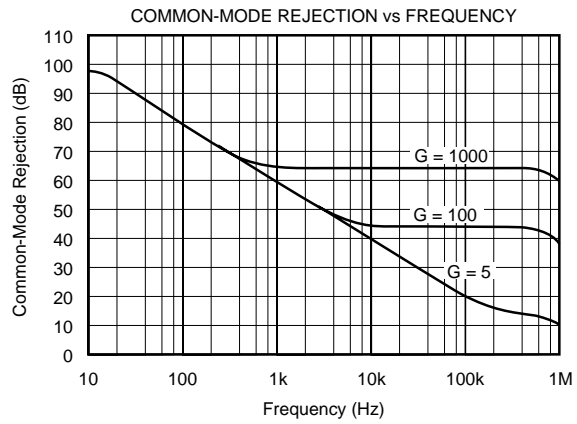
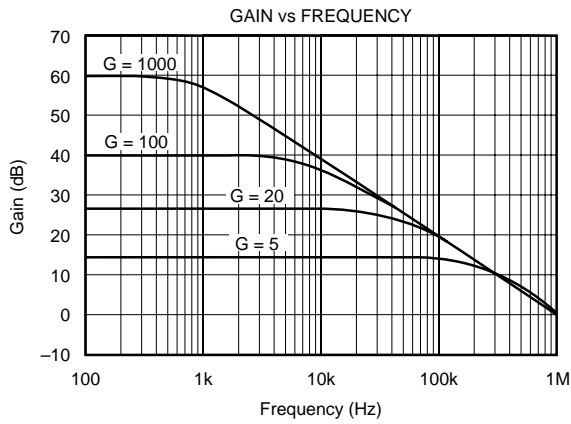

# TYPICAL PERFORMANCE CURVES (CONT)

At  $T_A = +25^\circ\text{C}$  and  $V_S = \pm 15\text{V}$ , unless otherwise noted.

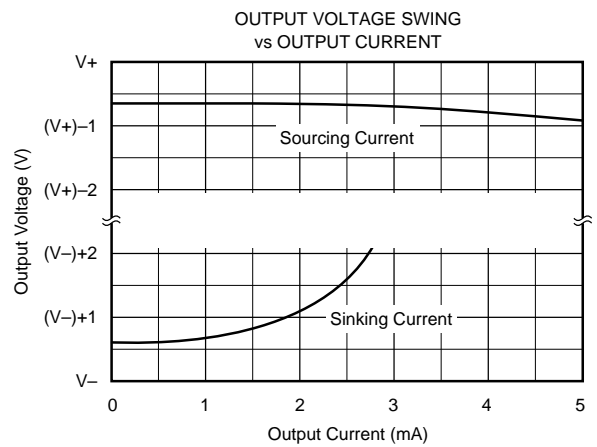
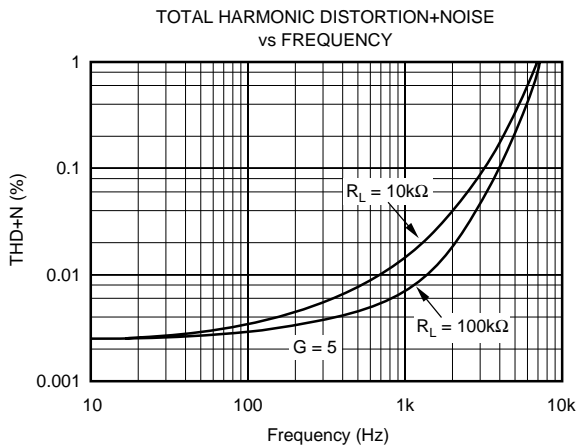
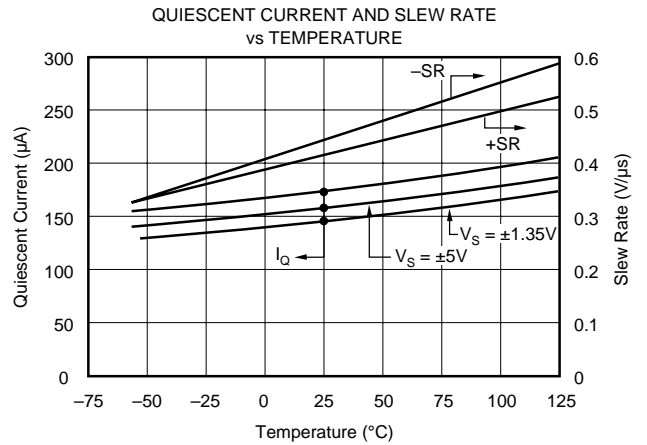
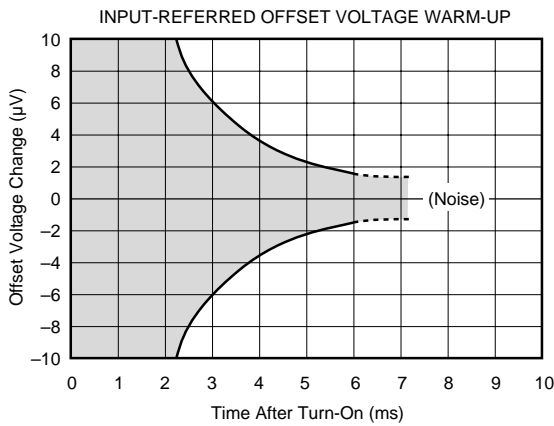
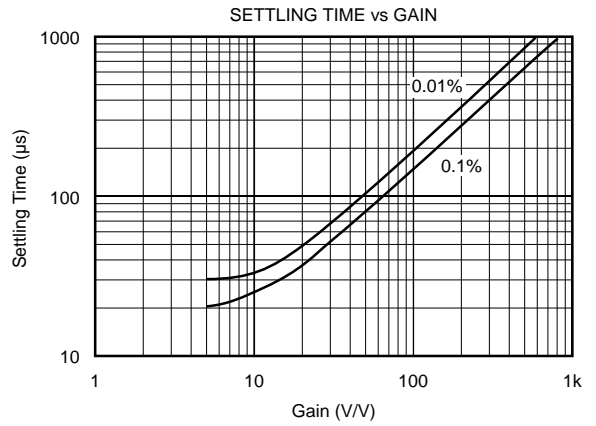
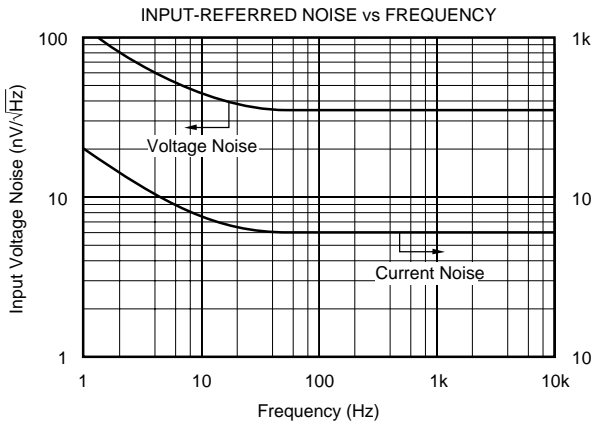

# TYPICAL PERFORMANCE CURVES (CONT)

At  $T_A = +25^\circ\text{C}$  and  $V_S = \pm 15\text{V}$ , unless otherwise noted.

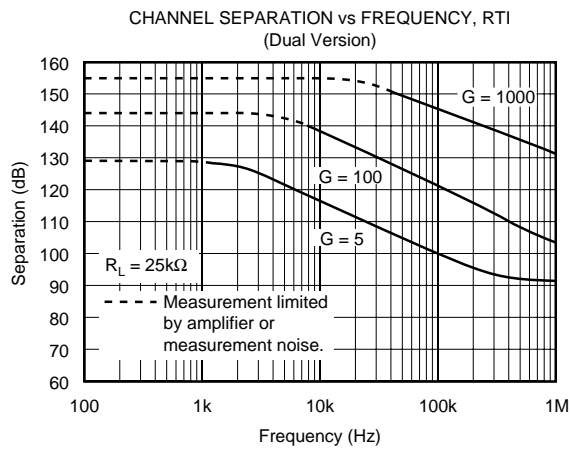
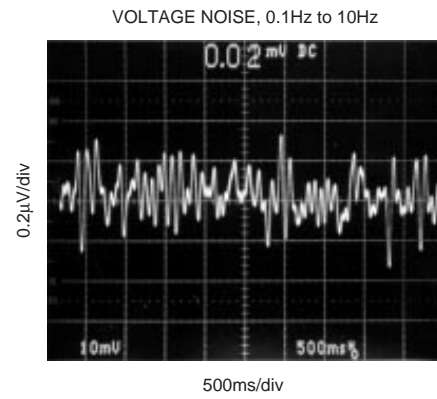
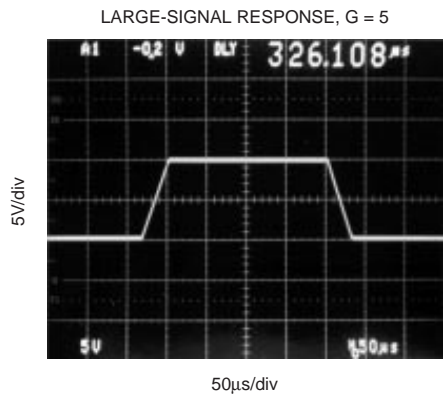
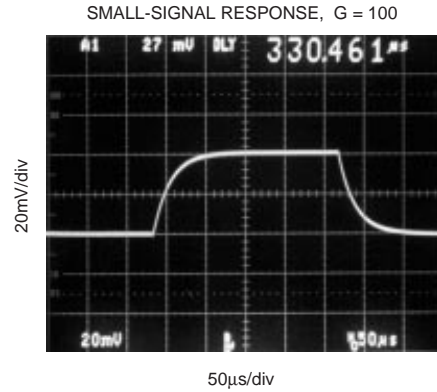
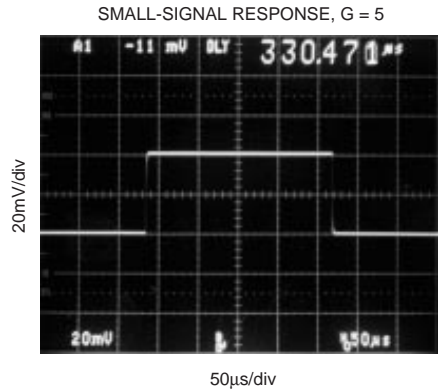

# APPLICATION INFORMATION

Figure 1 shows the basic connections required for operation of the INA126. Applications with noisy or high impedance power supplies may require decoupling capacitors close to the device pins as shown.

The output is referred to the output reference (Ref) terminal which is normally grounded. This must be a low-impedance connection to ensure good common-mode rejection. A resistance of 8Ω in series with the Ref pin will cause a typical device to degrade to approximately 80dB CMR.

Dual versions (INA2126) have feedback sense connections, Sense<sub>A</sub> and Sense<sub>B</sub>. These must be connected to their respective output terminals for proper operation. The sense connection can be used to sense the output voltage directly at the load for best accuracy.

## SETTING THE GAIN

Gain is set by connecting an external resistor, R<sub>G</sub>, as shown:

$$G = 5 + \frac{80k\Omega}{R_G} \quad (1)$$

Commonly used gains and R<sub>G</sub> resistor values are shown in Figure 1.

The 80kΩ term in equation 1 comes from the internal metal film resistors which are laser trimmed to accurate absolute values. The accuracy and temperature coefficient of these resistors are included in the gain accuracy and drift specifications.

The stability and temperature drift of the external gain setting resistor, R<sub>G</sub>, also affects gain. R<sub>G</sub>'s contribution to gain accuracy and drift can be directly inferred from the gain

equation (1). Low resistor values required for high gain can make wiring resistance important. Sockets add to the wiring resistance, which will contribute additional gain error in gains of approximately 100 or greater.

## OFFSET TRIMMING

The INA126 and INA2126 are laser trimmed for low offset voltage and offset voltage drift. Most applications require no external offset adjustment. Figure 2 shows an optional circuit for trimming the output offset voltage. The voltage applied to the Ref terminal is added to the output signal. An op amp buffer is used to provide low impedance at the Ref terminal to preserve good common-mode rejection.

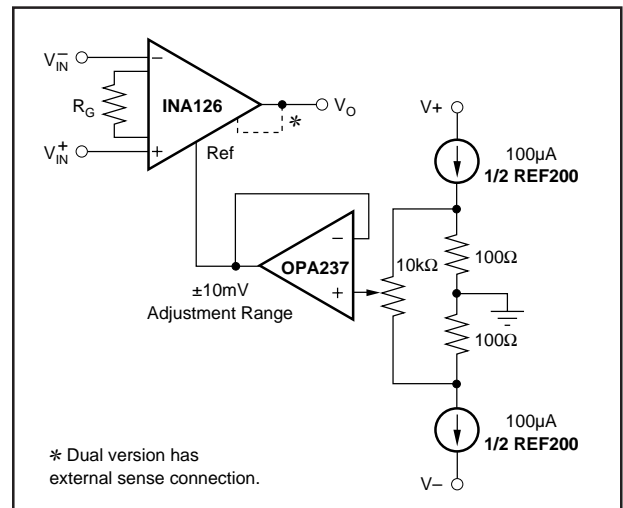

FIGURE 2. Optional Trimming of Output Offset Voltage.

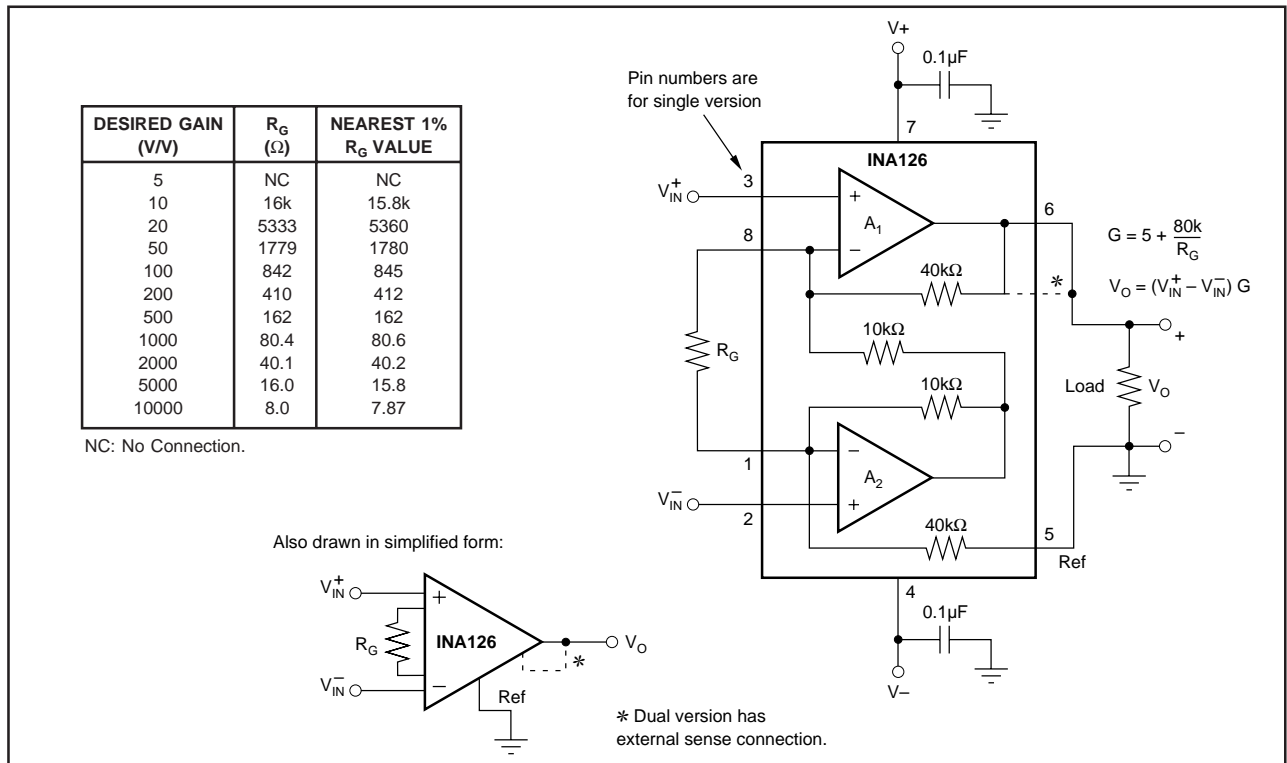

FIGURE 1. Basic Connections.

## INPUT BIAS CURRENT RETURN

The input impedance of the INA126/2126 is extremely high—approximately  $10^9\Omega$ . However, a path must be provided for the input bias current of both inputs. This input bias current is typically  $-10\text{nA}$  (current flows out of the input terminals). High input impedance means that this input bias current changes very little with varying input voltage.

Input circuitry must provide a path for this input bias current for proper operation. Figure 3 shows various provisions for an input bias current path. Without a bias current path, the inputs will float to a potential which exceeds the common-mode range and the input amplifiers will saturate.

If the differential source resistance is low, the bias current return path can be connected to one input (see the thermocouple example in Figure 3). With higher source impedance, using two equal resistors provides a balanced input with advantages of lower input offset voltage due to bias current and better high-frequency common-mode rejection.

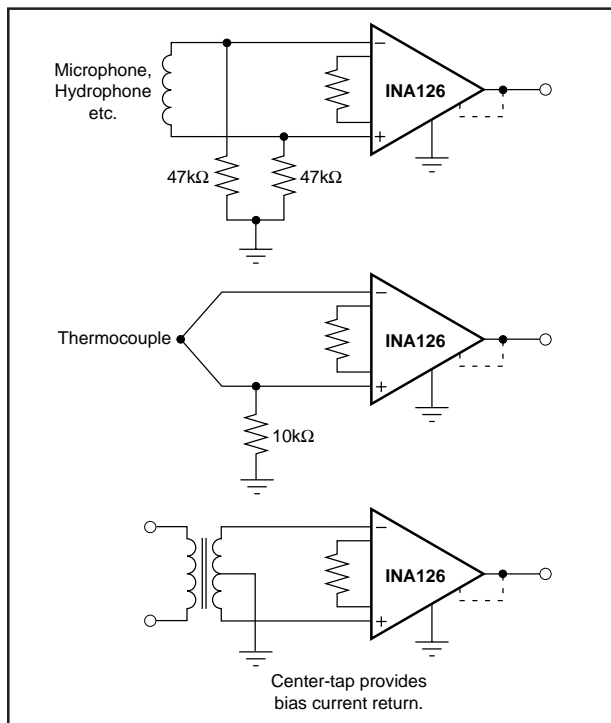

FIGURE 3. Providing an Input Common-Mode Current Path.

## INPUT COMMON-MODE RANGE

The input common-mode range of the INA126/2126 is shown in typical performance curves. The common-mode range is limited on the negative side by the output voltage swing of  $A_2$ , an internal circuit node that cannot be measured on an external pin. The output voltage of  $A_2$  can be expressed as:

$$V_{O2} = 1.25 V_{IN}^- - (V_{IN}^+ - V_{IN}^-) (10\text{k}\Omega/R_G) \quad (2)$$

(Voltages referred to Ref terminal, pin 5)

The internal op amp  $A_2$  is identical to  $A_1$  and its output swing is limited to typically  $0.7\text{V}$  from the supply rails. When the input common-mode range is exceeded ( $A_2$ 's output is saturated),  $A_1$  can still be in linear operation and respond to changes in the non-inverting input voltage. The output voltage, however, will be invalid.

## LOW VOLTAGE OPERATION

The INA126/2126 can be operated on power supplies as low as  $\pm 1.35\text{V}$ . Performance remains excellent with power supplies ranging from  $\pm 1.35\text{V}$  to  $\pm 18\text{V}$ . Most parameters vary only slightly throughout this supply voltage range—see typical performance curves. Operation at very low supply voltage requires careful attention to ensure that the common-mode voltage remains within its linear range. See “Input Common-Mode Voltage Range.”

The INA126/2126 can be operated from a single power supply with careful attention to input common-mode range, output voltage swing of both op amps and the voltage applied to the Ref terminal. Figure 4 shows a bridge amplifier circuit operated from a single  $+5\text{V}$  power supply. The bridge provides an input common-mode voltage near  $2.5\text{V}$ , with a relatively small differential voltage.

## INPUT PROTECTION

The inputs are protected with internal diodes connected to the power supply rails. These diodes will clamp the applied signal to prevent it from exceeding the power supplies by more than approximately  $0.7\text{V}$ . If the signal source voltage can exceed the power supplies, the source current should be limited to less than  $10\text{mA}$ . This can generally be done with a series resistor. Some signal sources are inherently current-limited and do not require limiting resistors.

## CHANNEL CROSSTALK—DUAL VERSION

The two channels of the INA2126 are completely independent, including all bias circuitry. At DC and low frequency there is virtually no signal coupling between channels. Crosstalk increases with frequency and is dependent on circuit gain, source impedance and signal characteristics.

As source impedance increases, careful circuit layout will help achieve lowest channel crosstalk. Most crosstalk is produced by capacitive coupling of signals from one channel to the input section of the other channel. To minimize coupling, separate the input traces as far as practical from any signals associated with the opposite channel. A grounded guard trace surrounding the inputs helps reduce stray coupling between channels. Carefully balance the stray capacitance of each input to ground, and run the differential inputs of each channel parallel to each other, or directly adjacent on top and bottom side of a circuit board. Stray coupling then tends to produce a common-mode signal that is rejected by the IA's input.

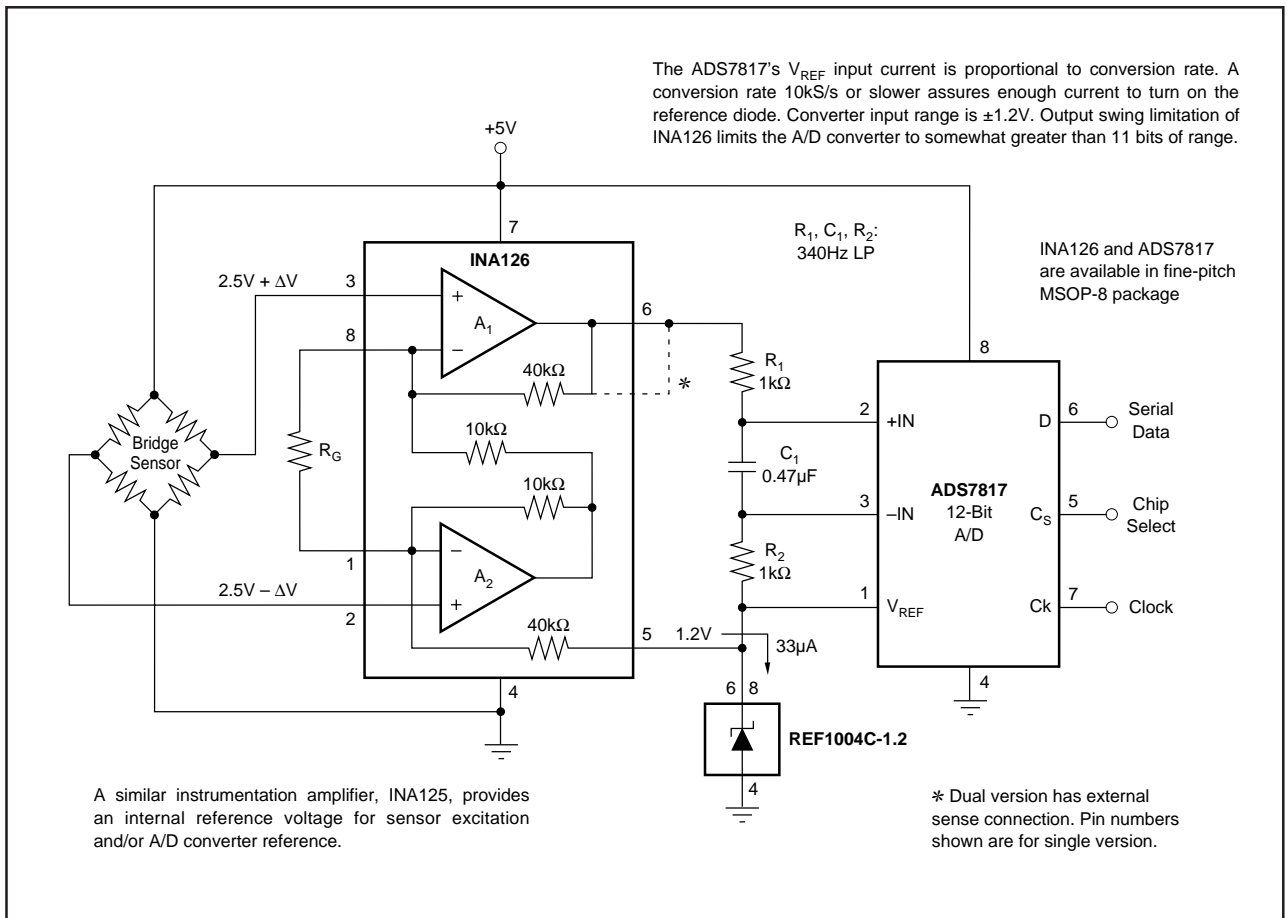

FIGURE 4. Bridge Signal Acquisition—Single 5V Supply.

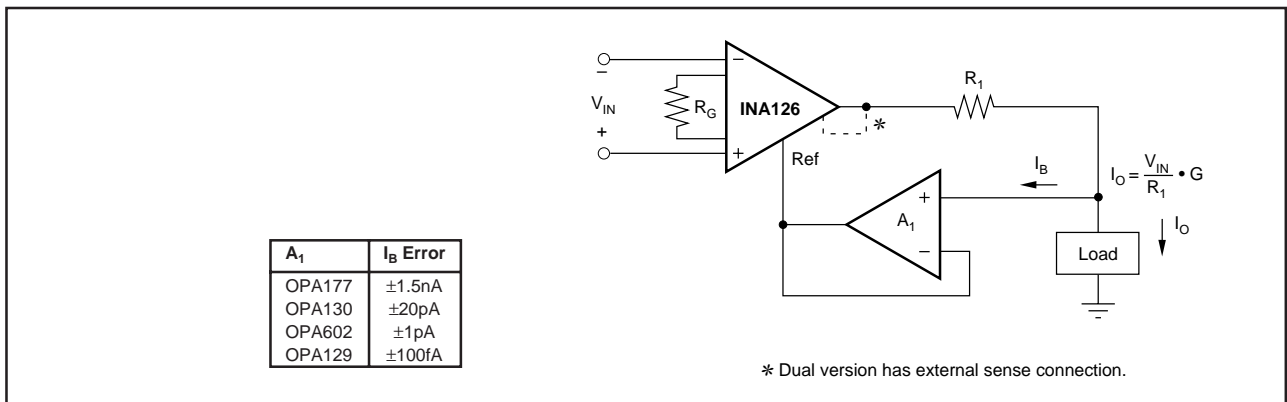

FIGURE 5. Differential Voltage-to-Current Converter.

This datasheet has been downloaded from:

[www.DatasheetCatalog.com](http://www.DatasheetCatalog.com)

Datasheets for electronic components.



LittleDiode supplies new, hard to find or obsolete electronic components and semiconductors all over the world.

With over two million different components listed you are sure to find the part you need.

Feel free to visit us today at our online store:

[LittleDiode.com](http://LittleDiode.com)

Looking forward to providing you with the best possible service.