



For most current data sheet and other product information, visit [www.burr-brown.com](http://www.burr-brown.com)

## Programmable Gain DIFFERENCE AMPLIFIER

### FEATURES

- DIFFERENTIAL GAIN = 1V/V TO 1000V/V:  
Set with External Resistors
- LOW QUIESCENT CURRENT: 570µA
- WIDE SUPPLY RANGE:  
Single Supply: 4.5V to 36V  
Dual Supplies: ±2.25V to ±18V
- HIGH COMMON-MODE VOLTAGE:  
+8V at  $V_S = +5V$   
±28V at  $V_S = ±15V$
- LOW GAIN ERROR: 0.01%
- HIGH CMR: 86dB
- SO-8 PACKAGE

### DESCRIPTION

The INA145 is a precision, unity-gain difference amplifier consisting of a precision op amp and on-chip precision resistor network. Two external resistors set the gain from 1V/V to 1000V/V. The input common-mode voltage range extends beyond the positive and negative rails.

On-chip precision resistors are laser-trimmed to achieve accurate gain and high common-mode rejection. Excellent TCR tracking of these resistors assures continued high precision over temperature.

The INA145 is available in the SO-8 surface-mount package specified for the extended industrial temperature range, -40°C to +85°C.

### APPLICATIONS

- CURRENT SHUNT MEASUREMENTS
- SENSOR AMPLIFIER
- DIFFERENTIAL LINE RECEIVER
- BATTERY POWERED SYSTEMS

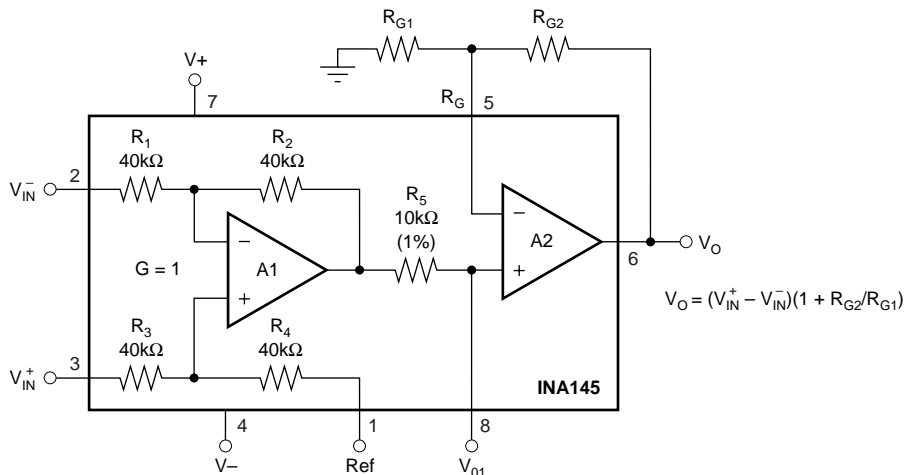

# SPECIFICATIONS: $V_S = \pm 2.25V$ to $\pm 18V$

**Boldface** limits apply over the specified temperature range,  $T_A = -40^\circ C$  to  $+85^\circ C$

At  $T_A = +25^\circ C$ ,  $G = 1$ ,  $R_L = 10k\Omega$  connected to ground and ref pin connected to ground unless otherwise noted.

PARAMETER	CONDITION	INA145UA			UNITS	
		MIN	TYP	MAX		
<b>OFFSET VOLTAGE, <math>V_O</math></b> Input Offset Voltage <b>vs Temperature</b> <b>vs Power Supply</b> <b>vs Time</b> Offset Voltage, $V_{O1}$	RTI <sup>(1, 2)</sup> $V_{CM} = V_O = 0V$		$\pm 0.2$	$\pm 1$	mV	
		<b>See Typical Curve</b>				
	PSRR	$V_S = \pm 1.35V$ to $\pm 18V$		$\pm 20$	$\pm 60$	$\mu V/V$
				$\pm 0.3$		$\mu V/mo$
	RTI <sup>(1, 2)</sup>		$\pm 0.4$		mV	
<b>INPUT VOLTAGE RANGE</b> Common-Mode Voltage Range Common-Mode Rejection <b>Over Temperature</b>	$(V_{IN+}) - (V_{IN-}) = 0V$ , $V_O = 0V$ $V_{CM} = 2(V-) to 2(V+) - 2V$ , $R_S = 0\Omega$ $V_S = \pm 15V$	2(V-)		2(V+) - 2	V	
		76	86		dB	
		<b>70</b>	<b>80</b>		dB	
<b>INPUT BIAS CURRENT<sup>(2)</sup></b> Bias Current Offset Current	$V_{CM} = V_S/2$		$\pm 50$		nA	
			$\pm 5$		nA	
<b>INPUT IMPEDANCE</b> Differential (non-inverting input) Differential (inverting input) Common-Mode			80		k $\Omega$	
			27		k $\Omega$	
			40		k $\Omega$	
<b>NOISE</b> Voltage Noise, $f = 0.1Hz$ to $10Hz$ Voltage Noise Density, $f = 1kHz$	RTI <sup>(1, 3)</sup>		2		$\mu Vp-p$	
			90		$nV/\sqrt{Hz}$	
<b>GAIN</b> Gain Equation Initial <sup>(1)</sup> Gain Error <b>vs Temperature</b>  <b>vs Temperature</b> Nonlinearity	$R_L = 100k\Omega$ , $V_O = (V-)+0.15$ to $(V+)-1$ , $G = 1$ <b><math>R_L = 100k\Omega</math>, <math>V_O = (V-)+0.25</math> to <math>(V+)-1</math>, <math>G = 1</math></b> $R_L = 10k\Omega$ , $V_O = (V-)+0.3$ to $(V+)-1.25$ , $G = 1$ <b><math>R_L = 10k\Omega</math>, <math>V_O = (V-)+0.5</math> to <math>(V+)-1.25</math>, <math>G = 1</math></b> $R_L = 10k\Omega$ , $V_O = (V-)+0.3$ to $(V+)-1.25$ , $G = 1$		$G = 1$ to $1000$ $G = 1 + R_{G2}/R_{G1}$		V/V	
			1		V/V	
			$\pm 0.01$	$\pm 0.1$	%	
			$\pm 2$	$\pm 10$	ppm/ $^\circ C$	
			$\pm 0.01$	$\pm 0.1$	%	
	$\pm 2$	$\pm 10$	ppm/ $^\circ C$			
		$\pm 0.0002$	$\pm 0.005$	% of FS		
<b>FREQUENCY RESPONSE</b> Small Signal Bandwidth  Slew Rate Settling Time, 0.1% 0.01% Overload Recovery	$G = 1$ $G = 10$  $G = 1$ , 10V Step $G = 1$ , 10V Step 50% Input Overload		500		kHz	
			50		kHz	
			0.45		V/ $\mu s$	
			40		$\mu s$	
			90		$\mu s$	
			40		$\mu s$	
<b>OUTPUT, <math>V_O</math></b> Voltage Output <b>Over Temperature</b>  <b>Over Temperature</b> Short-Circuit Current Capacitive Load	$R_L = 100k\Omega$ , $G = 1$ <b><math>R_L = 100k\Omega</math>, <math>G = 1</math></b> $R_L = 10k\Omega$ , $G = 1$ <b><math>R_L = 10k\Omega</math>, <math>G = 1</math></b> Continuous to Common Stable Operation	(V-) + 0.15		(V+) - 1	V	
		<b>(V-) + 0.25</b>		<b>(V+) - 1</b>	V	
		(V-) + 0.3		(V+) - 1.25	V	
		<b>(V-) + 0.5</b>		<b>(V+) - 1.25</b>	V	
			$\pm 15$		mA	
	1000		pF			
<b>POWER SUPPLY</b> Specified Voltage Range, Dual Supplies Operating Voltage Range Quiescent Current <b>Over Temperature</b>	$V_{IN} = 0$ , $I_O = 0$	$\pm 2.25$		$\pm 18$	V	
		$\pm 1.35$		$\pm 18$	V	
			$\pm 570$	$\pm 700$	$\mu A$	
				<b><math>\pm 800</math></b>	$\mu A$	
<b>TEMPERATURE RANGE</b> Specified Range Operating Range Storage Range Thermal Resistance	$\theta_{JA}$	-40		+85	$^\circ C$	
		-55		+125	$^\circ C$	
		-55		+125	$^\circ C$	
			150		$^\circ C/W$	

NOTES: (1) Referred to input pins ( $V_{IN+}$  and  $V_{IN-}$ ), Gain = 1V/V. Specified with 10k $\Omega$  in feedback of A2. (2) Input offset voltage specification includes effects of amplifier's input bias and offset currents. (3) Includes effects of input bias current noise and thermal noise contribution of resistor network.

The information provided herein is believed to be reliable; however, BURR-BROWN assumes no responsibility for inaccuracies or omissions. BURR-BROWN assumes no responsibility for the use of this information, and all use of such information shall be entirely at the user's own risk. Prices and specifications are subject to change without notice. No patent rights or licenses to any of the circuits described herein are implied or granted to any third party. BURR-BROWN does not authorize or warrant any BURR-BROWN product for use in life support devices and/or systems.

# SPECIFICATIONS: $V_S = +5V$ Single Supply

**Boldface** limits apply over the specified temperature range,  $T_A = -40^\circ\text{C}$  to  $+85^\circ\text{C}$

At  $T_A = +25^\circ\text{C}$ ,  $G = 1$ ,  $R_L = 10\text{k}\Omega$  connected to ground and ref pin connected to 2.5V unless otherwise noted.

PARAMETER	CONDITION	INA145UA			UNITS
		MIN	TYP	MAX	
<b>OFFSET VOLTAGE, <math>V_O</math></b> Input Offset Voltage $V_{OS}$ <b>vs Temperature</b> $\Delta V_{OS}/\Delta T$ vs Power Supply Rejection Ratio PSRR vs Time Offset Voltage, $V_{O1}$	RTI <sup>(1, 2)</sup> $V_{CM} = V_O = 2.5V$		$\pm 0.35$	$\pm 1$	mV
	$V_S = \pm 1.35V$ to $\pm 18V$		<b>See Typical Curve</b>		$\mu\text{V}/^\circ\text{C}$
	RTI <sup>(1, 2)</sup>		$\pm 20$	$\pm 60$	$\mu\text{V}/\text{mo}$
			$\pm 0.3$		mV
		$\pm 0.55$			
<b>INPUT VOLTAGE RANGE</b> Common-Mode Voltage Range <sup>(3)</sup> $V_{CM}$ Common-Mode Rejection Ratio CMRR <b>Over Temperature</b>	$V_{IN+} - V_{IN-} = 0V$ , $V_O = 2.5V$ $V_{CM} = -2.5V$ to $+5.5V$ , $R_S = 0\Omega$	-2.5		5.5	V
		76	86 <b>80</b>		dB dB
<b>INPUT BIAS CURRENT<sup>(2)</sup></b> Bias Current $I_B$ Offset Current $I_{OS}$			$\pm 50$		nA
			$\pm 5$		nA
<b>INPUT IMPEDANCE</b> Differential (non-inverting input) Differential (inverting input) Common-Mode			80		k $\Omega$
			27		k $\Omega$
			40		k $\Omega$
<b>NOISE</b> Voltage Noise, $f = 0.1\text{Hz}$ to $10\text{Hz}$ Voltage Noise Density, $f = 1\text{kHz}$ $e_n$	RTI <sup>(1, 4)</sup>		2		$\mu\text{Vp-p}$
			90		$\text{nV}/\sqrt{\text{Hz}}$
<b>GAIN</b> Gain Equation Initial <sup>(1)</sup> Gain Error <b>vs Temperature</b>  <b>vs Temperature</b> Nonlinearity			$G = 1$ to $1000$ $G = 1 + R_{G2}/R_{G1}$		V/V V/V V/V
	$R_L = 100\text{k}\Omega$ , $V_O = 0.15V$ to $4V$ , $G = 1$		1		%
	<b><math>R_L = 100\text{k}\Omega</math>, <math>V_O = 0.25V</math> to <math>4V</math>, <math>G = 1</math></b>		$\pm 0.01$	$\pm 0.1$	ppm/ $^\circ\text{C}$
	$R_L = 10\text{k}\Omega$ , $V_O = 0.3V$ to $3.75V$ , $G = 1$		$\pm 0.01$	$\pm 0.1$	%
	<b><math>R_L = 10\text{k}\Omega</math>, <math>V_O = 0.5V</math> to <math>3.75V</math>, <math>G = 1</math></b>		$\pm 2$	$\pm 10$	ppm/ $^\circ\text{C}$
	$R_L = 10\text{k}\Omega$ , $V_O = +0.3$ to $+3.75$ , $G = 1$		$\pm 0.001$	$\pm 0.005$	% of FS
<b>FREQUENCY RESPONSE</b> Small Signal Bandwidth  Slew Rate Settling Time, 0.1% 0.01% Overload Recovery	$G = 0.1$ $G = 1$		500 50		kHz kHz
	$G = 1$ , 10V Step		0.45		V/ $\mu\text{s}$
	$G = 1$ , 10V Step		40		$\mu\text{s}$
	90		90		$\mu\text{s}$
	50% Input Overload		40		$\mu\text{s}$
<b>OUTPUT, <math>V_O</math></b> Voltage Output <b>Over Temperature</b>  <b>Over Temperature</b> Short-Circuit Current Capacitive Load	$R_L = 100\text{k}\Omega$ , $G = 1$	0.15		4	V
	<b><math>R_L = 100\text{k}\Omega</math>, <math>G = 1</math></b>	<b>0.25</b>		<b>4</b>	V
	$R_L = 10\text{k}\Omega$ , $G = 1$	0.3		3.75	V
	<b><math>R_L = 10\text{k}\Omega</math>, <math>G = 1</math></b>	<b>0.5</b>		<b>3.75</b>	V
	Continuous to Common Stable Operation		$\pm 15$		mA
			1000		pF
<b>POWER SUPPLY</b> Specified Voltage Range, Single Supply Operating Voltage Range Quiescent Current <b>Over Temperature</b>	$V_{IN} = 0$ , $I_O = 0$	+4.5 +2.7		+36 +36	V V
			550	700	$\mu\text{A}$
				<b>800</b>	$\mu\text{A}$
<b>TEMPERATURE RANGE</b> Specified Range Operating Range Storage Range Thermal Resistance $\theta_{JA}$		-40		+85	$^\circ\text{C}$
		-55		+125	$^\circ\text{C}$
		-55		+125	$^\circ\text{C}$
			150		$^\circ\text{C}/W$

NOTES: (1) Referred to input pins ( $V_{IN+}$  and  $V_{IN-}$ ), Gain = 1V/V. Specified with 10k $\Omega$  in feedback of A2. (2) Input offset voltage specification includes effects of amplifier's input bias and offset currents. (3) Common-mode voltage range with single supply is  $2(V+) - 2V - V_{REF}$  to  $-V_{REF}$ . (4) Includes effects of input current noise and thermal noise contribution of resistor network.

# AMPLIFIER A1, A2 PERFORMANCE

**Boldface** limits apply over the specified temperature range,  $T_A = -40^{\circ}\text{C}$  to  $+85^{\circ}\text{C}$

At  $T_A = +25^{\circ}\text{C}$ ,  $G = 1$ ,  $R_L = 10\text{k}\Omega$  connected to ground and ref pin connected to ground unless otherwise noted.

PARAMETER	CONDITION	INA145UA			UNITS
		MIN	TYP	MAX	
<b>OFFSET VOLTAGE, <math>V_O</math></b> Input Offset Voltage <b>vs Temperature</b>	RTI <sup>(1,2)</sup> $V_S = \pm 15\text{V}$ , $V_{CM} = V_O = 0\text{V}$		$\pm 0.5$ $\pm 1$		mV $\mu\text{V}/^{\circ}\text{C}$
<b>INPUT VOLTAGE RANGE</b> Common-Mode Voltage Range Common-Mode Rejection Ratio	$V_{IN+} - V_{IN-} = 0\text{V}$ , $V_O = 0\text{V}$ $V_{CM} = (V-) \text{ to } (V+) - 1$		(V-) to (V+) - 1 90		V dB
<b>OPEN-LOOP GAIN</b> Open Loop Gain			110		dB
<b>INPUT BIAS CURRENT<sup>(2)</sup></b> Bias Current Offset Current			$\pm 50$ $\pm 5$		nA nA
<b>RESISTOR AT A1 OUTPUT, <math>V_{O1}</math></b> Initial Error Temperature Drift Coefficient			10 $\pm 0.2$ $\pm 50$		k $\Omega$ % ppm/ $^{\circ}\text{C}$

## PIN CONFIGURATION

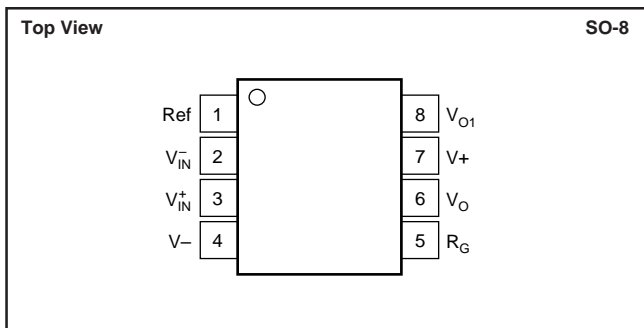

## ELECTROSTATIC DISCHARGE SENSITIVITY

This integrated circuit can be damaged by ESD. Burr-Brown recommends that all integrated circuits be handled with appropriate precautions. Failure to observe proper handling and installation procedures can cause damage.

ESD damage can range from subtle performance degradation to complete device failure. Precision integrated circuits may be more susceptible to damage because very small parametric changes could cause the device not to meet its published specifications.

## ABSOLUTE MAXIMUM RATINGS<sup>(1)</sup>

Supply Voltage, $V+$ to $V-$	36V
Signal Input Terminals, Voltage	$\pm 80\text{V}$
Current	$\pm 1\text{mA}$
Output Short Circuit (to ground)	Continuous
Operating Temperature	$-55^{\circ}\text{C}$ to $+125^{\circ}\text{C}$
Storage Temperature	$-55^{\circ}\text{C}$ to $+150^{\circ}\text{C}$
Junction Temperature	$+150^{\circ}\text{C}$
Lead Temperature (soldering, 10s)	$+240^{\circ}\text{C}$

NOTE: (1) Stresses above these ratings may cause permanent damage. Exposure to absolute maximum conditions for extended periods may degrade device reliability.

## PACKAGE/ORDERING INFORMATION

PRODUCT	PACKAGE	PACKAGE DRAWING NUMBER	SPECIFIED TEMPERATURE RANGE	PACKAGE MARKING	ORDERING NUMBER <sup>(1)</sup>	TRANSPORT MEDIA
INA145UA "	SO-8 "	182 "	$-40^{\circ}\text{C}$ to $+85^{\circ}\text{C}$ "	INA145UA "	INA145UA INA145UA/2K5	Rails Tape and Reel

NOTE: (1) Models with a slash (/) are available only in Tape and Reel in the quantities indicated (e.g., /2K5 indicates 2500 devices per reel). Ordering 2500 pieces of "INA145UA/2K5" will get a single 2500-piece Tape and Reel.

# TYPICAL PERFORMANCE CURVES

At  $T_A = +25^\circ\text{C}$ ,  $V_S = \pm 15\text{V}$ ,  $G = 1$ ,  $R_L = 10\text{k}\Omega$  connected to ground and Ref pin connected to ground, unless otherwise noted.

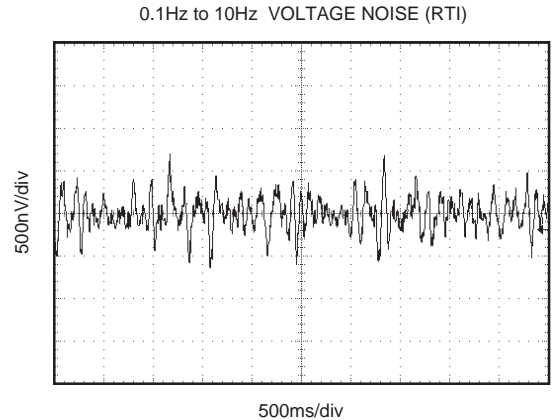
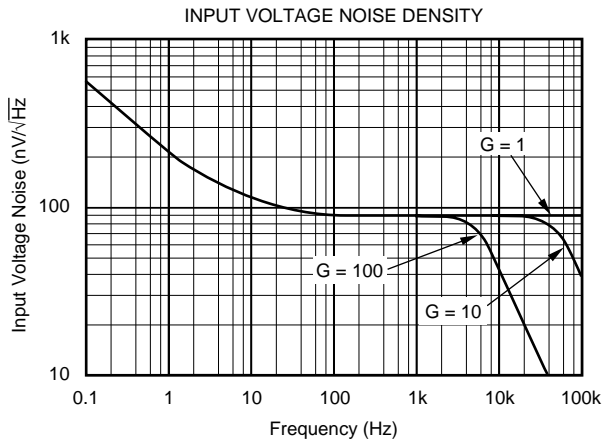
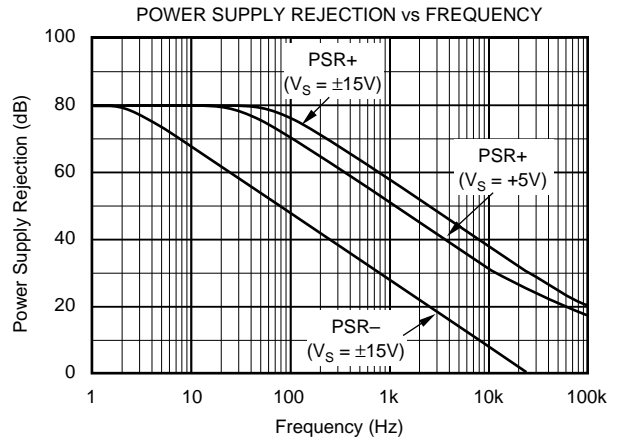
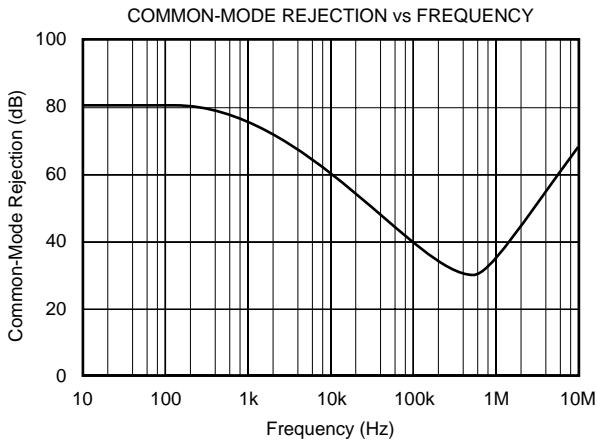
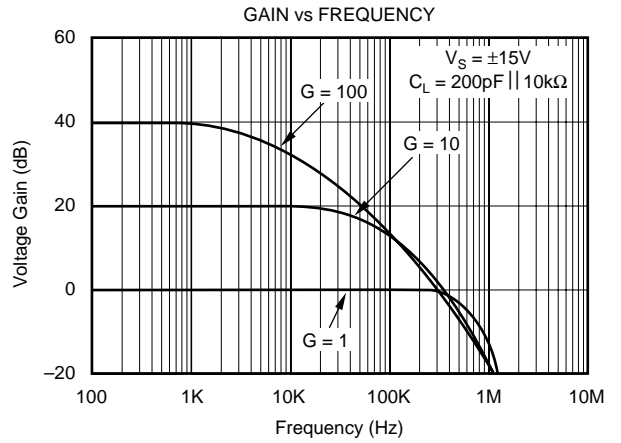
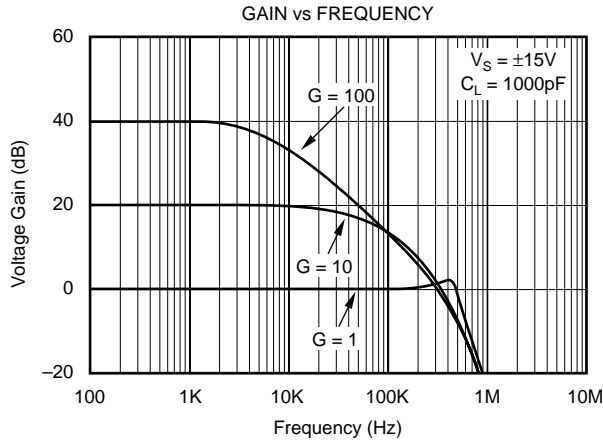

# TYPICAL PERFORMANCE CURVES (Cont.)

At  $T_A = +25^\circ\text{C}$ ,  $V_S = \pm 15\text{V}$ ,  $G = 1$ ,  $R_L = 10\text{k}\Omega$  connected to ground and Ref pin connected to ground, unless otherwise noted.

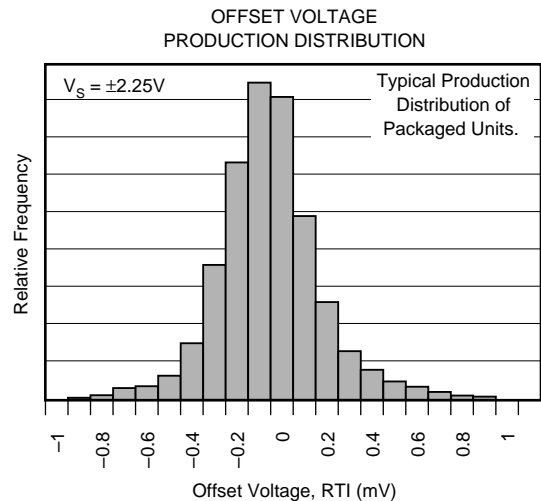
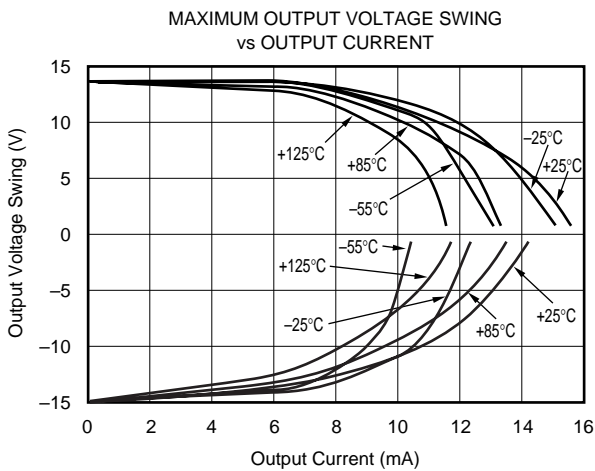
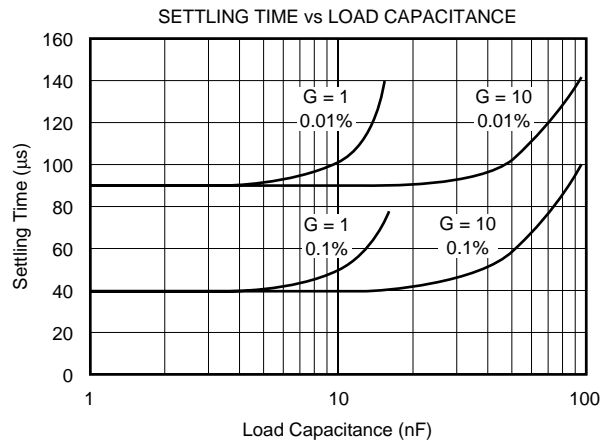
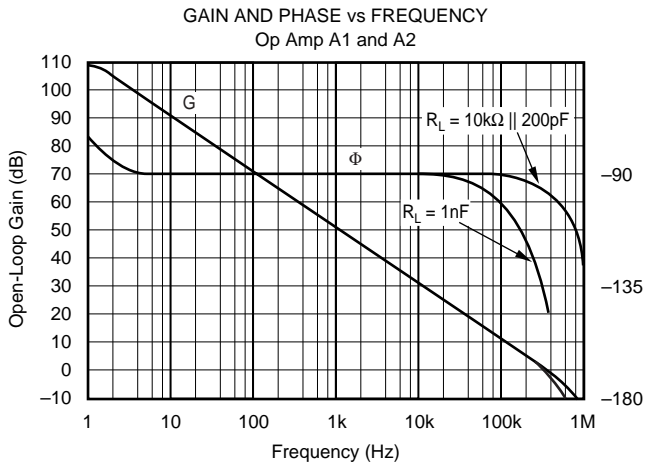
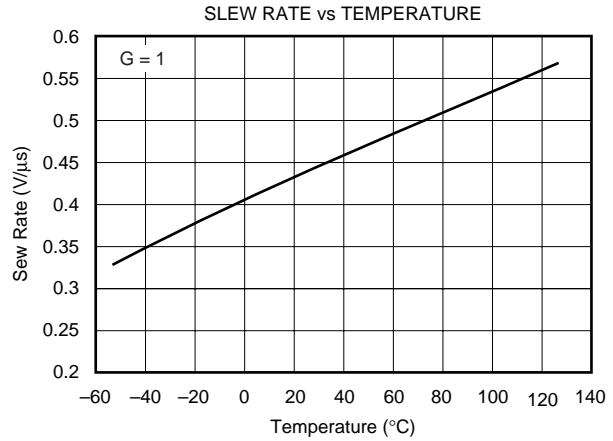
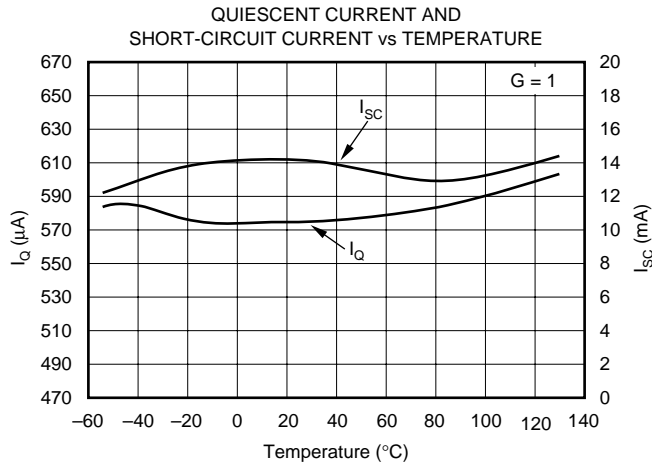

# TYPICAL PERFORMANCE CURVES (Cont.)

At  $T_A = +25^\circ\text{C}$ ,  $V_S = \pm 15\text{V}$ ,  $G = 1$ ,  $R_L = 10\text{k}\Omega$  connected to ground and Ref pin connected to ground, unless otherwise noted.

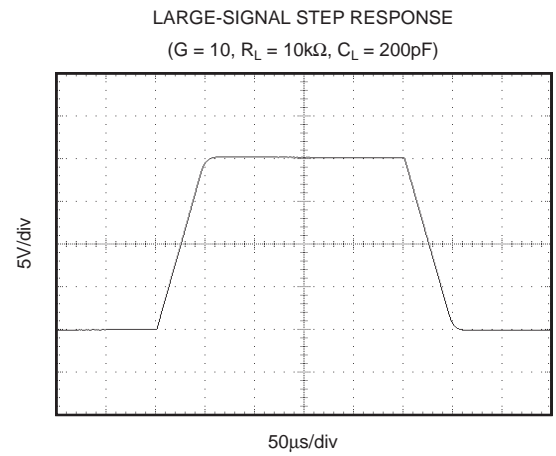
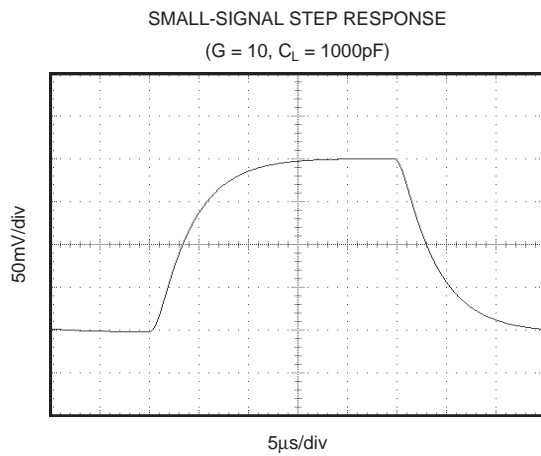
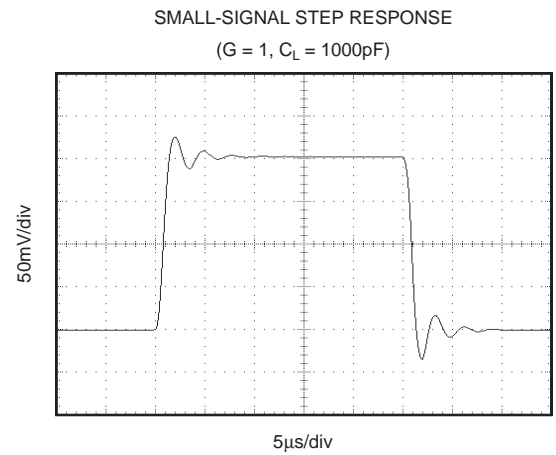
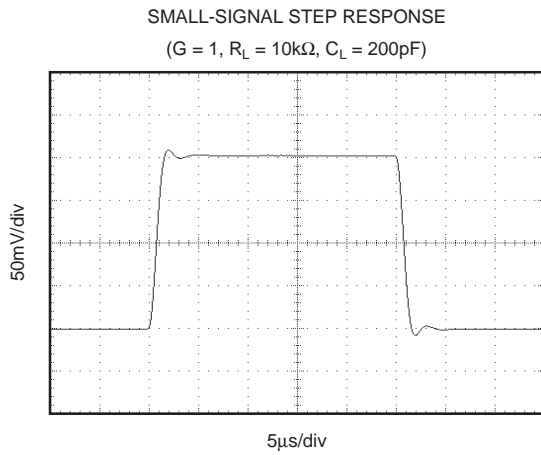
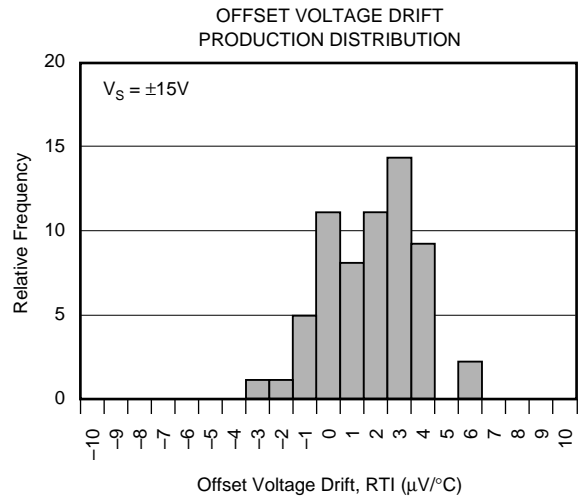
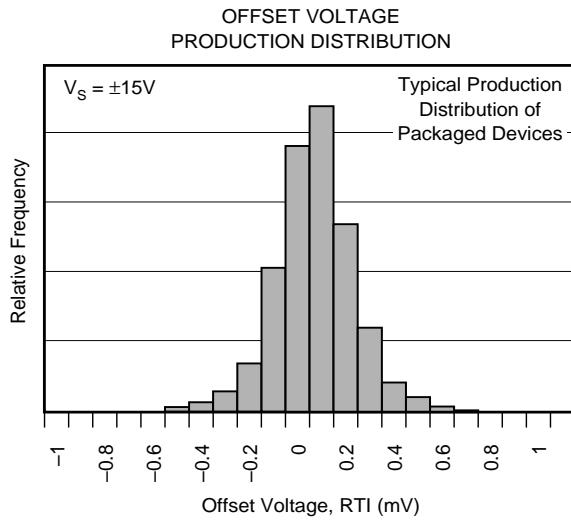

# APPLICATION INFORMATION

The INA145 is a programmable gain difference amplifier consisting of a gain of 1 difference amplifier and a programmable-gain output buffer stage. Basic circuit connections are shown in Figure 1. Power supply bypass capacitors should be connected close to pins 4 and 7, as shown. The amplifier is programmable in the range of  $G = 1$  to  $G = 1000$  with two external resistors.

The output of A1 is connected to the noninverting input of A2 through a  $10\text{k}\Omega$  resistor which is trimmed to  $\pm 1\%$  absolute accuracy. The A2 input is available for applications such as a filter or a precision current source. See application figures for examples.

## OPERATING VOLTAGE

The INA145 is fully specified for supply voltages from  $\pm 2.25\text{V}$  to  $\pm 18\text{V}$ , with key parameters guaranteed over the temperature range  $-40^\circ\text{C}$  to  $+85^\circ\text{C}$ . The INA145 can be operated with single or dual supplies, with excellent performance. Parameters that vary significantly with operating voltage, load conditions, or temperature are shown in the typical performance curves.

## SETTING THE GAIN

The gain of the INA145 is set by using two external resistors,  $R_{G1}$  and  $R_{G2}$ , according to the equation:

$$G = 1 + R_{G2}/R_{G1}$$

For a total gain of 1, A2 is connected as a buffer amplifier with no  $R_{G1}$ . A feedback resistor,  $R_{G2} = 10\text{k}\Omega$ , should be used in the buffer connection. This provides bias current cancellation (in combination with internal  $R_5$ ) to assure specified offset voltage performance. Commonly used values are shown in the table of Figure 1. Resistor values for other gains should be chosen to provide a  $10\text{k}\Omega$  parallel resistance.

## COMMON-MODE RANGE

The input resistors of the INA145 provides an input common-mode range that extends well beyond the power supply rails. Exact range depends on the power supply voltage and the voltage applied to the Ref terminal (pin 1). To assure proper operation, the voltage at the non-inverting input of A1 (an internal node) must be within its linear operating range. Its voltage is determined by the simple 1:1 voltage divider between pin 3 and pin 1. This voltage must be between  $V_-$  and  $(V_+) - 1\text{V}$ .

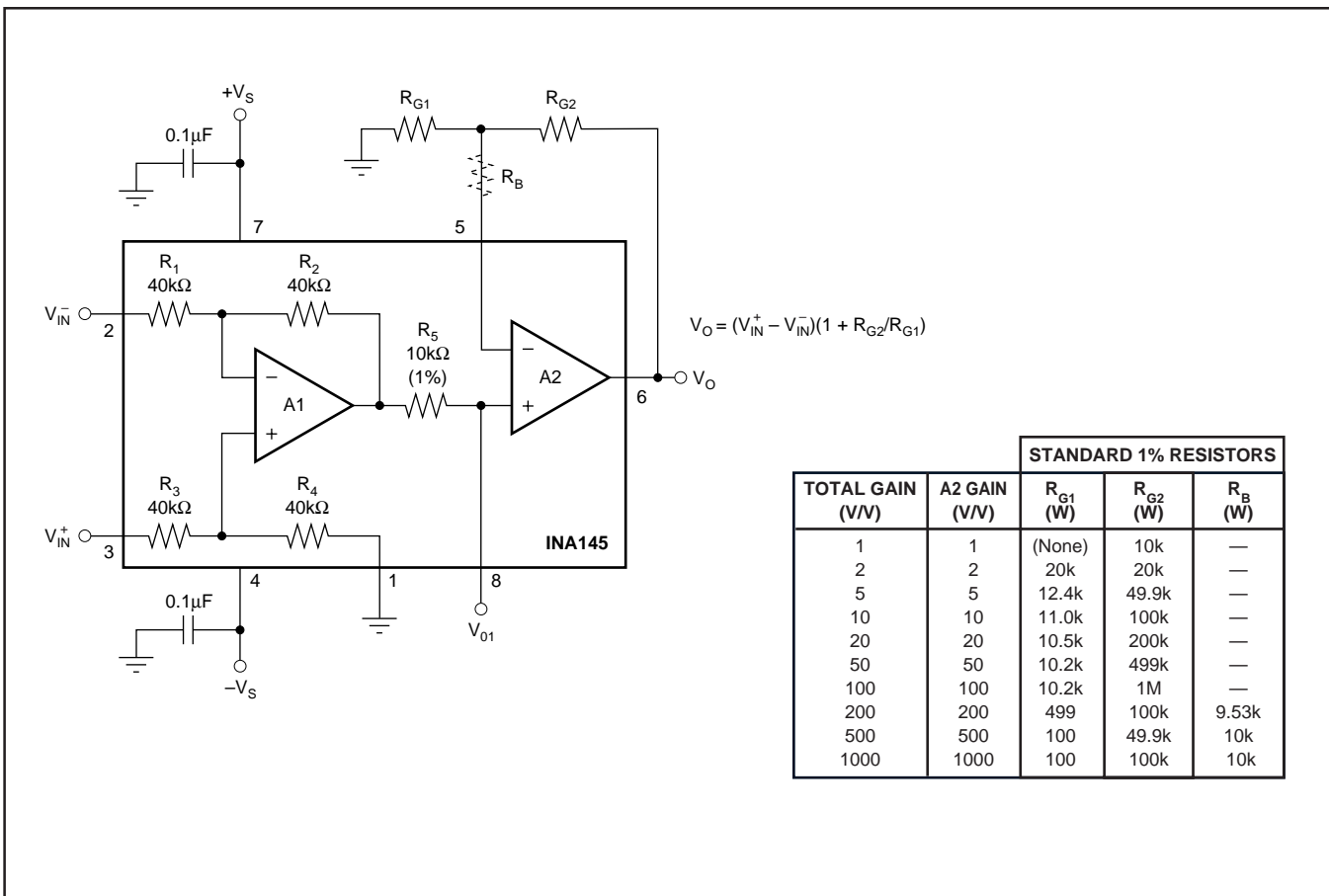

FIGURE 1. Basic Circuit Connections.

## OFFSET TRIM

The INA145 is laser-trimmed for low offset voltage and drift. Most applications require no external offset adjustment. Figure 2 shows an optional circuit for trimming the offset voltage. A voltage applied to the Ref terminal will be summed with the output signal. This can be used to null offset voltage. To maintain good common-mode rejection, the source impedance of a signal applied to the Ref terminal should be less than  $10\Omega$  and a resistor added to the positive input terminal should be 10 times that, or  $100\Omega$ . Alternatively, the trim voltage can be buffered with an op amp such as the OPA277.

## INPUT IMPEDANCE

The input impedance of the INA145 is determined by the input resistor network and is approximately  $40k\Omega$ . The source impedance at the two input terminals must be nearly equal to maintain good common-mode rejection. A  $5\Omega$  mismatch in impedance between the two inputs will cause the typical common-mode rejection to be degraded to approximately  $72\text{dB}$ . Figure 7 shows a common application measuring power supply current through a shunt resistor. The source impedance of the shunt resistor,  $R_S$ , is balanced by an equal compensation resistor,  $R_C$ .

Source impedances greater than  $300\Omega$  are not recommended, even if they are perfectly matched. Internal resistors are laser trimmed for accurate ratios, not to absolute values. Adding equal resistors greater than  $300\Omega$  can cause a mismatch in the total resistor ratios, degrading CMR.

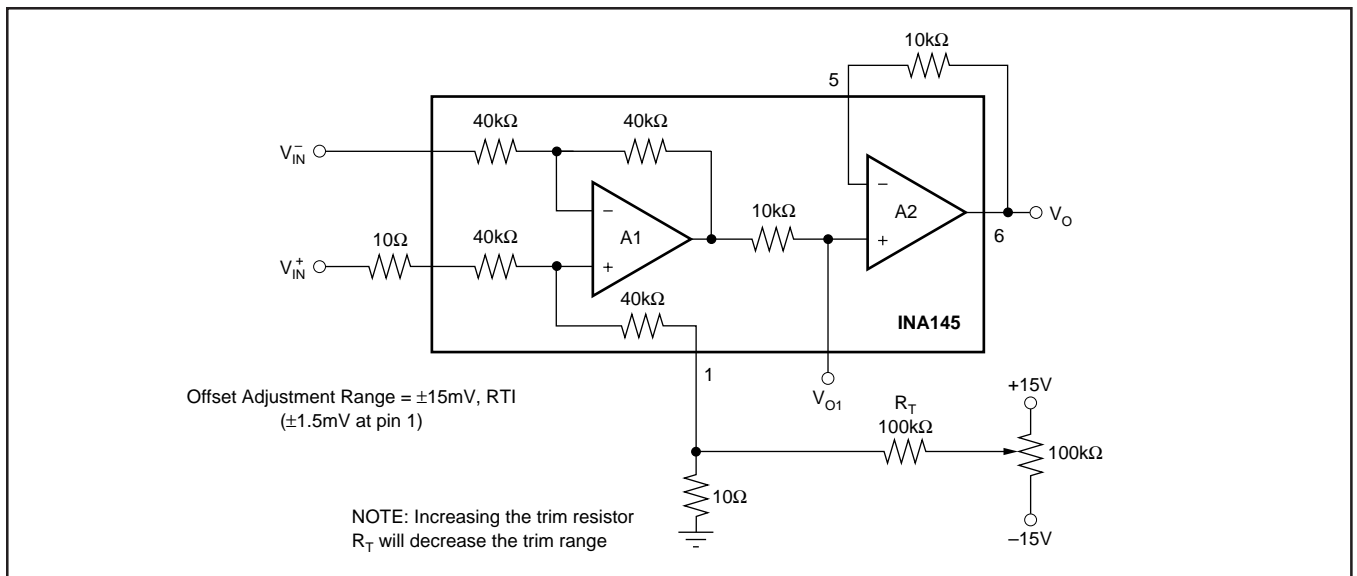

FIGURE 2. Optional Offset Trim Circuit.

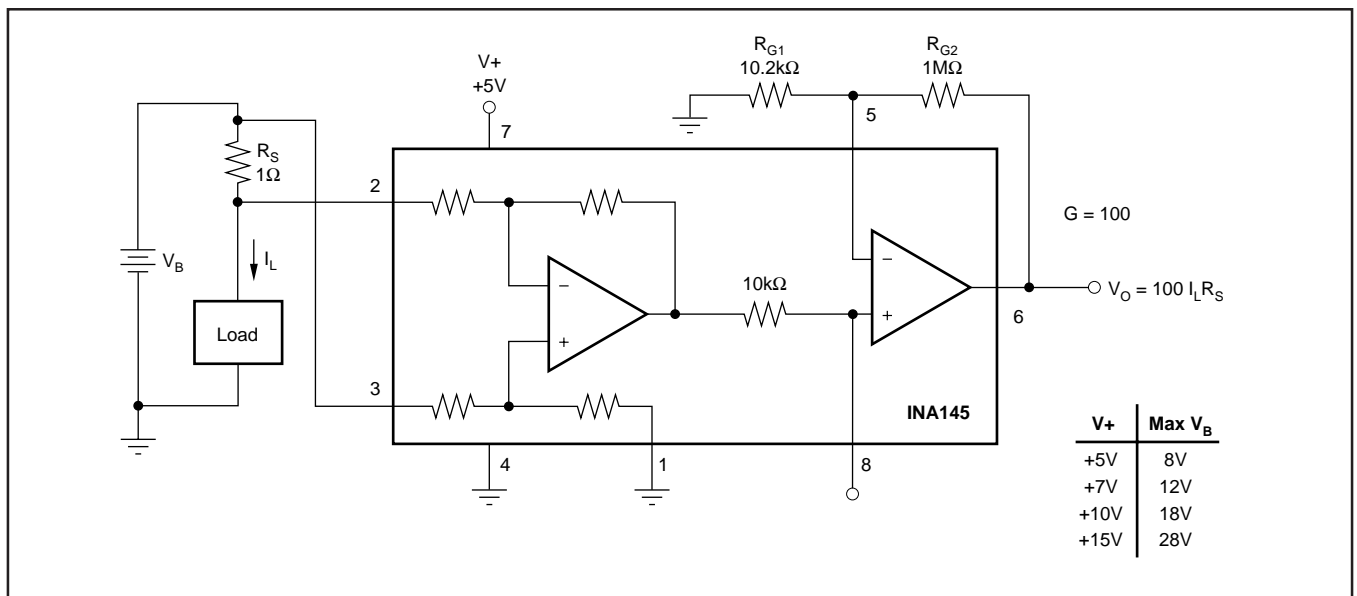

FIGURE 3. Measuring Current with Shunt Resistor.

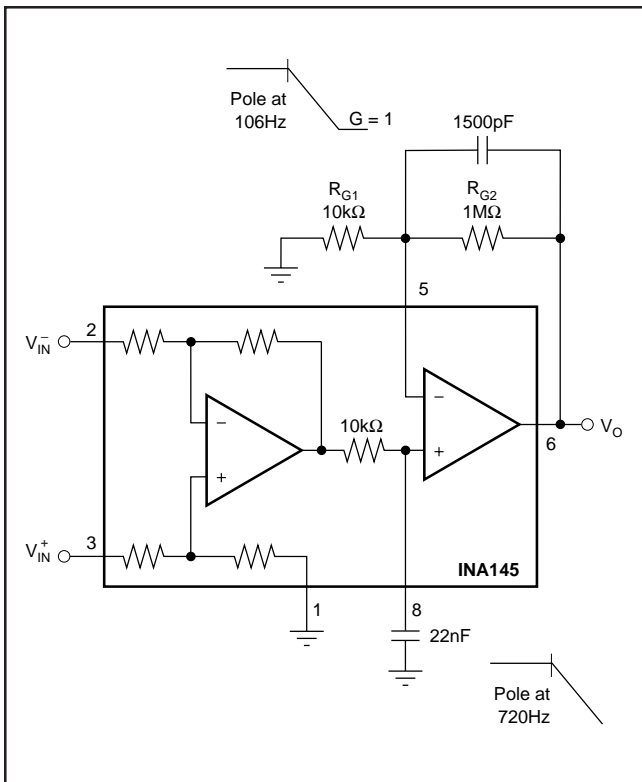

FIGURE 4. Noise Filtering.

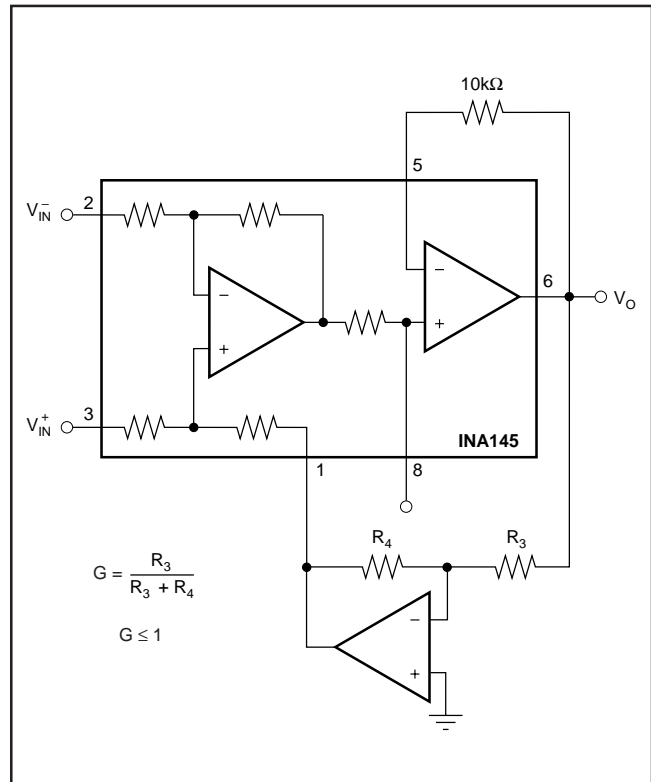

FIGURE 5. Creating Gains Less Than Unity.

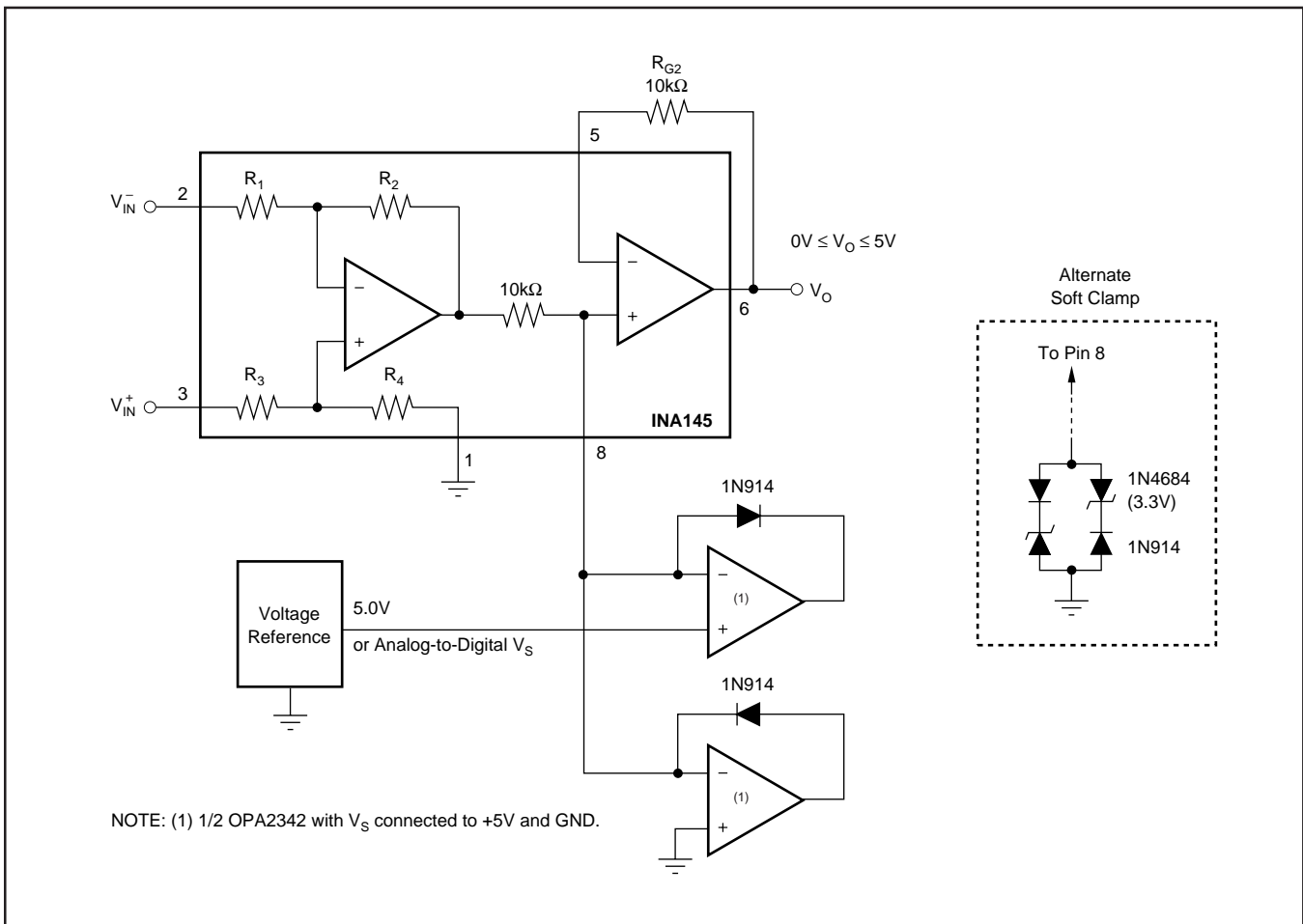

FIGURE 6. Clamp Circuits.

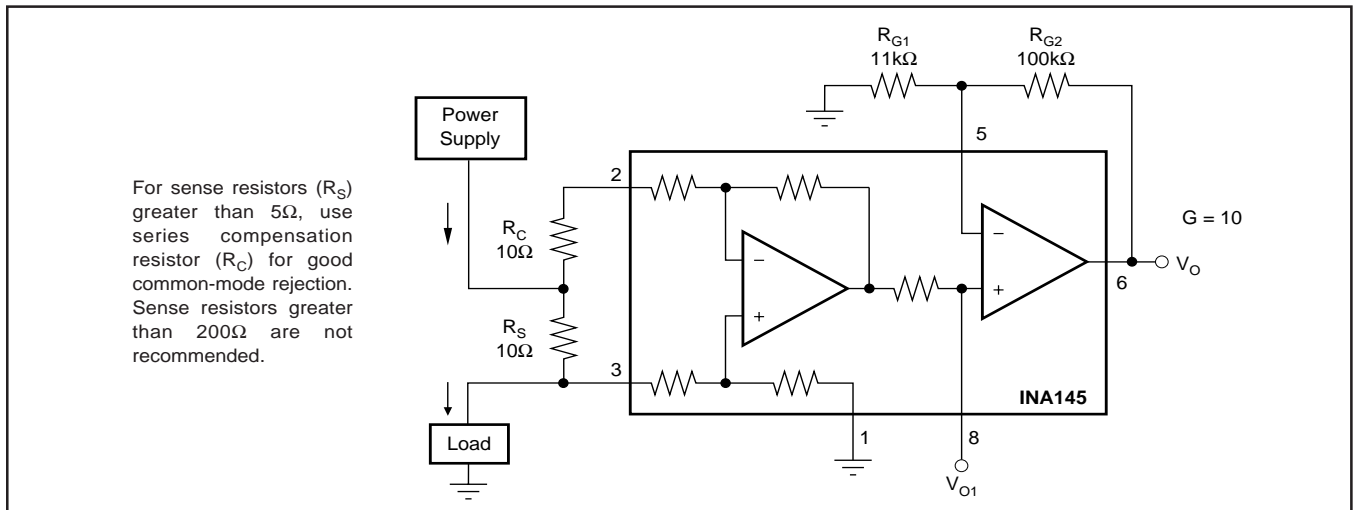

FIGURE 7. Current Monitor,  $G = 1$ .

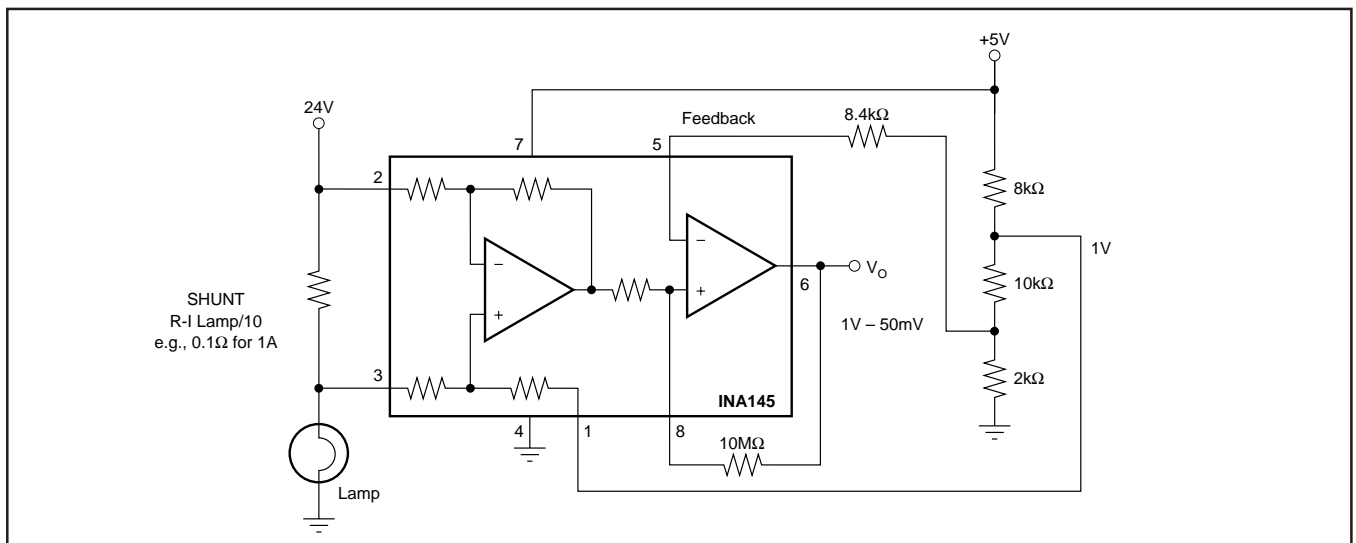

FIGURE 8. Comparator Output with Optional Hysteresis Application to Sense Lamp Burn-Out.

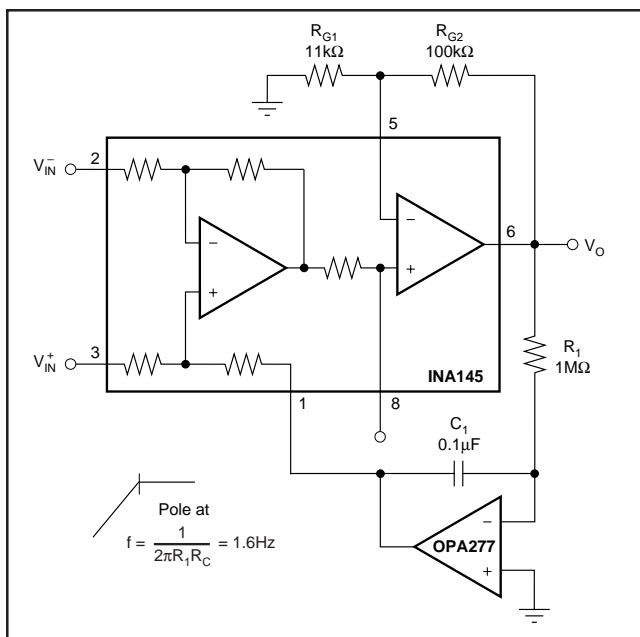

FIGURE 9. AC Coupling (DC Restoration).

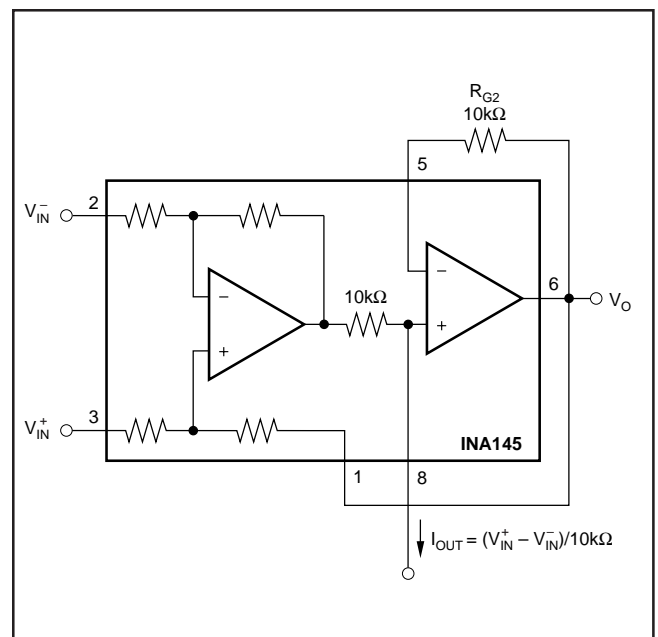

FIGURE 10. Precision Current Source.

This datasheet has been downloaded from:

[www.DatasheetCatalog.com](http://www.DatasheetCatalog.com)

Datasheets for electronic components.



LittleDiode supplies new, hard to find or obsolete electronic components and semiconductors all over the world.

With over two million different components listed you are sure to find the part you need.

Feel free to visit us today at our online store:

[LittleDiode.com](http://LittleDiode.com)

Looking forward to providing you with the best possible service.