

IPS5751/IPS5751S

FULLY PROTECTED HIGH SIDE POWER MOSFET SWITCH

Features

- Over temperature protection (with auto-restart)
- Over current shutdown
- Active clamp
- E.S.D protection
- Status feedback
- Open load detection
- Logic ground isolated from power ground

Description

The IPS5751/IPS5751S are fully protected five terminal high side switch with built in short circuit, over-temperature, ESD protection, inductive load capability and diagnostic feedback. The over-current protection latches off the device if the output current exceeds $I_{shutdown}$. It can be reset by turning the input pin low. The over-temperature protection turns off the high side switches if the junction temperature exceeds $T_{shutdown}$. It will automatically restart after the junction has cooled $7^{\circ}C$ below $T_{shutdown}$. A diagnostic pin is provided for status feedback of over-current, over-temperature and open load detection. The double level shifter circuitry allows large offsets between the logic ground and the load ground.

Product Summary

$R_{ds(on)}$	25m Ω (max)
V_{clamp}	50V
$I_{shutdown}$	35A
$I_{open\ load}$	1A

Truth Table

Op. Conditions	In	Out	Dg
Normal	H	H	H
Normal	L	L	H
Open load	H	H	L
Open load	L	X	H
Over current	H	L (latched)	L
Over current	L	L	H
Over-temperature	H	L (cycling)	L (cycling)
Over-temperature	L	L	H

Typical Connection

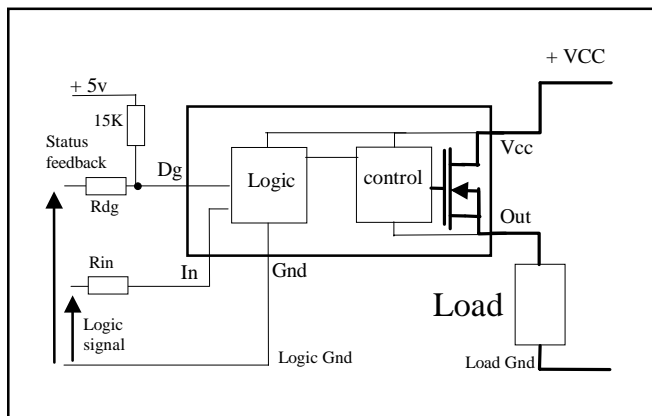

Packages

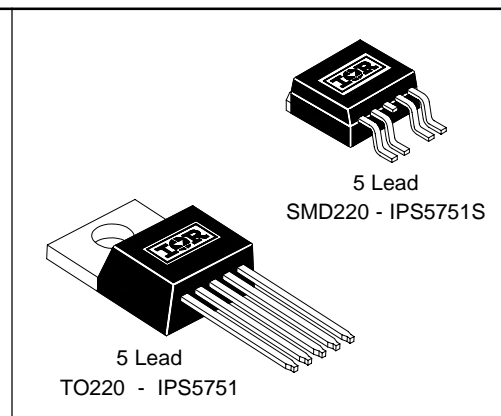

IPS5751/IPS5751S

International
IR Rectifier

Absolute Maximum Ratings

Absolute maximum ratings indicate sustained limits beyond which damage to the device may occur. All voltage parameters are referenced to GROUND lead. (T_{Ambient} = 25°C unless otherwise specified).

Symbol	Parameter	Min.	Max.	Units	Test Conditions
V _{out}	Maximum output voltage	V _{CC} -45	V _{CC} +0.3	V	
V _{offset}	Maximum logic ground to load ground offset	V _{CC} -45	V _{CC} +0.3		
V _{in}	Maximum Input voltage	-0.3	5.5		
I _{in, max}	Maximum IN current	-5	10	mA	
V _{dg}	Maximum diagnostic output voltage	-0.3	5.5	V	
I _{dg, max}	Maximum diagnostic output current	-1	10	mA	
I _{sd cont.}	Diode max. continuous current ⁽¹⁾			A	
	(R _{th} =60°C/W) IPS5751	—	2.8		
	(R _{th} =80°C/W) IPS5751S	—	2.2		
I _{sd pulsed}	Diode max. pulsed current ⁽¹⁾	—	45		
ESD1	Electrostatic discharge voltage (Human Body)	—	4	kV	C=100pF, R=1500Ω,
ESD2	Electrostatic discharge voltage (Machine Model)	—	0.5		C=200pF, R=0Ω, L=10μH
P _d	Maximum power dissipation ⁽¹⁾			W	
	(R _{th} =60°C/W) IPS5751	—	2		
	(R _{th} =80°C/W) IPS5751S	—	1.56		
T _{j max.}	Max. storage & operating junction temp.	-40	+150	°C	
T _{lead}	Lead temperature (soldering 10 seconds)	—	300		
V _{cc max.}	Maximum V _{cc} voltage	—	45		V

Thermal Characteristics

Symbol	Parameter	Min.	Typ.	Max.	Units	Test Conditions
R _{th 1}	Thermal resistance junction to case	—	2	—	°C/W	TO-220
R _{th 2}	Thermal resistance junction to ambient	—	55	—		
R _{th 1}	Thermal resistance with standard footprint	—	60	—		D ² PAK (SMD220)
R _{th 2}	Thermal resistance with 1" square footprint	—	35	—		
R _{th 3}	Thermal resistance junction to case	—	5	—		

(1) Limited by junction temperature (pulsed current limited also by internal wiring)

Recommended Operating Conditions

These values are given for a quick design. For operation outside these conditions, please consult the application notes.

Symbol	Parameter	Min.	Max.	Units
V _{CC}	Continuous V _{CC} voltage	5.5	28	V
V _{IH}	High level input voltage	4	5.5	
V _{IL 1}	Low level input voltage	-0.3	0.9	
I _{out}	Continuous output current (T _{ambient} = 85°C, T _j = 125°C, R _{th} = 60°C/W) IPS5751	—	4	A
	(T _{ambient} = 85°C, T _j = 125°C, R _{th} = 80°C/W) IPS5751S	—	3.5	
I _{out} T _c =85°C	Continuous output current (T _{Case} = 85°C, I _N = 5V, T _j = 125°C, R _{th} = 5°C/W)	—	14	
R _{in}	Recommended resistor in series with IN pin	4	6	kΩ
R _{dg}	Recommended resistor in series with DG pin	10	20	

Static Electrical Characteristics

(T_j = 25°C, V_{CC} = 14V unless otherwise specified.)

Symbol	Parameter	Min.	Typ.	Max.	Units	Test Conditions
R _{ds(on)} @T _j =25°C	ON state resistance T _j = 25°C	—	19	25	mΩ	V _{in} = 5V, I _{out} = 14A
R _{ds(on)} (V _{CC} =6V)	ON state resistance @ V _{CC} = 6V	—	22	30		V _{in} = 5V, I _{out} = 7A
R _{ds(on)} @T _j =150°C	ON state resistance T _j = 150°C	—	32	—		V _{in} = 5V, I _{out} = 14A
V _{CC oper.}	Functional operating range	5.5	—	35	V	
V _{clamp 1}	V _{CC} to OUT clamp voltage 1	45	49	—		I _d = 10mA (see Fig.1 & 2)
V _{clamp 2}	V _{CC} to OUT clamp voltage 2	—	50	60		I _d = I _{shutdown} (see Fig.1 & 2)
V _f	Body diode forward voltage	—	0.9	1.2		I _d = 14A, V _{in} = 0V
I _{out} leakage	Output leakage current	—	10	50	μA	V _{out} = 0V, T _j = 25°C
I _{CC off}	Supply current when OFF	—	10	50		V _{in} = 0V, V _{out} = 0V
I _{CC on}	Supply current when ON	—	4.5	10	mA	V _{in} = 5V
I _{CC ac}	Ripple current when ON (AC RMS)	—	20	—	μA	V _{in} = 5V
V _{dgl}	Low level diagnostic output voltage	—	0.3	0.45	V	I _{dg} = 0.3 mA
I _{dg} leakage	Diagnostic output leakage current	—	1.5	10	μA	V _{dg} = 4.5V
V _{ih}	IN high threshold voltage	—	2.7	3.4	V	
V _{il}	IN low threshold voltage	1	2.0	—		
I _{in, on}	On state IN positive current	—	30	80	μA	V _{in} = 4V
V _{CCUV+}	V _{CC} UVLO positive going threshold	—	4.7	5.5	V	
V _{CCUV-}	V _{CC} UVLO negative going threshold	3.0	4.4	—		
I _{nhyst.}	Input hysteresis	0.2	0.6	1.5		

IPS5751/IPS5751S

International
IR Rectifier

Switching Electrical Characteristics

$V_{CC} = 14V$, Resistive Load = 1Ω , $T_j = 25^\circ C$, (unless otherwise specified).

Symbol	Parameter	Min.	Typ.	Max.	Units	Test Conditions
T_{don}	Turn-on delay time	—	5	20	μs	See figure 3
T_{r1}	Rise time to $V_{out} = V_{CC} - 5V$	—	4	20		
T_{r2}	Rise time from the end of T_{r1} to $V_{out} = 90\%$ of V_{CC}	—	65	150		
dV/dt (on)	Turn ON dV/dt	—	3	6	$V/\mu s$	
E_{on}	Turn ON energy	—	2	—	mJ	See figure 4
T_{doff}	Turn-off delay time	—	65	150	μs	
T_f	Fall time to $V_{out} = 10\%$ of V_{CC}	—	8	20		
dV/dt (off)	Turn OFF dV/dt	—	5	10	$V/\mu s$	
E_{off}	Turn OFF energy	—	0.75	—	mJ	

Protection Characteristics

Symbol	Parameter	Min.	Typ.	Max.	Units	Test Conditions
T_{sd+}	Over-temp. positive going threshold	—	165	—	$^\circ C$	See fig. 2
T_{sd-}	Over-temp. negative going threshold	—	158	—	$^\circ C$	See fig. 2
I_{sd}	Over-current threshold	22	35	50	A	See fig. 2
$I_{open\ load}$	Open load detection threshold	0.3	1	2	A	
T_{reset}	Minimum time to reset protections	—	50	—	μs	$V_{in} = 0V$
T_{dg}	Blanking time before considering D_g	—	7	100	μs	Part turned on with $V_{in} = 5V$

Functional Block Diagram (All values are typical)

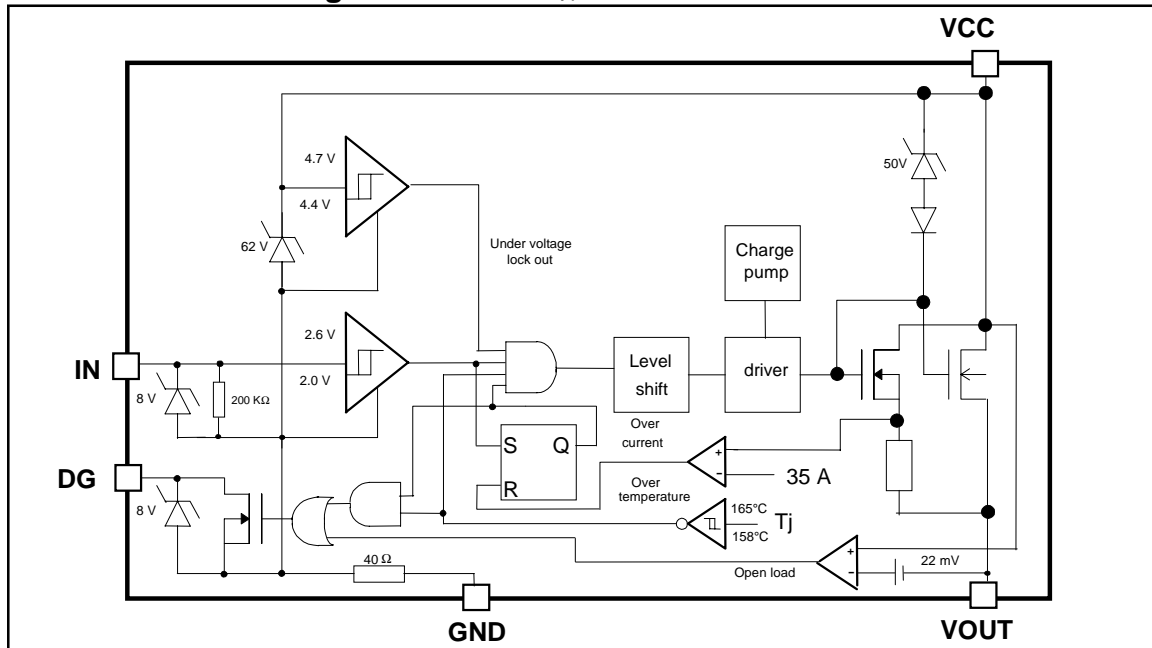

Lead Assignments

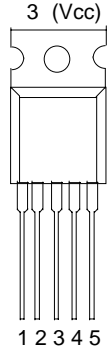
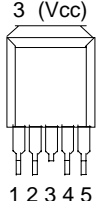
 <p>3 (Vcc)</p> <p>1 2 3 4 5</p> <p>5 Lead - TO220</p>	<p>1 - Ground 2 - In 3 - Vcc 4 - DG 5 - Out</p>	 <p>3 (Vcc)</p> <p>1 2 3 4 5</p> <p>5 Lead - D²PAK (SMD220)</p>
<p>IPS5751 (qualifications based on AEC Q 101)</p>		<p>IPS5751S (qualifications based on industrial level)</p>
<p>Part Number</p>		

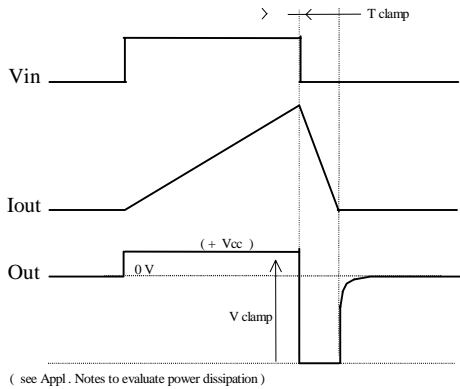

Figure 1 - Active clamp waveforms

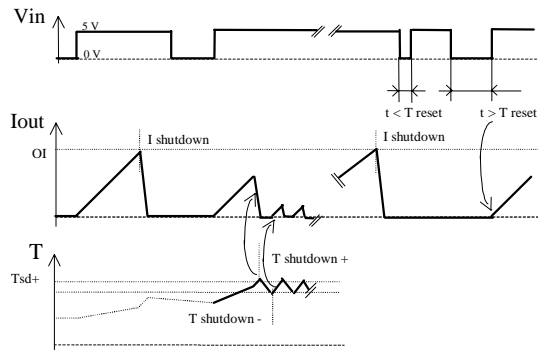

Figure 2 - Protection timing diagram

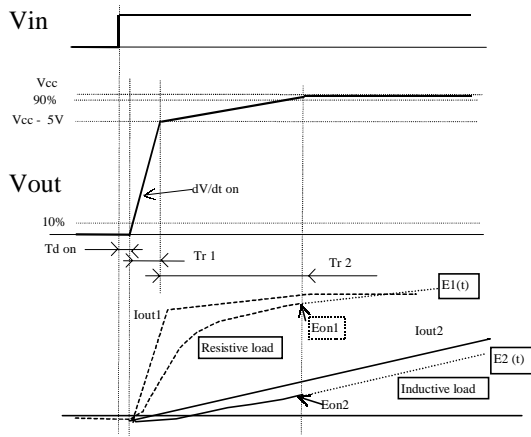

Figure 3 - Switching times definition (turn-on)
Turn on energy with a resistive or an inductive load

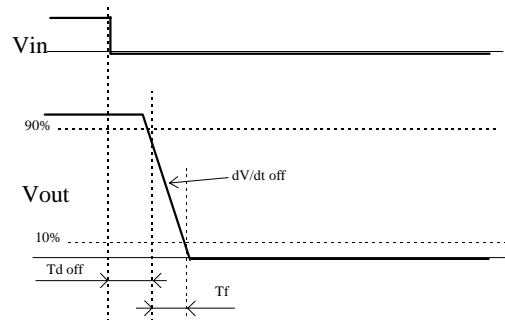

Figure 4 - Switching times definition (turn-off)

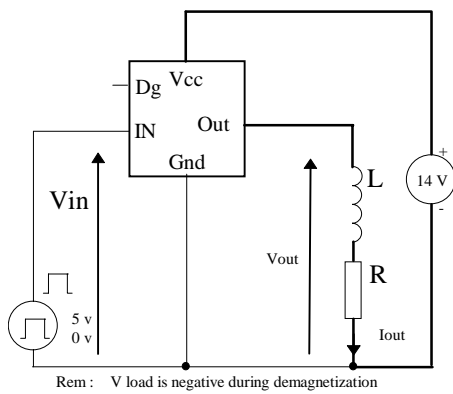

Figure 5 - Active clamp test circuit

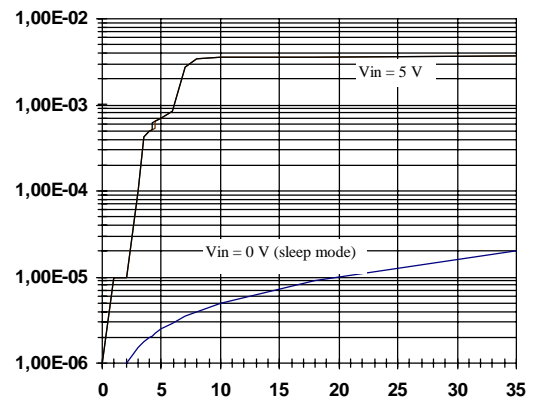

Figure 6 - I_{cc} (mA) Vs V_{cc} (V)

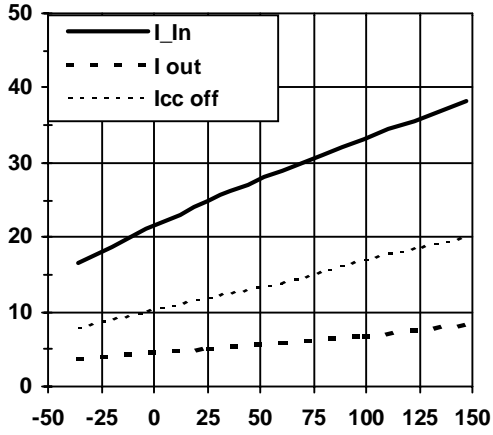

Figure 7 - I_{in} , I_{out} & $I_{cc\ off}$ (μA) Vs T_j (°C)

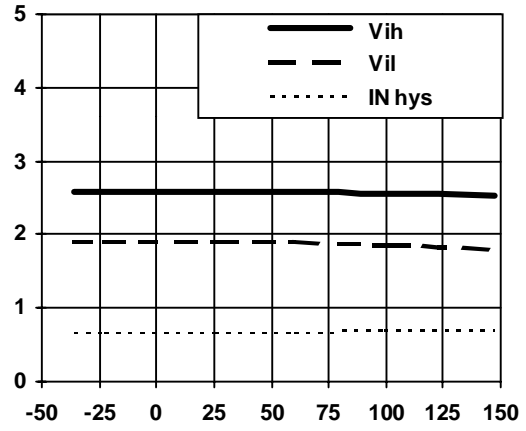

Figure 8 - V_{ih} , V_{il} & $I_N\ hyst.$ (V) Vs T_j (°C)

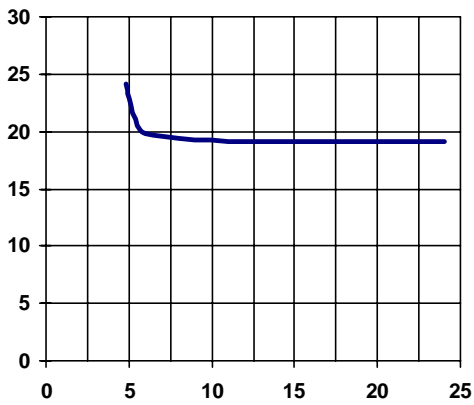

Figure 9 - R_{dson} ($m\Omega$) vs V_{cc} (V)

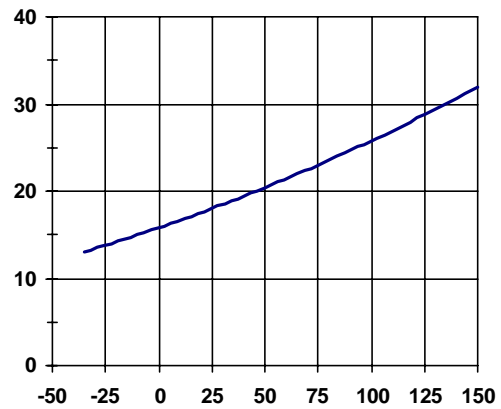

Figure 10 - R_{dson} ($m\Omega$) vs T_j (°C)

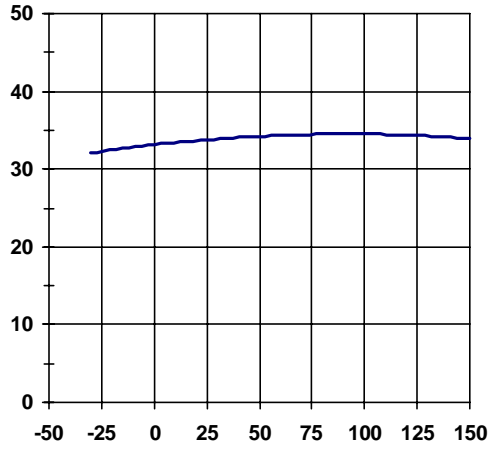

Figure 11 - I shutdown (A) vs Tj (°C)

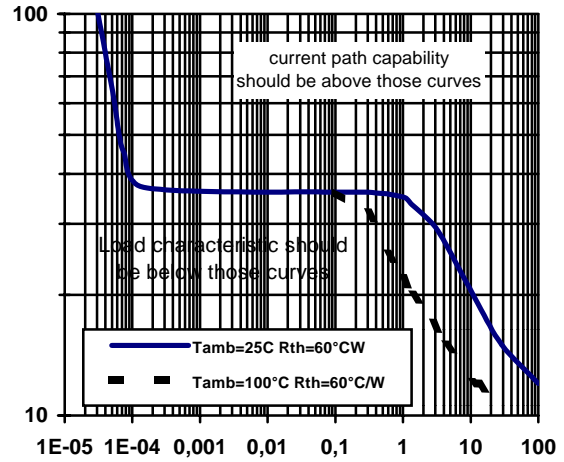

Figure 12 - Protection characteristic - (A) vs (S) *

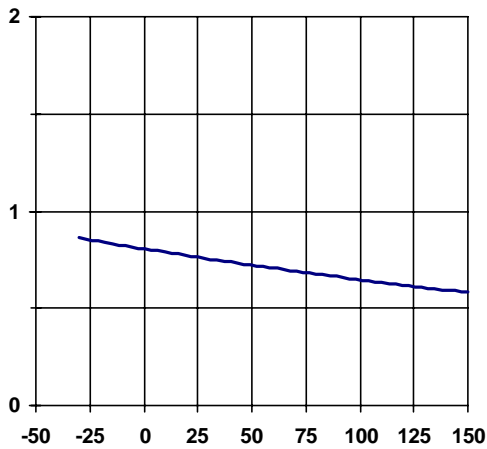

Figure 13 - I open load (A) vs Tj (°C)

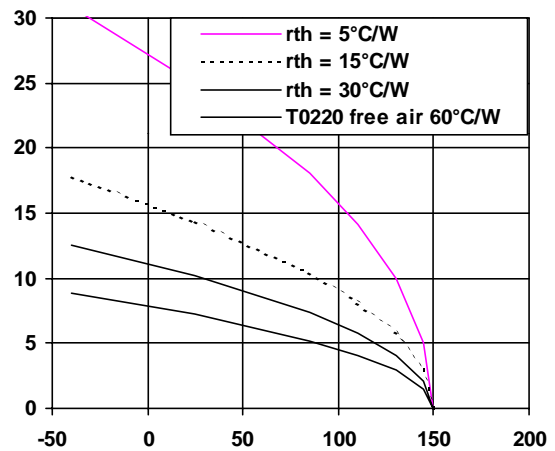

Figure 14 - Max. Cont. Ids (A) Vs Amb. Temperature (°C)

NOTE: * Over-current protection for less than 1ms and thermal protection for durations higher than 1s.

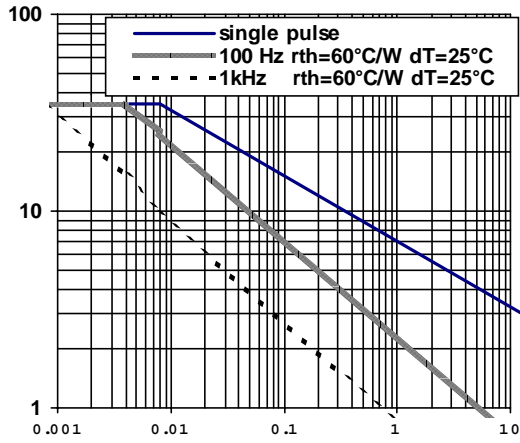

Figure 15 -Max. I clamp (A) Vs Inductive Load (m H)

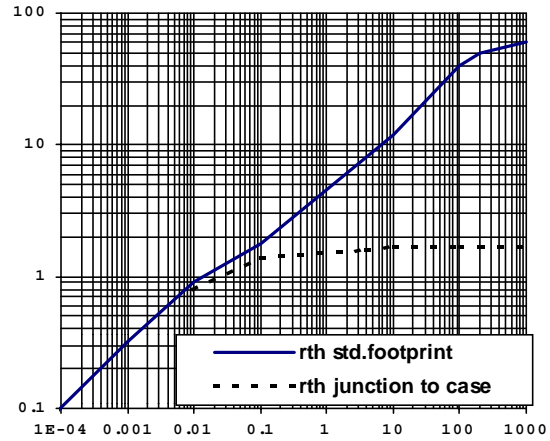

Figure 16 - Transient Rth (°C/W) Vs Time (s)

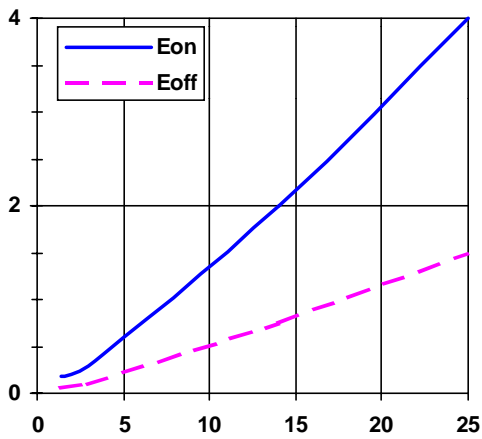

Figure 17 - Eon, Eoff @ Vcc=14V (mJ) vs Iout (A)

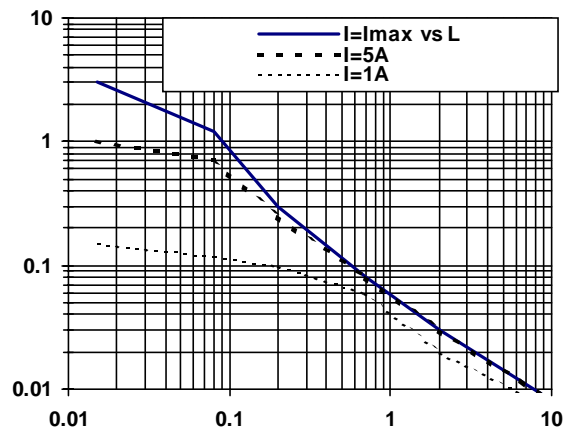
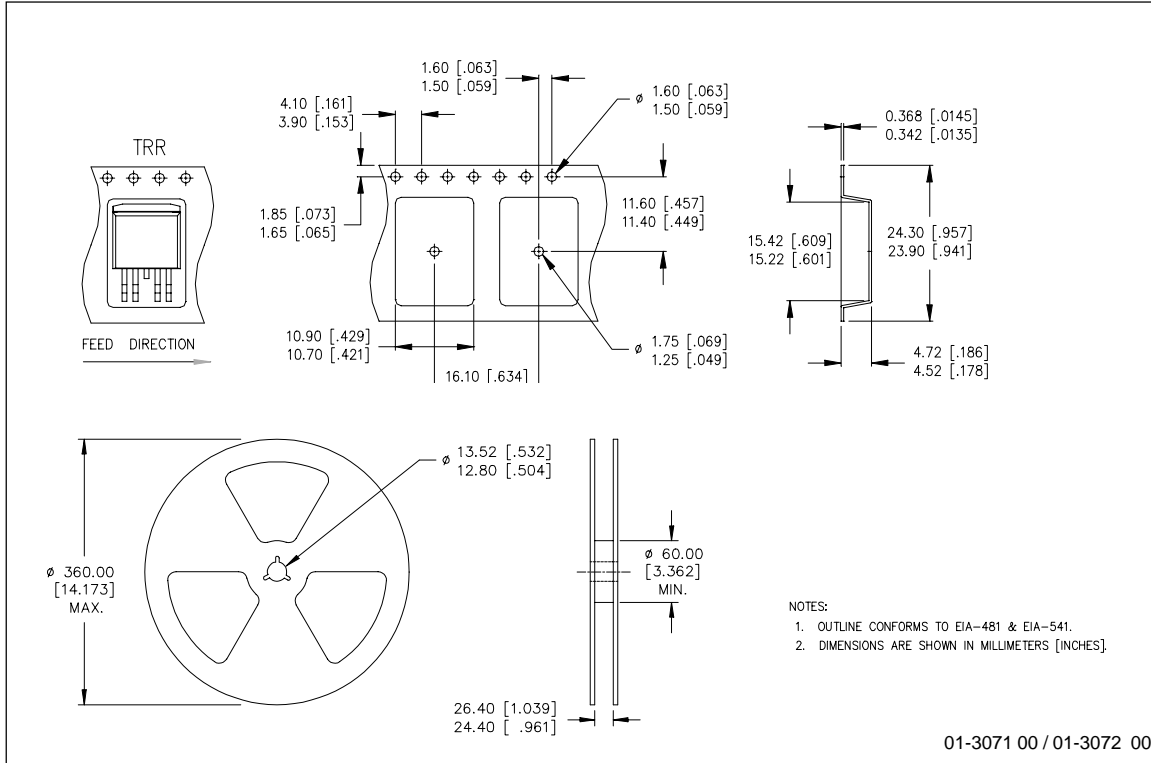

Figure 18 - Eon @ Vcc=14V (mJ) vs Inductance (mH)

IPS5751/IPS5751S

International
IR Rectifier

Tape & Reel - D²PAK (SMD220) - 5 Lead



Case Outline - TO220 (5 lead)

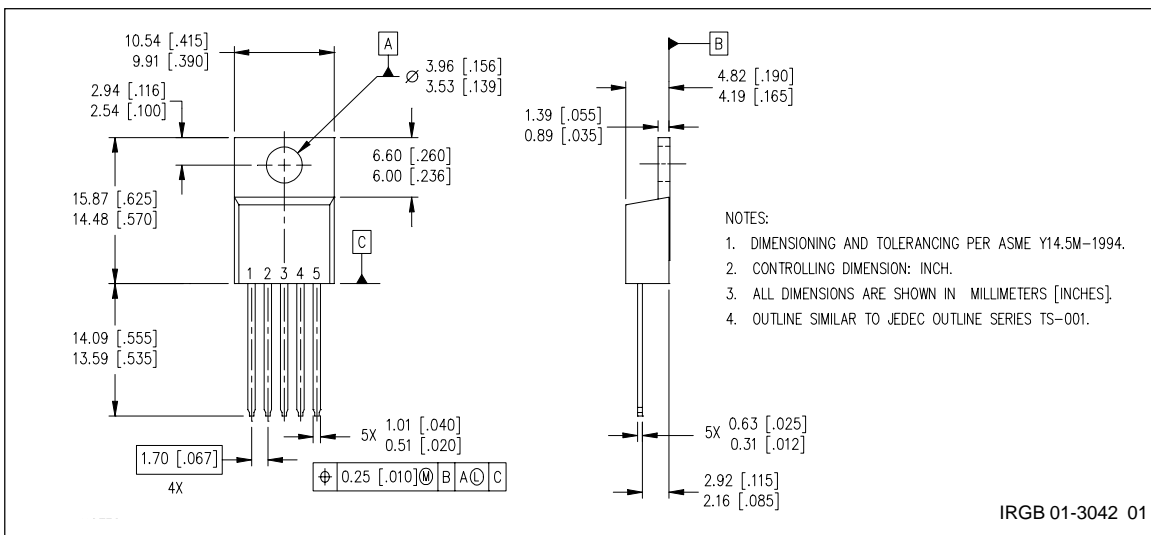

Case Outline - D²PAK (SMD220) - 5 Lead

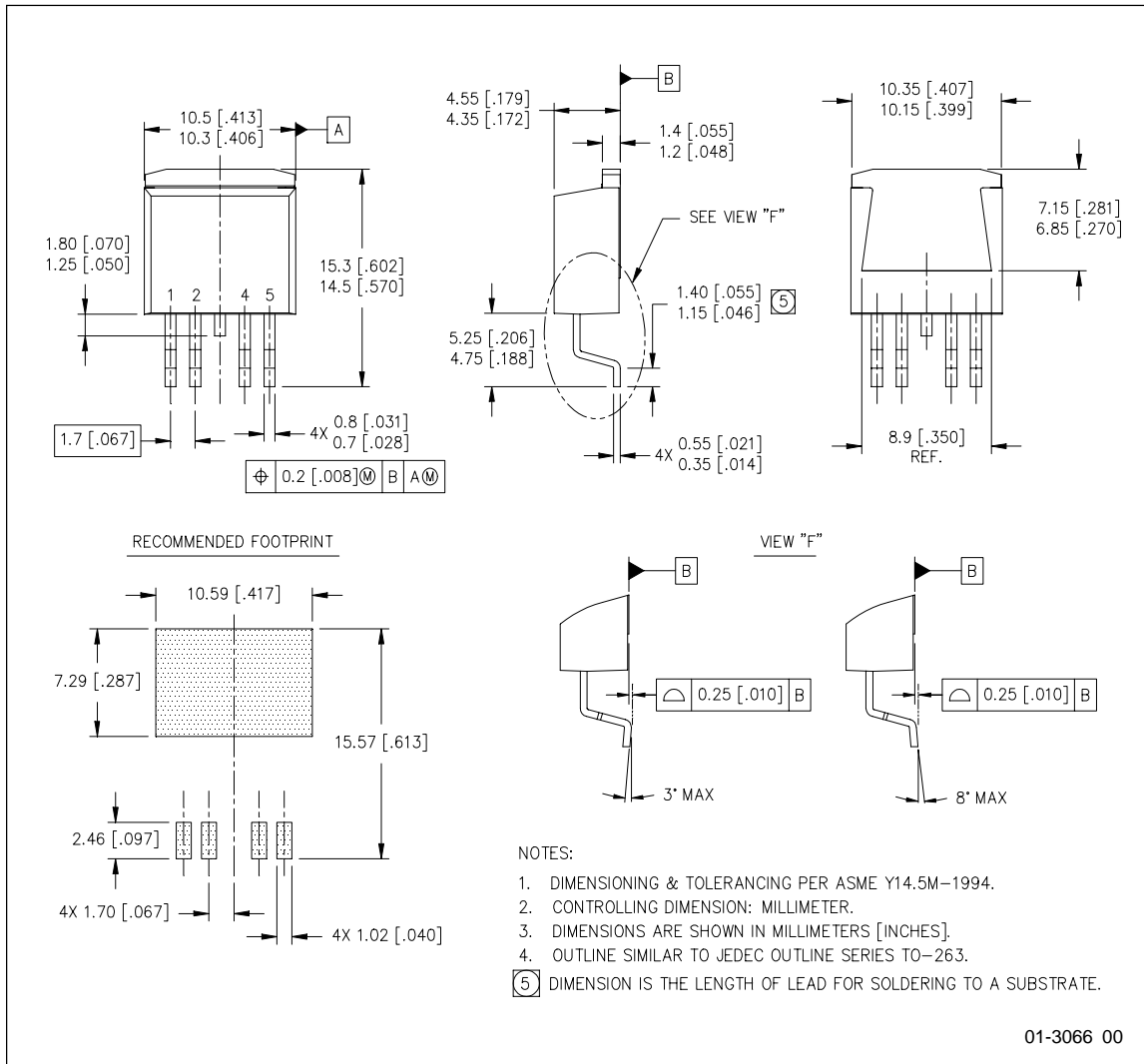



LittleDiode supplies new, hard to find or obsolete electronic components and semiconductors all over the world.

With over two million different components listed you are sure to find the part you need.

Feel free to visit us today at our online store:

LittleDiode.com

Looking forward to providing you with the best possible service.