

# IR2C24/IR2C24N 6-Unit 320mA Transistor Array

## Description

The IR2C24/IR2C24N is a 6-circuit driver IC which can be used for driving printer, relays, LEDs and lamps. The strobe pin enables all circuits to cut off without external transistors.

Clamping diodes protect output transistors from counter electromotive force.

## Features

1. With strobe pin
2. With clamping diodes
3. Output breakdown voltage  
 $BV_{CEO} = 20V(\text{MAX.})$
4. Output current  $320mA(\text{MAX.})$
5. 16-pin dual-in-line package(IR2C24)  
16-pin small-outline package(IR2C24N)

## Pin Connections

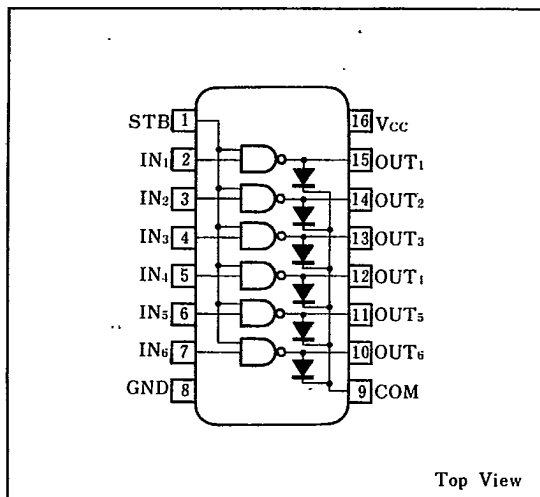

## Equivalent Circuit

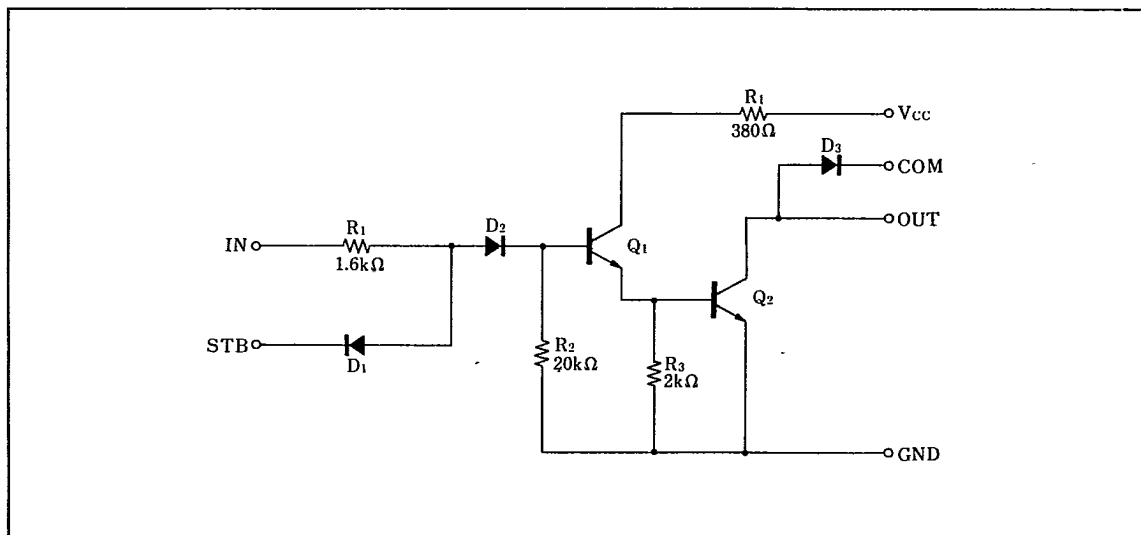

SHARP

## 6-Unit 320mA Transistor Array

IR2C24/IR2C24N

7-52-07

## ■ Absolute Maximum Ratings

Parameter	Symbol	Condition	Rating	Unit	
Supply voltage	$V_{CC}$		10	V	
Input voltage	$V_{IN}$		-25~+20	V	
Output current	$I_{OUT}$	Each circuit	320	mA	
Output breakdown voltage	$BV_{CEO}$		20	V	
Strobe input voltage	$V_{IN\ STB}$		20	V	
Clamp diode reverse voltage	$V_R$	For clamp diode	20	V	
Clamp diode surge current	$I_{surge}$	For clamp diode	320	mA	
Power dissipation	$P_D$	$T_a \leq 25^\circ C$	IR2C24	1,470	mW
			IR2C24N	600	
$P_D$ derating ratio	$\Delta P_D / ^\circ C$	$T_a > 25^\circ C$	IR2C24	14.7	mW/ $^\circ C$
			IR2C24N	6	
Operating temperature	$T_{opr}$		-20~+75	$^\circ C$	
Storage temperature	$T_{stg}$		-55~+150	$^\circ C$	

## ■ Recommend Operating Conditions

(Ta = -20~+75°C)

Parameter	Symbol	Condition	MIN.	TYP.	MAX.	Unit
Supply voltage	$V_{CC}$		3		8	V
Max. output voltage	$V_{CED}$				20	V
Output current	$I_{OUT}$	$V_{CC}=6.5V$ , at 25% duty or less			300	mA
		$V_{CC}=6.5V$ , at 65% duty or less			150	
Input "High" voltage	$V_{IH}$	$I_{OUT}=300mA$	3.2			V
Input "Low" voltage	$V_{IL}$	$I_{OUT}(\text{Leak})=50\ \mu A$			0.7	V
Strobe input "High" voltage	$V_{IH\ STB}$	For strobe pin	2.4			V
Strobe input "Low" voltage	$V_{IL\ STB}$	For strobe			0.2	V

## ■ Electrical Characteristics

(V<sub>CC</sub>=8V, T<sub>a</sub>=-20~+75°C)

Parameter	Symbol	Condition	MIN.	TYP.	MAX.	Unit
Output voltage	$V_{CEO}$	$V_{IN}=3.2V$ , $V_{IN\ STB}=0.2V$ , $I_{OUT}=100\ \mu A$			20	V
On state output voltage	$V_{OUT\ ON1}$	$V_{IN}=3V$ , $V_{IN\ STB}=2.4V$	$V_{CC}=6.5V$ , $I_{OUT}=300mA$	0.6	1.0	V
			$V_{CC}=6.5V$ , $I_{OUT}=250mA$	0.5	0.85	
	$V_{OUT\ ON2}$	$V_{CC}=3V$ , $I_{OUT}=120mA$	0.3	0.5		
Input current	$I_{IN}$	$V_{IN}=3.2V$ , $V_{IN\ STB}=2.4V$			1.4	mA
Input reverse leakage current	$I_{IR}$	$V_{IN}=-25V$			-20	$\mu A$
Strobe input current	$I_{IN\ STB}$	For strobe pin, $V_{IN}=3.2V(\text{All input})$ , $V_{IN\ STB}=0.2V$		-7.9		mA
Strobe input reverse leakage current	$I_{IR\ STB}$	For strobe pin, $V_{IN}=0V$ , $V_{IN\ STB}=20V$			20	$\mu A$
Clamp diode forward voltage	$V_F$	For clamp diode, $I_{surge}=320mA$		1.4	2.4	V
Clamp diode reverse voltage	$V_R$	For clamp diode, $I_R=100\ \mu A$	20	40		V
Supply current	$I_{CC}$	$V_{IN}=3.2V(\text{All input})$ , $V_{IN\ STB}=2.4V$			200	mA
DC current amplitude	$h_{FE}$	$V_{CC}=6.5V$ , $V_{CEO}=4V$ , $I_{OUT}=300mA$ , $T_a=25^\circ C$	1,000			

SHARP



LittleDiode supplies new, hard to find or obsolete electronic components and semiconductors all over the world.

With over two million different components listed you are sure to find the part you need.

Feel free to visit us today at our online store:

[LittleDiode.com](http://LittleDiode.com)

Looking forward to providing you with the best possible service.